

**MUNICIPALITY OF ANCHORAGE
STANDARD SPECIFICATIONS
2023 DRAFT**

**DIVISION 75
LANDSCAPING IMPROVEMENTS**

DRAFT

**STANDARD CONSTRUCTION SPECIFICATIONS
LANDSCAPING IMPROVEMENTS
DIVISION 75
INDEX**

SECTION 75.01	GENERAL	1
Article 1.1	Scope of Work.....	1
Article 1.2	Glossary of Terms.....	1
Article 1.3	Payment - General	1
SECTION 75.02	LANDSCAPING	2
Article 2.1	General	2
Article 2.2	Materials	2
Article 2.3	Construction.....	7
Article 2.4	Maintenance.....	12
Article 2.5	Landscaping Acceptance	15
Article 2.6	Measurement	15
Article 2.7	Basis of Payment	16
SECTION 75.03	PLANTING SOILS.....	17
Article 3.1	General	17
Article 3.2	Materials	17
Article 3.3	Placing	18
Article 3.4	Measurement	19
Article 3.5	Basis of Payment	19
SECTION 75.04	SEEDING	20
Article 4.1	General	20
Article 4.2	Materials	20
Article 4.3	Application.....	23
Article 4.4	Maintenance.....	26
Article 4.5	Seeding Acceptance	26
Article 4.6	Measurement	27
Article 4.7	Basis of Payment	28
SECTION 75.05	SOD	29
Article 5.1	General	29
Article 5.2	Materials	29
Article 5.3	Construction	29
Article 5.4	Maintenance.....	31
Article 5.5	Measurement	31
Article 5.6	Basis of Payment	31

SECTION 75.06	LANDSCAPE EDGING	32
Article 6.1	General	32
Article 6.2	Materials	32
Article 6.3	Construction	32
Article 6.4	Measurement	32
Article 6.5	Basis of Payment	32
SECTION 75.07	LANDSCAPE FABRIC	33
Article 7.1	General	33
Article 7.2	Materials	33
Article 7.3	Construction	33
Article 7.4	Measurement	33
SECTION 75.08	WILLOW STAKING	34
Article 8.1	General	34
Article 8.2	Materials	34
Article 8.3	Construction	34
Article 8.4	Maintenance.....	35
Article 8.5	Willow Staking Acceptance	36
Article 8.6	Measurement	37
Article 8.7	Basis of Payment	37
SECTION 75.09	SITE FURNISHINGS	38
Article 9.1	General	38
Article 9.2	Materials	38
Article 9.3	Construction	38
Article 9.4	Method of Measurement	38
Article 9.5	Basis of Payment	39
SECTION 75.10	BOLLARDS	48
Article 10.1	General	48
Article 10.2	Materials	48
Article 10.3	Construction	50
Article 10.4	Method of Measurement	50
Article 10.5	Basis of Payment	51
SECTION 75.11	MODULAR CONCRETE BLOCK WALL	52
Article 11.1	Description	52
Article 11.2	Materials	52
Article 11.3	Manufacturer and Local Representative	52
Article 11.4	Construction	52
Article 11.5	Method of Measurement	52
Article 11.6	Basis of Payment	53
SECTION 75.12	BOULDERS	54
Article 12.1	General	54
Article 12.2	Materials	54
Article 12.3	Construction	54
Article 12.4	Method of Measurement	54

Article 12.5	Basis of Payment	54
SECTION 75.13	ROOT PRUNING	55
Article 13.1	General	55
Article 13.2	Materials	55
Article 13.3	Quality Assurance	55
Article 13.4	Construction	55
Article 13.5	Measurement	56
Article 13.6	Basis of Payment	56
SECTION 75.14	TREE PROTECTION FENCE	57
Article 14.1	General	57
Article 14.2	Submittals	57
Article 14.3	Quality Assurance	57
Article 14.4	Materials	58
Article 14.5	Construction	58
Article 14.6	Measurement	58
Article 14.5	Basis of Payment	58
SECTION 75.15	MOOSE PROTECTON FENCE	59
Article 15.1	General	59
Article 15.2	Materials	59
Article 15.3	Construction	59
Article 15.4	Method of Measurement	59
Article 15.5	Basis of Payment	59
SECTION 75.16	RESET FENCE	60
Article 16.1	General	60
Article 16.2	Materials	60
Article 16.3	Construction	60
Article 16.4	Measurement	60
Article 16.5	Basis of Payment	60
SECTION 75.17	CHAIN LINK FENCE	61
Article 17.1	General	61
Article 17.2	Materials	61
Article 17.3	Tables	63
Article 17.4	Construction	64
Article 17.5	Measurement	66
Article 17.6	Basis of Payment	66

**STANDARD CONSTRUCTION SPECIFICATIONS FOR
LANDSCAPING IMPROVEMENTS
DIVISION 75**

SECTION 75.01 GENERAL

Article 1.1 Scope of Work

The Work covered by these Specifications consists of providing all plants, labor, equipment, supplies, material, transportation, handling and storage, and performing all operations in connection with the construction of the landscaping improvements as provided for in this Division.

Article 1.3 Payment - General

Payment for all Work (including the Plant Establishment Period) included in this Division shall be paid for in accordance with the Division 10, Section 10.07 - Measurement and Payment, and shall include full payment for all Work described.

DRAFT

SECTION 75.02 LANDSCAPING

Article 2.1 General

A. Scope of Work

The work under this Section consists of providing all operations pertaining to the planting and maintenance of trees, shrubs, ground cover, perennials and annuals. The Work shall also include all operations pertaining to removing and replacing trees and protecting new and existing trees in place.

B. Applicable Standards:

All operations shall meet industry consensus on the planting and care operations and all plant materials used shall be true to name and size in conformity with the following standards:

1. *American Standard for Nursery Stock*, ANSI Z60.1 American Nursery and Landscape Association, Washington, D.C., latest edition.
2. *New Sunset New Western Garden Book*, Lane Publishing Company, Menlo Park, California, latest edition.
3. *Landscape Plants for Alaska*, www.alaskaplants.org.
4. *ANSI Standard A300 – American National Standards for Tree Care Operations – Tree, Shrub, and Other Woody Plant Maintenance – Standard Practices*. American National Standards Institute, New York, New York, latest edition.
5. *ANSI Standard Z133 – Safety Requirements for Arboricultural Operations*, American National Standard for Tree Care Operations. American National Standards Institute, New York, New York.
6. *Manual of Woody Landscape Plants*, Michael A. Dirr, Stipes Publishing, LLC, latest edition, Champaign, Illinois.

C. Definition

Planting Areas: The term "planting areas" or "planted and seeded areas" as used in this Specification, shall mean all areas to be planted with trees, shrubs, native plant materials, , perennials, bulbs, , annuals, willow staking, ground cover, sod, and/or seeded areas.

D. Submittals

Submittals for this section include, but are not limited to, the following:

1. Plant sourcing report
2. Two pounds of proposed mulch
3. Maintenance Schedule
4. Watering Schedule
5. Water Bag Product Data
6. Soil testing results

7. Proof of fertilizer safety and acceptability by State, Federal and Local jurisdictions
8. Proof of certification for fertilizer application
9. Mowing Schedule

Article 2.2 Materials

A. Plant Materials

1. Plant Schedule

A complete schedule of plants, including names, quantities, sizes, and other requirements, is shown on the Landscape Drawings. The Contractor shall furnish a report listing the proposed sources of the plants and location grown. In the event of plant count discrepancy between the Plant Schedule and the plants counted on the Drawings, the Drawings shall prevail. Discrepancies between the quantity shown on the Plant Schedule and those required by the Drawing shall not entitle the Contractor to claim any additional compensation, nor relieve them of the obligation to complete the Work shown on the Drawings.

No substitutes shall be accepted, except with the written permission of the Engineer. The Contractor shall submit all substitution requests, noting the source of plants, location, size, and condition, within thirty (30) days of receiving the Notice to Proceed. Substitutes shall be inspected by the Engineer prior to installation.

Each plant shall have a durable, legible label with plant size and name (genus, species, variety, cultivar) securely attached when delivered and it shall remain in place until after acceptance. Labels shall not girdle or damage plants. Contractor shall remove label from plant material at time of acceptance.

2. Plant Quality

a. Species and Culture

All plants shall be true to species and variety specified, and in accordance with the American Standard for Nursery Stock and good horticultural practices.

Plants shall be so trained in development and appearance as to be compact and symmetrical. They shall be sound, healthy, vigorous, well-branched, and densely foliated when in leaf. Plants shall be free of disease and insect adults, eggs, pupa, or larvae. They shall have healthy, well developed root systems, and shall be free from physical damage or other conditions that would prevent growth.

All plant material shall be free of contamination by any plant not specified, including non-native invasive plants, seeds, and plant parts.

b. Tree Trunk Specifications

Tree trunks shall be straight and well-tapered. Trees with multiple leaders, unless specified, will be rejected. Damaged, cut, or crooked leaders; included bark, bark abrasions, sunscald, disfiguring knots, mold, and prematurely opened buds, or cut limbs over three-quarter inch (3/4") diameter that are not completely callused are cause for rejection.

Trunk diameter and taper shall be sufficient so that tree remains vertical without support.

c. Crown Configuration Specification

Crown ratio (distance from bottom of canopy to tree top/tree height) should be at least sixty-six percent (66%) of total tree height.

One-half (1/2) or more of the foliage should be on branches originating on the lower two-thirds (2/3) of the trunk, and one-half (1/2) or less should originate on the upper one third (1/3).

Where formal arrangements of consecutive order of trees are shown, select stock for uniform height, structure, and spread.

d. Branch Specifications

All branches shall be less than two thirds (2/3) the diameter of the trunk measured one inch (1") above the branch.

The attachment of branches shall contain no bark inclusions.

There shall be one dominant leader straight to the top of the tree. Larger branches shall be spaced at least six inches (6") apart and arranged radially and vertically along the stem.

There shall be live buds or foliage to the ends of all twigs.

All pruning cuts shall comply with ANSI A300 Standards and shall be made outside the branch collar and branch bark ridge. Branches shall not be pruned immediately prior to delivery. Coniferous plants shall not have been sheared.

e. Root Flare and Root Ball Specifications

No root in the root ball larger than one-quarter inch (1/4") diameter shall circle more than one-third around the root ball. There shall be no roots in the root ball that make an abrupt turn of ninety degrees (90°) or more. There shall be no roots in the root ball that are 'J' roots, kinked, stem girdling, or potentially stem girdling. For all plants, including bare root, roots shall exhibit healthy, well-branched root systems characteristic of the species with adequate spread.

Roots in ball-in-burlap root balls or in containers shall be well-rooted and uniform throughout soil mix or growth media. Roots shall not be pot bound.

Major roots shall be less than two inches (2") from the top of root flare. The root flare (trunk flare, root collar) shall be at the surface of the root

ball (container media). As defined by ANSI Z60.1, root ball depth measurement is from the top of the ball, which in all cases shall begin at the root flare. Soil above the root flare shall not be included in ball depth measurement and should be removed.

Root ball size shall meet ANSI Z60.1.

Nursery Stock root balls shall be of sufficient depth to include absorbing roots. Balls shall be securely wrapped in burlap and tightly bound with rope or twine. Trees may be wire baskets lined with burlap and tightly bound with rope or twine. Balled-in-burlap plants with manufactured balls or container plants that are dry, cracked, or broken before the plant operation will be rejected.

The Engineer reserves the right to inspect root system of trees and shrubs and to reject any material found to be non-compliant.

3. Size and Grading Standards

Plants shall have a standard balance between height, crown spread, diameter and root ball size according to the ANSI Z60.1. All plants shall be typical of their species or variety.

Plants shall conform to the measurements specified except that plants larger than those specified may be used, if approved by the Engineer. If larger plants are approved, the root ball, root spread, or container shall be increased in proportion of the size of the plant.

Caliper measurements shall be taken six inches (6") above the trunk flare for trees up to four inches (4") in caliper, and 12 inches (12") above the trunk flare for trees over four inches (4") in caliper. Plants shall be measured when branches are in their normal position. If a range of size is given, no plant shall be less than the minimum size, and no less than fifty percent (50%) of the plants shall be as large as the maximum size specified. Plants that meet measurements but do not possess a normal balance between height and spread shall be rejected.

Plants shall not be altered by pruning or other means to meet specifications.

4. Plant Certification

All plants shall comply with State and Federal laws governing the shipping, selling and handling of plant stock and inspection for plant diseases and pest infestations. Plants shall be certified free from disease and infestation and invasive weeds. Any inspection certificates required by law shall accompany each shipment invoiced or order of stock, and on arrival, the certificate shall be filed with the Engineer before acceptance.

5. Delivery, Storage, and Handling

All plants shall be packed, transported, and handled with utmost care to ensure adequate protection against injury or damage to the root ball, and desiccation. Plants must be protected from excessive vibrations. Plants shall not be thrown or bounced off a truck or loader to the ground. Plants shall not

be dragged, lifted, or pulled by the trunk or branches in a manner that will damage the branches or loosen the roots in the ball.

Plants material transported in vehicles shall be protected from wind whipping either by use of covered vehicle or secure tarps. Failure to protect plant material during transport to the site will result in rejection of plant material.

6. Inspection

The Engineer shall make periodic inspections prior to and during the installation and maintenance periods of the Work. All plants shall be inspected upon delivery to the job site whereupon the Engineer has the right to reject unacceptable plant material. Should plant materials, installation procedures, or other conditions be observed not in keeping with the Drawings, details, and these Specifications, the Engineer will direct the

Contractor to correct by repair, and/or replacement as appropriate. The Engineer shall be the sole judge of the conditions of quality and acceptability and will direct all corrections in writing to the Contractor. All rejected materials shall be immediately removed from the site and replaced with specified materials at no additional cost to the Owner.

B. Mulch

Mulch shall consist of shredded bark mulch, wood chips or rock mulch as specified on the Drawings. Material shall be uniform in size, color, quality and overall appearance. Mulch shall be free of material injurious to plant growth. Sources of mulch should be free of weeds and invasive plant parts or seeds. Sawdust, dirt, garbage, or other debris mixed in the mulch is not acceptable. Contractor shall submit two pounds of proposed mulch for inspection by Engineer.

1. Wood Chips

Wood chips shall consist of wood products having a size of two and one-half inch (2-1/2") minus with a thickness not greater than three-eighths inch (3/8"). Wood chips shall be uniform in overall appearance, color, quality, and size and are subject to approval by the Engineer. Wood chips are to be free of sawdust, dirt, twigs, excessive bark, or any other debris.

2. Shredded Bark Mulch

Shredded bark mulch shall consist of shredded bark and wood. The size range of fine particles shall be 3/8 inch or less and a maximum size of individual pieces shall be approximately 1 to 1-1/2 inch in diameter and maximum length of approximately 4 to 8 inches. No more than 25% of the total volume shall be fine particles and no more than 20% of total volume be large pieces. Mulch shall be free of invasive weeds, seeds, or propagules. The bark mulch shall have the characteristics of retaining moisture, forming a mat not susceptible to spreading by wind or rain, and providing a good growth medium for plants. Shredded bark mulch may contain up to fifty percent (50%) shredded wood material. Wood chips are not acceptable. Bark mulch containing shredded wood shall be aged a minimum of one year prior to

installation. Bark mulch shall be free of soil, rocks, and weeds.

3. Rock Mulch

Rock mulch shall be three to four inch (3" to 4") washed river rock, uniform in size. All fines shall be screened from the aggregate within a one-quarter inch (1/4") tolerance. Rock mulch shall be composed of round rocks that may be varied in color. The material shall be free of organic and inorganic debris and trash.

C. Anti-desiccants

Anti-desiccants shall consist of "Wilt-Pruf" or equal approved by the Engineer prior to procurement.

D. Planting soil

Refer to Section 75.03, Article 3.2 - Materials.

E. Chemical or Biological Additives

Refer to Section 75.03, Article 3.2, Sub Articles B - –Soil Amendments.

F. Water

Water used for the planting, establishment, and all operations of maintenance shall be potable. The water shall be suitable for irrigation, free from substances harmful to plants. The Contractor shall supply a water source unless waived by written authorization from the Engineer.

G. Wood Stakes and Ties

Staking shall be used only at the direction of the Engineer. Staking and removal of stakes shall be provided at no additional cost to the Owner.

Deciduous Trees: Contractor shall provide minimum two (2) stakes that are six feet (6') in length and are two by two inches (2" x 2") around. Stakes shall be pointed at one end.

Coniferous Trees: Contractor shall provide minimum three (3) stakes that are twenty-four inches (24") in length and are two by two inches (2" x 2") around. Stakes shall be pointed at one end.

Ties: Ties shall be of three-quarter inch (3/4") or wider bands of polypropylene, elasticized or webbed strapping, or horticultural tape. Ties shall have a smooth surface and be flexible to allow some movement of the trunk without damaging the bark.

Article 2.3 Construction

A. Notification

Contractor shall notify Engineer at least 5 (five) working days prior to delivery of plant material to the site. Engineer shall inspect plant material prior to off-loading.

B. Planting Season

Planting shall be done when temperatures are above freezing, the ground is frost free, and the soil is in a workable condition. Unless otherwise specified in writing

by the Engineer, planting of trees shall be done between May 1 and October 1.

C. Layout and Coordination

The Contractor shall mark all planting areas with stakes or paint. The Engineer shall approve the layout before planting begins. Contractor shall not stage planting operations on trails or sidewalks.

The Contractor shall obtain a utility locate and ensure that utility marking is complete before any excavation begins. The Contractor shall locate any subsurface improvements such as sprinkling system or conduits. The Contractor shall be responsible for all damage resulting from neglect or failure to comply with this requirement.

Shrubs and small trees with mature height less than fifteen feet (15') shall be planted at least ten feet (10') from overhead power lines. Trees with a mature height greater than fifteen feet (15') but less than twenty-five (25') shall be planted at least fifteen feet (15') from overhead power lines. Trees with a mature height greater than twenty-five feet (25') shall be planted at least twenty feet (20') from overhead power lines.

The Contractor shall be responsible for moving trees if planted closer than the specified distance. The Engineer reserves the right to relocate plant materials based on utility locations.

D. Protection of Existing Trees

Contractor shall protect existing trees that are not designated for removal on the Drawings. Contractor shall identify a Tree Protection Zone (TPZ), in which activities are restricted, around each existing tree that is not designated for removal on the Drawings. The TPZ shall be submitted and approved by the Engineer. The TPZ shall measure as one foot of root area per one inch Diameter Breast Height (DBH), or as noted on the drawings. The TPZ shall be defined with fencing materials that prohibit disturbance, excavation, trenching material storage, including soil or grade changes. Refer to Section 75.14 for Tree Protection Zone Fencing. The tree shall be protected to the TPZ. The Contractor shall not stage or store materials within the TPZ. Contractor shall ensure that all land disturbance, excavation, trenching and grade changes, directional boring, routing of utilities and irrigation systems, sidewalks, driveways, construction access roads, changes to street lighting, fire hydrants and utility boxes takes place outside of the TPZ. Do not permit vehicle or foot traffic within the TPZ and prevent all compaction over root systems.

Protect tree root systems from damage caused by runoff or spillage of noxious materials while mixing, placing, or storing construction materials. Protect root systems from ponding, eroding, or excessive wetting caused by dewatering operations. Contractor shall thoroughly water exposed root systems and cover them with a waterproof sheet until backfilled. Contractor shall ensure bark, branches, roots, and balls of plants are adequately protected at all times from damage, including sun, drying winds, and frost.

Contractor shall ensure tree branches, trunk, and roots of existing trees are protected during construction. Measures for protection may include effective

barrier fencing, branch and/or root pruning, protective mulch, supplementary water, soil aeration and information signage. When a tree is damaged by the Contractor, but is deemed salvageable by the Engineer, the Contractor shall prune existing branches and roots in compliance with Section 75.13 Root Pruning and with the American National Standard (ANSI) A300, Part 1, *Standard Practices Pruning* and ANSI Z133.1, *Arboricultural Operations Safety*. No pruning paint or wound dressing shall be used.

Contractor shall replace trees damaged beyond repair with trees of equivalent value based on the *Guide for Plant Appraisal* (latest edition) as appraised by a qualified International Society of Arboriculture Certified Arborist, at no additional cost to the Owner. Contractor shall remove and dispose of damaged trees and shall install replacement trees in accordance with this Section. Payment for this Work is incidental to the Contract.

E. Existing Plant Relocation:

Existing trees and shrubs designated for relocation as shown on the Drawings shall be dug according to the applicable standards for the plant type. Plants shall be dug, balled and burlapped, containerized, or dug bare root, moved and planted in accordance with specified tree planting requirements.

Trees designated for relocation may be stored in a designated plant storage area for heeling-in of materials until final planting areas are prepared. Contractor shall maintain plants in storage areas by bracing plants in vertical position and setting balls in an enclosed berm of topsoil or bark. Contractor shall water as required to maintain adequate root moisture. Contractor shall re-burlap plants balls if required before final transplanting operations.

F. Setting and Planting

Contractor shall set balled and burlapped plants, which are not planted immediately upon delivery, on the ground and protect them with soil, moist shredded bark, mulch or other acceptable material. Contractor shall protect plants, if possible, from direct sun until they are planted. Contractor shall keep the soil in the containers and root balls in a moist condition.

Width of top of planting pit will be a minimum of three (3) times the diameter of the root ball at the surface sloping to two (2) times the diameter of the root ball at the depth of the root ball. The sides of the hole will be sloped at forty-five degrees (45°) and scarified. The depth of the planting pit will vary but shall match root ball depth.

Plants shall be gently removed from containers before planting.

Each plant shall be planted straight and plumb per standard planting details. Trees shall be planted so that the root flare is at the soil surface of the ultimate finished grade. Plants planted lower than the surrounding grade will be replanted to specified grade before final inspection/approval is granted.

Plants shall be set on firm soil (undisturbed or compacted) so that plant will be at the same depth one year after planting. Any repositioning of trees shall be done by supporting and moving the root ball, not lifting by the trunk. Plants shall be set with

the top of the root flare at or slightly above finished grade. Any soil above the root flare must be carefully removed. The root flare shall be at the soil surface. At least two roots must emerge from the trunk within one to three inches (1" to 3") of the soil surface, measured four inches from the trunk.

Roots that are circling the bottom, sides or surface of the root ball shall be gently separated and directed away from the trunk. Roots of bare root plants shall be spread into a natural position, over a pedestal of firm soil if necessary, free of bunching, kinking or circling. Soil shall be worked firmly into and around the roots so that there are no air pockets. All broken or damaged roots shall be cut back to the point where they are clean and free of rot. No other root pruning shall be done.

After the plant has been set, all ropes, wire, stakes, burlap, plant labels and wrapping around the trunk or branches shall be removed.

Contractor shall remove wire baskets and burlap from the planting area. If a pulp nursery pot is used, it shall be removed from the planting area.

Staking is not recommended as a routine practice. Exceptions include very windy sites, areas where vandalism is expected, or when planting large bare root trees in light soil. Roots must remain stationary but the trunk shall be able to sway in the wind to develop trunk taper and strength. The Contractor shall remove staking and guying material no later than one (1) year after installation.

G. Backfilling Planting Pits and Planting Beds

Backfill shall be from existing soil excavated from planting pits or approved topsoil per Section 75.04 - Planting Soil. Use of existing soil must meet all Planting Soil requirements of Section 75.04. When holes are approximately two-thirds (2/3) full, soil shall be thoroughly watered to eliminate air pockets. Planting pits and beds shall be backfilled carefully as specified to fill all voids and to avoid breaking root ball or bruising roots. If settling of the backfill occurs after watering, add more backfill to bring to finish grade. A continuous 3" temporary soil berm shall be formed at the periphery of each tree or shrub to act as a watering basin. This berm shall be repaired as necessary to continue functioning throughout the maintenance period. It shall be removed at Landscaping Acceptance and replaced with 3" mulch.

H. Trees Plantings

A continuous three-inch height (3") temporary berm shall be formed around the extent of the planting pit of each tree planted to act as a watering basin, except where noted on the Drawings and/or details.

Trees planted on a slope shall have a continuous three inch height (3") temporary berm on the lower side of the slope around the extent of the planting pit of each tree planted to act as a watering basin, except where noted on the Drawings and/or details.

The temporary berm shall be repaired as necessary to continue functioning throughout the maintenance period and shall remain in place throughout the maintenance period. The temporary berm shall be removed at landscape acceptance and replaced with mulch as noted on the Drawings.

I. Shrub Plantings

A continuous three-inch height (3") temporary berm shall be formed around the extent of the planting pit of each shrub planted to act as a watering basin, except where noted on the Drawings and/or details.

Shrubs planted on a slope shall have a continuous three-inch height (3") temporary berm on the lower side of the slope around the extent of the planting pit of each shrub planted to act as a watering basin, except where noted on the Drawings and/or details.

The temporary berm shall be repaired as necessary to continue functioning throughout the maintenance period and shall remain in place throughout the maintenance period. The temporary berm shall be removed at landscape acceptance and replaced with mulch as noted on the Drawings.

J. Ground Cover, Perennials, and Annuals

Excavate a hole sufficient to receive the root spread and backfill around plants with topsoil and tamp soil to hold plant in place. The ground cover shall be planted in alternate rows, unless otherwise specified.

K. Watering

Thoroughly water each plant immediately following planting. Under no condition shall plants not be watered in the same day as planting. The Contractor shall water per maintenance specifications, Article 2.4, SubArticle B – Watering. The Contractor shall assume full responsibility for plant failure as a direct result of insufficient watering. Upon directive from the Engineer, the Contractor shall remove the affected plants and replace them immediately. Replacement of plants is considered incidental to the Contract and no separate payment shall be made.

L. Mulching

After planting has been approved by the Engineer, mulch materials as specified shall be placed and spread where and to the depth indicated on the Drawings. The boundaries of this mulch shall include planting-saucers around the trees and shrubs unless otherwise indicated. Mulch shall be pulled back four to six inches (4" to 6") from the tree trunk and three to six inches (3" to 6") from the main stem of the shrub.

M. Pruning and Repair

The only pruning allowed at planting shall be removal of dead, damaged, or broken branches and roots. Pruning shall conform to the American National Standard for Tree Care Operation, ANSI A300. No pruning paint or other wound dressing shall be used.

N. Staking

The Contractor shall stake only if necessary. Ties made of approved material shall be attached directly to the stakes or attached to the stakes by wire. In no case shall the wire extend around the tree trunk, even if covered by a hose.

Ties shall be attached loosely enough to allow the trunk to sway in the wind

without allowing movement to the roots. Ties shall be secured at the lowest point on the trunk at which the root ball remains stationary, approximately one-third up the tree. Stakes shall be driven outside the root ball and eighteen inches (18") into solid ground. Tops of stakes shall be cut off above ties so they do not damage the branches.

For trees larger than three inches (3") in caliper, ties shall be attached to three guy wires and ground anchors or stakes as detailed in the Drawings. Anchors or stakes shall be driven at a forty-five degree (45°) angle to the ground and placed at one hundred and twenty degree (120°) intervals around the trunk. Staking and guying shall conform to the Drawings.

The Contractor shall remove all stakes, ties, and guy wires one year after installation. The stakes, ties and wires are the property of the Contractor.

O. Clean-up

The Contractor shall keep the project site, and all roads and trails utilized during the project, clean and free of trash, excess equipment, materials, and rubbish, including sweeping and washing of trails and pedestrian facilities. Cleanup will be one of the conditions to be met prior to all phases of planting acceptance.

P. Winter Shut-down

Winter shut-down of all installation work shall occur between October 1 and May 1 of the following spring. During winter shutdown periods or work suspensions, the Contractor shall comply with Division 10 – Standard General Provisions regarding responsibilities and protection of all Work under the Contract.

Q. Plant Replacement

A tree is considered dead when the main leader has died back or when twenty-five (25%) of the crown is dead. Contractor shall provide plant material replacements of the same size, type and requirements as specified on the plant schedule. The Contractor shall repair to the satisfaction of the Engineer, or replace dead or damaged plant materials at no additional cost to the Owner, within five (5) working days after receiving written notice to do so by the Engineer. If Work is not completed to the Engineer's approval within the time limitation, the Engineer may exercise the option to have a contractor of the Owner's choosing perform the Work. If this option is exercised, the cost of that Work will be the responsibility of the Contractor and the Owner shall withhold payment to the Contractor in enough to recover those costs.

R. Acceptance of Initial Planting Operations

Upon completion of all initial planting operations (planting and seeding), the Contractor shall, per Division 10, Section 10.05, Article 5.26 – Final Inspection, submit a written request for an inspection of plant material.

Initial planting operation ends when:

1. All plants are installed, mulched and watered as specified;
2. Stakes and guys are in place;

3. All construction material and excess excavated material is removed and clean-up is completed;
4. Planting area is free of weeds or any unspecified plants; and
5. Plant material is healthy and vigorous.

Upon written acceptance of all Work by the Engineer, the one-year Plant Establishment Period shall begin.

Plant Establishment Period: From Acceptance of Initial Planting Operations the Contractor shall be responsible for maintaining the accepted plantings and seeded area for one year. During the Plant Establishment Period, the Contractor shall also, upon receipt of written notification by the Engineer, repair or replace damaged trees, shrubs, and perennials. If trees or shrubs are replaced within the last 60 days of the Plant Establishment Period, the Plant Establishment Period shall be extended an additional 60 days.

Article 2.4 Maintenance

A. General

The Contractor shall furnish all labor, materials, supplies and equipment required to establish, maintain, and protect the planted and seeded areas, for a Plant Establishment Period, one year in length, starting on the date of acceptance of the initial planting operations. However, maintenance activities shall commence immediately after each item is planted or when areas have been seeded. The Plant Establishment Period may be extended and paid in monthly increments beyond the first year at the direction of the Engineer.

The Contractor shall supply a maintenance schedule to the Engineer, thirty (30) days prior to the landscape inspection. The Contractor shall also be responsible for protection of his work during the maintenance period and shall repair and replace all materials and seeded areas damaged or destroyed within the scope of the Work, regardless of cause.

The Contractor's staff shall include supervisory personnel experienced in landscape maintenance. The Work Force is to be experienced and familiar with maintaining plant material in subarctic conditions.

Contractor shall replace any damaged tree or shrub at no additional cost to the Owner, regardless of the cause of the damage

B. Watering

A proposed watering schedule shall be submitted to the Engineer thirty (30) days prior to installation of plant materials. The Contractor shall notify the Engineer of watering activities. The Contractor shall keep a log of date, time of day, and amount of water used for every watering activity.

The Contractor shall deep water all trees and shrubs, providing water penetration throughout the root zone to the full depth of the planting pits. Deep water application shall be applied at a low-pressure application rate using hand watering with a hose with a minimum of water run-off. A tree watering bag system may be used at the Contractor's discretion and per the manufacturer's instructions.

Watering shall cease at first hard frost in the fall and shall resume upon ground thaw in the spring.

If at any time during the maintenance period weather conditions (such as extended period with no rain or continuous drying winds) cause the plant root zone to dry out, the Engineer may direct the Contractor to deep water all trees and shrubs. Contractor shall provide supplemental watering immediately and at no additional cost to the Municipality.

Should soil conditions be encountered that are not conducive to water absorption, the Contractor shall take whatever corrective actions that may be required to correct this condition, without additional cost to the Owner.

Turf, seeded, bulb areas, groundcover, perennial, and annual flower beds shall be watered at such frequency as weather conditions require to maintain soil moisture within the root zone. When establishing turf and seeded areas, the soil shall be watered often enough to maintain a moist seedbed to promote healthy seed germination resulting in an even and uniform coverage. If the Contractor does not provide adequate watering as required by the Engineer, the Engineer will hire others to perform this task and deduct costs from final payment to the Contractor.

C. Pruning

Pruning shall only be conducted for repair or as specified by the Engineer. Pruning shall conform to ANSI 300 Standards and shall be done under the supervision of a certified arborist. Dead, broken, or damaged branches may be pruned at any time. Pruning for form shall begin no sooner than two years after installation. No tree shall be topped. Any tree damaged by improper pruning shall be replaced by the Contractor.

D. Staking and Guying

Stakes and guys, where used, are to be inspected and adjusted as necessary throughout the maintenance period to prevent girdling of trunks or branches, and to prevent rubbing that causes bark wounds. Damaged or missing tree stakes shall be immediately replaced by the Contractor at no additional cost to the Owner. Contractor shall remove staking after the first year, unless the Engineer requests them to be left on longer. Unless otherwise specified, stakes shall be removed at the end of warranty.

E. Plant Repair and Replacement

The Contractor shall repair/replace damaged or defective plant materials, regardless of cause, immediately upon notification by the Engineer. Defective plants shall be defined as plants not meeting these requirements. Repair shall include pruning, guying, staking, etc., as necessary. Should repair of plant materials reduce their acceptance to less than minimum specified conditions, the Contractor shall replace plants with specified plant replacements at no additional cost to the Owner.

F. Fertilization and other Chemical and Biological additives

If the construction or maintenance period extends into a second growing season, representative soil tests from the project site shall be taken by the Contractor and

submitted to an approved testing lab no later than May 5 for fertility testing. The results of these tests and recommendations for application of additives shall be provided to the Engineer and will be the basis for establishing required application rates. All necessary applications shall be completed prior to June 15 or before the end of the maintenance period, whichever occurs first.

Formulations will vary according to soil tests.

G. Diseases and Pests

The Contractor shall coordinate with the Engineer in the event that disease, invasive plant infestation, or pest problems are observed on plants within a Project area. The Contractor and the Engineer shall formulate an Integrated Pest Management program to control the disease, invasive plants, or pests. The IPM program can use biological, physical, cultural, behavioral, and chemical methods to resolve the issue. Chemical pesticides are to be used only when other options are not feasible or effective. If pesticides are used, the least toxic pesticide to accomplish the task shall be used. Any pesticide application will be done by a certified pesticide applicator and will be done in compliance with Title 18, Chapter 90 of the Alaska Administrative Code and Anchorage Municipal Code 15.75.

The Contractor shall apply all materials in complete compliance with all State, Federal, and local regulations, and shall supply the Engineer written proof of their safety and acceptability by State, Federal and Local jurisdictions.

In the event a "restricted use" pesticide is to be applied, the Contractor shall obtain appropriate permits and certifications (according to current 18 AAC 90 Pesticide Control) from the State of Alaska, Department of Environmental Conservation. Proof of certification shall be transmitted to the Engineer prior to application of the chemicals.

H. Weeding

The Contractor shall maintain all areas in a weed-free condition. Weed removal shall be a routine maintenance activity. Chemical application must be in compliance with State of Alaska rules and regulations and Anchorage Municipal Code 15.75.

I. Cleanup

The Contractor shall keep the project site clean and free of all trash and excess equipment, materials, rubbish, including plant tags, wire, burlap, ribbon, and all debris found within the Project limits, including all roads and trails utilized during Construction. Cleanup will be one of the conditions to be met prior to acceptance of landscape installation and Final Acceptance.

J. Other Tree and Shrub Maintenance

To protect coniferous trees during the winter from excessive desiccation, apply an anti-desiccant such as "Wilt-Pruf" (or equal approved by the Engineer prior to procurement) prior to the winter shut-down period. Complete coverage of all foliage is required.

K. Inspection

The Engineer shall make periodic maintenance inspections of the work. All deficiencies noted shall be corrected within five (5) calendar days from written notice, at no additional cost to the Owner. All delays beyond the five-day period shall result in an equal number of days added to the one year Plant Establishment Period.

L. Mowing

Areas seeded (or sodded) with Schedule A and E seed mix shall be mowed each week or when grass exceeds a height of two and one-half inches (2.5"). Clippings shall not be caught and removed unless they are determined by the project Engineer to be unsightly or damaging to the lawn. Contractor is not to mow areas seeded with Schedules B, C and D seed mix, unless otherwise directed by the Engineer for the purpose of mechanical weed control or site distance issues.

Seeded areas will be mowed on a regular schedule as part of the routine maintenance during the Plant Establishment Period. A copy of the mowing schedule will be provided to the Engineer. The final mowing of the grass in the fall and prior to the Seeding Acceptance inspection should be at a height of two inches (2").

Article 2.5 Landscaping Acceptance

A Landscaping Acceptance Inspection of the project will occur after completion of the Plant Establishment Period. Engineer shall verify that Contractor performed maintenance functions as identified in Article 2.4 – Maintenance of this Section. Additional conditions governing Landscaping Acceptance of the planted and seeded areas are that, in the opinion of the Engineer, all plants are in a live, uniform, and sound and healthy and flourishing condition; free of disease, insect infestation and physical damage, and free of weeds, rubbish and construction debris. The Engineer shall verify that all Moose Protection Fencing has been removed as specified. Fencing shall be allowed to remain only at the direction of the Owner. If the Engineer does not accept the plantings and removal of Fencing, the Contractor shall correct all deficiencies. All costs associated with correcting the deficiencies and extending the Plant Establishment Period shall be paid by the Contractor without additional cost to the Owner.

Should required corrections not be made within thirty (30) days after the initial Landscaping Acceptance Inspection, the Contractor shall be assessed liquidated damages per Division 10, Section 10.05, Article 5.27 – Liquidated Damages, until all Work is complete and accepted by the Engineer.

Article 2.6 Measurement

Seventy percent (70%) of each bid item shall be measured as quantity of plants by individual plant count, or by area as specified.

The remaining thirty percent (30%) of each bid item shall be measured as maintenance Work performed during the Plant Establishment Period and the acceptance of the landscaping improvements in the condition identified in Article 2.5 of this Section. Payment process and exceptions are identified in Article 2.7 below and in Division 10, Section 7.7 – Final Payments.

Article 2.7 Basis of Payment

Payment for this Work shall be in accordance with Division 10, Section 10.07 - Measurement and Payment, and shall include full payment for all Work described in this Section.

Payment for all trees, shrubs, and perennials includes payment for the Plant Establishment Period. Extensions of the Plant Establishment Period beyond the one year minimum as specified in Special Provisions shall be paid separately. Extensions of the Plant Establishment Period due to rejection of the work by the Engineer or replacement of damaged materials shall be performed at the Contractor's expense. Owner will pay the accepted quantity of trees, shrubs and perennials after the Acceptance of Initial Planting Operations, based on seventy percent (70%) of the Contract unit price for the respective pay items. Mulch is considered incidental to the Work described in Section 75.02. unless otherwise noted.

The remaining thirty percent (30%) for the maintenance during the Plant Establishment Period shall be paid upon Landscaping Acceptance except as noted below. The Engineer shall make inspections before payment. The Engineer shall be the sole judge of the conditions of quality and acceptability and will direct inspection reports to the Contractor in writing. Work rejected by the Engineer will not receive payment for that month.

If Contractor did not perform maintenance in accordance with Article 2.4 – Maintenance, the remaining 30% shall not be paid.

If damaged trees, shrubs, and perennials are not repaired or replaced as required within fourteen (14) days of written notice, the Engineer may replace or have replaced the damaged items and deduct the cost of said repair or replacement work from the remaining payments. The cost of said repair or replacement work is based on receipts for replacement plants, shrubs, or trees plus ten percent (10%) administrative markup. Replacement by the Owner of any plantings within the last sixty (60) days of the Plant Establishment Period shall trigger a sixty (60) day extension of the Plant Establishment Period.

Payment shall be made on the following basis:

ITEM	UNIT
Trees (by species and size as indicated on Drawings)	Each
Shrubs (by species and size as indicated on Drawings)	Each
Ground Cover (by species and size)	Each
Perennials (by species and size)	Each
Annuals (by the species and size)	Each
Extended Plant Establishment Period (by month)	Each

SECTION 75.03 PLANTING SOIL

Article 3.1 General

The Work under this Section consists of providing all operations pertaining to furnishing, transporting, and spreading of planting soil.

A. Applicable Standards

1. ASTM D422 Standard Test Method for Particle Size Analysis of Soils
2. ASTM D2974 Standard Test Method for Moisture, Ash and Organic Matter of Peat and Other Organic Soils
3. ASTM D2434 Standard Test Method for Measurement of Hydraulic Conductivity of Coarse-Grained Soils
4. ASTM D1556 Standard Test Method for Laboratory Compaction Characteristics of Soil Using Modified Effort
5. AASHTO T 267 Standard Method of Test for Determination of Organic Content in Soils by Loss of Ignition
6. US Council Seal of Testing Assurances (STA)/Test Methods for Examining of Composting and Compost (TMECC) criteria

B. Submittals

1. Topsoil: lab analysis results
2. Limestone Fertilizer: product data and the manufacturer's guaranteed analysis of the contents
3. Compost: a two-gallon sample of the compost and the STA Program certified lab analysis results

Article 3.2 Materials

The Contractor shall furnish soil analysis test reports to the Engineer ten (10) days prior to final placement for Engineer comment or acceptance.

A. Planting Soil

Planting Soil furnished by the Contractor shall consist of a natural friable surface soil without admixtures of undesirable subsoil, refuse, or foreign materials. It shall be shredded and free from roots, hard clay, rocks larger than one inch (1"0 in any dimension, weeds, noxious plants, seeds, or plant propagules, tall grass, brush, sticks, stubble, or other litter, and shall have indicated by a healthy growth of crops, grasses, trees, or other vegetation that it is free-draining and non-toxic. Planting Soil shall contain not more than ten percent (10%) gravel by dry weight of total sample. For the purposes of this specification gravel is defined per ASTM D422 modified to include only material passing on inch (1") and retained on the No. 4 sieve.

The Contractor shall provide the Engineer with a copy of the lab analysis verifying that the topsoil meets the product parameters stated in this specification. The lab analysis shall not be more than 90 days old. Planting soil shall conform to the following requirements, as tested using the procedures included in ASTM D422, ASTM D2974, and AASHTO T267. The topsoil shall be tested and inspected by the Engineer before approval will be granted for its use.

Organic material for incorporation into planting soil, shall be partially decomposed peat moss. Organic material shall be from a source above the water table. Peat moss may require chopping or shredding to ensure thorough mixing with the topsoil. Organic matter is to be determined by loss-on-ignition of oven-dried material in accordance with ASTM D2974.

1. Planting Soil shall consist of the following:

a. Topsoil

Topsoil shall be used in the planting of trees, shrubs, perennials and/or all new planting materials furnished as B&B or potted unless otherwise noted in the Drawings. Topsoil for planting is incidental to Work described in Section 75.02 and no payment shall be made under this Section. Topsoil for seeding shall be used with Schedule A, B, C, and D Mixes, unless otherwise noted in the Drawings, and payment shall be made under this Section.

Topsoil Mix:

Organic Material	Silt	Sand
15% to 25% by total sample dry weight	25% to 45% by dry weight	35% to 55% by dry weight

b. Athletic/Sports Field Topsoil

Athletic/Sports Field Topsoil shall be used for Athletic/Sports Fields with Schedule E Seed Mix, unless otherwise noted in the Drawings.

Topsoil Mix for Athletic/Sports Fields:

Organic Material	Silt	Sand
15% to 25% by volume	20% to 35% by volume	50% to 55% by volume

c. Sports Field/Infield Loam

Sports Field/Infield Loam shall be used in sports fields in areas intended to be free of grass and other vegetation, unless otherwise noted in Drawings.

Topsoil Mix for Loam

Organic Material	Silt	Sand
0.0% by volume	75% to 85% by volume	15% to 25% by volume

d. Engineered Soil for Stormwater Treatment

Engineered Soil for Stormwater Treatment shall be used in bioretention or stormwater infiltration areas, as noted in the Drawings.

The final soil mix (including compost and soil) shall have a long-term hydraulic conductivity of approximately 1.0 inch/hour. Note that infiltration rate and hydraulic conductivity are assumed to be approximately the same in a uniform mix soil.

The pH for the soil mix should be between 5.5 and 7.0. If the pH falls outside of the acceptable range, it may be modified with lime to increase the pH or iron sulfate plus sulfur to lower the pH. The lime or iron sulfate must be mixed uniformly into the soil prior to use in the bioretention system.

The final soil mixture should be tested by an independent laboratory prior to installation for fertility, micronutrient analysis, and organic material content. Soil amendments per laboratory recommendations (if any) should be uniformly incorporated for optimum plant establishment and early growth.

It shall be uniform and free of stones, stumps, roots, or other similar organic matter greater than 2" diameter.

The final soil mixture shall be tested per:

ASTM Designation D 2434 (Standard Test Method for Hydraulic Conductivity of Coarse-Grained Soils)

ASTM Designation D 1557 (Standard Test Methods for Laboratory Compaction Characteristics of Soil Using Modified Effort)

ASTM Designation D 2974 (Standard Test Method for Moisture, Ash and Organic Matter of Peat and Other Organic Soils)

Topsoil Mix for Engineered Soil for Stormwater Treatment:

Hydraulic Conductivity at 80% compaction	1.0 inch/hour
Minimum Organic Content	10% by dry weight
Clay Content	Less than 5%
pH	5.5 to 7.0

e. Modified Existing Soil – soil removed, stockpiled, and spread

Existing soil that is suitable for reuse as Planting Soil but is in the wrong place or elevation, or cannot be adequately protected during construction. Soil is to be harvested, stockpiled and re-spread with or without further modifications as indicated.

i. Modifications:

- a. Excavate existing soil from the areas and to depths designated on the drawings. Stockpile in zones noted on the drawings or in areas proposed by the Engineer.
- b. Contractor to prepare a soil stockpile plan for approval
- c. Excavate soil using equipment and methods to preserve the clumps in the soil. Generally this means using the largest piece of equipment that is practical for the project size and scope.
- d. Protect stockpiles from erosion by compacting or tracking the soil surface, covering with breathable fabric or planting with annual grasses as appropriate for the season, location, and length of expected time of storage.

B. Soil Amendments

1. Fertilizer shall be a standard inorganic or organic commercial grade supplied separately or in mixtures and furnished in moisture-proof containers. Each container shall be marked with the weight and the manufacturer's guaranteed analysis of the contents showing the percentage for each ingredient contained therein. The proportion of chemical ingredients furnished shall be a mixture such as to provide the total available nitrogen, phosphoric, and potassium as required by the soil analysis or as specified in the Special Provisions. At least five (5) days prior to placement, the Contractor shall submit to the Engineer for approval an analysis of the proposed fertilizer and Manufacturer's Certificate of Compliance indicating Specifications are met.

Tolerances of the chemical ingredients shall be plus or minus two percent ($\pm 2\%$).

No cyanamid compounds or hydrated lime will be permitted in mixed fertilizers.

2. Limestone shall contain not less than eighty-five percent (85%) of calcium and magnesium carbonates. Agricultural ground limestone suitable for application by a fertilizer spreader shall conform to the following gradation:

Sieve Designation	Minimum Percent Passing by Weight
#10	100
#20	90
#100	50

Pelletized limestone may be used subject to approval by the Engineer.

Fertilizer and limestone for use in a hydraulic sprayer shall be soluble or ground to a fineness that will permit complete suspension of insoluble particles in water.

3. Compost

Compost shall be a well decomposed, stable, weed-free organic matter source designed to produce Compost high in fungal material. It shall be derived from: agricultural, food, or industrial residuals: biosolids (treated sewer sludge); yard trimmings; source-separated or mixed solid waste. The product shall contain no substances toxic to plants and shall be reasonably free (<1% by dry weight) of man-made foreign matter. The compost will possess no objectionable odors and shall not resemble the raw material from which it was derived.

Compost shall be commercially prepared compost and shall meet US Council Seal of Testing Assurance (STA)/Test Methods for Examining of Composting and Compost (TMECC) criteria.

Before delivery of compost, the Contractor must provide the Engineer with a copy of the lab analysis, performed by a STA Program certified lab, verifying that the compost meets the product parameters stated in this specification. The lab analysis should not be more than 90 days old.

Provide a two-gallon sample with manufacturer’s literature and material certification that the product meets the following requirements.

Compost shall comply with the following parameters:

pH	5.5 to 8.0
Soil Salt (electrical conductivity)	Maximum 5 dS/m (mmhos/cm)
Moisture content (% wet weight basis)	30 to 60
Organic Matter (% dry weight)	30 to 60
Particle size	98% pass through ¾ inch screen
Stability carbon dioxide evolution rate	Mg CO ₂ -C/g OM/day < 2
Solvita maturity test	>6
Physical contaminants/inerts (% dry weight)	<1%
Chemical contaminants, mg/kg (ppm)	Meet or exceed US EPA Class A standard, 40 CFR 503.13, Tables 1 and 3 levels
Biological contaminants (select pathogens, fecal coliform bacteria, or salmonella)	Meet or exceed US EPA Class A standard, 40 CFR 503.32(a) level requirements

Sufficient fertilizer, limestone, and/or compost shall be applied to the planting soil such that the total natural and applied chemical constituents are within the following ranges:

Nitrogen 30-50 PPM

Phosphoric Acid	60-110 PPM
Potassium	76-150 PPM
Limestone	Sufficient to attain a PH of 6.0 to 7.0

Article 3.3 Placing

Placement of Planting Soil (Topsoil, Engineered Soil, Modified Existing Soil, or other as specified) shall not occur until the project area has been inspected and approved by the Engineer. Prior to installing any soil from stockpiles or mixes blended off site, the Engineer shall approve the condition of the subgrade, the previously installed subgrade preparation, and the installation of subsurface drainage.

In areas of specified soil installation above existing subsoil, scarify the subgrade material to the depth of 3 to 6 inches with the teeth of the backhoe or bucket loader, tiller or other suitable device prior to installing Topsoil.

In the event that the loosened subgrade area becomes overly compacted, loosen the area again prior to installing the Planting Soil.

The Contractor shall protect installed Planting Soil from damage including contamination and over compaction due to other soil installation, planting operations, and operations by other Contractors or trespassers. Maintain protection during installation and other site work construction until acceptance. Utilize fencing and matting as required or directed to protect the finished soil work. Treat, repair or replace damaged Planting Soil immediately.

Where travel over installed topsoil is unavoidable, limit paths of traffic to reduce the impact of compaction on Planting Soil. Each time equipment passes over the installed soil it shall reverse out of the area along the same path with the teeth of the bucket dropped to scarify the soil.

Loosen compacted Planting Soil and replace Planting Soil that has become contaminated as determined by the Engineer. It shall be loosened or replaced at no expense to the Owner. Till and restore grades to all soil that has been driven over or compacted during the installation of plants or seed.

Planting Soil stockpiled for project use shall be protected to prevent erosion and weed growth.

Contractor shall not place or spread any Planting Soil when the ground or topsoil is frozen, excessively wet, or otherwise in a condition detrimental to the Work.

Contractor shall keep roadway surfaces within the project area and on haul routes clean during hauling and spreading operations.

- A. Topsoil for Planting and Seeding: For planting beds, topsoil shall be at the depth shown on the Drawings, but no less than 12". Where possible, place large trees first and fill the Topsoil around the root ball.

For seeding operations, the topsoil shall be evenly spread on the designated areas to a depth of four inches (4") after settlement unless otherwise specified on the Drawings. Settlement for seeded areas shall be achieved by rolling the topsoil with a water-filled drum approved by the Engineer. The Engineer may direct that topsoil placed on slopes be track-walked perpendicular to the slope with a small track dozer. Track walking shall be incidental to this bid item and no separate payment shall be made.

- B. Athletic/Sports Field Topsoil: Athletic/Sports Field Topsoil shall be evenly spread on the designated areas to a depth of six inches (6") after settlement unless otherwise specified on the Drawings. Settlement for seeded areas shall be achieved by rolling the topsoil with a water-filled drum approved by the Engineer.
- C. Sports Field/Infield Loam: Loam shall be evenly spread on the designated areas to a depth of six inches (6") after settlement unless otherwise specified on the Drawings. Settlement for these areas shall be achieved by rolling the topsoil with a water-filled drum approved by the Engineer.
- D. Modified Existing Soil: The preparation, storage, and application of the Modified Existing Soil shall be as follows:
 - a. Scarify designated Modified Existing Soil placement areas to a depth of six (6) inches prior to the placement of the soil.
 - b. The Modified Existing Soil shall be placed at a depth of four (4) inches and shall be worked thoroughly into the underlying subgrade. Viable roots shall be sufficiently buried in the soil and subgrade.

Article 3.4 Measurement

Planting Soil is measured as the number of 1,000 square foot units measured to the nearest

0.1 unit applied to the ground surface. Stockpiling and/or re-handling of topsoil during stripping operations, or during placement, shall not be measured for payment.

Planting soil placed in planting beds and for individual tree and shrub plantings is incidental to Work described in Section 75.02 and no payment shall be made under this Section.

Fertilizer is incidental to Work described in this Section and no payment shall be made under this Section.

Article 3.5 Basis of Payment

Payment for this Work shall be in accordance with Division 10, Section 10.07 - Measurement and Payment, and shall include full payment for all Work described in this Section.

Unit cost payment shall be made on the following basis:

ITEM	UNIT
Topsoil (Depth)	1,000 Square Feet (MSF)
Athletic/Sports Field Topsoil (Depth)	1,000 Square Feet (MSF)
Sports Field/Infield Loam (Depth)	1,000 Square Feet (MSF)
Modified Existing Soil (Depth)	1,000 Square Feet (MSF)
Engineered Soil for Stormwater Treatment (Depth)	1,000 Square Feet (MSF)
Compost (Depth)	1,000 Square Feet (MSF)

DRAFT

SECTION 75.04 SEEDING

Article 4.1 General

The Work under this Section shall consist of providing all labor, equipment, and materials for the preparation of ground surfaces for the application and maintenance of seeded areas, fertilization, lime application (if necessary), watering, and mulching at locations shown on the Drawings or established by the Engineer.

All seeding shall be performed between May 1 and September 1. Seeding any other time will only be allowed upon written approval from the Engineer. Seeding shall not be done during windy conditions or when climatic or ground conditions would hinder placement or proper germination of seed mixes.

A. Submittals

1. Seed testing certification
2. Certification tags
3. Analysis of the proposed fertilizer and Manufacturer's Certificate of Compliance indicating Specifications are met.
4. Product Data

Article 4.2 Materials

A. Seed

Seed shall be certified and shall be furnished in standard containers with the seed name, lot number, net weight, percentages of purity and of germination and hard seed, and percentage of maximum weed seed content clearly marked for each kind of seed. The Contractor shall furnish the Engineer with duplicate signed copies of a statement by the vendor certifying that each lot of seed has been tested by a recognized laboratory for seed testing within a 9-month period prior to application. This statement shall include name and address of laboratory, date of test, lot number for each kind of seed, and the results of tests as to name, percentages of purity and of germination, and percentage of weed content for each kind of seed furnished and, in case of a mixture, the proportions of each kind of seed. Seed that has become wet, moldy, or otherwise damaged in transit or storage will not be acceptable. If species/cultivars listed are unavailable then the Contractor shall submit availability for review and approval.

The Contractor shall submit to the Engineer a certification tag for the seed mixes provided listing species, proportion by weight, percent purity, and percent germination. The certification tag shall come from the specified seed mixes and be removed from the unopened bags in the presence of the Engineer. Contractor shall deliver seed to the site in its original unopened container, which shall bear the vendor's guarantee of analysis.

Seed shall conform to one of the following seed mix types and application rates:

Schedule A: Mowable/Turf Seed Mix

Application Rate: 4 lbs./1000 s.f.

Name	Proportion by Weight
Red Fescue (<i>Festuca rubra</i> – ‘Boreal,’ ‘Oracle,’ ‘Arctared’)	35%
Kentucky Bluegrass (<i>Poa pratensis</i> ‘Kenai’)	35%
Kentucky Bluegrass (<i>Poa pratensis</i> - ‘Baron,’ ‘Shamrock’)	25%
Annual Ryegrass (<i>Lolium multiflorum</i>)	5%

Schedule B: Grass and Wildflower Seed Mix

Application Rate: 2 lbs./1000 s.f.

Name	Proportion by Weight
Gruening Alpine Blue (<i>Poa alpina</i> ‘Gruening’)	30%
Red Fescue (<i>Festuca rubra</i> – ‘Boreal,’ ‘Oracle,’ ‘Arctared’)	20%
Perennial Lupine (<i>Lupinus perennis</i>)	20%
White Yarrow (<i>Achillea millefolium</i>)	10%
Dwarf Columbine (<i>Aquilegia vulgaris</i>)	10%
Rocket Larkspur (<i>Delphinium consolida</i>)	10%

Schedule C: Wetland Seed Mix

Application Rate: 2 lbs./1000 s.f.

Name	Proportion by Weight
Nortran Tufted Hairgrass (<i>Deschampsia caespitosa</i> 'Nortran')	45%
Egan American Slough (<i>Beckmannia syzigachne</i> 'Egan')	40%
Red Fescue (<i>Festuca rubra</i> – 'Boreal,' 'Oracle,' 'Arctared')	15%

Schedule D: Revegetation Seed Mix

Application Rate: 2 lbs./1000 s.f.

Name	Proportion by Weight
Nortran Tufted Hairgrass (<i>Deschampsia caespitosa</i> 'Nortran')	60%
Red Fescue (<i>Festuca rubra</i> – 'Boreal,' 'Oracle,' 'Arctared')	30%
Annual Rye (<i>Lolium multiflorum</i>)	10%

Schedule E: Athletic Field Seed Mix

Application Rate: 4 lbs./1000 s.f.

Name	Proportion by Weight
Kentucky Bluegrass Kenai (<i>Poa pratensis</i> 'Kenai')	25%
Kentucky Bluegrass Baron (<i>Poa pratensis</i> 'Baron')	25%
Kentucky Bluegrass Shamrock (<i>Poa pratensis</i> 'Shamrock')	25%
Red Fescue (<i>Festuca rubra</i> – 'Boreal,' 'Oracle,' 'Arctared')	20%
Perennial Ryegrass (<i>Lolium perenne</i> – 'Manhattan,' 'Pinstripe')	5%

B. Soil Amendment

A biodegradable Hydraulic Biotic Soil Amendment (HBSA), such as 'Verdyol,' 'Proganics,' or equal approved by the Engineer prior to procurement may be substituted for topsoil for areas to be seeded.

HBSAs are engineered to improve the development of deficient soils and to facilitate sustainable vegetation. HBSAs typically consist of organic material and nutrient sources combined with soil building and biostimulant components designed to facilitate faster plant growth as well as sustained long term growth. The blend of organic and natural fibers with fast-acting soil building and growth components increase the water and nutrient holding capacity of the soil and create an environment for growth of beneficial microorganisms while allowing seed germination and vegetation establishment.

Provide a HBSA that is composed of non-toxic materials. Use HBSA materials certified to be weed seed free. Additional seed, fertilizer, tackifier, and/or any other soil amendments may be needed to mix with or be used in conjunction with the HBSA for application as determined by the Engineer or recommendations by the product manufacturer.

Certain HBSAs may help achieve a minimal level of erosion control but may not replace the use of erosion control products. Strictly follow manufacturer's delivery, storage, handling, and installation requirements.

C. Fertilizer

Fertilizer shall meet requirements as identified in Section 75.03 Planting Soil Article 3.2 Materials Soil Amendment Section.

D. Limestone

Limestone shall meet requirements as identified in Section 75.03 Planting Soil Article 3.2 Materials Soil Amendment Section.

E. Hydroseeding Mulch

Shall be dried shredded peat moss or cellulose wood or paper fiber such as "Astromulch," "Eco Fiber," "Conwed," or equal approved by the Engineer prior to procurement.

F. Water

Water used in all operations shall be of potable quality.

Article 4.3 Application

A. Soil Preparation

After grading of areas has been completed in conformity with the lines and grades shown on the Drawings, and before beginning seeding operations, the areas to be seeded shall be cultivated to provide a reasonably firm but friable seedbed. Cultivation shall be carried to a depth of two inches (2"). On slopes steeper than 3:1, depth of cultivation may be reduced as directed by the Engineer. All areas to be cultivated shall be raked or cleared of stones (one inch [1"] in diameter and larger), weeds, plant growth, sticks, stumps, and other debris or irregularities which might interfere with the seeding operation, germination of seed, or subsequent maintenance of the seed-covered areas. Cultivation shall include the entire ground surface, regardless of existing ground cover. Contractor may be required to track-walk slopes 2:1 or over as directed in the Drawings or by the Engineer. Prior to seeding application, site inspection by the Engineer is required to confirm that preparation conditions are satisfactory for the seeding work to proceed.

B. Fertilizer

Fertilizer used with topsoil shall be applied at a rate to provide two (2) pounds actual Nitrogen per thousand (1,000) square feet of area. In the absence of soil tests and direction from the Engineer, the Contractor shall apply 16-16-16 at the rate of twelve and one-half (12.5) pounds per thousand (1,000) square feet. Fertilizer shall be in accordance with Section 75.04 - Topsoil.

When applying a fertilizer used with the soil amendment, the Contractor shall apply a natural /organic based fertilizer with 25% slow release materials such as Arctic Gro Biotic Fertilizer. The organic based fertilizer shall have a minimum guaranteed analysis of 10-10-10-8.5S. It should provide a minimum of 10% (N) nitrogen, 10% (P) phosphate, 10% (K) potash, and 8.5% (S) sulfur. The fertilizer shall contain Humic DG (Dispersing Granule) to promote microbial growth and soil fertility and Sustane Organic for greater root development. It should be in a granular form that is easily spread. Apply at five hundred pounds per acre (500 lbs/acre).

C. Limestone

Limestone, whether in liquid or dry form, shall be applied at a sufficient rate to attain a soil pH between 6.0 and 7.0.

D. Application Methods

All machinery shall be free of invasive weeds, seeds, or plant propagules. Apply seed mixtures as specified under Article 5.2, SubArticle A - Seed at rates as specified and/or as directed by the Engineer. Seed, fertilizer, limestone, mulch, and water may be applied by the following methods:

1. Hydraulic Method

Seeding by hydraulic methods shall consist of furnishing and placing a slurry made of seed, fertilizer, dried peat moss or cellulose wood fiber and water.

The dried peat moss or cellulose wood fiber shall be added to the water slurry in the hydraulic seeder after the proportionate amounts of seed and fertilizer have been added. The slurry mixture shall then be combined and applied in such a manner that the rate of application will result in an even distribution of all materials.

Hydraulic seeding equipment shall be capable of maintaining a continuous agitation so that a homogeneous mixture can be applied through a spray nozzle. The pump shall be capable of producing sufficient pressure to maintain a continuous, non-fluctuating spray capable of reaching the extremities of the seeding area with the pump unit located on the roadbed. Sufficient hose shall be provided to reach areas not practical to seed from the nozzle unit situated on the roadbed.

2. Dry Method

Mechanical spreader, seed drills, landscape seeder, cultipacker seeder, fertilizer spreader, or other approved mechanical spreading equipment may be used when seed and fertilizer are to be applied in dry form.

Fertilizer shall be spread separately at the specified rates, and then incorporated in one operation to a minimum depth of two inches (2"). Seeded areas shall be compacted within twenty-four (24) hours from the time the seeding is completed, weather and soil conditions permitting, by cultipacker, roller or other equipment satisfactory to the Engineer. Compacting equipment shall be operated at right angles to the slope. Compaction shall not be performed when the soil is in such condition that it will be picked up by the equipment, nor shall heavy soils be compacted unless directed by the Engineer.

3. Hand Method

Hand broadcasting by means of portable, hand operated mechanical spreaders or "by hand" may be substituted for the preceding two (2) methods provided that the application rate is twice that of the dry method, and that the

application is applied in a minimum of two (2) passes over the areas to be seeded (at ninety degrees [90°] to one another in order to assure uniform and even coverage to all seeded surfaces).

4. Hydraulic Biotic Soil Amendments

The area where the hydraulic biotic soil amendment (HBSA) is to be sprayed should be inspected by the Engineer prior to seeding operations to evaluate the need of tillage before application. If tillage is required, the soil should be loosened to a minimum depth of 3 inches before the application commences. For seedbeds on a slope, an acceptable method of preparation is vertically tracking the seedbed up and down using proper equipment.

As a quality assurance method, an area should be measured and stick delineated that matches the tank capacity of the hydroseeder equipment. The hydroseeder operator must totally empty the hydroseeder tank in the delineated area. This ensures that the soil equivalent dose is applied according to specification and homogeneously distributed. Prior to application, the soil must be inspected to evaluate the need for tillage (as described above). It is ideal to spray the material over a roughened area that allows the organic matrix or soil equivalent to stick to the soil.

HBSAs are typically applied using approved hydraulic methods and equipment. The type and size of the hydraulic equipment used can influence the mixing rate of the HBSA. Always follow the manufacturer's specifications and requirements when applying HBSAs. Mix additional seed, fertilizer, tackifier, and/or any other soil amendments with the HBSA before application. If erosion control products are to be used, they should be installed after application of the HBSA is complete. HBSAs should not be applied within 24 hours of recent rain or when rain is forecasted to occur within the next 24 hours unless protected by erosion control products. Follow instructions and/or recommendations from the manufacturer about appropriate conditions for application.

Avoid overspray onto roads, sidewalks, trails, boulders, plantings, and other improvements. All new plantings must be protected from overspray.

E. Erosion Control

Erosion Control shall be a fully biodegradable growth medium composed of 100% recycled and thermally refined wood fibers, crimped interlocking man-made biodegradable fibers, micro-pore granules, naturally derived cross linked biopolymers and water absorbents, such as 'Flexterra HP-FGM", or equal approved by the Engineer prior to procurement. The HP-FGM is phytosanitized, free from plastic netting and requires no curing period. Any approved equal must meet the following material composition:

Material Composition:

80% Thermally Processed Wood Fiber

10% Crosslinked Biopolymers and Water Absorbments

5% Crimped, Man-made Biodegradable Interlocking Fibers

5% Micro-Pore Granules

Application rates for 'Flexterra' and 'Verdyol Biotic Black Earth' (or approved equal) shall be as recommended by the manufacturer.

Article 4.4 Maintenance

All maintenance shall be in accordance with Section 75.02, Article 2.4 – Maintenance. Contractor maintenance requirement concludes when the one year Plant Establishment Period is successfully completed and the seeded area is accepted in accordance with Article 4.5 – Seeding Acceptance.

The Contractor shall protect seeded areas from damage from all traffic, whether people, animals, on or off-road vehicles, or any other causes which may damage newly seeded and maintained surfaces. Contractor shall maintain a minimum, uniform coverage of 90% in weed free condition. Surfaces damaged shall be repaired by regrading, reseeding (including all specified amendments), as directed by the Engineer, at no additional cost to the Owner. The Contractor shall otherwise maintain seeded areas, including regular mowing, in a satisfactory condition until Seeding Acceptance.

On the fortieth (40th) day of the maintenance period, the Contractor shall apply one application of fertilizer (16-16-16) at the rate of seven (7) pounds per thousand (1,000) square feet.

Article 4.5 Seeding Acceptance

A. Acceptance of Initial Seeding Operations

Upon completion of all initial seeding operations, the Contractor shall, per Division 10, Section 10.05, Article 5.26 – Final Inspection, submit a written request for an inspection of seeding.

Initial planting operation ends when:

1. Seeded area is installed, mulched and watered as specified;
2. All construction material and excess excavated material is removed and clean-up is completed;

Upon written acceptance of initial seeding operations by the Engineer, the Contractor may submit the first pay request as defined in Article 4.7.

B. Ninety Percent (90%) Uniform Coverage

When the Contractor believes that ninety percent (90%) uniform coverage of the seeded area has been obtained, the Contractor shall submit a written request for the ninety percent (90%) Coverage inspection. If the Engineer provides written concurrence that ninety percent (90%) of the seeded area is uniformly covered, healthy and weed-free, the Contractor may submit the second pay request as defined in Article 4.7.

C. Seeding Acceptance

A Seeding Acceptance Inspection of the project will occur after completion of the Plant Establishment Period. Engineer shall verify that Contractor performed maintenance functions as identified in Article 2.4 – Maintenance of this Section.

Additional conditions governing Seeding Acceptance of the seeded areas are that, in the opinion of the Engineer, the seeded area is in a live, uniform, and sound and healthy and flourishing condition; free of disease, insect infestation and physical damage, and free of weeds, rubbish and construction debris.

Upon written acceptance of the seeding, the Contractor may submit the final pay request as defined in Article 4.7.

If the Engineer does not accept the seeding, the Contractor shall correct all deficiencies. All costs associated with correcting the deficiencies and extending the Plant Establishment Period shall be paid by the Contractor without additional cost to the Owner.

Should required corrections not be made within thirty (30) days after the initial Seeding Acceptance Inspection, the Contractor shall be assessed liquidated damages per Division 10, Section 10.05, Article 5.27 – Liquidated Damages, until all Work is complete and accepted by the Engineer.

Article 4.6 Measurement

The measurement of seeding shall be the number of thousand (1,000) square foot units, measured to the nearest 0.1 unit complete, in-place, maintained, and accepted. The seeding bid item includes all labor and material; including cultivating, seed, hydraulic growth medium, erosion control, limestone, if required, appropriate fertilizer and mulch material of the type specified; to obtain seeding that is complete, maintained and accepted.

The measurement of seeding is broken into three milestones. The first stage is Acceptance of Initial Seeding Operations as defined in Article 4.5. The second is ninety percent (90%) coverage as defined in Article 4.5. The third is Seeding Acceptance as defined in Article 4.5. Progress payments, as defined in Article 4.7, will be made upon successful completion of each milestone.

Article 4.7 Basis of Payment

Payment for this Work shall be in accordance with Division 10, Section 10.07 - Measurement and Payment, and shall include full payment for all Work described in this Section.

Payment for seeding includes payment for maintenance during the Plant Establishment Period. Owner will pay the accepted quantity seeding after the Acceptance of Initial Planting Operations, based on thirty percent (30%) of the Contract unit price for seeding. An additional forty percent (40%) will be paid upon the Engineer's concurrence that ninety percent (90%) coverage has been obtained. The remaining thirty percent (30%) for the maintenance of seeding during the Plant Establishment Period shall be paid upon Seeding Acceptance as specified in Section 75.02 Landscaping, except as noted below.

If Contractor did not perform maintenance in accordance with Article 4.4 – Maintenance, the remaining 30% shall not be paid.

If damaged seeded areas or areas with insufficient coverage are not repaired or replaced as required within fourteen (14) days of written notice, the Engineer may replace or have replaced the damaged items and deduct the cost of said repair or

replacement work from the remaining payments. The cost of said repair or replacement work is based on receipts for replacement seeding, excavation or earthwork as required, and ten percent (10%) administrative markup.

Payment shall be made on the following basis:

ITEM	UNIT
Seeding (Type)	1,000 Square Feet

When more than one type of seeding is specified for any pay item, letter suffixes and all other appropriate information, such as hydraulic biotic soil amendment or erosion control medium, shall be included in the “(Type)” of the bid item in order to differentiate between different types.

DRAFT

SECTION 75.05 SOD

Article 5.1 General

The Work under this Section consists of performing all operations pertaining to furnishing, installing, and maintaining sod.

A. Agency Standards: Nomenclature

All plant materials used shall be true to name and size conforming to the Guideline Specifications to Turfgrass Sodding, Turf Grass Producers International.

B. Submittals

Sod: Provide sales slip or certificate describing original seed blend.

Article 5.2 Materials

A. Sod shall be:

Name	Proportion by Weight
Kentucky Bluegrass:	
Nugget	50-100%
Merion	0-50%

B. Sod shall be deep green in color, free of chlorotic conditions or signs of disease, weeds, or infestation. Sod shall be grown in an area of well-drained, loamy soils.

C. Sod shall be #1 Quality/Premium as described in "Guideline Specifications to Turfgrass Sodding." It shall be grown on cultivated agricultural lands and grown specifically for sod purposes.

Article 5.3 Construction

A. Sod Bed Preparation

After grading of areas has been completed in conformity with the lines and grades shown on the Drawings or as directed by the Engineer, scarify and till to a depth of two inches (2") all areas designated to receive topsoil. All cultivated areas shall be raked or cleared of stones one inch (1") in diameter and larger; all debris or irregularities that might interfere with the placement of sod, or subsequent maintenance shall be removed from the site. The Work shall be approved by the Engineer prior to placement of topsoil.

B. Placement of Topsoil in Sod Areas

Following the grading and cultivation of all areas to receive sod, place a uniform layer of topsoil. Topsoil shall be evenly spread on all designated areas to a finish depth of four inches, plus or minus one-half inch (4" ±1/2") after being lightly rolled with a water-filled roller. Spreading shall not be done when the ground is frozen, excessively wet, or otherwise in a condition detrimental to the Work. The Work shall be accepted by the Engineer prior to continuing other Work.

C. Soil Amendments for Sod Areas

Topsoil shall incorporate fertilizer and lime as necessary to meet topsoil chemical constituents. Contractor shall provide a soil test to verify nutrient deficiencies and soil pH.

D. Sod Placement

1. General

- a. Sod shall be cut no more than twenty-four (24) hours before placement. It shall be stored in a manner that protects sod from moisture loss and from extremes in temperature. Soil shall be kept moist.
- b. Sod shall be cut with sharp blades by mechanized equipment designed for the cutting of sod.

2. Harvest

- a. Within twenty-four (24) hours of harvest, sod shall be mowed to a height of one to one and one-half inches (1" to 1-1/2").
- b. Sod shall be cut so as to leave a full intact root mass. It shall be machine cut with a uniform soil thickness of five-eighths inch, plus or minus one-quarter inch ($5/8" \pm 1/4"$) at the time of cutting. Sod that is dry or without soil firmly attached to roots shall be removed from the project site.
- c. Sod shall be cut in straight lines. Cuts shall be of a width between twelve and twenty-four inches (12" and 24"), with all cuts to be the same width, plus or minus one-half inch ($\pm 1/2"$), regardless of the width chosen. Each roll of sod shall be no shorter than four feet (4').

3. Placement

- a. The ground surface shall be wet before placement of sod, to the extent that soil is damp to a six inch (6") depth.
- b. Existing sod areas adjacent to areas to be installed shall have a clean, straight edge and shall be cut with clean, sharp tools. Existing sod edge shall be cut exactly perpendicular to soil surface.
- c. Sod shall be laid perpendicular to the slope of the ground and anchored as appropriate. Where curves are necessary, the sod shall be cut to provide edges in full contact with adjacent sod. There shall be no gaps between adjacent pieces of sod. No sod pieces shall be less than three feet (3') in length, or as approved by the Engineer.
- d. The first row of sod shall be laid in an even line commencing on lowest portion of slopes with subsequent rows placed parallel to and tightly against each other. Lateral joints shall be staggered to promote more uniform growth and strength. Care shall be exercised to ensure that the

pieces are not stretched or overlapped and that all joints are butted tightly.

4. Finishing

Water the sod immediately after transplanting to prevent drying. As sodding is completed in any one section, the area shall be lightly rolled. The new sod shall then be thoroughly watered to a depth sufficient that the underside of the new sod pad and soil immediately below the pad are thoroughly wet. Contractor is responsible for having adequate water available at the site prior to and during installation.

Article 5.4 Maintenance

Maintenance of sod shall conform to Section 75.02, Article 2.4 - Maintenance.

Article 5.5 Measurement

Sod shall be measured per 1,000 square feet and shall be placed in all areas disturbed by construction, or as directed by the Engineer. The sod bid item shall include all labor and material, including all cultivating, materials, limestone, if required, and fertilizer. Seventy percent (70%) of sod bid item shall be measured as quantity of sod installed as specified. The remaining thirty percent (30%) of sod shall be measured as maintenance performed during the Plant Establishment Period and Landscaping Acceptance in the condition identified in Article 5.4 of this Section. Payment process and exceptions are identified in Article 5.6 below and in Division 10, Section 7.7-Final Payments.

Article 5.6 Basis of Payment

Payment of this Work shall be in accordance with Division 10, Section 10.07-Measurement and Payment, and shall include full payment for all Work described in this Section.

Payment for sod includes payment for maintenance during the Plant Establishment Period. Owner will pay the accepted quantity of sod after the Acceptance of Initial Planting Operations, based on seventy percent (70%) of the Contract unit price for sod. The remaining thirty percent (30%) for the maintenance of sod during the Plant Establishment Period shall be paid upon Landscaping Acceptance except as noted below.

If Contractor did not perform maintenance in accordance with Article 5.4-Maintenance, the remaining thirty percent (30%) shall not be paid.

If damaged sod areas are not repaired or replaced as required within fourteen (14) days of written notice, the Engineer may replace or have replaced the damaged items and deduct the cost of said repair or replacement work from the remaining payments. The cost of said repair or replacement work is based on receipts for replacement sod and ten percent (10%) administrative markup.

Payment shall be made under the following unit:

ITEM	UNIT
Sod	1,000 S.F.

SECTION 75.06 LANDSCAPE EDGING

Article 6.1 General

The Work under this Section consists of all labor, equipment, and materials necessary to furnish and install landscape edging. All Work shall be in accordance with these Specifications and shall be placed at the locations shown on the Drawings.

A. Submittals

1. Product information

Article 6.2 Materials

Landscape edging shall be "Curv-Rite, Inc.," black, aluminum, one-eighth inch (1/8") thickness by four inch (4") depth with twelve inch (12") standard aluminum stakes. Comparable products by other manufacturers will be considered for approval by the Engineer provided complete supporting data from the manufacturer is submitted to the Engineer prior to procurement. Comparable products must be architecturally similar in size, type, and grading of materials, dimensions, finishes, and textures.

Curv-Rite, Inc.

3603 North Main Street

Wayland, MI 49348

Article 6.3 Construction

Landscape edging shall be installed per manufacturer's specifications, in all locations shown on Drawings.

Article 6.4 Measurement

Landscape edging shall be measured per linear foot, delivered and accepted in place.

Article 6.5 Basis of Payment

Payment for this Work shall be in accordance with Division 10, Section 10.07 - Measurement and Payment, and shall include full payment for all Work described in this Section.

Payment shall be made under the following unit:

ITEM

Landscape Edging

UNIT

Linear Foot

SECTION 75.07 LANDSCAPE FABRIC

Article 7.1 General

The Work under this Section consists of all labor, equipment, and materials necessary to furnish and install landscape fabric. All Work shall be in accordance with these Specifications and shall be placed at the locations shown on the Drawings.

A. Submittals

- 1. Product information

Article 7.2 Materials

Landscape fabric shall be UV resistant, black polypropylene polyester blend with a permeability minimum of 12 gals/s.f./min. Landscape fabric shall be DeWitt Pro 5 Weed Barrier (1-800-888-9669) or equal approved by the Engineer prior to procurement.

Article 7.3 Construction

Landscape fabric shall be installed per manufacturer’s specifications as called out on Drawings. Landscape fabric shall not be visible under mulch and all loose ends shall be cut off, tucked under, or otherwise covered with mulch by the Contractor. Landscape fabric shall be in direct contact with soil.

Article 7.4 Measurement

Landscape fabric shall be measured per square yard, delivered and accepted in place.

Article 7.5 Basis of Payment

Payment for this Work shall be in accordance with Division 10, Section 10.07 - Measurement and Payment, and shall include full payment for all Work described in this Section.

Payment shall be made under the following unit:

ITEM	UNIT
Landscape Fabric	Square Yard

SECTION 75.08 WILLOW STAKING

Article 8.1 General

The Work under this Section consists of providing all operations pertaining to the gathering, planting and establishing willow vegetation using willow stakes.

For additional reference, see the document "Stream Bank Revegetation and Protection – A Guide for Alaska Revised 2005" published by the Alaska Department of Fish & Game.

- A. Submittals
 - 1. Maintenance Schedule

Article 8.2 Materials

Feltleaf Willow cuttings shall be used and no substitutions shall be accepted without the written permission of the Engineer. Contractor shall be responsible for obtaining dormant cuttings and necessary permits for the collection of willow stakes.

The technique for using dormant cuttings relies on cuttings of stems taken from plants in the wild during late winter and requires proper storage and care of the cuttings between the time of collection and the time of planting.

Dormant cuttings are live stakes taken in the late winter or early spring before buds have opened. Live stakes should be ten to eighteen inches (10" to 18") long and one-half to one and one-half inches (1/2" to 1.5") in diameter, with visible buds. Place cuttings in plastic and keep frozen or refrigerated until the site is ready to plant. Stakes must not be allowed to dry out, nor should they be kept too moist. If cold storage facilities are not available, cuttings can be stored in a snowbank along the north side of a building or some other location that will remain cold until planting. Cuttings may be taken directly from storage to the site for planting. Plant in early spring, after the ground has thawed, and no later than July 1.

Article 8.3 Construction

A. Planting

To plant the cuttings, stick a shovel or three-quarter inch (3/4") or less rebar into the ground as far vertically as possible, push the shovel forward and place the cutting right side up in the ground behind the shovel so that at least three-fourths (3/4) of the length will be buried. Leave a maximum of two leaf buds exposed above ground. Remove the planting implement and step lightly around the cutting to firm the soil. Create a small depression around the planting to collect water.

Willow stakes shall be planted as vertically as possible.

B. Spacing

Dormant cuttings shall be planted one to three feet (1' to 3') on center unless otherwise shown on the Drawings.

C. Watering

Thoroughly water each plant immediately following planting to remove air pockets and increase contact between the soil and the stake. Under no condition shall

plants not be watered in the same day as planting. The Contractor shall maintain moist soil conditions for four to six (4 to 6) weeks to establish plants. Water shall be supplied by the Contractor unless otherwise specified. The Contractor shall assume full responsibility for plant failure as a direct result of insufficient watering.

D. Inspection

The Engineer shall make periodic inspections during the installation and maintenance periods of the Work. Should plant materials, installation procedures, or other conditions be observed not in keeping with the Drawings, details, and these Specifications, the Engineer will direct the Contractor to correct by repair, and/or replacement, as appropriate. The Engineer shall be the sole judge of the conditions of quality and acceptability and will direct all corrections in writing to the Contractor. All rejected materials shall be immediately removed from the site and replaced with specified materials at no additional cost to the Owner.

E. Time of Planting

Spring planting and maintenance shall not begin before May 1, and planting operations may commence as soon as the ground is frost free. Planting and maintenance shall not occur later than July 1, unless otherwise specified or approved in writing by the Engineer.

Article 8.4 Maintenance

A. General

The Contractor shall furnish all labor, materials, supplies and equipment required to establish, maintain, and protect the planted areas, for the Plant Establishment Period from date of acceptance of the initial planting operations. However, maintenance activities shall commence immediately after each item is planted.

The maintenance period shall consist of the time from initial planting through acceptance after the Plant Establishment Period.

The Contractor shall supply a maintenance schedule to the Engineer, thirty (30) days prior to the landscape inspection. The Contractor shall also be responsible for protection of his work during the maintenance period, and shall repair and replace all materials damaged or destroyed within the scope of the Work, regardless of cause.

Contractor shall replace any willow stake damaged during maintenance at no additional cost to the Owner.

B. Watering

A proposed watering schedule shall be submitted to the Engineer thirty (30) days prior to installation of plant materials. The Contractor shall deep water all planted areas, providing water penetration throughout the root zone.

The Contractor shall maintain soil around willow stakes in a moist condition during the maintenance period. Watering shall cease at first hard frost in the fall and shall resume upon ground thaw in the spring.

If at any time during the maintenance period, weather conditions (such as

extended period with no rain or continuous drying winds) cause the plant root zone to dry out, the Engineer may direct the Contractor to deep water all plantings. Any supplemental watering is to be done immediately and at no additional cost to the Owner.

Water application shall be applied at a rate that will provide moisture penetration throughout the entire root zone with a minimum of water run-off. Should soil conditions be encountered not conducive to water absorption, the Contractor shall take whatever corrective actions that may be required to correct this condition, without additional cost to the Owner. If the Contractor does not provide adequate watering as required by the Engineer, the Engineer will hire others to perform this task and deduct costs from final payment to the Contractor.

C. Plant Repair and Replacement

The Contractor shall repair/replace damaged plant materials, regardless of cause, upon notification by the Engineer. Should repair of plant materials reduce their acceptance to less than minimum specified conditions, the Contractor shall replace plants with specified plant replacements at no additional cost to the Owner.

D. Inspection

The Engineer shall make periodic maintenance inspections of the Work. All deficiencies noted shall be corrected within five (5) calendar days from written notice to do so, at no additional cost to the Owner.

Article 8.5 Landscaping Willow Staking Acceptance

A Willow Staking Acceptance Inspection of the project will occur after completion of the Plant Establishment Period. Engineer shall verify that Contractor performed maintenance functions as identified in Article 8.4 – Maintenance of this Section. Additional conditions governing final acceptance of the planted areas are that, in the opinion of the Engineer, all willow stake areas are in a live, uniform, and sound and healthy and flourishing condition; free of disease, insect infestation and physical damage, and free of weeds, rubbish and construction debris. If the Engineer does not accept the improvements, the Contractor shall correct all deficiencies. All costs associated with correcting the deficiencies and extending the Plant Establishment Period shall be paid by the Contractor without additional cost to the Owner.

Should required corrections not be made within thirty (30) days after the initial Final Maintenance Acceptance Inspection, the Contractor shall be assessed liquidated damages per Division 10, Section 10.05, Article 5.27 – Liquidated Damages, until all Work is complete and accepted by the Engineer.

Article 8.6 Measurement

Seventy percent (70%) of each bid item shall be measured as quantity of plants by square yard as specified.

The remaining thirty percent (30%) of each bid item shall be measured as maintenance Work performed during the Plant Establishment Period and the acceptance of the improvements in the condition identified in Article 8.5 of this Section. Payment process and exceptions are identified in Article 8.7 below and in Division 10, Section 7.7 – Final Payments.

Article 8.7 Basis of Payment

Payment for this Work shall be in accordance with Division 10, Section 10.07 - Measurement and Payment, and shall include full payment for all Work described in this Section.

Payment for all willow plantings includes payment for the Plant Establishment Period. Owner will pay the accepted quantity of willow stakes after they are acceptably planted, based on seventy percent (70%) of the Contract unit price for the respective pay items.

The remaining thirty percent (30%) for the maintenance during the Plant Establishment Period shall be paid per Section 75.02 Landscaping, except as noted below.

If Contractor did not perform maintenance in accordance with Article 8.4 – Maintenance, the remaining 30% shall not be paid.

If damaged willows are not repaired or replaced as required within fourteen (14) days of written notice, the Engineer may replace or have replaced the damaged items and deduct the cost of said repair or replacement work from the remaining payments. The cost of said repair or replacement work is based on receipts for replacement cuttings plus ten percent (10%) administrative markup. Replacement by the Owner of any plantings within the last sixty (60) days of the Plant Establishment Period shall trigger a sixty (60) day extension of the Plant Establishment Period.

Payment shall be made on the following basis.

ITEM	UNIT
Willow Staking	Square Yard

SECTION 75.09 SITE FURNISHINGS

Article 9.1 General

Work under this Section consists of providing all operations pertaining to the removal, disposal, relocation, pickup, delivery, assembly, and installation of Owner-supplied Transit or Park site furnishings, including the labor, equipment, and materials. Work may include relocation of bus stop signs, removal and/or installation of bus shelters, trash receptacles, bear-proof trash cans, benches, poop stations, playground equipment, picnic tables, and other transit, park, or urban street furnishings.

A. Submittals

1. Product Data

Article 9.2 Materials

Contractor shall provide installation materials including, but not limited to, concrete footings, anchor bolts, and any other mounting hardware required for the complete installation of the site furnishings. Cost for installation materials is incidental to this pay item.

The Contractor is solely responsible for loading, transporting, unpacking, and assembly of site furnishings.

A. Transit Materials

Transit-related materials for benches, trash receptacles, and bus shelters shall be furnished by the Owner and shall be the type shown on the Drawings. The Contractor shall contact Anchorage Transit System to pick-up materials. The Contractor shall notify Transit Staff within forty-eight (48) hours in the event parts are missing.

B. Park Furnishings

Owner supplied park furnishings shall be the type shown on the Drawings. The Contractor shall contact Anchorage Parks and Recreation to pickup materials.

Park furnishings not Owner supplied must be consistent with current park standards. Contractor shall contact Anchorage Parks and Recreation for specific standards per location.

Article 9.3 Construction

Contractor shall load and transport the owner-supplied site furnishings to the site. Contractor shall assemble and install materials in accordance with the Drawings and the manufacturer's specifications.

Contractor shall be responsible for protection of his work during transportation and installation, and shall repair and replace all furnishings damaged or destroyed within the scope of the Work, regardless of cause.

Article 9.4 Method of Measurement

Method of measurement for the removal and disposal of existing bus shelters and trash receptacles is for each unit.

Method of measurement for the installation of the Owner-supplied furnishings is for each unit complete in place.

Method of measurement for the removal and relocation of the bus stop sign is for unit relocated and complete in place.

Article 9.5 Basis of Payment

Payment for this Work shall be in accordance with Division 10, Section 10.07 - Measurement and Payment, and shall include full payment for all Work described in this Section.

Payment shall be made under the following unit:

ITEM	UNIT
Install Owner-supplied Furnishing (Type)	Each
Remove and Relocate Bus Sign	Each
Remove Furnishing (Type)	Each

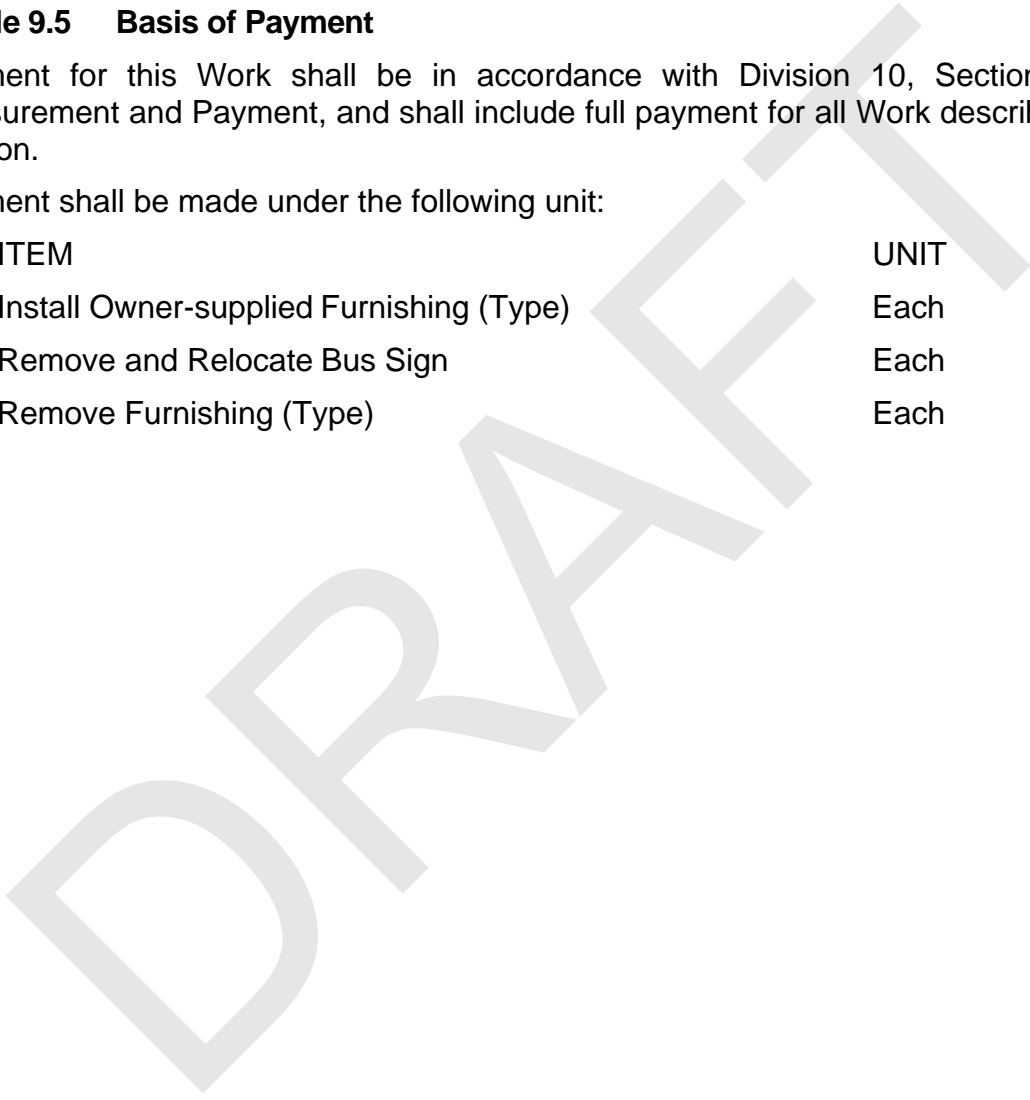

SECTION 75.10 BOLLARDS

Article 10.1 General

The Work under this Section consists of all labor, equipment, and materials necessary to complete the construction of wood, concrete pipe, and removable steel bollards as shown on the Drawings. Where existing bollards are removed prior to reuse, Contractor shall erect "hasty" fence or snow fence to deter vandalism by motorized vehicles.

The following Applicable Standards shall be used:

AMERICAN SOCIETY FOR TESTING AND MATERIALS (ASTM)

ASTM A 36M	(1997a) Carbon Structural Steel
ASTM A 123	(1989a) Zinc (Hot-Dipped Galvanized) Coatings on Iron and Steel Products
ASTM A 307	Standard Specification for Carbon Steel Bolts, Studs, and Threaded Rods of 60000 PSI Tensile Strength in Sized from ¼ inch to 4 inches in Diameter
ASTM A 500	(1996) Cold-Formed Welded and Seamless Carbon Steel Structural Tubing in Rounds and Shapes
ASTM A 501	Standard Specification for Hot-Formed Welded and Seamless Carbon Steel Structural Tubing
ASTM A 615/A 615M	Standard Specification for Deformed and Plain Billet-Steel Bars for Concrete Reinforcement
ASTM C 150	Portland Cement

American Wood Protection Association (AWPA) AWPA P5 Standards of Waterborne Preservatives

West Coast Lumber Inspection Bureau standard grading and dressing rules

Western Wood Products Association standard grading and dressing rules.

Article 10.2 Materials

A. Wood Bollards

1. Storage and Protection: Protect lumber from weather. Store inside whenever possible.
2. Grading Rules: Standard grading and dressing rules of the West Coast Lumber Inspection Bureau or the Western Wood Products Association. Each piece of yard and structural lumber shall bear official grade mark of the appropriate bureau or association. Provide Common No. 1 or better Hem/Fir wood, surfaced four (4) sides unless otherwise noted on the Drawings, and kiln dried. Moisture content shall not exceed nineteen percent (19%).
3. Preservative Pressure Treatment

- a. Pressure-treat all wood in direct contact with ground with chromate copper arsenate, Type II (AWPA P-5) with a retention of 0.45 lbs. per cubic foot of wood. Contractor shall submit a certificate of treatment to the Engineer for approval prior to use on the Project.
 - b. After treatment, wood shall be clean, of natural color and finish, non-corrosive, water repellent, paintable, odorless, dry, and non-staining.
 - c. Cut Wood bollards to length necessary for construction before preservative pressure treatment is applied.
4. Paint: Stain Wood bollards with two coats Color Shield '4000' Alkyd Flat stain, or approved equal. Color to be Russet Brown, or similar. Apply stain to clean dry surface, free of dust or dirt, in accordance with the manufacturer's recommendations and specifications.

B. Concrete Pipe Bollards

Contractor shall use only new products in construction and installation of concrete pipe bollards. Standard products of a manufacturer regularly engaged in the manufacture of such products. The materials provided shall be of a type with proven satisfactory use for at least two years.

1. Concrete
Portland cement shall conform to ASTM C 150 Types I, II, or III.
2. Finish
Finish shall be galvanized. Exposed surfaces and edges shall be rounded, polished, or sanded. Finish shall be non-toxic, non-glare, and resistant to corrosion
3. Galvanizing
After fabrication, hot-dip galvanized components in zinc in accordance with ASTM A 123. Remove Tailings and sharp protrusions formed as a result of the hot-dip process and burnish exposed edges.
4. Tubing
Provide Schedule 40 steel tubing of the size specified in the Drawings.
5. Paint
Prime Tubing and cover with two coats minimum of dark green powder coat paint in accordance with the manufacturer's instructions. Top coat with two coats Yellow Carboline 139, unless guard post cover or sleeve is to be installed.

C. Removable Steel Bollards

Furnish hardware as necessary and as detailed for the project. Items include bolts, nuts, anchor bolts, washers, nuts, and rods (ASTM A-307). Hot-dip galvanize all bolts, nuts, washers, and plates in accordance with ASTM A-123.

Provide steel that conforms with ASTM A-36 structural carbon steel, shop fabricated and galvanized.

Painting: Etch galvanized surface with "Galvaprep."

D. Guard Post Cover/Sleeve

Provide guard post covers molded from a durable polyethylene with ultra-violet (UV) stabilizers to ensure product life and color fastness.

Secure the polyethylene guard post cover or sleeve in accordance with the manufacturer's recommendations. Provide Carsonite SAV-T Sleeve, the guard post cover or sleeve, or approved equal.

Article 10.3 Construction

A. Acceptance of Existing Surfaces

The Contractor shall verify that finished grade and other operations affecting mounting surfaces have been completed prior to the installation of bollards. Install Bollards plumb and true in accordance with the approved manufacturer's instructions or recommendations.

B. Installation

For concrete pipe bollard, provide footing as shown on Drawings. Slope drainage from tubing at two percent (2%) grade. Place concrete inside steel pipe or tubing for full extent. Rod concrete to remove air voids. Dome top to provide clean transition from top surface to bollard sides. Do not leave exposed edge. Provide brushed finish to concrete dome.

Install bollards plumb, level and true to line. Top of a row of bollards shall be maintained at a consistent level above adjacent ground.

C. Removable Bollards

Install bollard base plate flush with top of paved trail. Install bollards plumb, level, and true to line. Use only three-sixteenth inch (3/16") fillet welds. Grind all edges smooth.

Fasteners: Padlocks for removable bollards shall be American Padlock, 2 inch shackle that accepts the interchangeable or IC best core purchased. Cores shall be keyed to Municipality Of Anchorage cores matched to a 645 key. Installation of the cores must be authorized by Facilities Management at 907-343-8270 or email FacilitiesManagementWorkRequests@anchorageak.gov. Padlocks are incidental to this pay item.

D. Clean Up

Clean the site of all materials associated with the installation. Clean surfaces of dirt, stains, filings, and other blemishes occurring from shipment and installation. Provide cleaning methods and agents according to manufacturer's instructions or as indicated. Remove excess concrete.

Article 10.4 Method of Measurement

Measurement will be based on complete units in place for all bollards.

Measurement for concrete pipe bollard with sleeve shall be for a concrete pipe bollard with polyethylene guard post cover or sleeve installed in place.

Measurement for "Remove Bollard" shall be for each bollard removed and disposed of as directed on the Drawings. Footings, anchoring devices, and other items shown on the Drawings shall be considered incidental to the bid item "Removable Bollard" and no separate payment shall be made.

Any other items required for a complete and finished installation shown on the Drawings are measured separately for payment purposes.

Article 10.5 Basis of Payment

Payment for this Work shall be in accordance with Division 10, Section 10.07 - Measurement and Payment, and shall include full payment for all Work described in this Section.

Payment shall be made under the following unit:

ITEM	UNIT
Bollard (Type) (Color as appropriate)	Each
Remove Bollard	Each
Remove & Reset Bollard	Each

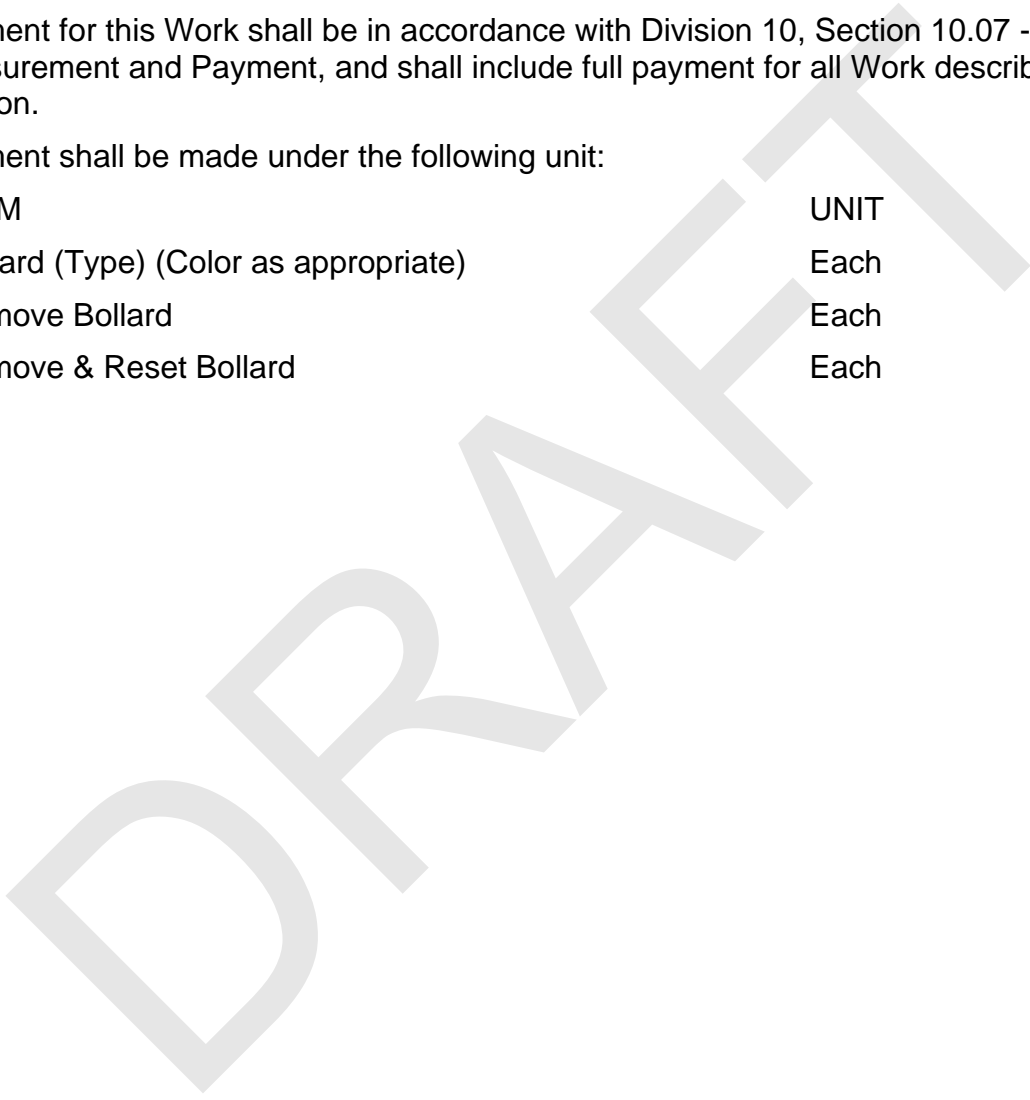

SECTION 75.11 MODULAR CONCRETE BLOCK WALL

Article 11.1 Description

Work under this Section consists of furnishing all labor, equipment, and materials to complete the construction of a modular concrete block wall and steps. Accomplish all work as shown on the Drawings and as described herein.

A. Submittals

1. Product Data

Article 11.2 Materials

Wall units shall be eight inch (8") Allan Block Retaining Wall System or equal approved by the Engineer prior to procurement. Capstones and corner blocks are required.

Color: Grey
Size: 8"H x 12"D x 18L
Style: AB Classic

All materials required for proper installation of the retaining wall system, including specified backfill, are incidental to this Section.

Article 11.3 Manufacturer and Local Representative

Manufacturer:	Local Representative:
Allan Block Corporation	Anchorage Sand and Gravel Co., Inc.
7400 Metro Boulevard, Suite 185	1040 O'Malley Road
Edina, MN 55439	Anchorage, AK 99515
800-835-5309	907-348-6300
952-835-0013 (fax)	907-349-3967 (fax)

Article 11.4 Construction

Contractor shall install wall in accordance with manufacturer's specifications and as shown on Drawings. Contractor shall install wall to match the geometric layout shown on Drawings, including corners. Any changes in the layout require Engineer's approval. Contractor shall ensure the tops of wall elevations are continuous.

Contractor shall secure capstone with Type P1 Premium Water Proof Construction adhesive per the manufacturer's specifications.

Article 11.5 Method of Measurement

Measurement is the area in square feet based on the above-grade vertical face of complete units in place. Blocks, specified backfill or other items shown on the Drawings, are not measured separately for payment and are incidental to this bid item.

Article 11.6 Basis of Payment

Payment for this Work shall be in accordance with Division 10, Section 10.07 – Measurement and Payment, and shall include full payment for all Work described in this Section.

Payment shall be made under the following unit:

ITEM	UNIT
Modular Concrete Block Wall	Square Foot

DRAFT

SECTION 75.12 BOULDERS

Article 12.1 General

Work under this Section includes furnishing the labor, equipment, and materials necessary for the furnishing and placing of Contractor-supplied boulders.

A. Submittals

1. Product Photos and Source data

Article 12.2 Materials

Contractor shall furnish boulders similar in appearance, color, type, and approximate size as shown on Drawings or specified in the Contract Documents. No evidence of drilling, scrapes, large flakes, or cracks shall be visible after the boulder is set in place.

Article 12.3 Construction

The Contractor shall coordinate with the Engineer prior to setting boulders to ensure desired face and orientation is achieved. Boulders shall be placed on site as directed by the Engineer.

The Contractor shall form a pocket for boulder installation, ensuring that the boulder is even and true to line, buried one-third to one-half ($1/3$ to $1/2$) of the boulder depth, and in accordance with the Standard Detail, or as shown on the Drawings.

Article 12.4 Method of Measurement

Boulders will be measured as units of the specified size complete in place.

Article 12.5 Basis of Payment

Payment for this Work shall be in accordance with Division 10, Section 10.07 – Measurement and Payment, and shall include full payment for all Work described in this Section.

Payment shall be made under the following unit:

ITEM	UNIT
Boulder (Size)	Each

SECTION 75.13 ROOT PRUNING

Article 13.1 General

Work under this Section includes but is not limited to all equipment, labor, and transportation necessary to provide root pruning as shown on the Drawings and specified herein. Root Pruning is required where all work abuts mature tree plantings that are to remain in place.

- A. Submittals
 - 1. Tree Service Firm Qualifications
 - 2. Arborist Qualifications

Article 13.2 Materials

Burlap: A strong woven fabric made of jute, hemp, or flax fibers.

Article 13.3 Quality Assurance

- A. Tree Service Firm Qualifications: The Contractor shall furnish the Engineer with firm qualifications for approval. The firm shall be an experienced tree service firm that has successfully completed tree protection and trimming work similar to that required for this Project and that will assign an experienced, qualified arborist to the project site during execution of tree protection, trimming, and root pruning.
- B. Arborist Qualifications: The Contractor shall furnish the Engineer with arborists certifications or licenses. The arborist shall be certified by ISA or licensed in the jurisdiction where the Project is located.

Article 13.4 Construction

- A. Workmanship and Procedure
 - 1. Root Pruning shall be performed when below ground construction occurs within 16 feet of a mature tree. Mature trees are trees that are 4" diameter at breast height (DBH) or greater in size. Root Pruning shall be done to a depth of 18 inches. The distance to prune away from the base of a tree shall be determined by providing 1 foot of horizontal distance from the trunk of the tree for every 1 inch of DBH of that tree.
 - 2. All roots 1" in diameter or greater shall be cut clean with a root pruner, a sharp saw, and/or hand pruners.
 - 3. Roots must not be pruned or removed from more than one side of a tree.
 - 4. All pruned roots are to be covered by wet burlap and kept moist for the duration of time that the root is exposed.
 - 5. Topsoil shall be used to backfill the excavated area around the root.
- B. Maintenance
 - 1. Keep the burlap that is covering pruned roots moist for the duration of time that the root is exposed.

Article 13.5 Measurement

Measurement for Root Pruning shall be by the linear foot.

Article 13.6 Basis of Payment

Payment for this Work shall be in accordance with Division 10, Section 10.07 – Measurement and Payment, and shall include full payment for all Work described in this Section.

Payment shall be made under the following unit:

ITEM

Root Pruning

UNIT

Linear Foot

DRAFT

SECTION 75.14 TREE PROTECTION ZONE FENCE

Article 14.1 General

Work under this Section includes all equipment, labor, and transportation necessary to furnish, install, and remove Tree Protection Zone Fences as specified herein. Tree Protection Zone Fences are required where all work abuts mature tree plantings that are to remain in place. Tree Protection Zone Fences are to be removed when construction is complete.

Tree Protection Zone (TPZ): Tree Protection Zones shall be per Section 75.02

A. Submittals

1. Product Data

Article 14.2 Submittals

Certification: Provide a certification from a certified arborist that trees indicated to remain have been protected during construction according to recognized standards and that trees were promptly and properly treated and repaired when damaged.

Maintenance Recommendations: Provide a copy of recommendations, from a certified arborist, for care and protection of trees affected by construction during and after completing the Work.

Article 14.3 Quality Assurance

- A. Tree Service Firm Qualifications:** The Contractor shall furnish the Engineer with firm qualifications for approval. The firm shall be an experienced tree service firm that has successfully completed tree protection and trimming work similar to that required for this Project and that will assign an experienced, qualified arborist to the project site during execution of tree protection, trimming, and root pruning.
- B. Arborist Qualifications:** The Contractor shall furnish the Engineer with arborists certifications or licenses. The arborist shall be certified by ISA or licensed in the jurisdiction where the Project is located.
- C. Tree Pruning Standards:** Comply with ANSI A300 (Part 1), "Tree, Shrub, and Other Woody Plant Maintenance – Standard Practices (Pruning)."
- D. Pre-installation Conference:** Before tree protection operations begin, meet with the Engineer, Arborist to review tree protection procedures and responsibilities and determine tree protection fencing limits on site.
- E. Prior to any excavation, tree protection limits will be staked by the Contractor and approved by the Engineer.**
- F. Provide written acceptance from a certified arborist that trees indicated to remain and protected by Tree Protection Zones have been protected during construction according to recognized standards and that trees were promptly and properly treated and repaired when damaged.**

SECTION 75.15 MOOSE PROTECTION FENCE

Article 15.1 General

Work under this Section includes all equipment, labor, and transportation necessary to furnish, install, and remove Moose Protection Fence as specified herein. Moose Protection Fence is required around all new individual deciduous trees and/or deciduous tree groupings. Moose Protection Fences are to be removed at the completion of the plant establishment period, unless otherwise directed by the Engineer. The Engineer may notify the Contractor about damages to the Moose Protection Fence, in which case the repairs shall be made within two (2) working days. The Contractor shall repair and replace all materials damaged or destroyed within the scope of the Work, regardless of cause.

A. Submittals

1. Product Data

Article 15.2 Materials

- A. Fabric: 1"x2" welded wire mesh. Min. 14-gauge wire diameter.
- B. Steel T-Posts: 10' height, green steel T-posts with pointing.

Article 15.3 Construction

Workmanship and Procedure: Moose protection fence shall be erected immediately following the tree installation. The moose protection fence shall be placed at the outside edges of individual deciduous trees and/or deciduous tree groupings. All deciduous trees shall be enclosed within the fence without damaging branches or allowing branches to protrude. The fence shall remain in place during the duration of the Work and shall be removed at the end of the maintenance period.

Article 15.4 Measurement

Measurement for Moose Protection Fence shall be by the linear foot.

Article 15.5 Basis of Payment

Payment for this Work shall be in accordance with Division 10, Section 10.07 – Measurement and Payment, and shall include full payment for all Work described in this Section.

Payment shall be made under the following unit:

ITEM

Moose Protection Fence

UNIT

Linear Foot

Section 75.16 RESET FENCE

Article 16.1 General

The Work under this Section consists of providing all operations pertaining to removing, storing, and resetting existing fence whatever height and type of fencing material as indicated on the Drawings or as directed by the Engineer.

Article 16.2 Material

All materials which can be reused shall be salvaged from the existing fence. Those materials which cannot be salvaged or are damaged by the Contractor's operations shall be replaced, at the Contractor's expense, with new materials which as nearly as possible duplicate the kind and quality of materials in the original installation.

Nails, staples, fastening wires or devices, and all materials required for the construction of such anchors, end posts or other portions of the fence which can be replaced more efficiently than they can be moved, shall be furnished by the Contractor.

If the property owner elects to replace any of the existing fencing materials with other materials in better condition, they shall furnish and deliver such materials to the site of the Work, upon the approval of the Engineer and the Contractor.

Article 16.3 Construction

The fence shall be set in close conformity with the property line shown on the Drawings or as directed by the Engineer. Posts and anchors shall be set at the same depth and spacing as in the original fence. Wire shall be drawn taut but care shall be taken to avoid over-stressing the salvaged materials. Permanent anchors, end posts or other parts which cannot be economically moved shall be replaced by equivalent construction. If any new materials require painting, they shall be painted to match the original materials as nearly as possible. If a match cannot be attained to the satisfaction of the Engineer, the entire fence will be painted. The reset fence shall be placed in at least as good condition as the existing fence before it was moved.

Article 16.4 Measurement

Resetting fence will be measured by length in linear feet, complete and accepted in its final position.

Article 16.5 Basis of Payment

Payment for this Work shall be in accordance with Division 10, Section 10.07 - Measurement and Payment, and shall include full payment for all Work described in this Section.

Payment shall be made under the following unit:

ITEM	UNIT
Remove and Reset Fence	Linear Foot
Reset Fence	Linear Foot

SECTION 75.17 CHAIN LINK FENCE

Article 17.1 General

The Work under this Section consists of providing all materials and operations pertaining to construction of chain link fencing.

A. Applicable Standards:

The following applicable standards shall be used:

ASTM A641	Zinc-Coated (Galvanized) Carbon Steel Wire
ASTM A53	Pipe, Steel, Black and Hot Dipped Zinc Coated Welded and Seamless
ASTM A121	Metallic-Coated Carbon Steel Barbed Wire
ASTM A123/AASHTO M111	Zinc (Hot-Dipped Galvanized) Coatings on Iron and Steel Products
ASTM A153/AASHTO M232	Zinc Coating (Hot Dip) on Iron and Steel Hardware
ASTM A227	Steel Wire, Cold-Drawn for Mechanical Springs
ASTM A307	Carbon Steel Bolts, Studs, and Threaded Rod 60,000 PSI Tensile Strength

Article 17.2 Materials

Material used in the construction of chain link fencing shall be in accordance with the Standard Details and the requirements of the Chain Link Fence Manufacturers Institute, as described below.

A. General

Posts, gate frames, braces, rails, stretcher bars, and truss rods shall be of steel; reinforcing wires shall be of high carbon steel; and gate hinges, post caps, barbed-wire supporting arms, stretcher bar bands, and other parts shall be of steel, malleable iron or equal except that ties and clips may be of aluminum.

Contractor shall form parts accurately to dimensions. All steel and iron parts shall be zinc coated after fabrication, using zinc grade "E" in accordance with Federal Specifications QQ-Z-351.

The weight of the zinc coating per square foot of actual surface shall average not less than 1.2 ounces and no individual specimen shall weigh less than 1.0 ounce. Zinc-coated surfaces shall be free from imperfectly coated spots, bruised or scaled coating, drops of zinc, sharp projections, and sal ammoniac spots.

Posts, gate frames, rails, and braces shall conform to the dimensions and weights shown in the Dimensions and Weights Table in Article 18.3 – Tables.

B. Fabric

Fencing fabric shall be zinc coated by the hot-dip process after fabrication. The zinc coating shall be commercially uniform. It shall not have less than 1.2 ounces per square foot when tested. Fabric gauge shall be as shown in the Fencing Fabric Size Table in Article 18.3 - Tables.

C. Gates

Gates shall be swing or sliding, single or double, as specified, complete with latches, stops, keepers, hinges, or rollers and roller tracks, and, when so specified, with provisions for three (3) strands of barbed wire above the fabric.

Gate frames shall be constructed of tubular members and shall be constructed in a manner such as to provide a rigid frame and ample strength and shall be free from sag and twist. Where a barbed wire top is specified, the end members of gate frames shall be extended approximately one foot (1') above the top member and arranged for attaching three (3) uniformly spaced strands of barbed wire and furnished with bands or other suitable method for securely attaching the wire. Fabric shall be attached securely to the gate frame at intervals not to exceed fifteen inches (15").

Hinges shall be of heavy pattern, of adequate strength for the gate, and with large bearing surfaces for clamping them in position. The hinges shall not twist or turn under the action of the gate. The gates shall be capable of being opened and closed easily by one person.

Latches, stops and keepers shall be provided for all gates. Latches shall have the plunger-bar arranged to engage the gate stop, except that for single gates with openings less than ten feet (10') wide, a forked latch may be provided. Latches shall be arranged for locking. Center stops shall consist of a device arranged to be set in concrete and to engage the plunger of the bar latch of double gates. No stop is required for single gates. Keepers shall consist of a mechanical device for securing the free end of the gate when in the full open position.

D. Posts

Posts shall be of the lengths specified and shall be tubular, except that line posts may be H-beam. Dimension and weight shall conform to the Dimensions and Weights Table in Article 18.3 – Tables, unless otherwise specified.

E. Post Braces

Post braces shall be provided for each gate, corner, pull, and end post for use with fabric five feet (5') or more in height, and shall consist of a round tubular brace extending to each adjacent post at mid-height of the fabric, and a truss consisting of a rod not less than three-eighths inch (3/8") in nominal diameter from the adjacent post back to the gate, corner, pull, or end post, with a turnbuckle or other equivalent provision for adjustment.

F. Post Tops

Post tops shall consist of ornamental tops or combination tops and barbed-wire

supporting arms, as specified. When so specified or when a top rail is to be provided, the top shall be provided with a hole suitable for the through passage of the top rail. The post tops shall fit over the outside of the posts and shall exclude moisture from the tubular posts.

G. Barbed-Wire Supporting Arms

Barbed-wire supporting arms, when specified to be furnished, shall be at an angle of approximately forty-five degrees (45°) and shall be fitted with clips or other means for attached three lines of barbed-wire. The top outside wire shall be approximately twelve inches (12") horizontally from the fence line and the other wires spaced uniformly between the top of the fence fabric and the outside barbed wire.

H. Top Rails

Top rails shall be round (tubular), shall be in lengths not less than eighteen feet (18'), and shall be fitted with couplings for connecting the lengths into a continuous run. The coupling shall be not less than six inches (6") long, shall provide a substantial connection, and shall allow for expansion and contraction of the rail. Suitable ties or clips shall be provided in sufficient number for attaching the fabric securely to the top rail at intervals not exceeding two feet (2'). Means shall be provided for attaching the top rail to each gate, corner, pull, and end post.

H. Stretcher Bars

Stretcher bars shall not be less than three-sixteenth inch by three-quarter inch (3/16" x 3/4") and shall be of lengths one inch (1") less than the full height of the fabric with which they are to be used. The stretcher bars shall be arranged for attaching the fabric to all terminal posts by threading through the fabric, by bands, or by other positive mechanical means.

J. Ties or Clips

Ties or clips of adequate strength shall be provided for attaching the fabric to lineposts.

K. Fabric Bands

Fabric bands of adequate strength shall be provided for attaching the fabric and stretcher bars to all terminal posts.

L. Tension Wires

A bottom tension wire shall be provided unless otherwise specified. Top tension wire shall be provided, when so specified, in lieu of a top rail. The tension wires shall be of coiled spring wire not less than seven (7) gage plus or minus 0.005 inch in diameter. Ties or clips shall be provided for attaching each wire to the fabric at intervals not exceeding two feet (2').

M. Barbed Wire

Barbed wire shall consist of two (2) strands of twelve and one-half (12.5) gauge wire with fourteen (14) gauge four (4) point barbs spaced approximately five

inches (5") apart. All wire shall be zinc coated with a minimum coating of 0.80 ounces per square foot of surface area on twelve and one-half (12.5) gauge wire.

N. Vinyl Clad Fencing

Those components specified to be vinyl-clad or coated shall have a vinyl covering ten to fourteen (10-14) mils in thickness. Fabric is to be nine (9) gauge wire. Products are to be Colorbond II as manufactured by Colorguard Corporation, or approved equal.

Article 17.3 Tables

DIMENSIONS AND WEIGHTS

Use and Section		Nominal Outside Diameter Dims (Inches)	Nominal Weight per Foot, (Pounds)
Tubular End, Corner, and Pull Posts for:			
fabric height: 6 feet and less	Round	2.375	3.65
fabric height: over 6 feet	Round	2.875	5.79
Rails and Post Braces	Round	1.66	2.27
Intermediate Posts for:			
fabric height: 6 feet and less			
Tubular	Round	1.90	2.72
C-Section		1.875 x 1.625	2.28
fabric height: over 6 feet			
Tubular	Round	2.375	3.65
C-Section		2.25 x 1.70	2.64
Gate Posts with Fabric Over 6 Feet for Gate Leaf Widths:			
leaf width: 6 feet and less	Round	2.875	4.64
leaf width: over 6 to 13 feet	Round	4.000	8.65
leaf width: over 13 to 18 feet	Round	6.625	18.02
leaf width: over 18 to 24 feet	Round	8.625	27.12
Gate Frame Members for:			
fabric height: Less than 6 feet	Round	1.66	1.83
fabric height: 6 feet and over	Round	1.90	2.28
Interior Bracing:	Round	1.66	1.83

FENCING FABRIC SIZE

Recommended Usage	Height of Fabric	Mesh Size	Gauge	Nominal Diameter Coated Wire (Inches)
Heavy Industrial	36" through 144"	2"	6	0.192
Industrial/Residential	36" through 144"	2"	9	0.148
Light Industrial/Residential	36" through 84"	2"	11	0.120
Tennis Court	120" through 144"	1-3/4"	11	0.120

Article 17.4 Construction

A. Grading

All trees, brush and other obstacles which would interfere with the construction of the fence shall be removed and disposed of at a Contractor-provided disposal area and shall be considered incidental to the Contract. The fence shall follow a smooth profile. Throughout the fence length the distance between the ground surface and the bottom tension wire shall not be greater than four inches (4"), nor less than two inches (2"). Where excavation is necessary to meet this requirement, the ground will be graded level not less than one foot (1') on either side of the fence and backslopes of one and one-half to one (1½:1) provided. Where backfill is necessary to meet this requirement, natural surface vegetation will be removed prior to placing fill material. The top of the fill shall be level for one foot (1') on either side of the fence line and the shoulder slopes shall be one-half foot to one foot gradient (½':1'). Grading for all specific conditions shall be such that water will not be allowed to pond in the immediate area of the fence. Where drainage is required across the fence line, the Engineer shall be consulted and channels provided in accordance with his decision.

B. Posts

All posts shall be set in Class B Portland Cement Concrete footings. The tops of the footings shall be level with the ground, shall be crowned to provide drainage and shall be troweled smooth. The dimensions of the footings shall be as shown on the Drawings. The footings shall be allowed to cure for a period of at least seven (7) days before attaching fabric.

The Contractor shall set the posts vertical and of uniform and equal height above the ground with a maximum horizontal spacing of ten feet (10') center. On straight runs, pull posts shall be provided at intervals not to exceed five hundred (500) lineal feet. Changes in line of thirty degrees (30°) or more shall be considered corner posts. Steep slopes and abrupt changes in topography may require changes in various elements of the fence. The chain link fabric shall be stretched taut and securely fastened to end, corner, or gate posts. The top edge of the fabric shall be fastened to the top rail, and the lower edge of the fabric shall be fastened to the bottom tension wire.

C. Fabric

Place fabric on the side specified, stretched taut, and securely fastened to the posts. Fasten fabric to end, gate, corner and pull posts with stretcher bars and fabric bands spaced at intervals of fifteen inches (15") or less. Fastening to line posts shall be with ties or clips at fifteen inch (15") intervals.

Join rolls of wire fabric by weaving a single strand into the ends of the rolls to form a continuous mesh. Horizontal splices are not permitted.

D. Top Rail

Top rails shall pass through the ornamental tops of the line posts, forming a continuous brace from end to end of each stretch of fence. Join lengths of tubular top rail by sleeve couplings. Secure top rails fastened to terminal posts by pressed steel fittings or other appropriate means.

E. Tension Wire

Provide one continuous length of tension wire between pull posts. Apply sufficient tension to avoid excess sag between the posts. Tie or otherwise fasten tension wires to end, gate, corner, or pull posts by methods approved by the Engineer.

F. General Appearance

Runs of fence shall present the same general appearance and the product of one manufacturer only will be accepted, except for items which do not influence the appearance of the completed fence. No used, rerolled, or open-seam steel will be permitted in posts, gate frames, rails or braces.

Article 17.5 Measurement

Chain link fencing will be measured per linear foot, in place, from outside to outside of end or corner posts, except for the space occupied by gates.

Gates will be measured per each, complete in place for a particular size.

Article 17.6 Basis of Payment

Payment for this Work shall be in accordance with Division 10, Section 10.07 - Measurement and Payment, and shall include full payment for all Work described in this Section.

Unit cost payment shall be made on the following basis:

ITEM	UNIT
Chain Link Fence (Include Heights and Gage)	Linear Foot
Gate (Type and Size)	Each

**MUNICIPALITY OF ANCHORAGE
STANDARD SPECIFICATIONS**

**DIVISION 75
LANDSCAPING IMPROVEMENTS
STANDARD DETAILS**

DRAFT

**STANDARD CONSTRUCTION SPECIFICATIONS
DIVISION 75
INDEX OF STANDARD DETAILS**

75-1	Shrub Planting Detail
75-2	Conifer Planting Detail
75-3	Deciduous Tree Planting Detail
75-4	Wood Bollard
75-5	Removable Wood Bollard
75-6	Removable Steel Rectangular Bollard
75-7	Steel Bollard
75-8.1	Removable Circular Bollard (Sheet 1 of 2)
75-8.2	Removable Circular Bollard (Sheet 2 of 2)
75-9	Boulder
75-10	Tree Protection Zone Fence
75-11	Moose Protection Fence
75-12	Fence Details
75-13	Fence Details

REVISION: 11/14 REQUIRED REMOVAL OF BURLAP & ALL WIRE
07/20 ADDED BERM AND CHANGED MULCH DEPTHS

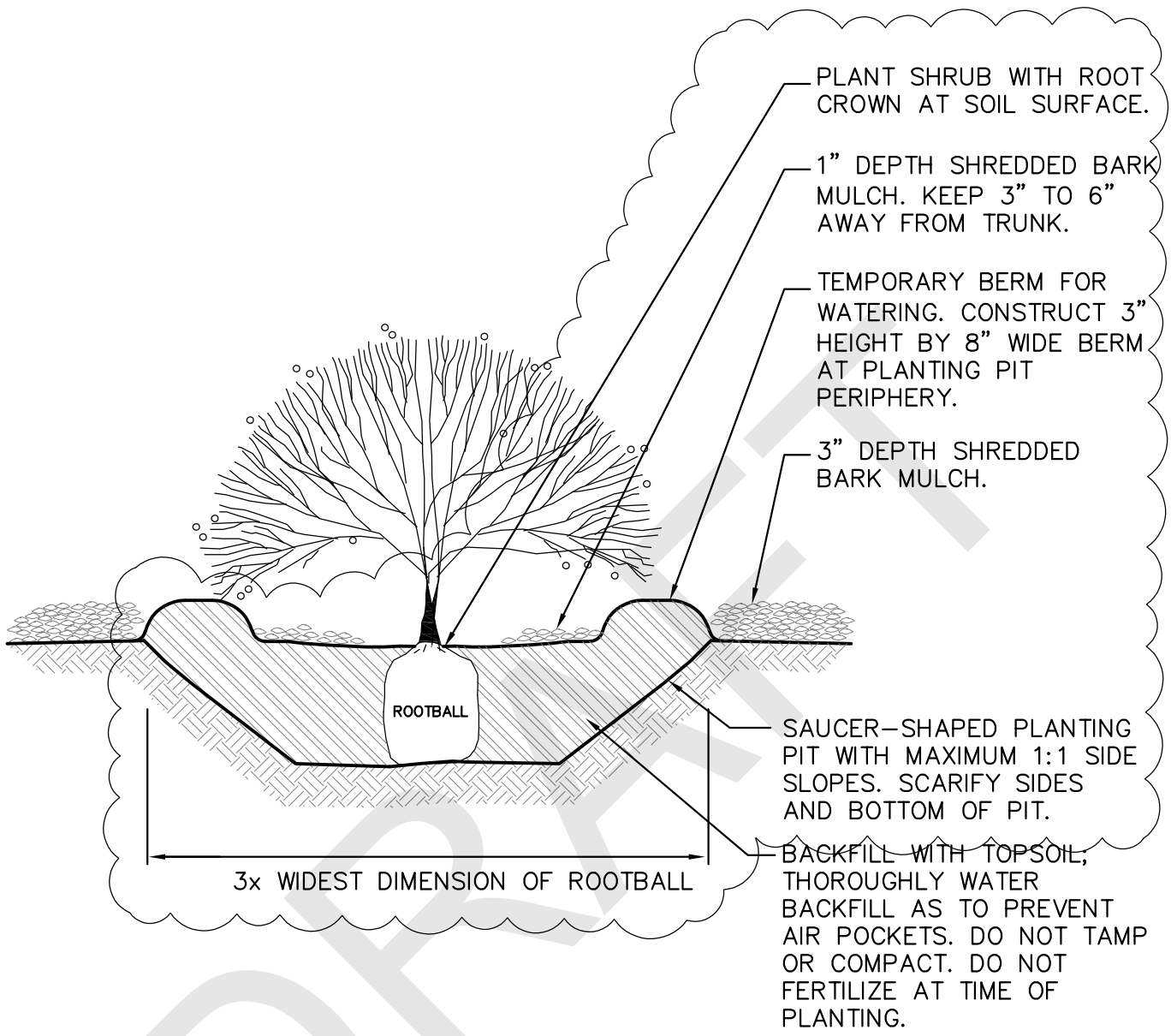

NOTES:

1. DEPTH VARIES DEPENDING ON ROOTBALL THICKNESS.
2. SOIL SHALL BE LOOSENED AND SUITABLE FOR ROOT GROWTH. TOP WIDTH OF PLANT PIT SHALL BE 3 TIMES ROOTBALL DIAMETER.
3. CONTRACTOR SHALL COMPLETELY REMOVE BURLAP, WIRE, WIRE BASKETS, AND CONTAINERS.
4. TEMPORARY BERM SHALL BE REMOVED AT LANDSCAPE ACCEPTANCE AND REPLACED WITH 3" DEPTH SHREDDED BARK MULCH.

<p>MUNICIPALITY  OF ANCHORAGE</p>	<p>SCALE: NTS</p> <p>APPROVED:</p> <p>REVISED: 10/23</p>	<p>SHRUB PLANTING DETAIL</p>	<p>SECTION # 75.02</p> <p>DETAIL # 75-1</p>
--	--	-------------------------------------	---

* STAKE ONLY IF NEEDED TO STABILIZE ROOTBALL. SEE SPECIFICATIONS FOR FURTHER REQUIREMENTS RELATED TO THIS DETAIL.

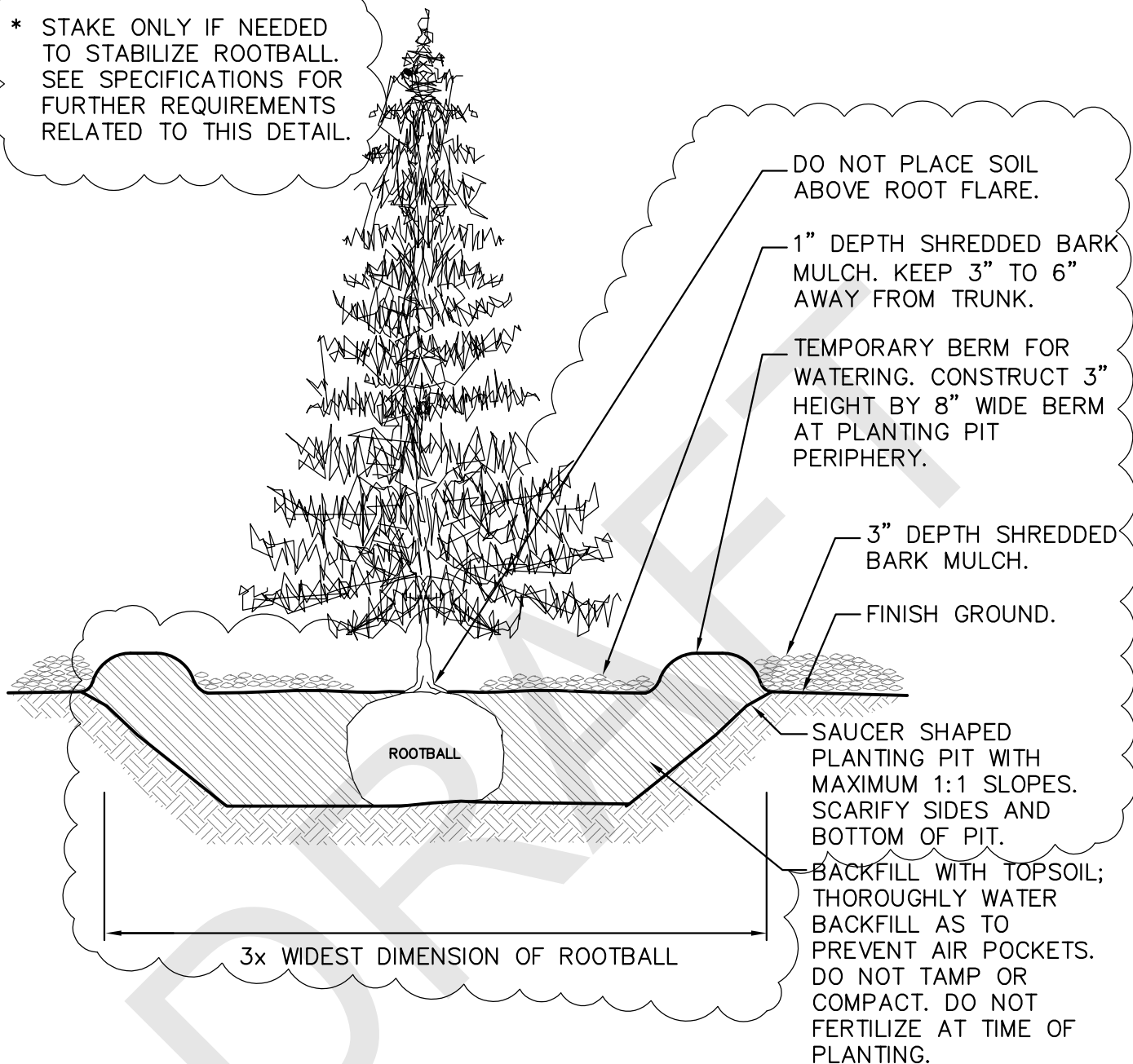

DO NOT PLACE SOIL ABOVE ROOT FLARE.

1" DEPTH SHREDDED BARK MULCH. KEEP 3" TO 6" AWAY FROM TRUNK.

TEMPORARY BERM FOR WATERING. CONSTRUCT 3" HEIGHT BY 8" WIDE BERM AT PLANTING PIT PERIPHERY.

3" DEPTH SHREDDED BARK MULCH.

FINISH GROUND.

SAUCER SHAPED PLANTING PIT WITH MAXIMUM 1:1 SLOPES. SCARIFY SIDES AND BOTTOM OF PIT.

BACKFILL WITH TOPSOIL; THOROUGHLY WATER BACKFILL AS TO PREVENT AIR POCKETS. DO NOT TAMP OR COMPACT. DO NOT FERTILIZE AT TIME OF PLANTING.

3x WIDEST DIMENSION OF ROOTBALL

ROOTBALL

NOTES:

1. DEPTH OF PLANT PIT VARIES DEPENDING ON ROOTBALL THICKNESS.
2. SOIL SHALL BE LOOSENED AND SUITABLE FOR ROOT GROWTH. TOP WIDTH OF PLANT PIT SHALL BE 3 TIMES ROOTBALL DIAMETER. SET ROOTBALL ON SOLID GROUND TO PREVENT SETTLING. PLANT TREE TRUNK WITH TRUNK FLARE AT OR UP TO 1" ABOVE FINISHED GROUND.
3. CONTRACTOR SHALL COMPLETELY REMOVE BURLAP, WIRE, AND WIRE BASKETS.
4. TEMPORARY BERM SHALL BE REMOVED AT LANDSCAPE ACCEPTANCE AND REPLACED WITH 3" DEPTH SHREDDED BARK MULCH.

REVISION: 11/14 REQUIRED REMOVAL OF BURLAP & ALL WIRE 07/20 ADDED BERM AND CHANGED MULCH DEPTHS

<p>MUNICIPALITY</p>  <p>OF ANCHORAGE</p>	<p>SCALE: NTS</p> <p>APPROVED:</p> <p>REVISED: 10/23</p>	<p>CONIFER PLANTING DETAIL</p>	<p>SECTION # 75.02</p> <p>DETAIL # 75-2</p>
---	--	---------------------------------------	---

* STAKE ONLY IF NEEDED TO STABILIZE ROOTBALL. SEE SPECIFICATIONS FOR FURTHER REQUIREMENTS RELATED TO THIS DETAIL.

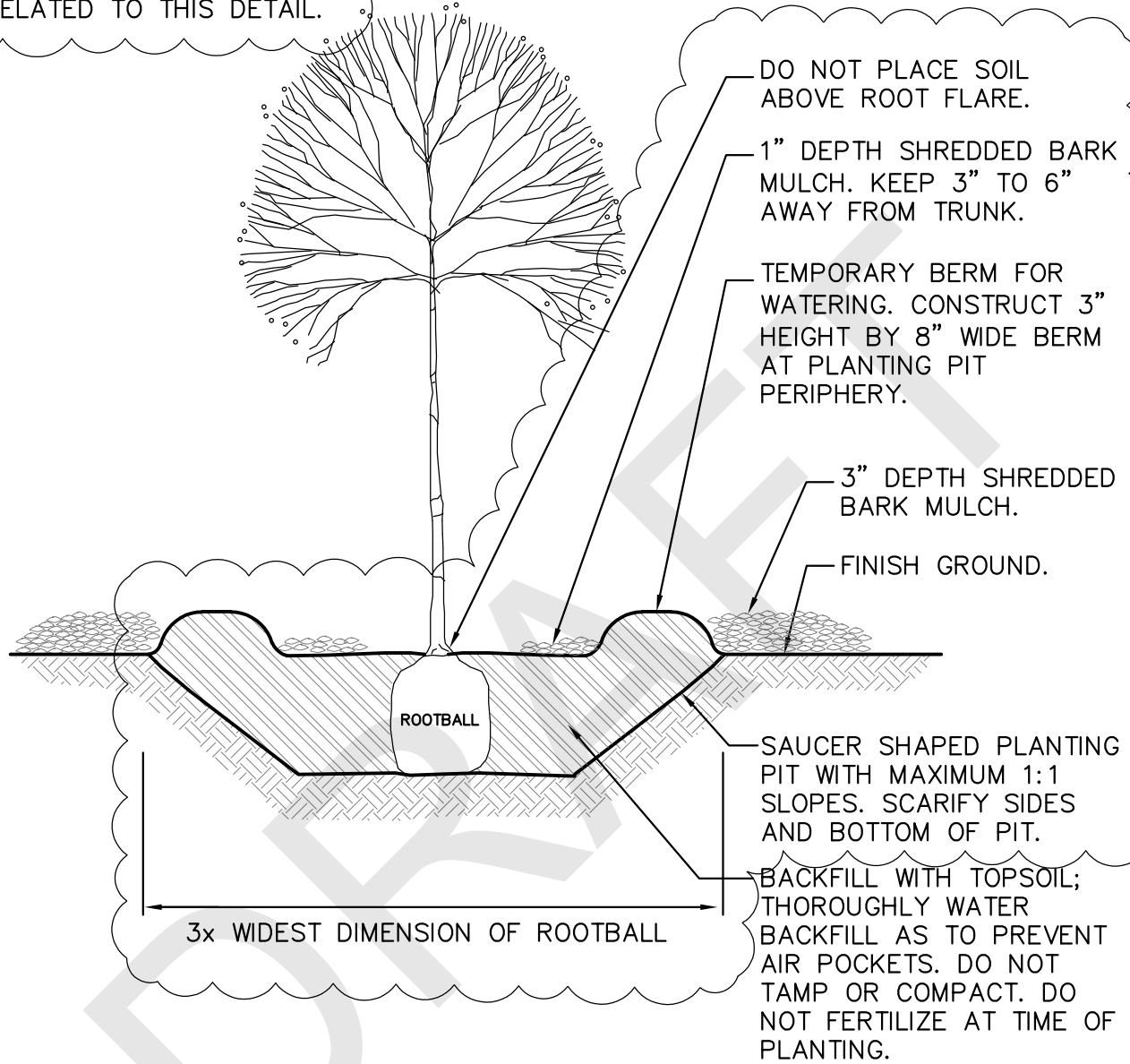

NOTES:

1. DEPTH OF PLANT PIT VARIES DEPENDING ON ROOTBALL THICKNESS.
2. SOIL SHALL BE LOOSENED AND SUITABLE FOR ROOT GROWTH. TOP WIDTH OF PLANT PIT SHALL BE 3 TIMES ROOTBALL DIAMETER. SET ROOTBALL ON SOLID GROUND TO PREVENT SETTLING. PLANT TREE TRUNK WITH TRUNK FLARE AT OR UP TO 1" ABOVE FINISHED GROUND.
3. CONTRACTOR SHALL COMPLETELY REMOVE BURLAP, WIRE, AND WIRE BASKETS.
4. TEMPORARY BERM SHALL BE REMOVED AT LANDSCAPE ACCEPTANCE AND REPLACED WITH 3" DEPTH SHREDDED BARK MULCH.

REVISION: 11/14 REQUIRED REMOVAL OF BURLAP & ALL WIRE
07/20 ADDED BERM AND CHANGED MULCH DEPTHS

MUNICIPALITY



OF ANCHORAGE

SCALE:
NTS

APPROVED:

REVISED:
10/23

DECIDUOUS TREE PLANTING DETAIL

SECTION #
75.02

DETAIL #
75-3

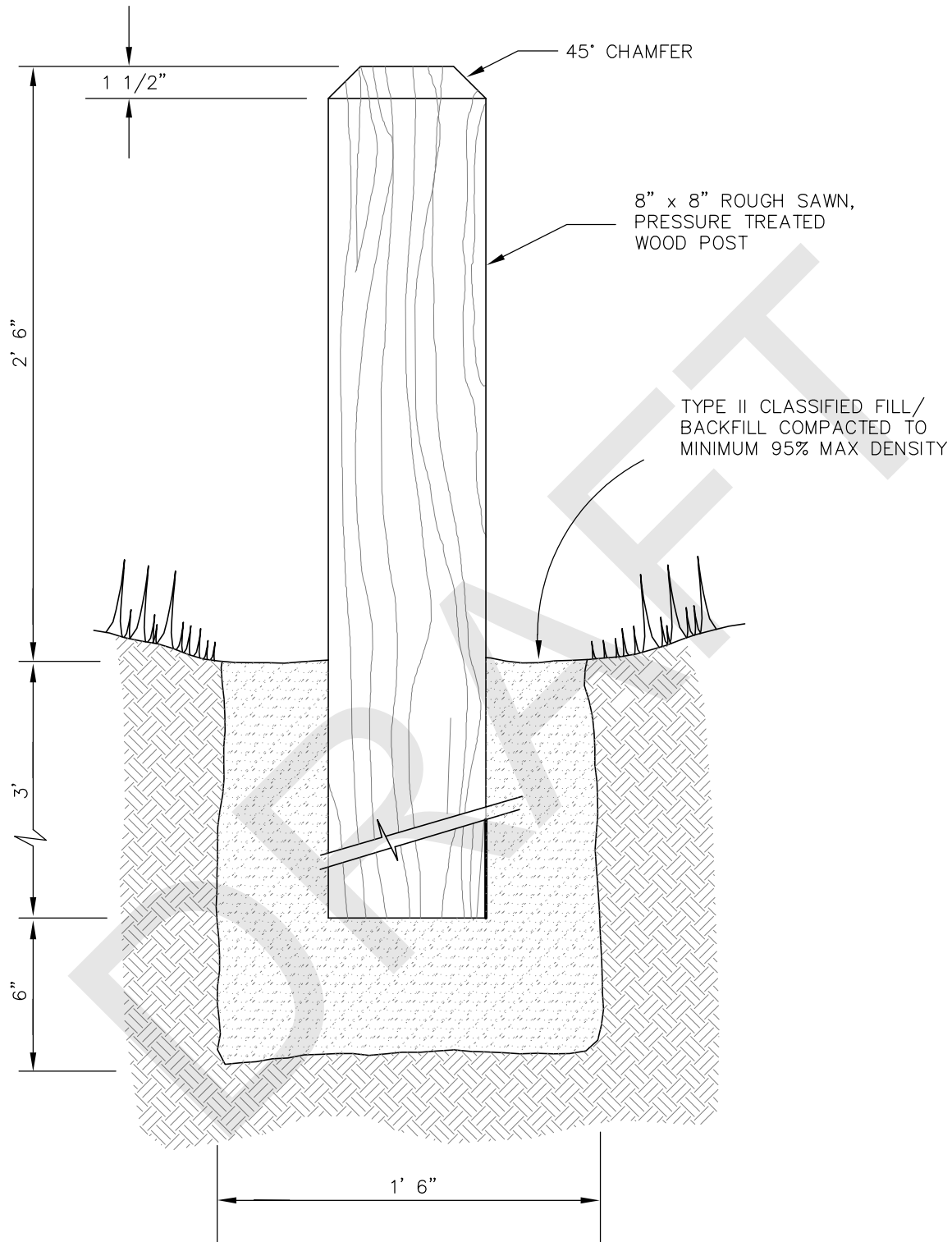

MUNICIPALITY



OF ANCHORAGE

SCALE:
NTS

APPROVED:

REVISED:
10/23

WOOD BOLLARD

SECTION #
75.10

DETAIL #
75-4

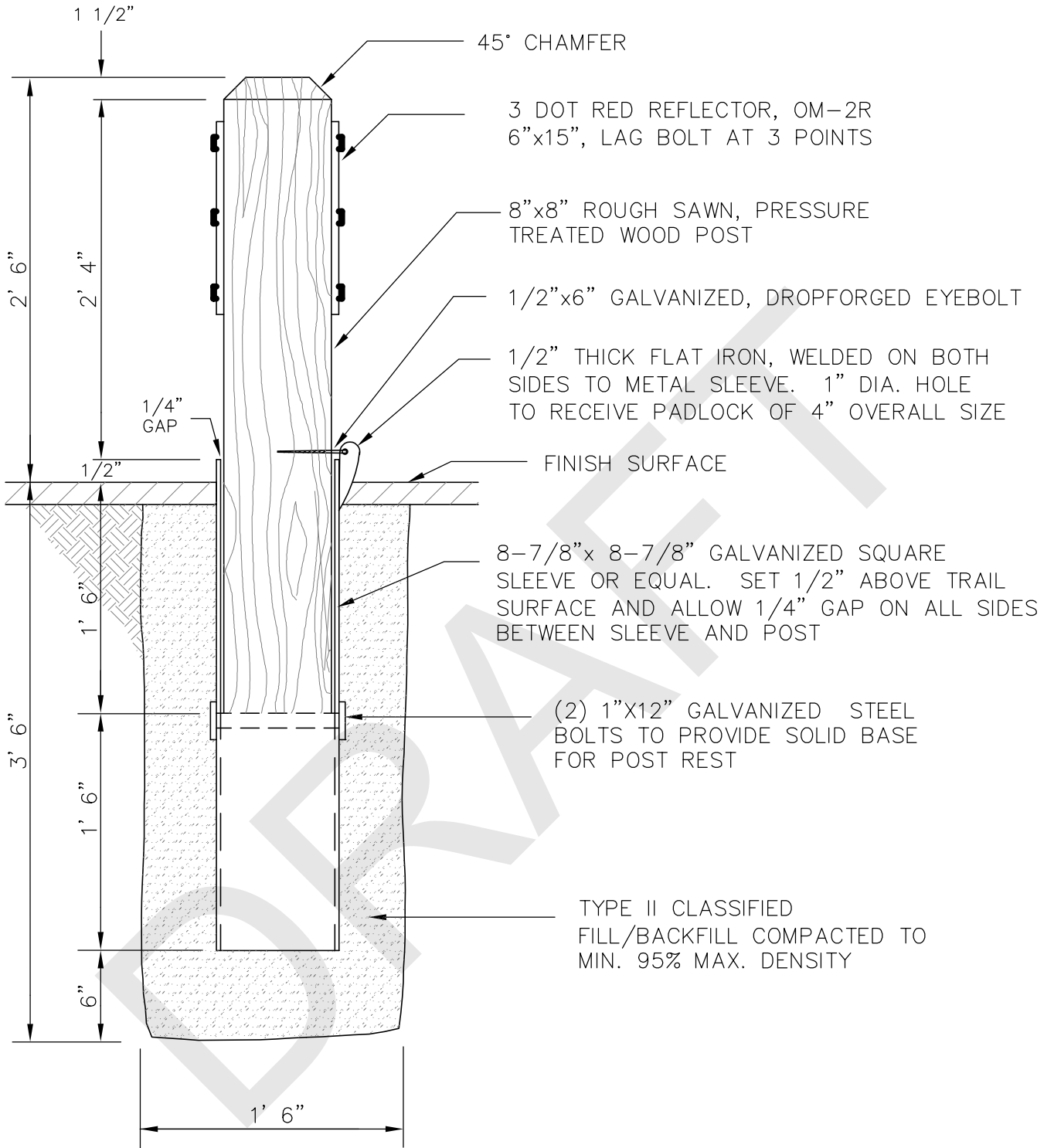

NOTES
 1. LOCATE PADLOCK AWAY FROM TRAFFIC FLOW.

<p>MUNICIPALITY</p>  <p>OF ANCHORAGE</p>	<p>SCALE: NTS</p> <p>APPROVED:</p> <p>REVISED: 10/23</p>	<p>REMOVABLE WOOD BOLLARD</p>	<p>SECTION # 75.10</p> <p>DETAIL # 75-5</p>
---	--	--------------------------------------	---

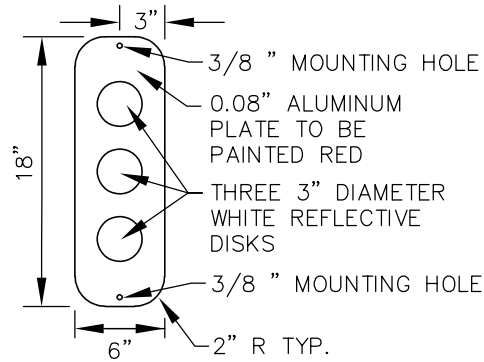

REFLECTOR PLATE

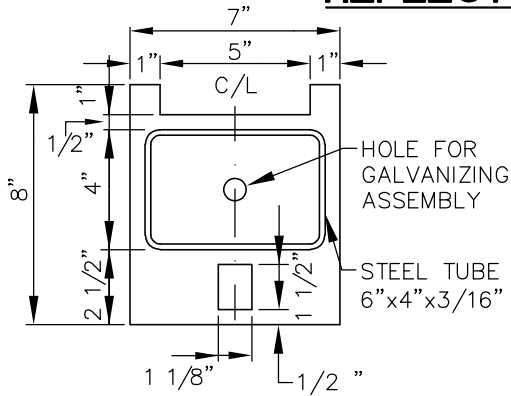

POST BASE PLATE

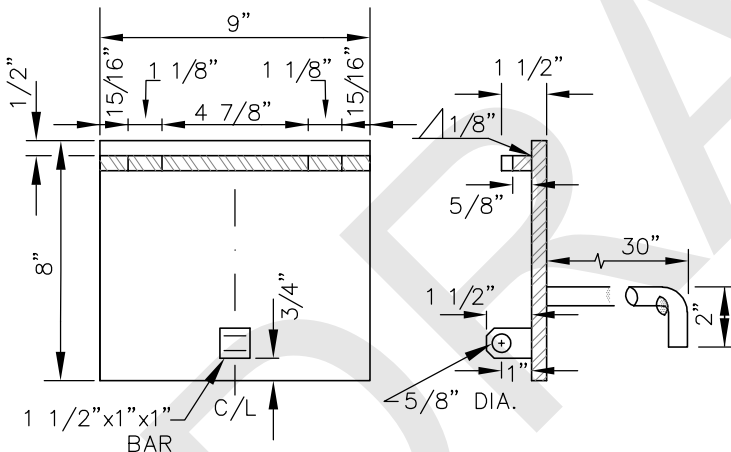
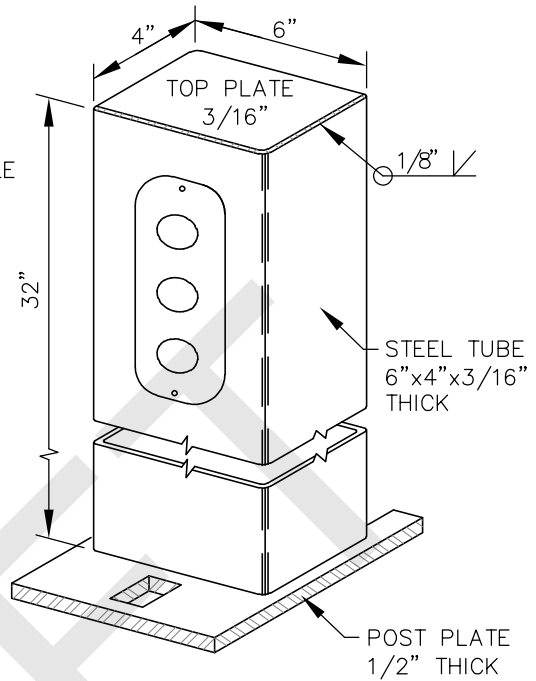

GROUND BASE PLATE

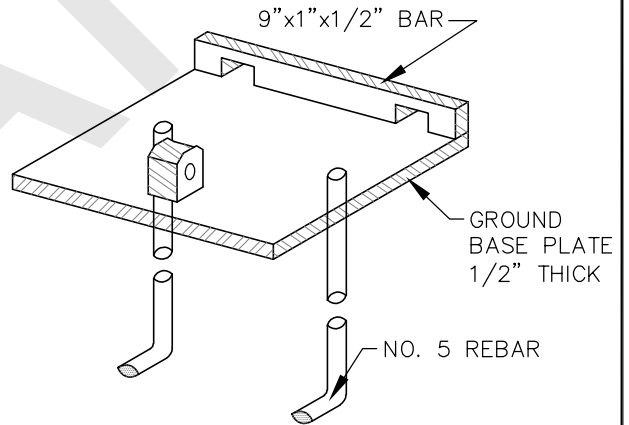

ISOMETRIC VIEW

NOTES:

1. ALL WELDS, UNLESS OTHERWISE SHOWN, SHALL BE THREE-SIXTEENTH INCH (3/16") FILLET – ALL AROUND.
2. CAST IN PLACE WITH CLASS 'A' CONCRETE IN A TWELVE INCH DIAMETER BY THIRTY SIX INCH (12" X 36") FOUNDATION TUBE.
3. REMOVABLE BOLLARDS ARE TO HAVE ADHESIVE REFLECTORS ON BOTH FRONT AND BACK OF POST.
4. ALL EXTERIOR CORNERS AND EDGES SHALL BE ROUNDED TO PROVIDE A PROJECTION FREE SURFACE.

MUNICIPALITY



OF ANCHORAGE

SCALE:
NTS

APPROVED:

REVISED:
10/23

**REMOVABLE BOLLARD
(RECTANGULAR)**

SECTION #
75.10

DETAIL #
75-6

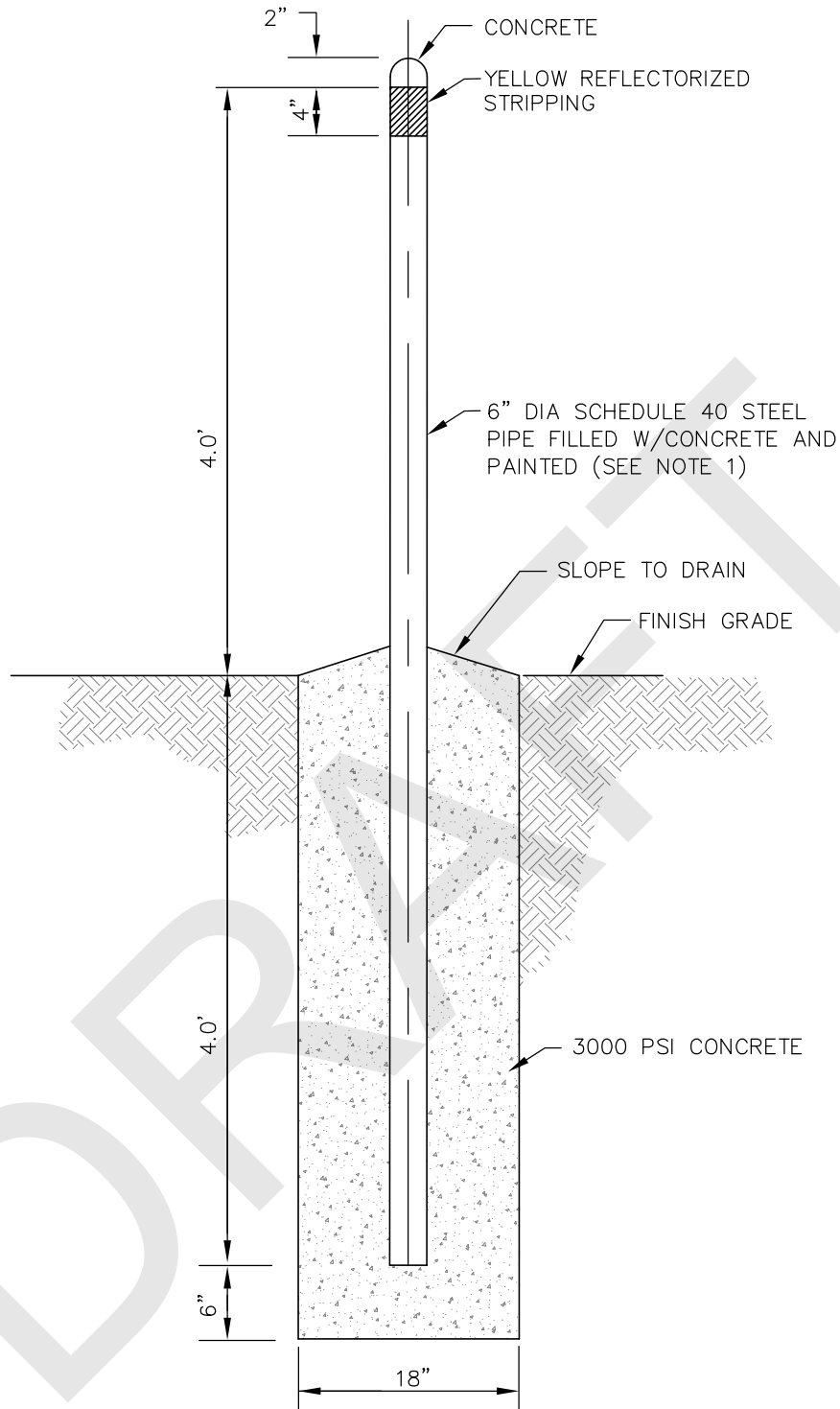

NOTES:

1. POSTS SHALL BE PRIMED AND RECEIVE TWO COATS MINIMUM OF DARK GREEN POWDER COAT PAINT I.A.W. MANUFACTURER'S RECOMMENDATIONS. TOPCOAT WITH TWO COATS YELLOW CARBOLINE 139 UNLESS GUARD POST COVER OR SLEEVE IS INSTALLED.

MUNICIPALITY



OF ANCHORAGE

SCALE:
NTS

APPROVED:

REVISED:
10/23

STEEL BOLLARD

SECTION #
75.10

DETAIL #
75-7

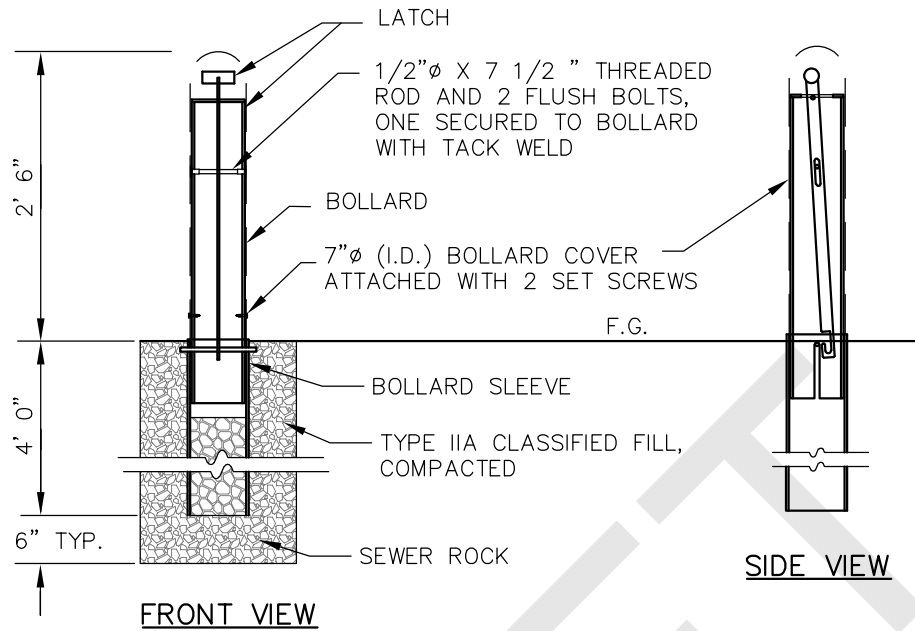

NOTE: ALL FINAL FABRICATIONS TO BE GALVANIZED PRIOR TO ASSEMBLY

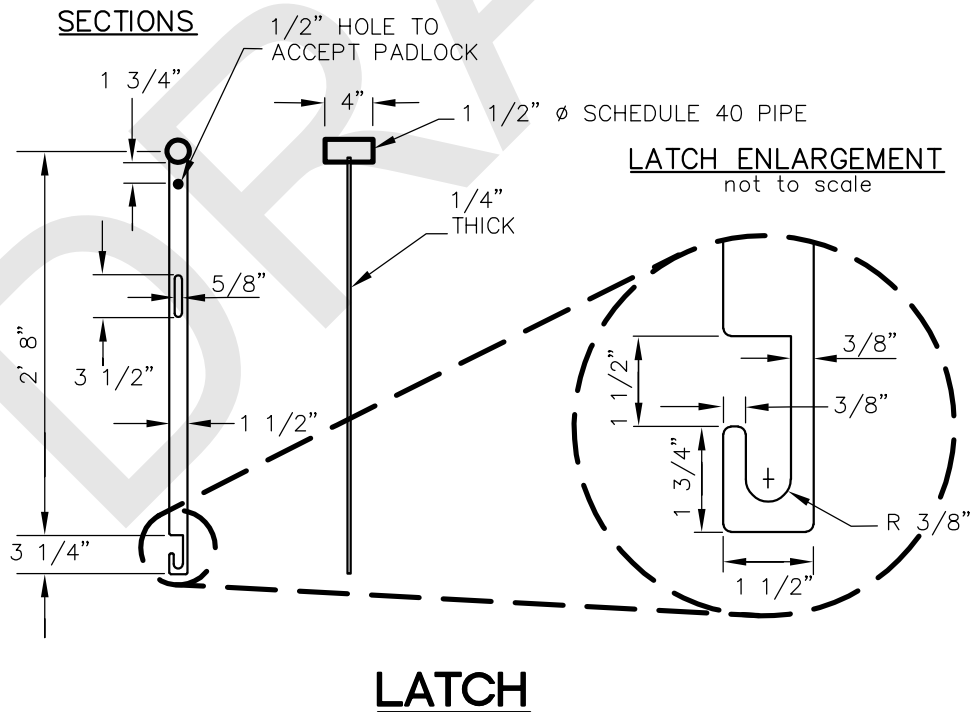

SCALE:
NTS

APPROVED:

REVISED:
10/23

**REMOVABLE BOLLARD
(ROUND)**

SHEET 1 OF 2

SECTION #
75.10

DETAIL #
75-8.1

PLAN VIEW

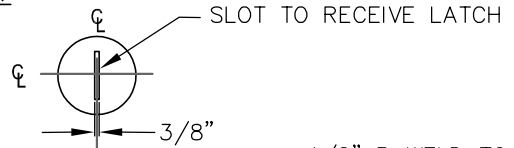

SECTIONS

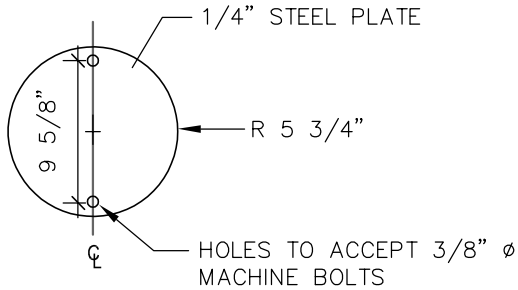
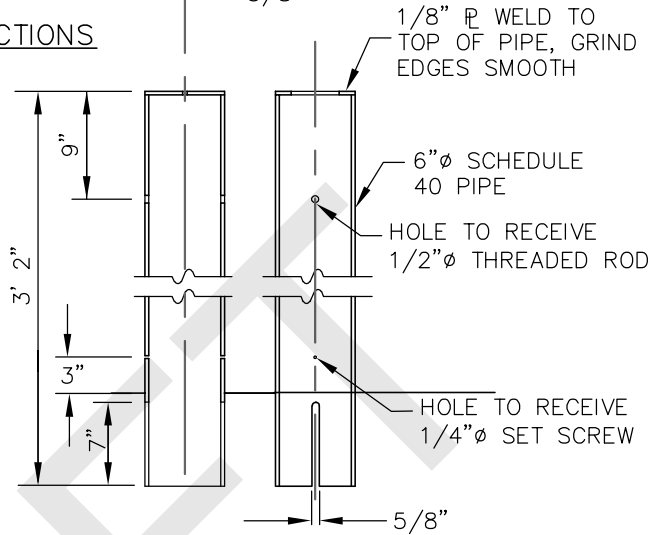

NOTE: PROVIDE 1 TEMPORARY CAP PER REMOVABLE BOLLARD TO OWNER.

**REMOVABLE BOLLARD
TEMPORARY CAP**

BOLLARD

CROSS-SECTION: TOP

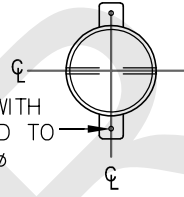

1/8" TBS WITH HOLE THREADED TO ACCEPT 3/8" ϕ MACHINE BOLT

A

CROSS-SECTION: BOTTOM

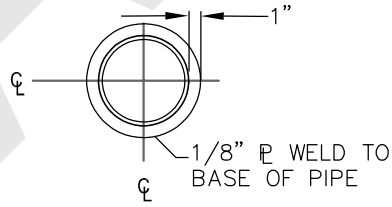

1/8" TBS WELD TO BASE OF PIPE

B

SECTIONS

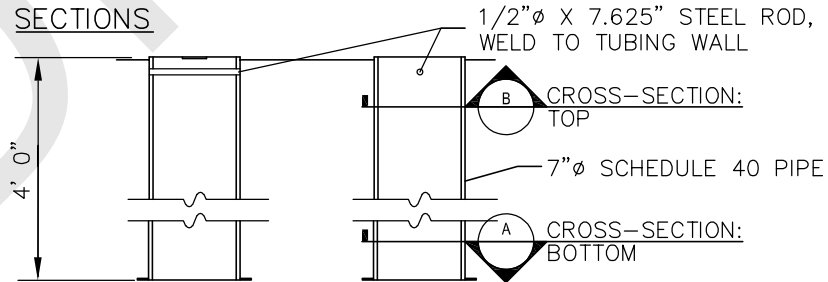

NOTE: SET SLEEVE 1/8" ABOVE ADJACENT SURFACE

BOLLARD SLEEVE

MUNICIPALITY



OF ANCHORAGE

SCALE:
NTS

APPROVED:

REVISED:
10/23

**REMOVABLE BOLLARD
(ROUND)
SHEET 2 OF 2**

SECTION #
75.10

DETAIL #
75-8.2

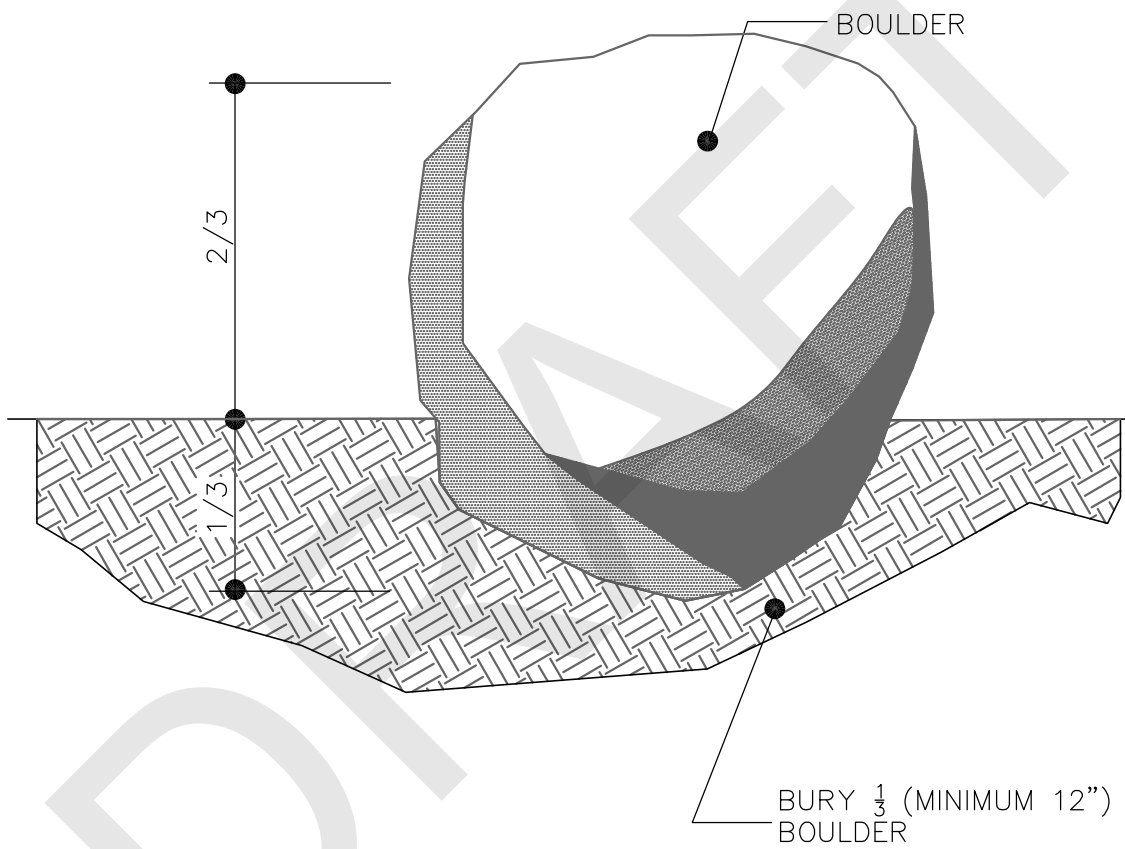

BOULDER

NOTES:

1. ORIENTATION OF BOULDERS DETERMINED ON-SITE BY THE ENGINEER.

MUNICIPALITY



OF ANCHORAGE

SCALE:
NTS

APPROVED:

REVISED:
10/23

BOULDER

SECTION #
75.12

DETAIL #
75-9

PLACE FENCING AT CROWN DRIP LINE,
UNLESS OTHERWISE NOTED IN DRAWINGS.

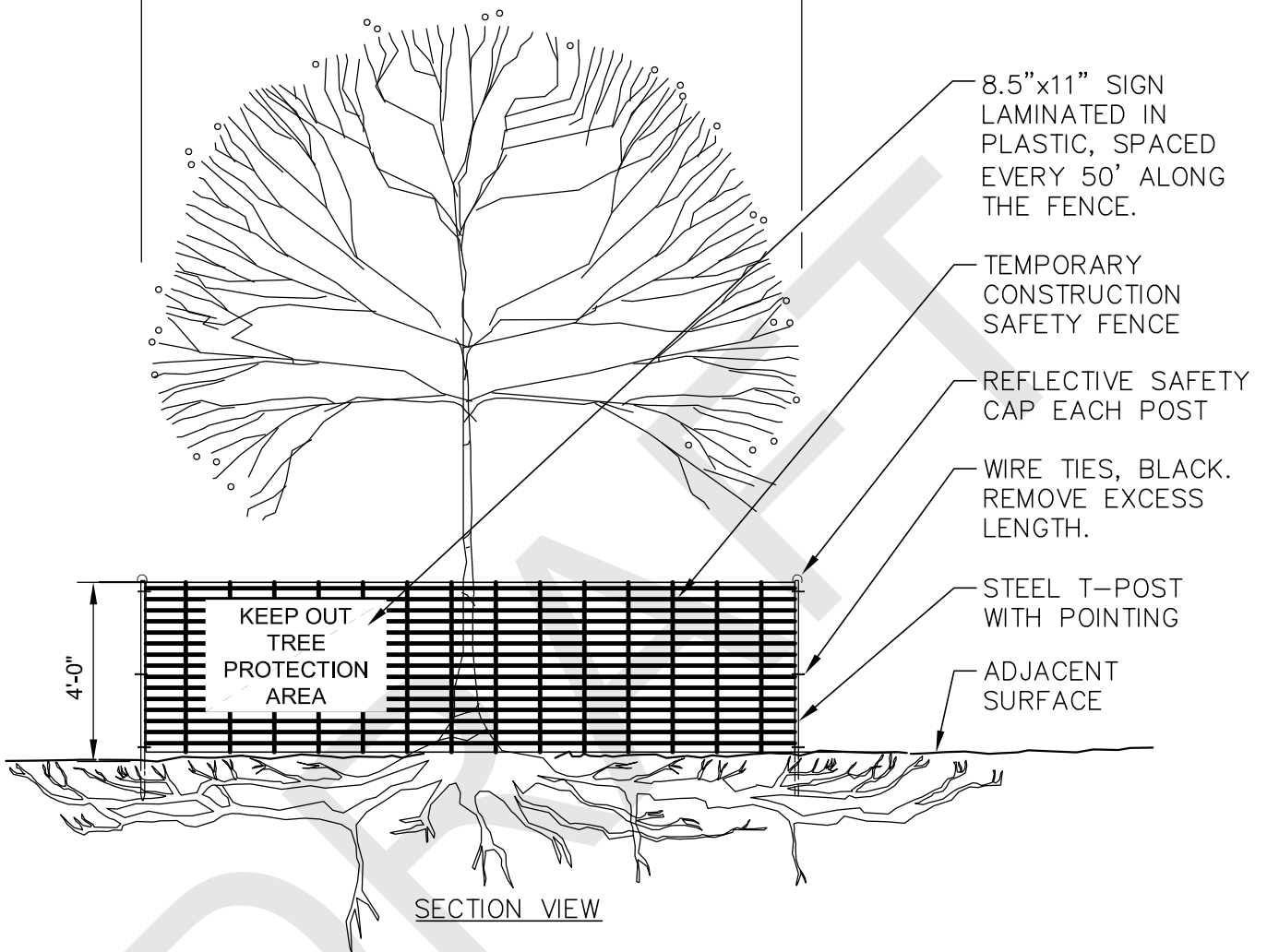

NOTES:

1. SEE MUNICIPALITY OF ANCHORAGE STANDARD SPECIFICATIONS (MASS), SECTION 75.02 FOR ADDITIONAL TREE PROTECTION REQUIREMENTS.
2. NO PRUNING SHALL BE PERFORMED EXCEPT BY ARBORIST.
3. NO EQUIPMENT SHALL OPERATE INSIDE THE PROTECTIVE FENCING INCLUDING DURING FENCE INSTALLATION AND REMOVAL.

MUNICIPALITY



OF ANCHORAGE

SCALE:
NTS

APPROVED:

REVISED:

TREE PROTECTION ZONE FENCE

SECTION #
75.14

DETAIL #
75-10

REVISION:

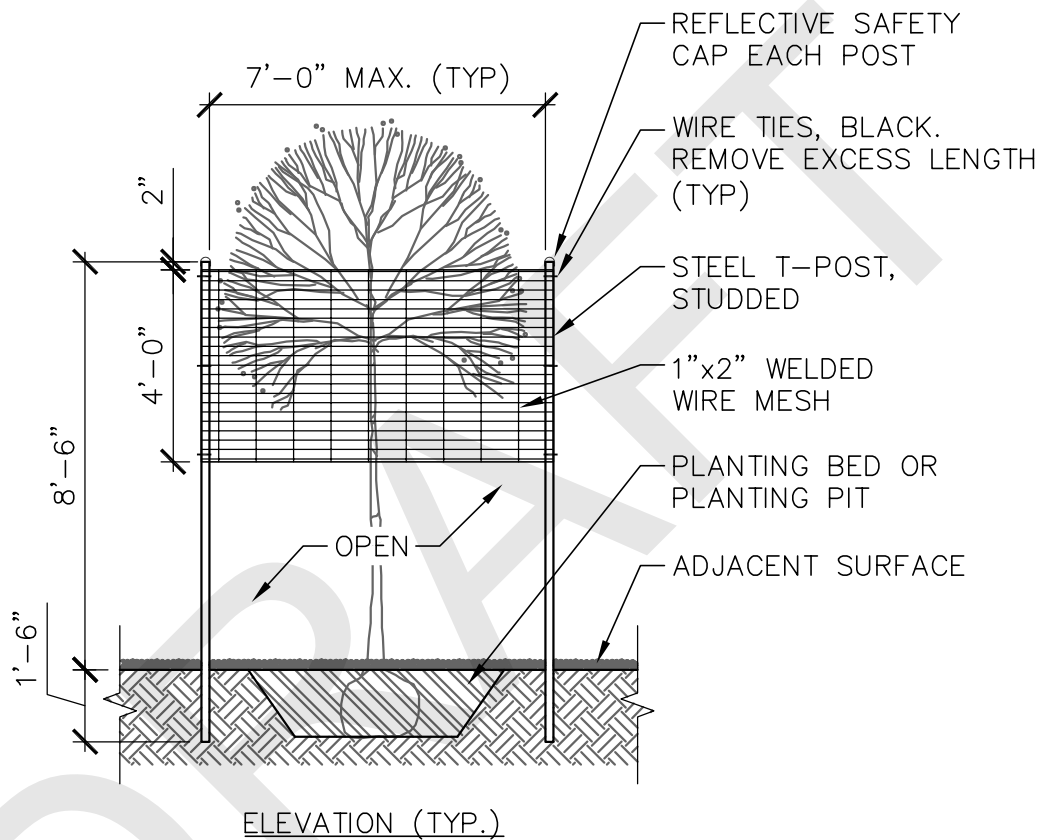

NOTES:

1. MOOSE PROTECTION FENCING REQUIRED AROUND ALL NEW DECIDUOUS TREES.
2. FOR INDIVIDUAL TREES, 3 POSTS (MIN.) REQUIRED PER TREE.
3. FOR TREE GROUPINGS, PLACE T-POSTS SO THAT MESH DOES NOT TOUCH BRANCHES.

MUNICIPALITY



OF ANCHORAGE

SCALE:
NTS

APPROVED:

REVISED:

MOOSE PROTECTION FENCE

SECTION #
75.15

DETAIL #
75-11

REVISION:

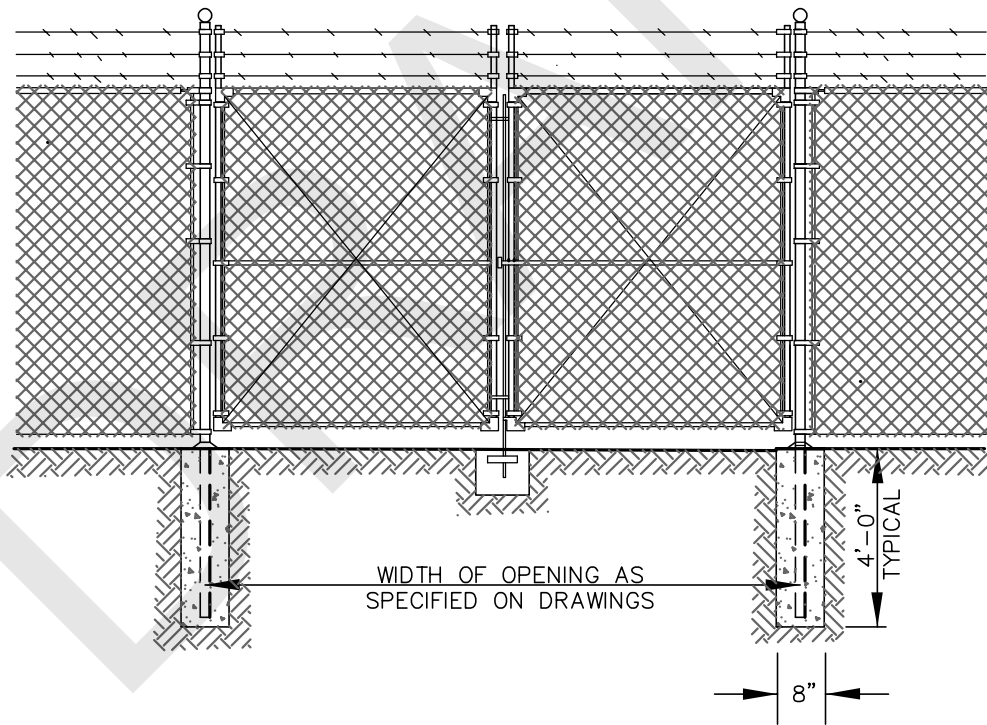
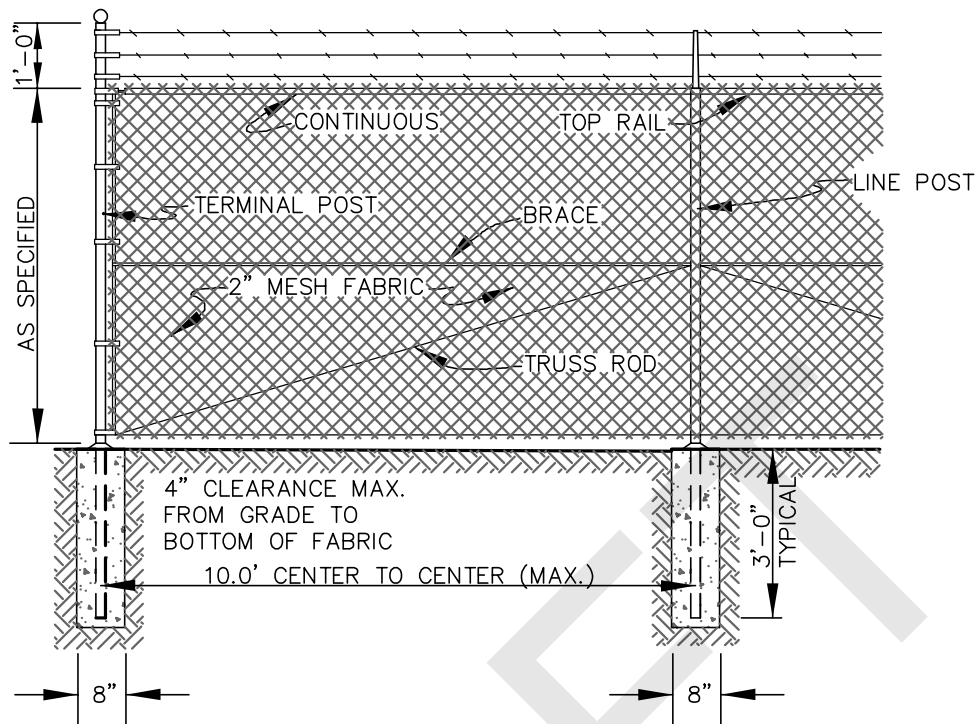

NOTES:

1. GAUGE OF FABRIC AS SPECIFIED ON DRAWINGS.
2. SIZE OF TUBULAR STEEL FOR GATE FRAMES IS SPECIFIED IN SECTION 70.18 – CHAIN LINK FENCES.

MUNICIPALITY



OF ANCHORAGE

SCALE:
NTS

APPROVED:

REVISED:
10/23

FENCE DETAILS

SECTION #
75.17

DETAIL #
75-12

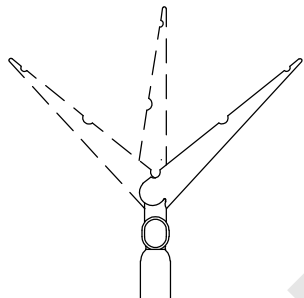
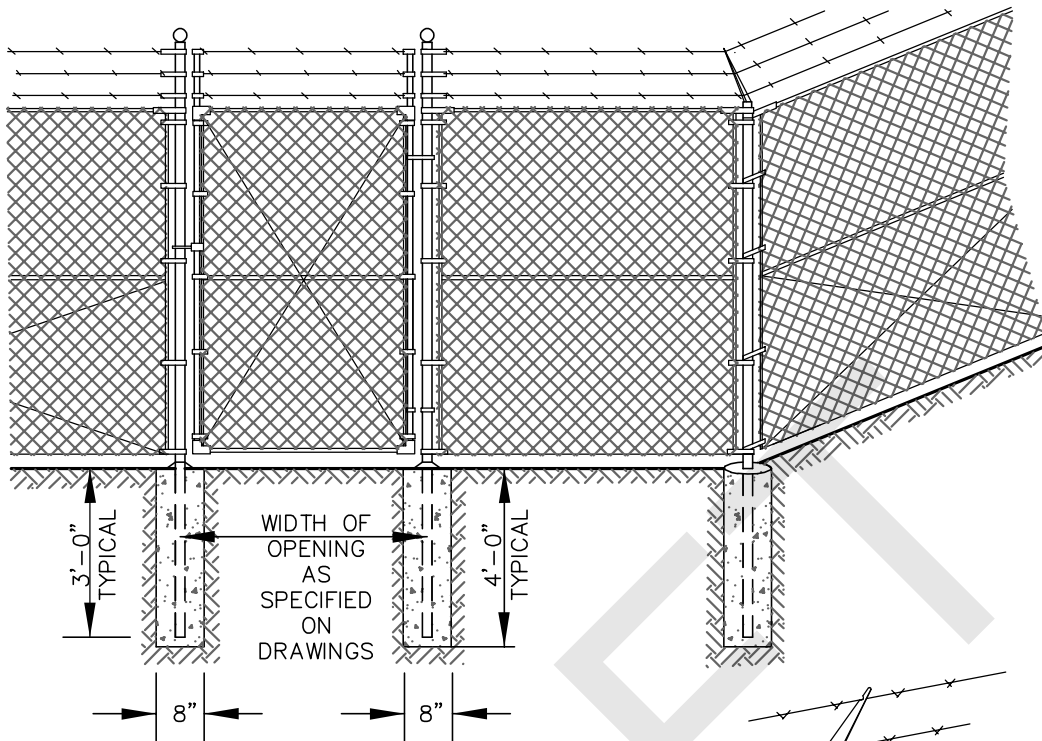

H-H EYETOP
LINETOP FITTING

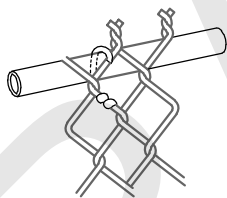

METHOD OF TYING
FABRIC TO TOP RAIL

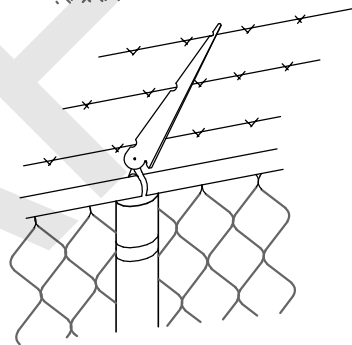

TOP FINISH OF
STEEL GUARD POST

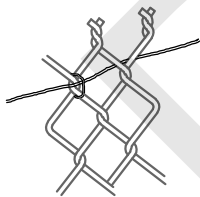

METHOD OF TYING
FABRIC TO COIL
SPRING TENSION WIRE

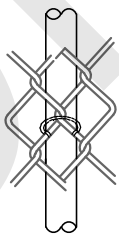

METHOD OF TYING
FABRIC TO TUBULAR
POST

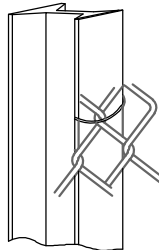

METHOD OF TYING
FABRIC TO H-POST

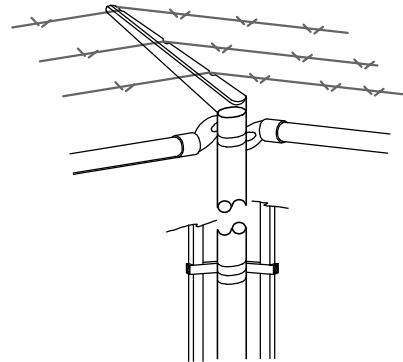

CORNER POST
CONNECTION

NOTE:

1. SIZE OF TUBULAR STEEL FOR GATES IS SPECIFIED IN SECTION 70.18 - CHAIN LINK FENCES.

MUNICIPALITY



OF ANCHORAGE

SCALE:
NTS

APPROVED:

REVISED:
10/23

FENCE DETAILS

SECTION #
75.17

DETAIL #
75-13