

**STANDARD CONSTRUCTION SPECIFICATIONS FOR  
PORTLAND CEMENT CONCRETE  
DIVISION 30  
I N D E X**

SECTION 30.01	GENERAL .....	1
Article 1.1	Scope of Work.....	1
Article 1.2	Applicable Standards .....	1
Article 1.3	Materials .....	2
Article 1.4	Mix .....	6
Article 1.5	Subbase.....	6
Article 1.6	Mix Requirements for Classes of Concrete .....	6
Article 1.7	Ready-Mixed Concrete .....	8
Article 1.8	Sampling and Testing .....	8
Article 1.9	Weather Limitations .....	8
Article 1.10	Protection of Work.....	9
Article 1.11	Clean-up .....	9
SECTION 30.02	PORTLAND CEMENT CONCRETE, CURB AND GUTTER AND VALLEY GUTTER .....	10
Article 2.1	Description .....	10
Article 2.2	Materials .....	10
Article 2.3	Construction .....	11
Article 2.4	Measurement .....	14
Article 2.5	Basis of Payment .....	14
SECTION 30.03	PORTLAND CEMENT CONCRETE SIDEWALKS.....	16
Article 3.1	Description .....	16
Article 3.2	Materials .....	16
Article 3.3	Construction .....	16
Article 3.4	Measurement .....	18
Article 3.5	Basis of Payment .....	18
SECTION 30.04	PORTLAND CEMENT CONCRETE CURB RAMPS.....	19
Article 4.1	General .....	19
Article 4.2	Materials .....	19
Article 4.3	Construction .....	20
Article 4.4	Tolerances .....	21
Article 4.5	Measurement .....	21
Article 4.6	Basis of Payment .....	21
SECTION 30.05	STRUCTURES AND RETAINING WALLS .....	22
Article 5.1	Description .....	22
Article 5.2	Materials .....	22
Article 5.3	Construction .....	22
Article 5.4	Measurement .....	26
Article 5.5	Basis of Payment .....	26

SECTION 30.06	CONCRETE MASONRY RETAINING WALLS .....	27
Article 6.1	Description .....	27
Article 6.2	Materials .....	27
Article 6.3	Construction .....	27
Article 6.4	Measurement .....	28
Article 6.5	Basis of Payment .....	28
SECTION 30.07	PORTLAND CEMENT CONCRETE DRIVEWAY .....	30
Article 7.1	General .....	30
Article 7.2	Materials .....	30
Article 7.3	Construction .....	30
Article 7.4	Measurement .....	30
Article 7.5	Basis of Payment .....	30
SECTION 30.08	PORTLAND CEMENT CONCRETE CLUSTER MAILBOX BASE .....	31
Article 8.1	General .....	31
Article 8.2	Materials and Installation .....	31
Article 8.3	Construction .....	31
Article 8.4	Measurement .....	31
Article 8.5	Basis of Payment .....	31
SECTION 30.09	CONCRETE PARKING BUMPERS .....	32
Article 9.1	Description .....	32
Article 9.2	Material .....	32
Article 9.3	Construction .....	32
Article 9.4	Basis of Payment .....	32
SECTION 30.10	COLORED CONCRETE .....	33
Article 10.1	General .....	33
Article 10.2	Materials .....	33
Article 10.3	Construction .....	33
Article 10.4	Measurement .....	33
Article 10.5	Basis of Payment .....	34
SECTION 30.11	SIDEWALK JOINT SEALANT .....	35
Article 11.1	General .....	35
Article 11.2	Materials .....	35
Article 11.3	Construction .....	35
Article 11.4	Measurement .....	35
Article 11.5	Basis of Payment .....	35
SECTION 30.12	HIGH-PERFORMANCE CONCRETE .....	36
Article 12.1	General .....	36
Article 12.2	Materials .....	36
Article 12.3	Mix Requirements .....	37
Article 12.4	Mock-up Sample .....	39
Article 12.5	Construction .....	39
Article 12.6	Measurement .....	40
Article 12.7	Basis of Payment .....	40

**STANDARD CONSTRUCTION SPECIFICATIONS FOR  
PORTLAND CEMENT CONCRETE  
DIVISION 30**

**SECTION 30.01 GENERAL**

**Article 1.1 Scope of Work**

The Work covered by this Section consists of providing all plant, labor, equipment, supplies, material, transportation, handling, storage and protection for performing all operations in connection with the placement of Portland Cement Concrete in accordance with the Specifications and the Drawings.

**Article 1.2 Applicable Standards**

The latest revision of the following standards of the American Society for Testing and Materials (ASTM) and American Society of State Highway and Transportation Officials (AASHTO) are hereby made a part of these Specifications:

American Concrete Institute "Manual of Concrete Practice"

Concrete Reinforcing Steel Institute "Manual of Standard Practice"

ASTM A184 Specification for Welded Deformed Steel Bar Mats for Concrete Reinforcement

ASTM A615 AASHTO M 31 Specification for Deformed and Plain Carbon and Low Alloy Steel Bars for Concrete Reinforcement

ASTM C31 AASHTO T 23 Method of Making and Curing Concrete Compression and Flexure Test Specimens in the Field

ASTM C33 Specification for Concrete Aggregates

ASTM C330 Specification for Lightweight Aggregates for Structural Concrete

ASTM C39 AASHTO T 22 Test for Compressive Strength of Cylindrical Concrete Specimens

ASTM C40 AASHTO T 21 Test for Organic Impurities in Fine Aggregates for Concrete

ASTM C42 AASHTO T 24 Method of Obtaining and Testing Drilled Cores and Sawed Beams of Concrete

ASTM C90 Hollow Load-Bearing Concrete Masonry

ASTM C94 AASHTO M 157 Specification for Ready-Mix Concrete

ASTM C143 AASHTO T 119 Test for Slump of Hydraulic-Cement Concrete

ASTM C150 AASHTO M 85 Specification for Portland Cement

ASTM C156 AASHTO T 155 Test for Water Retention Efficiency of Liquid Membrane-Forming Compounds and Impermeable Sheet Materials for Curing Concrete.

ASTM C171 AASHTO M 171 Specification for Waterproof Paper for Curing Concrete

ASTM C172	AASHTO T 141	Sampling Fresh Concrete
ASTM C192	AASHTO T 126	Method of Making and Curing Concrete Compression and Flexure Test Specimens in the Laboratory
ASTM C226	AASHTO M 134	Specification for Air-Entraining Additions for Use in the Manufacture of Air-Entraining Portland Cement
ASTM C231	AASHTO T 152	Test for Air Content of Freshly Mixed Concrete by the Pressure Method
ASTM C260	AASHTO M 154	Specification for Air-Entraining Admixture for Concrete
ASTM C270		Mortar for Unit Masonry (Including Tentative Revision)
ASTM C309	AASHTO M 148	Specification for Liquid Membrane-Forming Compounds for Curing Concrete
ASTM C330	AASHTO M 195	Specifications for Lightweight Aggregates for Structural Concrete
ASTM C494	AASHTO M 194	Specifications for Chemical Admixtures for Concrete
ASTM C1240	AASHTO M 307	Specification for Silica Fume Used in Cementitious Mixtures
ASTM D1557	AASHTO T 180	Moisture-Density Relations of Soils Using a 4.54-kg (10-lb) Rammer and a 457-mm (18-in.)
ASTM D1751	AASHTO M 213	Specification for Preformed Expansion Joint Filler for Concrete Paving and Structural Construction (Nonextruding and Resilient Bituminous Types)
	AASHTO M 6	Specification for Fine Aggregate for Portland Cement Concrete
	AASHTO M 32	Specification for Cold Drawn Steel Wire for Concrete Reinforcement Cement
	AASHTO M 80	Specification for Coarse Aggregate for Portland Concrete
ASTM A1064	AASHTO M 336	Specification for Carbon-Steel Wire and Welded Wire Reinforcement, Plain and Deformed, for Concrete

### **Article 1.3 Materials**

#### **A. Reinforcing Steel**

Concrete reinforcing shall be deformed steel bars conforming to the requirements of ASTM A615 (AASHTO M 31). It shall be free from loose scales, excessive rust, and coatings of any character which will reduce the bond between steel and concrete.

If reinforcing bars are to be welded, these Specifications shall be supplemented by requirements assuring satisfactory weldability in conformity with AWS D12.1, "Recommended Practices for Welding Reinforcing Steel, Metal Inserts and Connections in Reinforced Concrete Construction."

#### **B. Welded Steel Wire Fabric**

The welded steel wire fabric shall be cold-drawn steel wires, fabricated into mesh formed by the process of electric welding. The grade of wire shall conform to

AASHTO M 32. Welded Steel Wire Fabric shall conform to ASTM A1064 (AASHTO M 336).

C. Cement

The cement shall be of a recognized standard brand of Portland Cement conforming to the specification requirements listed below and of a type listed below:

<u>Specification</u>	<u>Type Portland Cement</u>
ASTM C150	Type I, III*
AASHTO M 85	Type I, III*

\*Type III cement may be used upon written authorization of the Engineer subject to the following modification:

Minimum design strength shall be achieved in seven (7) days in lieu of the twenty-eight (28) days required for Type I cement.

For architectural concrete only one brand of cement shall be used unless otherwise approved by the Engineer. When no type cement is specified, the requirements of Type I shall govern.

Cement reclaimed from cleaning bags or leaking containers shall not be used.

The Engineer may require an additional one-half sack of Portland concrete over the design specification.

D. Water

Water used for the mixing of concrete shall be clean and free of oil or acid, and shall not contain salt, alkali, or organic matter.

E. Aggregates

Aggregates for Portland Cement Concrete shall be well graded, clean, hard gravel, and coarse sand, non-frost susceptible material, and free of deleterious (organic) matter, and coatings of silt or clay. The gradations shall be determined by standard laboratory sieves with square openings. Material retained on a No. 4 screen shall be classified as coarse aggregate, which shall conform to the requirements of AASHTO M-80 and have the following limits of gradation:

Coarse Aggregate for Portland Cement Concrete

U.S. Standard Sieve Size	AASHTO No. 67 ( $\frac{3}{4}$ " to #4)	AASHTO No. 4 (1 $\frac{1}{2}$ " to $\frac{3}{4}$ ")
	Cumulative % Passing By Weight	Cumulative % Passing By Weight
2"	-----	100
1 $\frac{1}{2}$ "	-----	90–100
1"	100	20–55
$\frac{3}{4}$ "	90–100	0–15
$\frac{1}{2}$ "	-----	-----

3/8"	20-55	0-5
#4	0-10	-----
#8	0-5	-----

All material passing a No. 4 sieve shall be classified as fine aggregate and shall conform to the requirements of AASHTO M 6 and have the following gradation:

Fine Aggregate for Portland Cement Concrete

U.S. Standard Sieve Size	Cumulative % Passing By Weight
3/8"	100
#4	95-100
#8	80-100
#16	50-85
#30	25-60
#50	10-30
#100	2-10

Aggregates shall consist of washed sand gravel; fine and coarse aggregates shall be regarded as separate ingredients. Aggregates for normal weight concrete shall conform to the requirements of ASTM C33 and aggregates for light weight concrete, shall conform to the requirements of ASTM C330.

The maximum size of coarse aggregates shall not exceed one and one-half inches (1 1/2") nor one-fifth (1/5) of the narrowest dimension between the forms nor three-quarters (3/4) of the clear spacing between reinforcing bars nor one-third (1/3) of the depth of slabs. The combined aggregates, coarse and fine, shall be of such composition of sizes that when separated on the No. 4 standard sieve, the weight passing shall not be less than thirty percent (30%) nor greater than fifty percent (50%) of the total weight.

The volume removed by sedimentation shall not exceed three percent (3%). Proportioning of the coarse and fine aggregate shall be obtained by weight. The weighing equipment shall be accurate within one percent (1%) of the net weight of the batch and shall permit adjustment for variations in the water content of the aggregate. Batching for fractional sacks of cement will not be permitted unless the cement is weighed for each batch. The water added shall be measured by an approved calibrated device capable of metering within one percent (1%) of the total amount of water to be used for each batch.

F. Air-Entrainment

Air-entrainment agents shall be used in all concrete. Entrainment shall be achieved by the addition of an approved air-entraining mixture to the concrete mix. Air-entrainment shall conform to ASTM C231 (AASHTO T 152). Refer to Article 1.6 - Mix Requirements for Classes of Concrete for air-entrainment percentages for each class of concrete.

G. Curing Materials

Curing materials shall be one the following types as approved by the Engineer:

1. Kraft paper conforming to the requirements of ASTM C171 (AASHTO M 171).
2. Mats of commercial quality and of a type used for curing concrete.

3. Burlap of commercial quality weighing not less than fourteen (14) ounces per square yard.
4. Membrane curing compound conforming to the requirements of ASTM C309 (AASHTO M 148).

#### H. Expansion Joints

Premolded joint filler for use in expansion joints shall conform to the requirements of ASTM D1751 (AASHTO M 213).

### **Article 1.4 Mix**

Portland Cement Concrete may be mixed at a central mixing plant or in transit mixers. All mixing equipment and operations shall conform to the requirements of ASTM C94 (AASHTO M 157). All concrete shall be delivered to the work site thoroughly mixed to a uniform color and show uniform distribution of aggregates and cement throughout the mixture.

Concrete shall be delivered to the Project site, discharged from the truck completely and in the forms ready for vibration within one and one-half (1-1/2) hours after introduction of the cement to the aggregates. At the discretion of the Engineer, the above period may be extended one (1) minute for every degree of temperature at which the concrete is delivered below seventy degrees (70°) Fahrenheit to a maximum total time of two (2) hours.

In hot weather, or under conditions contributing to quick setting of the concrete, a discharge time less than one and one-half (1-1/2) hours may be required by the Engineer. Any concrete remaining undischarged at the end of the respective time period shall be rejected.

The use of non-agitating equipment for transporting concrete will not be permitted. The mixing drums of transit-mix trucks shall be thoroughly washed after discharging each load to prevent the accumulation of adherent layers of concrete. The discharge of particles of hardened concrete with any batch will be sufficient grounds for the rejection of the entire batch. On curb, gutter and sidewalk work, transit mix trucks shall be operated parallel to the forms while discharging.

The addition of water to the mix at the job site will be permitted with the approval of the Engineer. Any additional water that is added shall be documented and recorded on the delivery ticket by a representative of the supplier.

### **Article 1.5 Subbase**

Prior to placement of forms, the Engineer shall inspect the subbase to insure that it is smooth, compacted and free of soft or yielding spots and that compaction at optimum moisture is at least ninety-five percent (95%) of maximum density (AASHTO T 180 D). Backfilling within the forms will be permitted if the subbase is brought to the above specification and care is taken to maintain the forms to line, shape elevation.

### **Article 1.6 Mix Requirements for Classes of Concrete**

The minimum mix requirement for classes of concrete shall be as set forth below, unless otherwise specified in the Contract Documents. For conversion purposes, the



estimating factor for one (1) sack of concrete shall be ninety-four (94) pounds. One (1) gallon of water shall be eight and three tenths (8.3) pounds.

	CLASS OF CONCRETE							
	C-6	B-3	B-6	A-3	A-6	AA-3	AA-6	
Minimum Cement Content in Sacks/Cu. Yd.	4.5	5.0	5.0	5.5	5.5	6.0	6.0	
Maximum Water Content Ratio in Gal./Sack	6.5	6.5	6.5	6.5	6.5	5.0	5.5	
Slump Ranges in Inches	1-5	2-4	1-3.5	2-4	1-3.5	2-4	1-2	
Entrained Air Range in Percentage	3-6	4-7	3-6	4-7	3-6	5-8	3-6	
Coarse Aggregate (AASHTO Gradation)	No.4 and No. 67	No. 67	No. 4* and No. 67	No. 67	No. 4* and No. 67	No. 67	No. 4* and No. 67	

Fine Aggregate Shall Conform to AASHTO M-6 Gradation

Minimum Design Strength (fc), psi	2000	2500	2500	3000	3000	4000	3500
-----------------------------------	------	------	------	------	------	------	------

Minimum design compressive strength specification shall be achieved in twenty-eight (28) days.

\*The coarse aggregate for Class B-6, A-6, and AA-6 concrete shall be furnished in two (2) separate sizes.

Alternate mix designs will be considered upon submitting to the Engineer the following information:

1. MOA mix design designation for which the substitution is intended.
2. Design strength.
3. Air content.
4. Slump.
5. Aggregate gradation and maximum size.
6. Maximum water/cement ratio.
7. Minimum cement content.
8. List of admixtures, strength overdesign, and other special features.
9. Fine aggregate weight/percent moisture of fine aggregate.
10. Intermediate aggregate weight/percent moisture of intermediate aggregate.
11. Coarse aggregate weight/percent moisture of coarse aggregate.
12. Weight of cement.
13. Weight of water.
14. Unit weight.

Water shall not be used to increase slump beyond four inches (4"). If additional slump is desired, a plasticizing agent may be used subject to the Engineer's written approval.

### **Article 1.7 Ready-Mixed Concrete**

Ready-mixed concrete shall conform to the requirements of ASTM C94 (AASHTO M 157). For each batch of concrete, it is the responsibility of the Contractor to furnish to the Engineer, before unloading at the site, a delivery ticket from the manufacturer on which is printed, stamped or written, information concerning said concrete as follows:

1. Name of ready-mix batch plant.
2. Serial number of ticket.
3. Date and truck number.
4. Name of Contractor.
5. Specific designation of Project (name and location).
6. Specific class of concrete in conformance with that employed in Specifications.
7. Amount of concrete (cubic yards).
8. Time loaded or first mixing of cement and aggregate.
9. Type of cement.
10. Admixtures and amount of same.
11. Slump requested by the Contractor and recorded in inches.
12. Percentage of entrained air requested by the Contractor.
13. Fine aggregate weight/percent moisture of fine aggregate.
14. Intermediate aggregate weight/percent moisture of intermediate aggregate.
15. Coarse aggregate weight/percent moisture of coarse aggregate.
16. Weight of cement.
17. Weight of water.
18. Unit weight.

### **Article 1.8 Sampling and Testing**

The Engineer shall take concrete samples for concrete cylinders in accordance with AASHTO T 141. Samples shall not be taken at the beginning or end of discharge. Making and curing the specimens shall be done in accordance with AASHTO T 23. Testing and sampling shall be done by the Engineer.

Slump tests shall be taken in accordance with AASHTO T 119 or ASTM C143. Slump tests shall be taken by the Engineer.

Should the analysis of any test cylinder not meet the requirements of these Specifications, all concrete placed from the batch represented by the cylinder shall be removed and replaced at the Contractor's expense.

### **Article 1.9 Weather Limitations**

Placement of Portland Cement Concrete is subject to the following requirements:

1. Salt, chemicals, or other material shall not be mixed with the concrete to prevent freezing.

2. Placement of concrete shall be prohibited whenever there is standing water on the grade or in the forms, the subgrade is yielding due to saturation, or rain is threatening.
3. Approved admixture shall be used in accordance with the manufacturer's recommendations.

Ensure the concrete temperature is between fifty degrees (50°) Fahrenheit and ninety degrees (90°) Fahrenheit when placed. If ambient air temperature falls below forty degrees (40°) Fahrenheit at any time during the cure period defined in Article 1.10 Protection of Work, concrete shall be protected by the placement of insulating blankets over the surface area and/or application of heat as necessary to maintain a surface temperature greater than fifty degrees (50°) Fahrenheit.

Placement of concrete shall be prohibited at an ambient air temperature above ninety degrees (90°) Fahrenheit and below forty degrees (40°) Fahrenheit or where the foundation material is frozen, except in special situations where authorized by the Engineer in writing. Exemption from the temperature clause of these Specifications shall be considered only under the following conditions:

A written proposal shall be submitted by the Contractor to the Engineer outlining a procedure for maintaining the placed concrete temperature of at least fifty degrees (50°) Fahrenheit for seventy-two (72) hours where Type III cement has been used and one hundred and twenty (120) hours where Type I cement has been used. When the temperature is reduced, the drop in temperature must be gradual and not exceed thirty degrees (30°) Fahrenheit in the first twenty-four (24) hours.

#### **Article 1.10 Protection of Work**

The Contractor shall protect all newly placed concrete from damage of any kind to prevent disfigurement during the curing period. Do not apply loads to the concrete until curing operations are completed and until the Engineer determines the concrete has attained sufficient strength to safely carry the applied loads without damage. Damaged concrete shall be repaired or replaced to the Engineer's satisfaction at no additional cost.

Type I/II/III Portland Cement Concrete shall be placed, finished, cured at a minimum temperature of fifty degrees (50°) Fahrenheit. The concrete shall be protected until lab testing of field-cured specimens has attained at least 80 percent of the Specified Compressive Strength prior to material being distributed against, or vibrated (compaction) adjacent to the structure, as directed by the Engineer. In the event where concrete samples are misplaced or stolen in the field or lab testing is unavailable, a minimum of seven (7) days protection period shall be provided.

#### **Article 1.11 Clean-up**

When all concrete Work has been completed and cured, the Contractor shall remove the forms, stakes, blocking, and concrete spoil from the site. The area adjoining the concrete that was excavated to permit the construction and placement of forms shall be filled with select material, and the slopes and parking areas, if any, shall be filled, shaped and smoothed to the level as shown on the Drawings or Standard Details.

## **SECTION 30.02 PORTLAND CEMENT CONCRETE, CURB AND GUTTER AND VALLEY GUTTER**

### **Article 2.1 Description**

The Work covered under this Section consists of the construction of Portland Cement Concrete curb and gutter, valley gutters, and curb noses. The construction for curb and gutter at narrowing tapers shall be a High-Performance Portland Cement Concrete.

### **Article 2.2 Materials**

Portland Cement Concrete, joint filler, reinforcing steel, and curing materials shall conform to Section 30.01, Article 1.3 - Materials. Concrete mix for the curb and gutter, valley gutters, and curb noses shall conform to the requirements for Class AA-3 unless otherwise specified.

High-Performance Portland Cement Concrete, joint filler, reinforcing steel, and curing materials shall conform to Section 30.12, Article 12.2 – Materials with the exception the color of the concrete shall be a standard grey. Concrete mix for the curb and gutter at narrowing tapers shall conform to Section 30.12, Article 12.3 – Mix Requirements.

#### **A. Reinforcing Steel and Steel Dowels**

Refer to Section 30.01, Article 1.3, SubArticle A. - Reinforcing Steel and SubArticle B. - Welded Steel Wire Fabric.

#### **B. Preformed Expansion and Dummy Joint Filler**

Refer to Section 30.01, Article 1.3, SubArticle H. - Expansion Joints.

#### **C. Curing Compounds**

Refer to Section 30.01, Article 1.3, SubArticle G. – Curing Materials.

#### **D. Forms**

Forms may be of wood or metal or any other material at the option of the Contractor, provided that the forms as set will result in a curb, or curb and gutter of the specified thickness, cross section, grade and alignment shown on the Drawings.

Forms may be removed the same day following pour if the concrete is sufficiently set that removal can be accomplished without danger of chipping or spalling. Form materials shall be free from warp, with smooth and straight upper edges, and if used for the face of a curb, shall be surfaced on the side against which the concrete is to be placed. Wooden forms for straight work shall have a net thickness of at least one and one-half inches (1.5"). Metal forms for such a work shall be of a gage that will provide equivalent rigidity and strength. Curb face forms used on monolithic curb and gutter construction shall be a single plank width when the curb face is ten inches (10") or less, except for those used in curb returns. All forms used in curb returns shall not be less than three-quarters inches (3/4") in thickness, cut in the length and radius as shown on the Drawings, and held rigidly in place to line and grade by the use of metal stakes and clamps. The curb face form shall be cut to conform exactly with the curb face batter as well as

being cut to the required length and radius. Forms shall be of sufficient rigidity and strength, and shall be supported to adequately resist springing or deflection from placing and tamping of concrete.

Form material shall be clean and free from defect at the time of use.

All forms including back planks of curb shall be set with upper edges flush with specified alignment and grade of the finished surface of the improvements to be constructed, and all forms shall be not less than a depth equivalent to full specified thickness of the concrete to be placed.

Forms shall be held securely in place by means of metal stakes to insure no irregularities in the forms. Placement of the metal stakes shall not exceed three feet (3'). Clamps, spreaders, and braces shall be used to the extent as may be necessary to insure proper form rigidity. Forms for walk and similar work shall be firmly secured by means of stakes driven at intervals not to exceed four feet (4'). Form stakes shall be of sufficient size and be driven so as to adequately resist lateral displacement.

Commercial form clamps for curb and gutter may be used provided they fulfill the requirements specified herein.

Pump trucks may be used upon approval of the Engineer. Prior to approval, the Contractor must demonstrate to the satisfaction of the engineer that the pumping equipment will not segregate, or in any other way degrade, the concrete. Additional test samples for such alternate placement methods may be taken from the discharge side of the machine for compressive strength determination assurance tests.

## **Article 2.3 Construction**

### **A. Erecting Forms**

All forms shall be set to the lines, grade, and dimensions shown on the Drawings. The forms shall be thoroughly braced and secured to resist deformation or displacement under load, and shall be installed to permit easy removal without hammering or prying against the fresh concrete. The top of the forms shall not deviate more than one-eighth inch (1/8") in ten feet (10'), and the alignment of forms shall be within one-fourth inch (1/4") in ten feet (10').

Before placement of concrete, steel forms shall be lightly oiled with a good grade of form oil. Excess oil shall be removed by wiping with clean rags, dampened in diesel or fuel oil. Wooden forms may be oiled in the same manner as metal forms, or they may be watered immediately in advance of the placement of concrete. Watering of the form shall be done with clean water of the same quality as that specified for mixing water, and only when the atmospheric temperature is not less than forty degrees (40°) Fahrenheit. Concrete shall not be placed until all forms have been inspected and approved by the Engineer. Wherever form work is exposed to pedestrian traffic, bridges (not attached to the forms) shall be provided at all regular pedestrian crossings where it is required to maintain safety standards. Barricades and other safety features shall be installed as necessary.

### **B. Placing Concrete**

Prior to the delivery of the first load of concrete for curbs, the Contractor shall furnish rigid straightedges, ten feet (10') or sixteen feet (16') in length, to the Engineer for checking surface uniformity. String shall not be used as a straightedge. Surface irregularities, as measured along the top face of curb and the curb pan, shall not exceed three-sixteenth inch (3/16") within ten feet (10'), or five-sixteenth inch (5/16") within sixteen feet (16'). Non-conforming surfaces shall be subject to rejection by the Engineer. All surfaces rejected by the Engineer shall be corrected by the Contractor at the Contractor's expense.

The subgrade shall be properly compacted and brought to specified grade in accordance with the Drawings before placing concrete. The subgrade shall be thoroughly dampened immediately prior to the placement of the concrete. Forms shall not be splashed with concrete in advance of placing.

Concrete shall be discharged from transport vehicle to the point of final placement in a continuous manner as rapidly as practicable. The rate of placement shall not exceed the rate at which the various placing and finishing operations can be performed in accordance with these Specifications. Concrete shall not be allowed to free fall more than three feet (3').

If concrete is to be placed by the extruded method, the Contractor shall demonstrate to the satisfaction of the Engineer that the machine is capable of placing a dense, uniformly compacted concrete to exact section, line and grade. Extruded curb which does not meet all requirements of the Contract Documents, shall be replaced at the Contractor's expense.

#### C. Stripping Forms and Finishing

The face form of the curb shall be stripped at such time in the early curing as will enable inspection and correction of all irregularities that appear thereon.

Forms shall not be removed until the concrete has set sufficiently to retain its true shape. The face of the curb shall be troweled with a tool cut to the exact section of the curb and at the same time maintain the shape, grade, and alignment of the curb. Both front and back edges shall be troweled to a radius of one-half inch (1/2"). Final finish shall be obtained by brooming the surface, including the troweled edge to a gritty finish after all free moisture has disappeared from the surface. Sprinkling of cement or sand for blotting will not be permitted.

It is the intent of this Specification to insure the highest quality of workmanship in the construction and finishing of P.C.C. curb and gutter.

Unsightly or poorly finished surfaces will be considered grounds for rejection of the Work. The top and/or face and gutter of the finished concrete surfaces shall be true and straight, of uniform width and free of cracks, humps, sags, or other irregularities. The finished concrete surface shall not vary more than two-hundredths of a foot (0.02') from a ten foot (10') straight edge, except at grade changes or curves. No freestanding water is permitted on slopes at or greater than one percent (1%). No freestanding water deeper than one-sixteenth inch (1/16") is permitted on slopes of less than one percent (1%). The Contractor shall flow test all new concrete curb and gutter. Curb and gutter failing to meet this requirement will be rejected.

All defective areas shall be removed and replaced at the Contractor's expense, unless permission to patch is granted by the Engineer. Such permission shall not be construed as an acceptance of the Work or as a waiver of the Engineer's right to require the complete removal of the Work, if in his opinion the patch does not satisfactorily restore the quality or appearance of the surface.

Should patching be permitted, the area shall be chipped clean to a depth of one inch (1") perpendicular to the surface and saturated with clean water prior to being patched. The patch shall be made with a mortar extracted from fresh concrete by passing it through a three-eighths inch (3/8") screen. The mortar shall be thoroughly compacted and screeded off slightly higher than the surrounding surface to allow for contracting or setting after the maximum shrinkage has taken place. After one (1) to two (2) hours, the patch shall be troweled to the same finish as the surrounding area and shall be cured as specified herein. The use of special patching material will be permitted if approved by the Engineer.

#### D. Curing

Curing compounds shall be applied to all exposed surfaces immediately after finishing. Transparent of sufficient strength to render the film distinctly visible on the concrete for a minimum period of four (4) hours after application.

If, at any time during the curing period any of the forms are removed, a coat of curing compound shall be applied immediately to the exposed surface. The curing compound shall be applied in sufficient quantity to obscure the natural color of the concrete. Additional coats shall be applied if the Engineer determines that the coverage is not adequate. The concrete shall be cured for the minimum period of time set forth in Section 30.01, Article 1.10.

When forms are removed before the expiration of the curing period, the edges of the concrete shall be protected with moist earth, or sprayed with curing compound.

Other standard methods of curing the curb and gutter may be used upon approval of the Engineer. Concrete shall not be placed unless curing compounds and necessary equipment for applying such is on the Project site.

#### E. Expansion and Contraction Joints

##### 1. Expansion Joints

Expansion joints shall be placed along all structures, as shown in the Drawings and/or Standard Details, and around all features that project into, through, or against the concrete. An expansion joint shall be constructed at the intersection of sidewalks; between sidewalk crossings and sidewalks; between curbs and sidewalks (except parallel curb); where existing and proposed curbs and sidewalks meet; and at the beginning and end of curb returns. Additionally expansion joints shall be constructed every fifty feet (50'). Expansion joint material shall conform to the requirements of ASTM D1751 (AASHTO M 213). Expansion joints shall not exceed one half inch plus or minus one-eighth inch ( $1/2" \pm 1/8"$ ) in width. Expansion joint material shall extend the full width of the structure and shall be cut to such dimensions that the base of the expansion joint shall extend to the subgrade

and the top shall be depressed not less than one-quarter inch (1/4") nor more than one-half inch (1/2") below the finished surface of the concrete. The material shall be of one (1) piece in the vertical dimension and shall be securely fastened in a vertical position to the existing concrete face against which fresh concrete is to be placed. After the concrete has set, the expansion joints shall be filled flush to the finish concrete surface with an approved polyurethane or hot applied asphalt-based sealant applied according to the manufacturer's recommendation.

Before sealing, the joint shall be cleaned of all dirt, gravel, concrete mortar, and other extraneous material. Sealing shall be done in a neat workmanlike manner.

## 2. Contraction Joints

Transverse contraction joints, cut to a depth of one inch (1") prior to the final set of the concrete, shall be tooled in the sidewalks at intervals of five feet (5'), and at ten feet (10') intervals in the curb and gutter. Where the sidewalk adjoins the curb (parallel to it), contraction joints in the sidewalk and curb shall be made to match where practicable.

### **Article 2.4 Measurement**

Curb or integral curb and gutter shall be measured per linear foot along the face of the curb. Mountable (rolled) curb and gutter shall be measured per linear foot along the gutter line. Portland Cement Concrete (P.C.C.) Valley Gutter shall be measured as shown on the Standard Detail.

Curb containing steel curb facing shall be measured per linear foot along the face of the curb and the designation "Steel Curb Facing" shall be included in the "Type" description of the pay item. Steel curb facing is incidental to the "P.C.C. Curb and Gutter (Steel Curb Facing)" bid item.

High-Performance Portland Cement Concrete (P.C.C.) curb or integral curb and gutter shall be measured per linear foot along the face of the curb.

Medians with curb noses shall be measured as follows: P.C.C. curb and gutter per linear foot, curb noses as units complete in place. Striping on curb noses will be paid under Division 70 and no payment shall be made in this section.

### **Article 2.5 Basis of Payment**

Payment for this Work shall be in accordance with Division 10, Section 10.07 - Measurement and Payment and shall include full payment for all Work described in this Section.

Payment shall be made under the following units unless otherwise specified:

ITEM	UNIT
P.C.C. Curb and Gutter (Type)	Linear Foot
P.C.C. Curb and Gutter (Type) (High-Performance)	Linear Foot
P.C.C. Valley Gutter	Linear Foot
Curb Nose	Each



Extra payment will not be made for depressed curb or special sections.

## **SECTION 30.03 PORTLAND CEMENT CONCRETE SIDEWALKS**

### **Article 3.1 Description**

The Work covered under this Section consists of all Work necessary for the provision of Portland Cement Concrete sidewalks.

### **Article 3.2 Materials**

The Portland Cement Concrete, joint filler, reinforcing steel, and curing materials shall conform to Section 30.01, Article 1.3 - Materials. Concrete mix for sidewalks shall conform to the requirements for Class AA-3 unless otherwise specified.

### **Article 3.3 Construction**

#### **A. Excavation and Embankment**

Excavation and embankment for sidewalks shall be as described in Division 20 - Earthwork. Where directed by the Engineer, unsuitable material in the subgrade shall be removed to a specific depth and then backfilled with classified fill. Payment will not be allowed for excavation below grade or for backfill materials required when such excavation is caused by negligence of the Contractor.

Embankment shall be compacted to ninety-five percent (95%) maximum density in accordance with Division 20, Section 20.01, Article 1.5 - Compaction Standards. In areas that are inaccessible to normal compaction equipment, approved tampers shall be used.

Before the forms are set, the subgrade shall be graded to within one inch (1") of established grade and the area between the sidewalk and the adjacent private property line shall be shaped to line, grade, and section shown on the Drawings.

#### **B. Forms and Fine Grading**

Forms shall conform to requirements outlined in Section 30.02 - Portland Cement Concrete, Curb and Gutter, and Valley Gutter. Wood forms against unexposed concrete surfaces shall be No. 2 Common Lumber or better. Those against surfaces to be exposed shall be dressed and matched boards of uniform thickness, and widths not exceeding ten inches (10"). Rigid, nonporous and waterproof sheet material may be used provided the end result will be a smooth unmarked concrete surface without waves, fins or other noticeable markings.

Plywood conforming to the requirements for form work, as set forth by the American Plywood Association, may be used against both exposed and unexposed concrete surfaces. This plywood shall be not less than five (5) ply and at least nine-sixteenths inch (9/16") thick. Low areas in the subgrade shall be backfilled with classified fill or with suitable native material as directed by the Engineer. The backfill shall then be compacted to ninety-five percent (95%) maximum density and any dry areas in the subgrade shall be thoroughly dampened prior to the time the concrete is placed. No payment will be made for water, and the work of placing and cost thereof shall be considered as incidental to the construction of the concrete sidewalk.

### C. Welded Steel Wire Fabric

The welded steel wire fabric shall be positioned as indicated on the Drawings or as hereinafter specified. Concrete sidewalks adjoining driveways shall be reinforced with welded steel wire fabric. D. Placing and Finishing Portland Cement Concrete Sidewalk

The concrete shall be spread uniformly between the forms and thoroughly compacted with a steel shod strikeboard. After the concrete has been thoroughly compacted and leveled, it shall be floated with wood floats and finished at the proper time with a steel float. Joints shall be edged with a one-quarter inch (1/4") radius edger and the sidewalk edges shall be tooled with a one-half inch (1/2") radius edger. After final troweling, sidewalk on grades of less than six percent (6%) shall be given a fine hair broom finish applied transversely to the centerline. On grades exceeding six percent (6%), sidewalk shall be finished by hand with a wood float. Sidewalk shall be re-marked as necessary after final finish to assure neat uniform edges, joints, and score lines. Unsightly, poorly finished, and sidewalk failing to meet the requirements of the Drawings, Specifications, and this Section will be rejected.

The sidewalk shall be divided into panels by scoring one inch (1") deep every five feet (5'). Refer to Section 30.02, Article 2.3, SubArticle E - Expansion and Contraction Joints for requirements for contraction and expansion joints. The expansion joints shall be placed at all structures such as catch basins and manholes, at driveways, and at all points of tangency and points of curvature.

Additional requirements for placing and finishing concrete in cold weather shall be as outlined in Section 30.01, Article 1.9 - Weather Limitations.

For all other exposed aggregate concrete sidewalks, Contractor shall float and trowel all surfaces to receive the exposed aggregate finish. Seeding the surface with aggregate shall not be allowed. After the concrete has taken its initial set, the surface aggregate shall be exposed using a water fog spray and brooms to remove the surface matrix. The coarse surface aggregate shall be exposed very lightly, approximately one-sixteenth inch (1/16"). After the concrete has taken its final set, a weak acid wash shall be applied to clean and wash the exposed aggregate surfaces. The weak acid wash shall be thoroughly neutralized and flushed from the finished surface. Under no circumstances shall Contractor allow the acid wash to enter the storm drain lines.

Contractor shall protect adjacent construction, plantings, finishings, structures, and the public from damage and harm due to the acid wash. The finished appearance of the exposed aggregate concrete sidewalk shall produce an appearance and texture that matches the adjacent exposed aggregate sidewalk. Any significant difference in texture or appearance between two adjacent concrete panels, as determined by the Engineer, shall result in removal and replacement of concrete panels by Contractor at no additional cost.

Contractor shall provide a two foot by two foot (2' x 2') exposed aggregate concrete test panel or provide three (3) projects within the Municipality of Anchorage of exposed aggregate that have been poured prior to constructing the

exposed aggregate concrete sidewalk. Location of the test panel will be on-site as approved by the Engineer. Notification of providing this test panel shall be made to the Engineer no less than 24 hours prior to making the test panels to allow the Engineer and materials analysis personnel to be present. The Engineer may require the Contractor to provide additional panel(s) if the test panel does not produce an appearance that matches the adjacent exposed aggregate sidewalk.

Providing the test panel and any other required test panel shall be considered incidental to the bid item "P.C.C. Sidewalk 4" Thick (Exposed Aggregate)" and no separate payment shall be made.

#### E. Curing and Protection

The materials and procedures outlined in Section 30.02, Article 2.3 - Construction, shall prevail. The curing agent shall be applied immediately after finishing and be maintained for a period of seven (7) days. The curing agent(s) and/or concrete mixtures shall in no way deter or prevent final finishing of concrete. The use of surface retarders may be permitted if application methods are accepted by the Engineer, in writing, no less than twenty-four (24) hours prior to concrete placement.

The Contractor shall have readily available sufficient protective covering, such as waterproof paper or plastic membrane, to cover the pour of an entire day in event of rain or other unsuitable weather.

The sidewalk shall be protected against damage or defacement of any kind until it has been accepted by the Owner. Sidewalk which is not acceptable to the Engineer because of damage or defacement shall be removed and replaced at the expense of the Contractor.

Additional requirements for curing in cold weather shall be as outlined in Section 30.01, Article 1.9 - Weather Limitations.

### **Article 3.4 Measurement**

Sidewalk: Sidewalks shall be measured per square yard, complete in place, for both four (4") and six inch (6") thicknesses.

Sidewalk Retaining Walls: Sidewalks of specified thickness constructed in conjunction with sidewalk retaining walls shall be measured under the provisions of Section 30.05 – Structures and Retaining Walls.

### **Article 3.5 Basis of Payment**

Payment for this item shall be in accordance with Division 10, Section 10.07 - Measurement and Payment and shall include full payment for all Work described in this Section.

Payment shall be made under the following units:

ITEM	UNIT
P.C.C. Sidewalk (Thick) (Type Finish)	Square Yard

## **SECTION 30.04 PORTLAND CEMENT CONCRETE CURB RAMPS**

### **Article 4.1 General**

The Work under this Section consists of performing all operations pertaining to furnishing and constructing Portland Cement Concrete curb ramps with a detectable warning surfacing in conformance with the Drawings. The ramps shall comply with the Americans with Disabilities Act Title II as identified in 28 CFR Part 35 – Nondiscrimination on the Basis of Disability in State and Local Government Services.

### **Article 4.2 Materials**

#### **A. General**

Portland Cement Concrete, joint filler, reinforcing steel, and curing materials shall conform to Section 30.01, Article 1.3 – Materials. Concrete mix for curb ramps shall conform to the requirements for Class AA-3 unless otherwise specified.

The Contractor shall not apply a troweled pattern to the curb ramps. Contractor shall provide a coarse broom finish for the ramps perpendicular to direction of pedestrian traffic.

#### **B. Detectable Warning Panel**

Each detectable warning panel shall have a truncated domed surface twenty-four inches (24") in depth for the width of the ramp. The truncated domes shall have a height of two-tenths inch (0.2"), a diameter of nine-tenths inch (0.9"), a center-to-center spacing of one and six-tenth inches (1.6") minimum and two and four-tenth inches (2.4") maximum, and a base-to-base spacing of sixty-five one-hundredth inch (0.65"), measured between the most adjacent domes.

Contractor shall provide panels Federal Yellow in color. The specified color shall be homogeneous throughout the panel.

Contractor shall provide a cast iron detectable warning plates, or panels (s), manufactured by:

Advantage Tactile Systems  
OR  
241 Main Street, Suite 100  
Buffalo, NY 14203  
Phone: 1-800-679-4022

EJ Group, Inc.  
301 Spring Street  
East Jordon, MI 49727  
Phone: 1-800-626-4653

OR Tuf Tile  
905 Telser Road  
Lake Zurich, IL 60047  
Phone: 1-888-960-8897

or an approved equal.

### **Article 4.3 Construction**

The Contractor shall construct each curb ramp and install the detectable warning panel(s) in conformance with the Contract Documents and the manufacturer's recommendations.

No later than five (5) days prior to construction of the curb ramps, Contractor shall submit to the Engineer for review and approval, a layout drawing for each curb ramp to resolve issues related to pattern repeat, tile cuts, reinforcements, expansion joints, control joints, ramp curves, ramp end returns and surface interfaces, and truncated dome spacing.

Contractor shall install reinforcement with welded steel wire fabric and shall be positioned as indicated on the Drawings or as hereinafter specified. Ramp runs longer than ten feet (10') in length shall be reinforced with welded steel wire fabric. No joints shall be placed within the ramp unless noted otherwise.

Contractor shall install and finish the P.C.C. in accordance with the Contract Documents prior to installation of the detectable warning panel(s). Contractor shall tamp the plate(s) or panel(s) with a small sledge hammer with a two inch by six inch by twenty inch (2" x 6" x 20") wood tamping plate, or lightly vibrate into the fresh concrete to ensure that the panel's field level (base of truncated dome) is flush with the adjacent concrete and top back of curb. Contractor shall ensure that the panel's field level is flush with the adjacent concrete surface, proper water drainage is provided, and potential tripping hazards are eliminated. Contractor shall ensure that the back edge of the detectable warning panel(s) form a smooth arc and is parallel to the top back of the curb.

Immediately after the panel placement, Contractor shall check and adjust accordingly the panel's or plate(s) field level to be flush with the adjacent concrete surface. Following final field-level adjustment(s), conforming to the manufacturer's recommendations, on each panel and additional weights at panel-to-panel joints as necessary to provide a solid contact between the panel underside and the concrete.

During and after the panel installation and concrete curing time, Contractor shall ensure that there is no walking, leaning, or any external forces placed on the panel, thereby causing a void between the underside of the panel and the concrete.

After the concrete has cured, Contractor shall remove protective plastic wraps. If "concrete bleeding" occurs between the panels, Contractor shall remove the residue without damage to the panel surfaces, in accordance with the manufacturer's recommendation.

Contractor shall maintain, on-site, an electronic level, a five foot (5') diameter circle template, and a three foot by five foot (3'x5') rectangular template. Template may be of any material, including paper. Contractor shall, when requested, demonstrate to the Engineer that there are adequate landing and turning areas that meet the dimensions and slopes required on the Drawings.

Backfill and grade areas disturbed by curb ramp construction and restore ground surface as shown on Drawings.

**Article 4.4 Tolerances**

In accordance with the Americans with Disabilities Act Public Rights-of-Way Accessibility Guidelines (PROWAG), dimension not stated as “maximum” or “minimum” are absolute. All dimensions are subject to conventional industry tolerances, except where the requirement is stated as a range with specific minimum and maximum end points.

Conventional industry tolerances recognized by the ADAAG include those for field conditions that may be a necessary consequence of a particular manufacturing process. Information on specific tolerances may be available from industry or trade organizations, code groups, building officials, and published references. (Example: American Concrete Institute Standard Specifications for tolerances for concrete construction and materials (ACI-117)).

**Article 4.5 Measurement**

The Work paid for under “P.C.C. Curb Ramp” shall be measured as furnished, constructed, finished, and accepted in place for each installation or the actual horizontal square yardage of curb ramp (including curb ramp under detectable warnings) and back curb.

The Work paid for under “Detectable Warnings” is measured by the actual horizontal square footage of detectable warning tiles furnished, installed, and accepted in place. When P.C.C. Curb Ramp is paid per each, the Detectable Warnings are incidental to each installation and no separate payment shall be made.

**Article 4.6 Basis of Payment**

Payment for this Work shall be in accordance with Division 10, Section 10.07 - Measurement and Payment, and shall include full payment for all Work described in this Section.

Payment for restoration of existing ground surface disturbed by curb ramp construction is made under “A.C. Pavement,” “P.C.C. Sidewalk,” “Topsoil,” and “Seeding,” as applicable. No separate payment is made for backfilling and grading in preparation of paid surface treatment. No separate payment is made for backfilling and grading in locations where the existing surface is gravel.

Payment shall be made under the following unit:

ITEM	UNIT
P.C.C. Curb Ramp (Type)	Each
P.C.C. Curb Ramp (Type)	Square Yard
Detectable Warnings	Square Foot

## **SECTION 30.05 STRUCTURES AND RETAINING WALLS**

### **Article 5.1 Description**

The Work under this Section consists of the construction of Portland Cement Concrete structures and retaining walls.

### **Article 5.2 Materials**

Portland Cement Concrete, joint filler, reinforcing steel, and curing materials shall conform to Section 30.01, Article 1.3 – Materials. Concrete mix shall conform to the requirements for Class AA-3 unless otherwise specified.

### **Article 5.3 Construction**

#### **A. Reinforcing Steel**

Reinforcing bars shall be bent cold and shall conform accurately to the shape and dimensions shown on the shop drawings. Bent-up bars, unless otherwise specified, shall be bent up at an angle of forty-five degrees (45°). In no case shall the radius of any bend be less than six (6) times the diameter of the bar except #3, 4, and 5 ties may be bent at five (5) times the diameter of the bar.

The reinforcement shall be positioned as indicated on the Drawings or as hereinafter specified. It shall be rigidly blocked and wired in place, using metal supports or concrete blocks and securely tied at each intersection with annealed iron wire of at least twelve (12) gauge.

Splicing bars at points not indicated on the Drawings will not be permitted except as an emergency measure and with the consent of the Engineer. Such splices shall be at the points of minimum tensile stress and the lap shall be not less than thirty-six (36) bar diameters.

Bar lists and Bending schedules shall be furnished by the Contractor for approval of the Engineer. Shop drawings shall be submitted to be approved by the Engineer. Materials shall not be ordered until such lists and bending diagrams have been approved by the Engineer. The approval of order lists and bending diagrams will in no way relieve the Contractor of responsibility for the correctness of such lists and diagrams. Any expense incidental to the revision of material furnished in accordance with such lists and diagrams, to make it comply with the design drawings, shall be borne by the Contractor.

#### **B. Forms**

Forms shall conform to the shape and dimensions shown on the Drawings and shall be accurately set to line and grade. All sheeting in contact with concrete surfaces shall be matched tongue and groove lumber, sized to uniform thickness and free from wane, warp, splits, loose knots or other defects which will prevent obtaining a smooth, tight form. Forms for exposed surfaces shall be lined with plywood conforming to the requirements for form plywood as specified by the American Plywood Association. All plywood lining shall be used in as wide pieces as possible. Areas less than four feet (4') in width shall be lined with a single width of plywood. Joints in lining and backing shall not occur at the same place and the



abutting edges of adjacent sheet shall be nailed to the same board. Re-used forms shall be cleaned and free from defects.

Joints in the lining shall be filled with cold water putty, patching plaster, plastic wood, or other plastic filler satisfactory to the Engineer. Lining material may be re-used if it is in satisfactory condition, well cleaned, re-oiled, and if specific permission from the Engineer is obtained for each separate operation.

All forms shall be securely tied with bolts, rods, or snap ties in such manner that after stripping, such bolts, rods, or snap ties may be either entirely removed or may be removed for a distance at least one inch (1") below the concrete surface. Such bolts or rods shall be threaded and provided with nuts to prevent slipping and to provide adjustments. No wire ties or clamping devices shall be permitted.

Forms for walls, etc., shall have large cleanout openings at their lowest points, which shall not be closed until just before placing concrete. All forms shall be thoroughly cleaned and soaked with water immediately before filling.

Weep drains shall be provided by the Contractor and installed as shown on the Drawings.

#### C. Placing

Concrete shall be placed by means of a bottom dumping bucket, cart, concrete chute, tremie, or concrete pump. At no time shall concrete have a free fall or more than three feet (3'). The concrete shall be brought up in approximately horizontal layers. The concrete shall be placed continuously from one side or end of the section to the other, using precautions to not put the full hydrostatic load upon any given area of form as rapidly as possible. The rate of delivery of concrete to the work shall be such as to insure continuity of placement. No partially completed surface shall be allowed to stand more than forty-five (45) minutes before continuing the placing of concrete thereon. If the time exceeds 45 minutes the joint shall be considered a cold joint and prepared as described in "Joints, Horizontal and Vertical".

#### D. Compacting Concrete

All concrete shall be thoroughly spaded, especially along the forms, to prevent the formation of gravel pockets and to permit the escape of trapped air. In addition to spading, the Contractor shall also provide suitable internal vibrating tampers of the type designed to be placed directly in the concrete. Vibration shall be such that the concrete becomes uniformly plastic. Vibrators shall be inserted to a depth sufficient to vibrate the bottom of each layer effectively, but shall not be allowed to penetrate partially hardened concrete which will not become plastic under the vibrator action, nor shall the vibrator be applied directly to steel which extends into partially hardened concrete. Placing of concrete shall not commence until the vibrator is on the job site and the mechanical efficiency of the vibrator is proven in the presence of the Engineer. For critical structures a spare vibrator shall be available at the site.

#### E. Finishing Concrete

All irregularities such as gravel pockets, bolt holes, etc., shall be patched with mortar of the same proportions as used in the concrete. The surface film of all such patches shall be rubbed off after initial setting has taken place.

All exposed surfaces shall, after irregularities have been corrected, be thoroughly wetted and brushed with a grout composed of one (1) part fine sand and one (1) part cement. It shall then be kept wet for forty-eight (48) hours.

All outside edges are to have three-quarter inch (3/4") chamfered corners, unless noted otherwise. They shall be obtained by putting a triangular strip of wood in the corners of the forms.

#### F. Joints, Horizontal and Vertical

Joints shall be made in walls or structures as indicated on the Drawings or where directed by the Engineer. If not indicated on the Drawings, the maximum distance between contraction joints shall be twenty-five feet (25'), and the maximum distance between expansion joints shall be fifty feet (50'). Where expansion joints are required, one-half inch (1/2") precast expansion joint material conforming to the requirements of ASTM D1751 (AASHTO M 213) shall be used. The walls shall be poured one section at a time. The joint material shall be accurately cut to fit the bulkhead between sections, and nailed to the bulkhead with 6d nails. These nails shall be driven into the lumber only enough to hold the material in place, the heads being embedded in the concrete. The bulkheads between sections shall be removed not sooner than twelve (12) hours after the concrete has been placed and the nail points clinched into the joint material.

At the surface of the wall, unless otherwise shown, the joint shall end in a V-shaped groove, two inches (2") wide and one inch (1") deep. Unless noted otherwise, all joints will be truly horizontal or truly vertical. Prior to placing fresh concrete, construction joints shall be roughened to one-quarter inch (1/4") amplitude, cleaned and wetted.

#### G. Removal of Forms

Unless otherwise directed by the Engineer, forms may be removed from structures and retaining walls, which are not subject to supporting loads, after a period of twenty-four (24) hours. All other forms shall be removed upon approval of the Engineer.

#### H. Curing

Unless otherwise specified, all exposed surfaces shall be covered by layers of absorptive burlap, mats or other approved material to a thickness weighing not less than fourteen (14) ounces per square yard, immediately after finishing. The cover material shall be kept saturated with clean water for a minimum initial curing period of twenty-four (24) hours.

Following this initial curing, the concrete shall be completely covered with a plastic waterproof membrane, or equal, for an additional six (6) days. Liquid spray type waterproof membrane will not be considered a satisfactory material for curing concrete used for retaining walls or structures.

If ambient temperatures are expected to drop below forty degrees (40°) Fahrenheit, the Contractor shall provide a cold weather curing plan and provide protection to meet ACI recommendations.

I. Waterproofing

Unless otherwise specified, the back side of retaining walls and backfilled surfaces of other structures shall be painted with two (2) coats of a cold bituminous waterproof coating which shall be approved by the Engineer prior to application. Application shall be with a stiff masonry type brush, or as recommended by the manufacturer.

J. Earthwork

All earthwork involved in the construction of retaining walls shall be constructed as specified in Division 20 - Earthwork.

Excavation for retaining walls and structures shall be to the limits shown on the Drawings. Where limits are not indicated, excavation shall be sufficient to properly construct the work.

Where directed by the Engineer, unsuitable material in the subgrade shall be removed to a specific depth and then backfilled with classified fill.

The subbase under footings shall be compacted to ninety-five percent (95%) density at optimum moisture content in accordance with Section 30.01, Article 1.5 - Subbase.

Backfilling the lower portion of structures and retaining walls shall not begin until lab testing of field-cured specimens has attained at least 80 percent of the Specified Compressive Strength after concrete placement. Where High-Early Strength Cement is used, backfilling the lower portion of structures and retaining wall shall not begin until four (4) days after concrete placement. Waterproofing shall not be left exposed for longer than twelve (12) days before backfill. Where drain holes or drain tile are involved, or where the Engineer may direct, a filter fabric shall be used in conjunction with a six inch (6") layer of coarse gravel which shall be spread and compacted around the drains in such a manner that earth will not clog the voids in the gravel. The remainder of the backfill shall be classified fill placed in layers not exceeding one foot (1') in thickness. Each layer shall be thoroughly rammed with a rammer not more than ten inches (10") in diameter and weighing not less than forty (40) pounds, or with an approved mechanical tamper. A Controlled Low Strength Material (CLSM) used as a substitution to backfill shall be a flowable sand/cement mix with a compressive strength of 500 psi to 1,000 psi and shall be allowed with the approval of the Engineer. Unsuitable earth or vegetable matter shall not be used as backfill. Filling with loose earth and hydraulic jetting will not be allowed except by written permission of the Engineer. Imported material for backfill shall conform to Division 20, Section 20.21 - Classified Fill and Backfill.

K. Concrete walls shall include an anti-graffiti coating. Anti-graffiti coating shall be Sherwin Williams Protective & Marine Coatings, Series B97-150, or accepted equal. Anti-graffiti coating shall be applied per manufacturer's recommendations.

**Article 5.4 Measurement**

Concrete shall be measured per cubic yard for structures and retaining walls including sidewalks constructed in conjunction with retaining walls. Measurement will be determined from the neat line dimension. In the case of minor field changes such a changing the length, height, etc., payment shall be based on the same unit price per cubic yard as bid. Measurement shall be determined by the Engineer and Contractor prior to placing concrete.

Graffiti protection is incidental to the construction of the structures and retaining walls and no separate payment shall be made.

**Article 5.5 Basis of Payment**

Payment for this Work shall be in accordance with Division 10, Section 10.07 - Measurement and Payment, and shall include full payment for all Work described in this Section. Extra payment will not be made to the Contractor if he places additional concrete over and above the neat line volume to facilitate his operation and save on form work.

No additional payment shall be made for excavation and backfill around retaining walls and structures. Payment for disposal of unusable excavation shall be in accordance with Division 20, Section 20.10 – Excavation for Traffic Ways. Payment for classified fill shall be made in accordance with Division 20, Section 20.21 – Classified Fill and Backfill.

Payment shall be made under the following unit:

ITEM	UNIT
P.C.C. Structure/Retaining Wall (Class)	Cubic Yard

## **SECTION 30.06 CONCRETE MASONRY RETAINING WALLS**

### **Article 6.1 Description**

The Work covered under this Section consists of the construction of concrete masonry walls on a reinforced, poured Portland Cement Concrete footing. This Work includes all excavation, classified fill or backfill, and mechanical compaction.

### **Article 6.2 Materials**

Portland Cement Concrete, joint filler, reinforcing steel, and curing materials shall conform to Section 30.01, Article 1.3 – Materials. Concrete mix shall conform to the requirements for Class AA-3 unless otherwise specified.

### **Article 6.3 Construction**

#### **A. Reinforcing Steel**

Reinforcing steel shall conform to Section 30.05, Article 5.2 - Construction.

#### **B. Survey**

The Contractor shall set control stakes for the footings. The stakes will be set at breaks in grade and on even grade intervals not to exceed fifty feet (50'). They will be marked with the station offset, and the cut or fill to the top of the footing.

#### **C. Forms**

Forms may be of wood, metal, or any other material at the option of the Contractor, provided that the forms as set will result in a footing in accordance with thickness, cross section, grade, and alignment as required by the Contract Documents.

Forms may be removed after a period of three (3) days, unless otherwise directed by the Engineer.

#### **D. Excavation and Embankment**

Excavation and embankment for Masonry Retaining Walls shall be as described in Section 30.05, Article 5.2, SubArticle J - Earthwork.

#### **E. Constructing Masonry Wall**

The Contractor shall omit the head joint in the first course every thirty-two inches (32") O.C. to provide for weep holes.

All cells of the concrete masonry retaining wall shall be filled solid with grout. The grout shall develop a maximum compressive strength of 2,000 P.S.I. in 28 days. The grout mix shall be of a fluid consistency and mixed in the ratio by volume of one (1) part Portland cement, three (3) parts concrete sand, and two (2) parts No. 8 Coarse Aggregate. The concrete sand is to conform to the gradation requirements of AASHTO M 6. The coarse aggregate is to comply with gradation requirements as follows:

#### **Coarse Aggregate Gradation Requirements**

<b>Sieve Size</b>	<b>Percent Passing by Weight</b>
1/2"	100

3/8"	85-100
#4	10-30
#8	0-10
#16	0-5

Mortar shall be freshly prepared and uniformly mixed in the ratio by volume of one (1) part cement, one-half (1/2) part lime putty, and four and one-half (4-1/2) parts sand and shall conform to requirements of ASTM C270.

The use of admixtures shall not be permitted in mortar or grout unless substantiating data is submitted and approved by the Engineer.

Masonry units shall be Grade A Units, conforming to the requirements of ASTM C90. These units shall be sound, dry, clean, and free from cracks when placed in the structure. Where masonry unit cutting is necessary, all cuts shall be neat and true. Unit size and surface finish shall be as indicated on the Drawings.

Portland Cement Concrete used in footings, shall conform to Section 30.01, Article 1.3 - Materials.

Block layup shall be running bond unless otherwise specified.

The starting joint on the footing shall be laid with full mortar coverage on the bed joint. All mortar joints shall be straight, clean and uniform in thickness and shall be tooled.

Tooling shall be done with a round bar to produce a dense, slightly concave surface well bonded to the block at the edges. Tooling shall be done when the mortar is partially set but still sufficiently plastic to bond. All tooling shall be done with a tool which compacts the mortar, pressing the excess mortar out of the joint rather than dragging it out. Joints which are not tight at the time of tooling shall be raked out, pointed, and then tooled.

If it is necessary to move a unit after it has been set in place, the unit shall be removed from the wall, cleaned and set in fresh mortar.

All capping units shall be set in a full bed of mortar.

**F. Curing and Waterproofing**

Curing and waterproofing of concrete masonry retaining walls shall conform to the specifications for structures and retaining walls in Section 30.05, Article 5.2, SubArticles H - Curing, and I - Waterproofing.

**Article 6.4 Measurement**

The item concrete masonry retaining walls shall be on a lump sum basis, complete in place and no measurement of quantities shall be made.

**Article 6.5 Basis of Payment**

Payment for this Work shall be in accordance with Division 10, Section 10.07 - Measurement and Payment, and shall include full payment for all Work described in this Section.

Payment shall be made under the following unit:

ITEM

Concrete Masonry Retaining Walls

UNIT

Lump Sum

## **SECTION 30.07 PORTLAND CEMENT CONCRETE DRIVEWAY**

### **Article 7.1 General**

The Work under this Section consists of performing all operations pertaining to furnishing and constructing a Portland Cement Concrete driveway.

### **Article 7.2 Materials**

Portland Cement Concrete, joint filler, and curing materials shall conform to Section 30.01, Article 1.3 – Materials. Concrete mix shall conform to the requirements for Class AA-3 unless otherwise specified.

### **Article 7.3 Construction**

Contractor shall place concrete surfacing at a thickness of six inches (6"). Concrete driveways shall have a minimum six by six inch (6" x 6") woven wire mesh reinforcement installed.

### **Article 7.4 Measurement**

Concrete driveways shall be measured per square yard, complete in place, for six inch (6") thicknesses.

### **Article 7.5 Basis of Payment**

Payment for this item shall be in accordance with Division 10, Section 10.07 – Measurement and Payment, and shall include full payment for all Work described in this Section.

Payment shall be made under the following unit:

ITEM	UNIT
P.C.C. Driveway	Square Yard



## **SECTION 30.08 PORTLAND CEMENT CONCRETE CLUSTER MAILBOX BASE**

### **Article 8.1 General**

The Work under this Section consists of performing all operations pertaining to furnishing and constructing a Portland Cement Concrete cluster mailbox base.

### **Article 8.2 Materials and Installation**

Each cluster mailbox base shall be constructed in conformance with the Drawings. Materials and installation shall meet the requirements of Section 30.03 - Portland Cement Sidewalks and the Drawings. Concrete mix shall conform to the requirements for Class AA-3 unless otherwise specified.

Post installed anchors shall be stainless steel rods with adhesive installed per the adhesive manufacturer's instructions.

### **Article 8.3 Construction**

Contractor shall contact the Manager of the Address Management Department, Anchorage District, United State Post Office at 564-2846, forty-eight (48) hours prior to beginning construction of the cluster mailbox base to schedule the final placement of the cluster mailbox unit by the United State Post Office.

### **Article 8.4 Measurement**

The Work shall be measured per each actual cluster mailbox base furnished, constructed, and accepted in place.

### **Article 8.5 Basis of Payment**

Payment for this Work shall be in accordance with Division 10, Section 10.07 - Measurement and Payment and shall include full payment for all Work described in this Section.

Payment shall be made under the following unit:

ITEM	UNIT
P.C.C. Cluster Mailbox Base	Each

## **SECTION 30.09 CONCRETE PARKING BUMPERS**

### **Article 9.1 Description**

This Work item includes the forming, casting, and installation of concrete parking bumpers as shown on the Drawings.

### **Article 9.2 Material**

Reference Section 30.01 - General Provisions.

Concrete class shall be AA-3.

### **Article 9.3 Construction**

Contractor shall construct precast concrete parking bumpers in accordance with applicable construction techniques specified in Section 30.02 - Portland Cement Concrete Curb and Gutter, and Valley Gutter. Parking bumpers shall be seven feet (7') long and seven inches (7") tall. Parking bumpers shall be ten inches (10") wide at the base and taper to six inches (6") wide at the top. Parking bumpers shall be firmly set in place with two (2) eighteen inch (18") long #5 rebar.

### **Article 9.4 Basis of Payment**

Payment for this Work shall be in accordance with Division 10, Section 10.07 - Measurement and Payment, and shall include full payment for all Work described in this Section.

Payment will be made under the following unit:

ITEM	UNIT
Concrete Parking Bumpers	Each

## **SECTION 30.10 COLORED CONCRETE**

### **Article 10.1 General**

The Work under this Section consists of providing all operations and materials necessary to install colored concrete. All Work shall be in accordance with this Section and shall be placed at the locations shown on the Drawings.

### **Article 10.2 Materials**

The Portland Cement concrete and curing materials shall conform to Section 30.01, Article 1.3 - Materials, as modified below:

#### **A. Concrete**

Concrete mix for imprinted colored concrete shall conform to Section 30.01, Article 1.6 – Mix Requirements for Classes of Concrete, requirements for Class AA-3, normal weight concrete. Contractor shall make white concrete using white cement, white aggregate, and white sand. Contractor shall use Davis Color #160, Brick Red, available from Davis Color, Los Angeles, California or approved equal, at a rate of 5 pounds of color per sack of cement to make colored concrete.

#### **B. Imprint**

Where imprinted concrete is called for on the Drawings, the Contractor shall use “Bomanite Running Bond Tile” available from Bomanite Corporation, Palo Alto, California, or another concrete imprinting system of approved equal performance.

#### **C. Expansion Joints**

Filler material shall be non-asphaltic material, one-half inch (1/2") wide and four inches (4") deep, with the top one inch (1") strippable. Primer shall be “Externaflex” 1993 or approved equal. Backer rod shall be closed cell polyethylene. Sealant shall be “Sika-Flex” polyurethane or approved equal. Contractor shall use the appropriate sealant color to match the colored concrete, including Brick Red sealant to match the red concrete.

### **Article 10.3 Construction**

The excavation and embankment, forms and fine grading, placing and finishing, curing and protection operations for imprinted colored concrete shall conform to Section 30.03, Article 3.3 – Construction as amended below:

Place imprinted colored concrete in dry weather with temperatures above forty degrees (40°) Fahrenheit.

Where imprinted concrete is called for in the Drawings, the Contractor shall apply the imprinting tool while the concrete is still in the plastic stage of set in conformance with the manufacturer’s specifications.

### **Article 10.4 Measurement**

Imprinted colored concrete shall be measured per square yard, complete and in place.

**Article 10.5 Basis of Payment**

Payment for this Work shall be in accordance with Division 10, Section 10.07 - Measurement and Payment and shall include full payment for all Work described in this Section.

Payment shall be made under the following unit:

ITEM	UNIT
Colored Concrete (Color) (Thickness) (Imprinted)	Square Yard

## **SECTION 30.11    SIDEWALK JOINT SEALANT**

### **Article 11.1 General**

The Work under this Section consists of performing all operations pertaining to preparing and sealing joints in existing sidewalk for the purposes of sealing and repair. This Section is not applicable to joint sealant utilized during the construction of new concrete work.

### **Article 11.2 Materials**

Sealant materials shall be a polyurethane or a hot applied asphalt-based long lasting, and resist deterioration caused by weather, street, movement, traffic, and water. Sealant materials shall be approved by the Engineer prior to use. The sealant color shall closely match adjacent concrete sidewalk.

### **Article 11.3 Construction**

Joint sealant shall be applied to joints with dimensions between one-half inch (1/2") and one inch (1") in width, as directed by the Engineer. The sealant shall be applied in conformance with the manufacturer's instructions and to full depth of the joint.

The joints shall be cleaned and all loose material shall be blown out to the full depth of the joint. The interior of the joint shall be completely dried and existing sidewalk surfaces shall be exposed.

### **Article 11.4 Measurement**

The application of joint sealant shall be measured per linear foot of sealant applied as directed by the Engineer for sidewalk patch and repair. Payment for joint sealant used during construction of new concrete work is governed by the appropriate Section for that installation, is considered incidental to that pay item, and no payment shall be made under this Section.

### **Article 11.5 Basis of Payment**

Payment for this Work shall be in accordance with Division 10, Section 10.07 - Measurement and Payment and shall include full payment for all Work described in this Section.

Payment shall be made under the following unit:

ITEM	UNIT
Joint Sealant	Linear Foot

## **SECTION 30.12 HIGH-PERFORMANCE CONCRETE**

### **Article 12.1 General**

The Work under this Section consists of providing all operations, materials, and labor necessary to install high-performance concrete in accordance with these Specification at the locations shown on the Drawings or as directed by the Engineer. The concrete shall be reinforced and colored per the Drawings.

The concrete shall be a special high-performance design intended to have the following special characteristics:

- increased strength and durability
- increased resistance to spalling and freeze/thaw cycles
- increased workability during placement
- decorative color (when specified)

The high-performance concrete shall be a redi-mix concrete in conformance with M.A.S.S. Section 30.01 General.

### **Article 12.2 Materials**

The Portland Cement concrete, joint filler, reinforcement steel, and curing materials shall conform to Section 30.01, Article 1.3 – Materials, as modified below:

#### **A. Cement**

The cement shall be Type I/II in accordance with ASTM C150. Only one brand of cement shall be used for the high-performance concrete to minimize variations in overall appearance.

#### **B. Aggregates**

The aggregates shall meet the requirements of ASTM C33.

#### **C. Admixtures**

All admixtures shall be added to the concrete mix at the manufacturing plant. The following admixtures shall be used in the concrete mix:

1. Viscosity modifying admixture – The admixture shall be designed to produce concrete with enhanced viscosity and stability and increased resistance to segregation to facilitate placement and consolidation. The admixture shall be Rheomac VMA 362 as manufactured by BASF or approved equal.
2. Silica fume – The admixture shall be designed to produce extremely strong durable concrete meeting the requirements of ASTM C1240. The admixture shall be Rheomac SF 100 as manufactured by BASF or approved equal.
3. High-range water-reducing admixture – The admixture shall be designed to create a concrete with a slump as specified free from segregation and with relatively low water/cement ratio. The admixture shall be Rheobuild 1000 as manufactured by BASF or approved equal.

4. Air entraining admixture – The admixture shall be in accordance with ASTM C231 (AASHTO T 152).

#### D. Coloring Materials

Coloring shall be integral for the full depth of the concrete. It shall be added at the redi-mix concrete manufacturer plant per the manufacturer's instructions and uniformly distributed throughout the mix.

The concrete shall be provided with integral color pigment as follows:

- Davis Color #160, Brick Red, as manufactured by Davis Color, Los Angeles, California or approved equal, at a rate of 5 pounds of color per sack of standard grey cement, with standard grey sand and standard grey aggregate to make colored concrete.

#### E. Expansion Joints

Filler material shall be non-asphaltic material, one-half inch (1/2") wide and four inches (4") deep, with the top one inch (1") strippable. Primer shall be "Sika-flex" polyurethane or approved equal. Contractor shall use the appropriate sealant color to match the colored concrete, including Brick Red sealant to match the red concrete.

#### F. Evaporation Reducer

An evaporation reducer shall be used to reduce surface moisture evaporation and reduce plastic shrinkage cracking. The material shall be Confilm as manufactured by BASF or approved equal applied in accordance with the manufacturer's recommendations. The product should not be considered a finishing aid.

### **Article 12.3 Mix Requirements**

Below are general mix requirements for high-performance concrete:

Property	Value
Cement (sacks/CY) min	7.0
Water Content Ration (Gal./sac) max	0.35
Slump (inches)	3-5
Entrained Air (%)	4-6
Silica Fume (% of cement material)	5-8
Coarse Aggregate (ASTM C33)	Grade 67
Medium Aggregate (ASTM C33)	Grade 8
Fine Aggregate (ASTM C33)	Concrete Sand
Integral Color	As Required
Viscosity Modifying Admixture	As Required
High-Range Water-Reducing Admixture	As Required

The concrete shall have the following minimum compressive strengths as tested in accordance with AASHTO T 141:

Cure Time (days)	Minimum Compressive Strength (psi)
1	2,500
3	3,500
7	4,500
28	7,000

A detailed mix design shall be submitted to the Engineer for approval with the following information:

1. Design designation for which the substitution is intended.
2. Design strength.
3. Air Content.
4. Slump.
5. Aggregate gradation and maximum size.
6. Maximum water/cement content.
7. Minimum cement content.
8. List of admixtures, strength overdesign, and other special features.
9. Fine aggregate weight/percent moisture of fine aggregate.
10. Intermediate aggregate weight/percent moisture of intermediate aggregate.
11. Coarse aggregate weight/percent moisture of coarse aggregate.
12. Weight of cement.



- 13. Weight of water.
- 14. Unit weight.

Water shall not be used to increase slump. If additional slump is desired, additional plasticizing agent shall be used.

#### **Article 12.4 Mock-up Sample**

A mock-up sample of the concrete shall be provided at an off-site location as directed by the Engineer. The area shall be at least 4 feet square and 4 inches thick. The sample slab shall be used to test the acceptability of the overall mix design, workability, release agents, finish, colors, curing methods, and overall appearance. Mock-up samples that do not result in the required surface pattern or do not meet minimum strength requirements will be rejected. The Engineer may require the Contractor to provide additional samples if the sample is unacceptable.

Concrete samples for test cylinders shall be taken for each mock-up concrete mix in accordance with AASHTO T 141. Testing and sampling shall be performed by the Engineer. Compressive testing shall be made at the intervals listed in the table in Article 12.3.

The mock-up samples shall be constructed at least 10 days before the planned installation of the final concrete slab. The final concrete slab shall not be installed before the Engineer approves the mock-up samples.

#### **Article 12.5 Construction**

##### **A. Concrete Placement**

High-performance concrete shall be placed to the lines and grades shown on the Drawings as verified by Contractor in the field. Contractor shall remove and replace concrete not installed in accordance with the Drawings and Specification at no additional cost to the owner.

##### **B. Reinforcing Steel**

The reinforcement shall be positioned as indicated on the Drawings or as hereinafter specified. It shall be rigidly blocked and wired in place, using metal supports or concrete blocks and securely tied at each intersection with annealed iron wire of at least twelve (12) gauge.

##### **C. Evaporation Reducer**

An evaporation reducer shall be applied to the surface of the concrete while it is in the plastic state before the finishing phase. The product should not be considered a finishing aid. It shall be applied in accordance with the manufacture's recommendations and it shall not be allowed to remain on the surface of hardened concrete.

##### **D. Finishing Phase**

The finishing operations should not begin until the water sheen on the surface is one and excess bleed water on the surface has had a chance to evaporate. If this excess water is worked into the concrete because the finishing operations are begun too soon, the concrete on the surface will have too high a water content and will be weaker and less durable. Special care shall be taken to make sure that concrete is not overworked

while finishing which can result in discolorations and fewer aggregates near the surface resulting in a less durable material.

#### E. Broom Finish

After final finishing of the concrete surface with wood and steel floats, the surface shall be rushed with a fiber hair brush. The brushing shall be performed transverse to the predominant direction of pedestrian travel. The resulting surface shall be smooth with a linear texture resulting in a slip-resistant surface.

#### F. Curing

After finishing has been completed, provide a moist-cure topping to attain the proper design strength, surface impermeability, and wear resistance without cracking. Mist spray the surface with water and cover it with weighted polyethylene sheeting for a minimum of 7 days. When mist spraying is not possible, use soaker hoses with burlap or 2 layers of saturated burlap (or similar moisture-retaining sheet material) and cover surface with polyethylene for 7 days.

#### G. Protection

All vehicular/pedestrian traffic shall be kept off the concrete slab for the entire cure period. Concrete shall be protected against damage or defacement of any kind until it has been accepted by the Owner. Concrete which is not acceptable to the Engineer because of damage or defacement shall be removed and replaced at no additional cost to the Owner.

### **Article 12.6 Measurement**

High-performance concrete slab shall be measured per square yard, complete and accepted in place in the specified thickness, color, and surface finish. There shall be no separate measurement or payment for subbase preparation, samples, mockups, forms, reinforcing steel, dowels, joints, concrete mix, pigment, finishing, curing or protection as they will be considered incidental to this Work item.

### **Article 12.7 Basis of Payment**

Payment for this Work shall be in accordance with Division 10, Section 10.07 - Measurement and Payment as amended in these specifications and shall include full payment for all Work described in this Section.

Payment shall be made under the following units:

ITEM	UNIT
High-Performance Concrete (Thickness, Color, Finish)	Square Yard

**MUNICIPALITY OF ANCHORAGE  
STANDARD SPECIFICATIONS**

**DIVISION 30  
PORTLAND CEMENT CONCRETE  
STANDARD DETAILS**

**STANDARD CONSTRUCTION SPECIFICATIONS  
DIVISION 30  
INDEX OF STANDARD DETAILS**

30-1	Curb and Gutter Cross Sections
30-2	Curb and Gutter Termination Transition
30-3	Valley Gutter
30-4	Median/Curb Nose
30-5	Steel Curb Facing
30-6	Driveway Curb-cut with Attached Sidewalk
30-7	Driveway Curb Return with Attached Sidewalk
30-8	Curb Ramp Notes
30-9	Perpendicular Curb Ramp
30-10	Parallel Curb Ramp
30-11	Blended Transition Curb Ramp
30-12	Unidirectional Curb Ramp
30-13	Accessible Curb and Gutter Sections
30-14	Curb Ramp Clearances
30-15	Pedestrian Push Button Access
30-16	Curb Type Retaining Wall - 2' to 3'
30-17	Sidewalk Retaining Wall - 6" to 24"
30-18	Sidewalk Retaining Wall - 2' to 5'
30-19	P.C.C. Cluster Mailbox Base

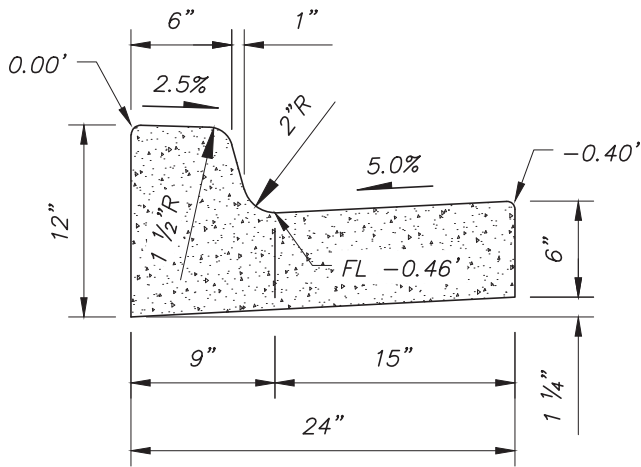

TYPE 1

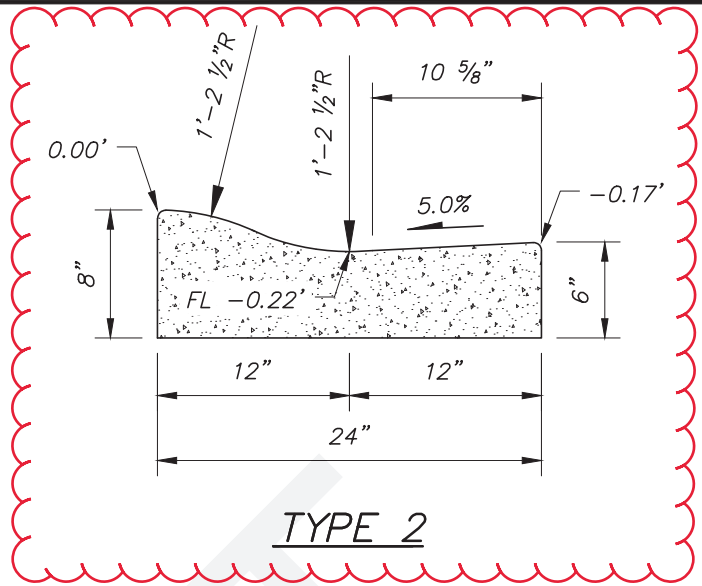

TYPE 2

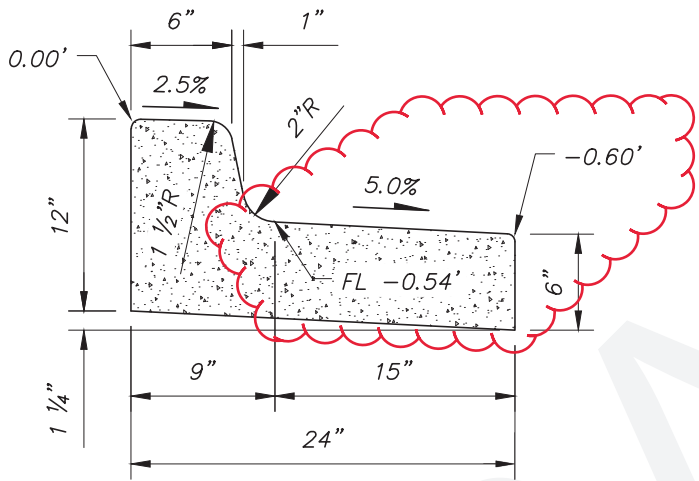

TYPE 3

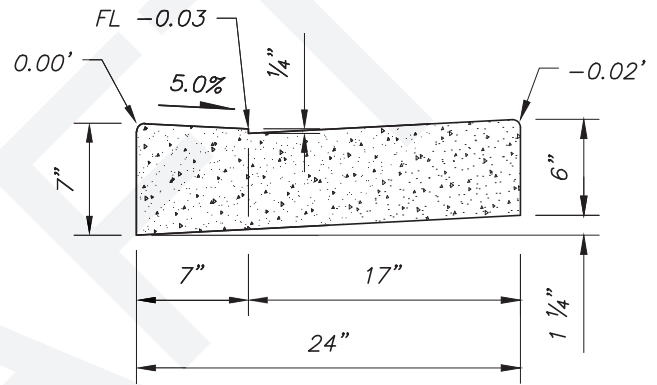

TYPE 4  
(USED AT CURB CUTS)

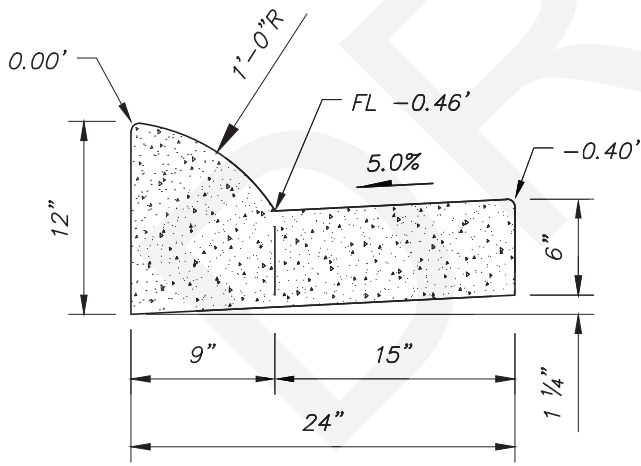

TYPE 5

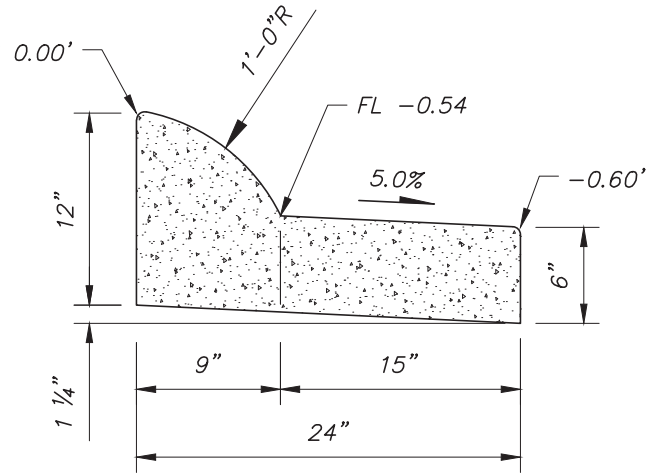

TYPE 6

NOTE:

1. TROWEL BOTH FRONT AND BACK EDGES OF THE CURB & GUTTER TO A RADIUS OF ONE-HALF (1/2) INCH.

REVISION: 2024 M.A.S.S. UPDATE



SCALE:  
N.T.S.

APPROVED:

REVISED:  
10/23

# CURB AND GUTTER CROSS SECTIONS

SECTION #  
30.02

DETAIL #  
30-1

REVISION: 2024 M.A.S.S. UPDATE

0.5"  
EXPANSION  
JOINT

LIMITS OF PAVING

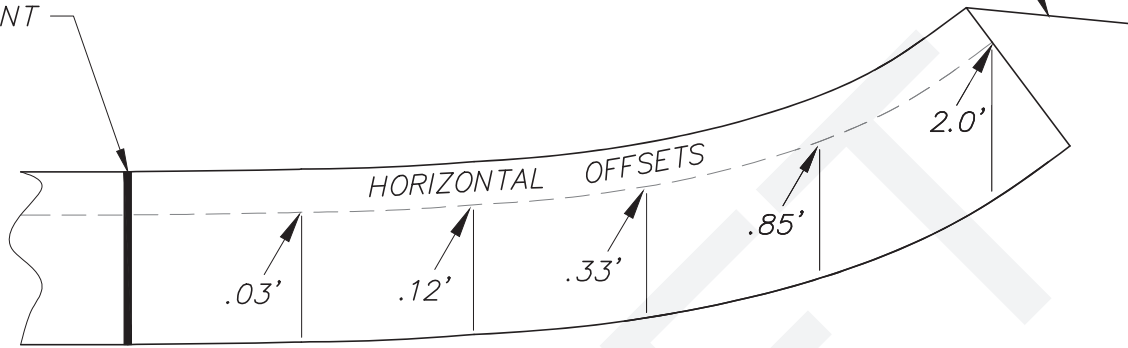

PLAN

0.5"  
EXPANSION  
JOINT

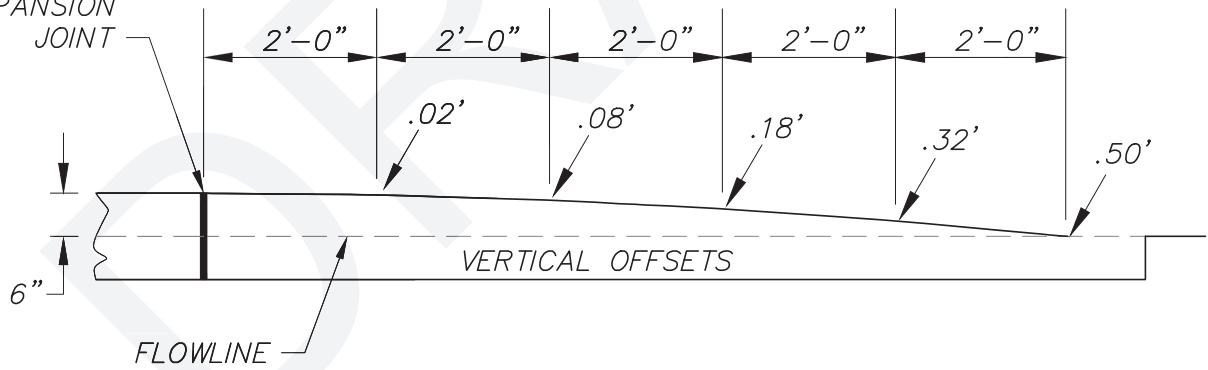

PROFILE

MUNICIPALITY



OF ANCHORAGE

SCALE:  
N.T.S.

APPROVED:

REVISED:  
10/23

# CURB AND GUTTER TERMINATION TRANSITION

SECTION #  
30.02

DETAIL #  
30-2

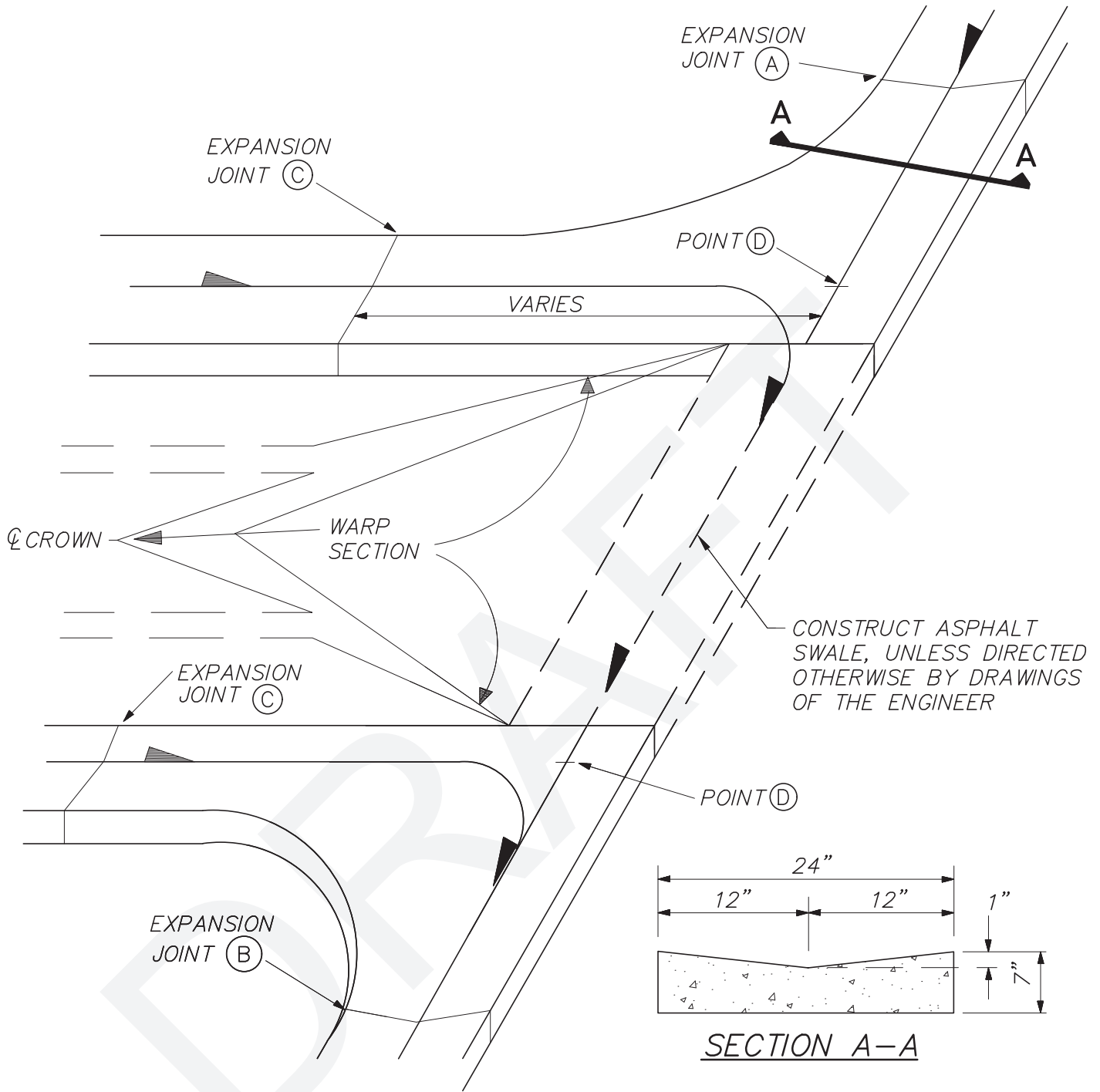

NOTE:

VALLEY GUTTER SHALL BE PAID PER LINEAR FOOT UNDER BID ITEM "VALLEY GUTTER". MEASURE LENGTHS ALONG THE STRAIGHT FLOW LINE FROM EXPANSION JOINTS "A" AND "B" TO POINT "D" AND ON BOTH SIDES FROM EXPANSION JOINT "C" TO THE POINT "D". THE STREET SECTION SHALL BE MEASURED FROM POINT "D" TO POINT "D". IF P.C.C., THE STREET SECTION SHALL BE INCLUDED UNDER BID ITEM "VALLEY GUTTER". IF ASPHALT, THE STREET SECTION COST SHALL BE INCLUDED UNDER THE APPROPRIATE PAVING BID ITEM.

REVISION: 2024 M.A.S.S. UPDATE



SCALE:  
N.T.S.

APPROVED:

REVISED:  
10/23

**VALLEY GUTTER**

SECTION #  
30.02

DETAIL #  
30-3

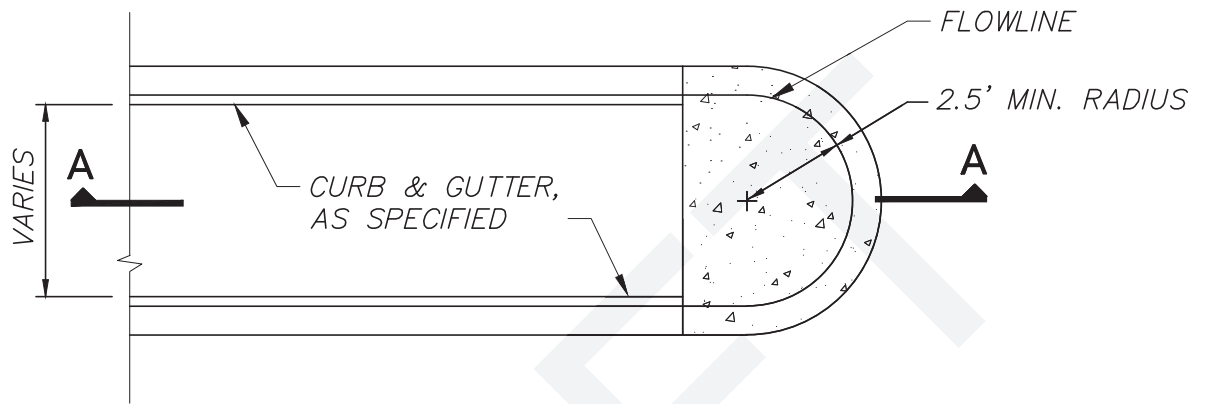

PLAN VIEW

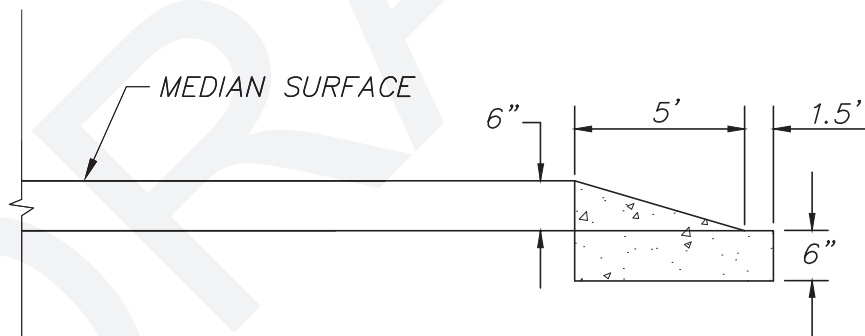

SECTION A-A

REVISION: 2024 M.A.S.S. UPDATE

MUNICIPALITY



OF ANCHORAGE

SCALE:  
N.T.S.

APPROVED:

REVISED:  
10/23

# MEDIAN/CURB NOSE

SECTION #  
30.02

DETAIL #  
30-4



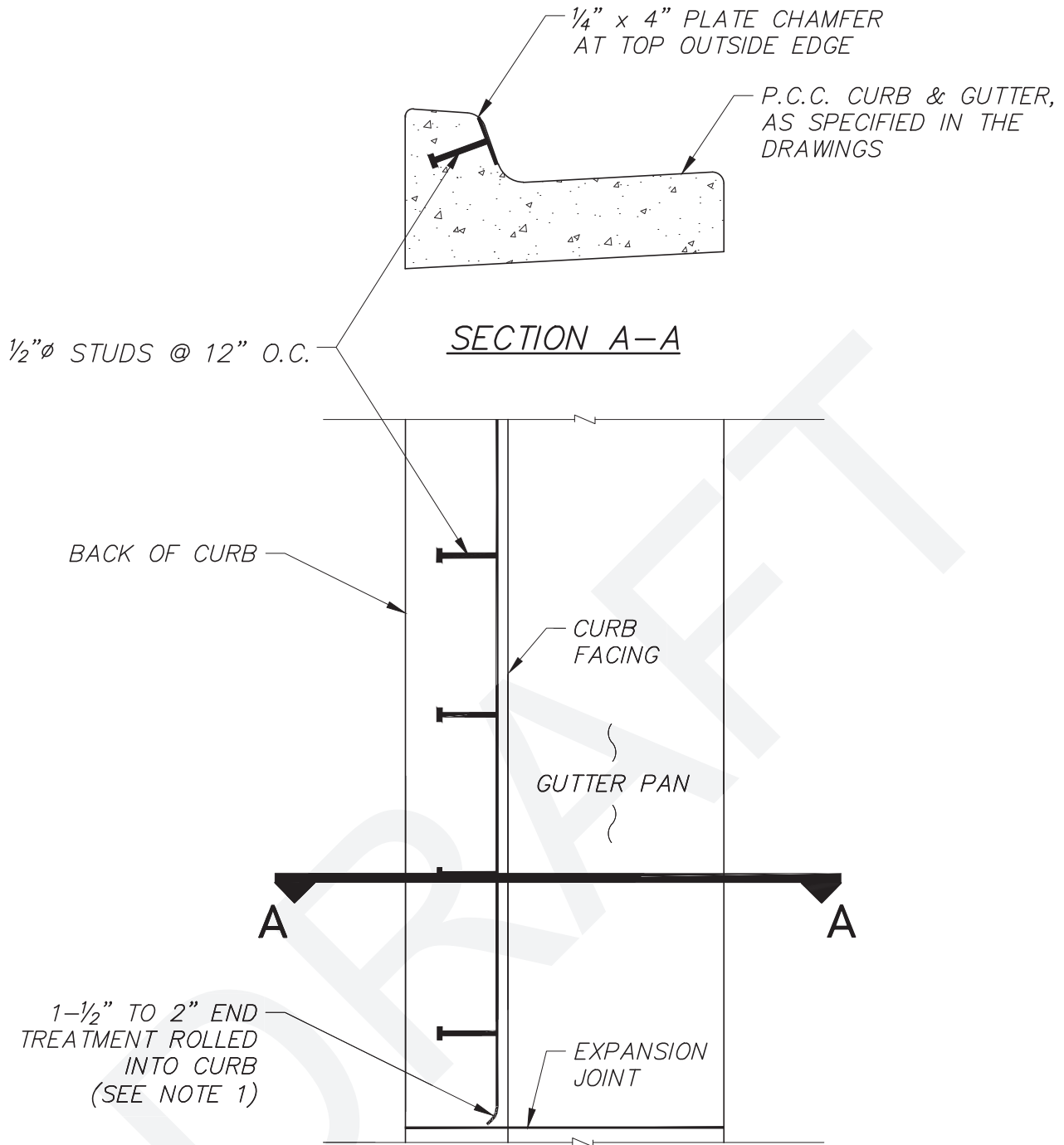

NOTES:

1. BEND LEADING AND TRAILING EDGES 90° AND EMBED IN 1- $\frac{1}{2}$ " MINIMUM CONCRETE.
2. STEEL CURB FACING SHALL BE INSTALLED ONLY IN LOCATIONS WHERE THERE IS A CURVILINEAR TRANSITION TO THE CURB FACE SUCH AS IN A CURB BULB OR TRANSIT PULL-OUT.
3. CONTRACTOR SHALL INSTALL STEEL CURB FACING SO THAT THE CHAMFERED EDGE IS FLUSH WITH THE TOP OF CURB.

REVISION: 2024 M.A.S.S. UPDATE

MUNICIPALITY



OF ANCHORAGE

SCALE:  
N.T.S.

APPROVED:

REVISED:  
10/23

## CURB AND GUTTER WITH STEEL CURB FACING

SECTION #  
30.02

DETAIL #  
30-5

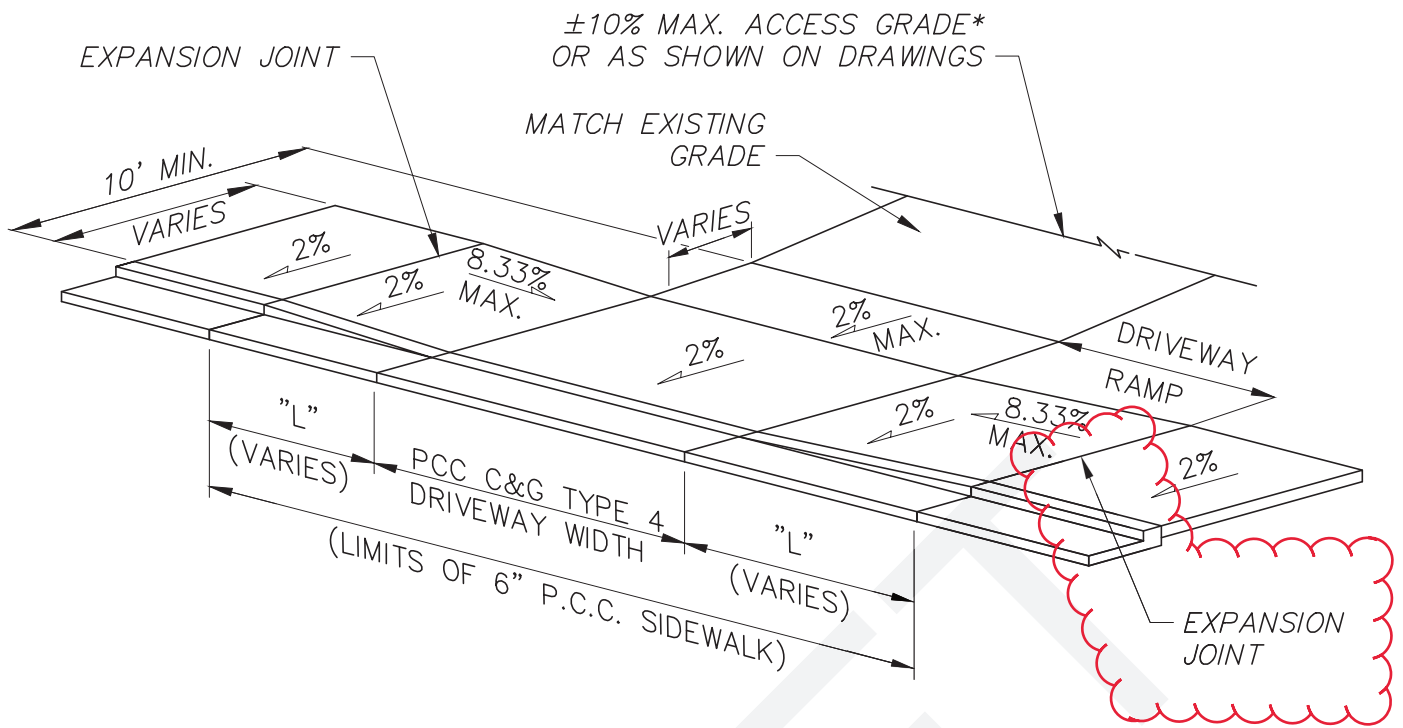

**TYPICAL DRIVEWAY ENTRANCE  
(WITH ATTACHED SIDEWALK)**

DRIVEWAY RAMP RUNNING SLOPE TABLE		
STREET RUNNING SLOPE	MINIMUM UPHILL RAMP LENGTH "L"	MINIMUM DOWNHILL RAMP LENGTH "L"
0.0% TO 0.5%	6.0'	6.0'
> 0.5% TO 1.6%	7.0'	6.0'
> 1.6% TO 2.4%	8.0'	5.0'
> 2.4% TO 3.1%	9.0'	5.0'
> 3.1% TO 3.6%	10.0'	5.0'
> 3.6% TO 4.0%	11.0'	4.0'
> 4.0% TO 4.4%	12.0'	4.0'
> 4.4% TO 4.7%	13.0'	4.0'
> 4.7% TO 5.0%	14.0'	4.0'
> 5.0%	15.0'	4.0'

\* MAXIMUM ALGEBRAIC DIFFERENCE IS 8% ON COMMERCIAL/INDUSTRIAL DRIVEWAYS.

**NOTE:**

1. THE CURB TRANSITION LENGTH "L" AT DRIVEWAYS WITHOUT ATTACHED SIDEWALK SHALL BE IN ACCORDANCE WITH THE DRIVEWAY RAMP RUNNING SLOPE TABLE.

REVISION: 2024 M.A.S.S. UPDATE

 <p>MUNICIPALITY OF ANCHORAGE</p>	<p>SCALE: N.T.S.</p> <p>APPROVED:</p> <p>REVISED: 10/23</p>	<p><b>DRIVEWAY CURB-CUT WITH ATTACHED SIDEWALK</b></p>	<p>SECTION # 30.03</p> <p>DETAIL # 30-6</p>
--	---	--	---

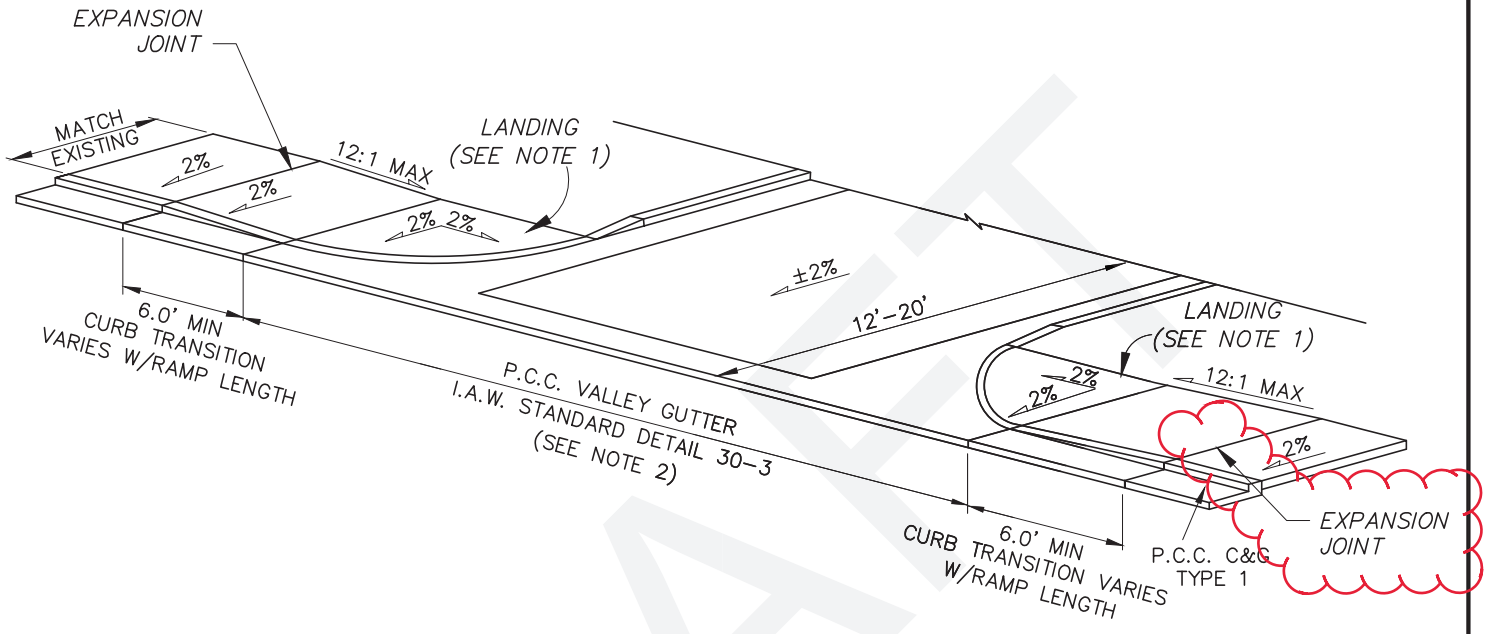

NOTES:

1. SIZE LANDING TO MEET ADA REQUIREMENTS.
2. ASPHALT CONCRETE SWALES TO BE CONSTRUCTED ON ALL ROADWAYS UNLESS P.C.C. VALLEY GUTTER IS SPECIFIED ON DRAWINGS. CONTRACTOR TO DEPRESS LIPS OF GUTTER TO ENSURE ADEQUATE DRAINAGE.

REVISION: 2024 M.A.S.S. UPDATE

 <p>MUNICIPALITY OF ANCHORAGE</p>	<p>SCALE: N.T.S.</p> <p>APPROVED:</p> <p>REVISED: 10/23</p>	<p><b>DRIVEWAY CURB RETURN WITH ATTACHED SIDEWALK</b></p>	<p>SECTION # 30.03</p> <p>DETAIL # 30-7</p>
--	---	---	---

## GENERAL CURB RAMP NOTES:

1. SEE DRAWINGS FOR REFERENCE POINT STATION AND OFFSET.
2. CONSTRUCT PERPENDICULAR AND PARALLEL RAMPS AND LANDINGS WITH A BROOM FINISH PARALLEL TO THE CURB. CONSTRUCT UNIDIRECTIONAL RAMPS AND LANDINGS WITH A BROOM FINISH PERPENDICULAR TO THE LONG DIRECTION OF THE RAMP.
3. THE CONTRACTOR SHALL CONSTRUCT THE RAMP PORTION OF THE CURB RAMP WITH A 2.0% MAXIMUM CROSS SLOPE WITH NO MANHOLES, UTILITY JUNCTION BOXES, OR OTHER OBSTRUCTIONS. THE MAXIMUM RUNNING SLOPE SHALL BE 8.33%, BUT SHALL NOT REQUIRE THE RAMP LENGTH TO EXCEED 15 FEET MEASURED ALONG THE BACK OF THE RAMP. NO JOINTS SHALL BE PLACED WITHIN THE RAMP UNLESS NOTED OTHERWISE.
4. THE CONTRACTOR SHALL CONSTRUCT LANDINGS WITH A 2.0% MAXIMUM RUNNING SLOPE AND CROSS SLOPE WITH NO MANHOLES, UTILITY JUNCTION BOXES, OR OTHER OBSTRUCTIONS.
5. SLOPES INDICATED AS MAXIMUM ARE NOT SUBJECT TO CONSTRUCTION TOLERANCES. WHEN FINISHED SLOPES EXCEED MAXIMUMS INDICATED ON THE DETAILS, RAMP INSTALLATIONS WILL BE REJECTED AND RE-CONSTRUCTION WILL BE REQUIRED AT THE CONTRACTOR'S SOLE EXPENSE. DESIGNERS AND CONTRACTORS ARE ENCOURAGED TO PLAN FOR SLOPES LESS THAN THE MAXIMUM INDICATED ON THE DETAILS.
6. THE CONTRACTOR SHALL INSTALL DETECTABLE WARNING PANELS (D.W.) IN ACCORDANCE WITH MANUFACTURER'S RECOMMENDATIONS AND THE DRAWINGS. SET DETECTABLE WARNING PANELS SO THAT THE FIELD AREA AT THE BASE OF THE DOMES IS FLUSH WITH THE SURROUNDING CONCRETE. NO LIP IS ALLOWED AT THE EDGE OF THE DETECTABLE WARNING PANELS. D.W. SHALL BE FEDERAL YELLOW, OR APPROVED EQUAL. WHERE RADIAL D.W. ARE REQUIRED TO MEET OFFSET DIMENSIONS AND MANUFACTURED RADIAL D.W. ARE NOT AVAILABLE, CONTRACTOR SHALL CUT D.W. I.A.W. MANUFACTURER'S RECOMMENDATIONS TO PROVIDE RADIAL D.W. AS SHOWN ON THE DRAWINGS. WHERE POSSIBLE, FINISHED EDGES WILL BE PLACED ON THE OUTER BOUNDARIES OF THE D.W.
7. THE DETECTABLE WARNING PANEL SURFACE SHALL SPAN THE FULL WIDTH OF THE CURB RAMP, SHARED USE PATH, OR OTHER ROADWAY ENTRANCE, AS APPLICABLE, A GAP OF 2 INCHES MAXIMUM FROM THE EDGE OF THE DETECTABLE WARNING SURFACE TO THE EDGE OF THE CURB RAMP OR SHARED USE PATH IS PERMITTED WHEN DETECTABLE WARNING PRODUCT REQUIRES A CONCRETE BORDER FOR PROPER INSTALLATION.
8. TRIM OUTSIDE EDGES AND JOINTS OF RAMP AND FLARES WITH ONE-QUARTER INCH (1/4") RADIUS EDGING TOOL.
9. TOP OF A.C. PAVEMENT SHALL BE AT THE SAME LEVEL AS LIP OF CURB FOR P.C.C. CURB AND GUTTER TYPE 1A AND/OR 2A.
10. CONTRACTOR SHALL CONSTRUCT P.C.C. CURB BEHIND LANDING AND RAMPS WHERE SHOWN OR AS DIRECTED BY THE ENGINEER. P.C.C. CURB IS INCIDENTAL TO CURB RAMP AND NO ADDITIONAL PAYMENT WILL BE MADE.
11. FOR UNIDIRECTIONAL RAMPS, IF LANDING LENGTH IS LESS THAN 5', CONTRACTOR SHALL INSTALL D.W. AT THE BOTTOM OF THE RAMP. IF THE LANDING LENGTH IS EQUAL TO OR GREATER THAN 5', CONTRACTOR SHALL INSTALL RADIAL DETECTABLE WARNING ALONG TOP BACK OF CURB FOR THE WIDTH OF THE LANDING. ONLY ONE OF THE DETECTABLE WARNING CONFIGURATIONS SHOWN WILL BE CONSTRUCTED.

MUNICIPALITY



OF ANCHORAGE

SCALE:  
N.T.S.

APPROVED:

REVISED:  
10/23

## CURB RAMP NOTES

SECTION #  
30.04

DETAIL #  
30-8

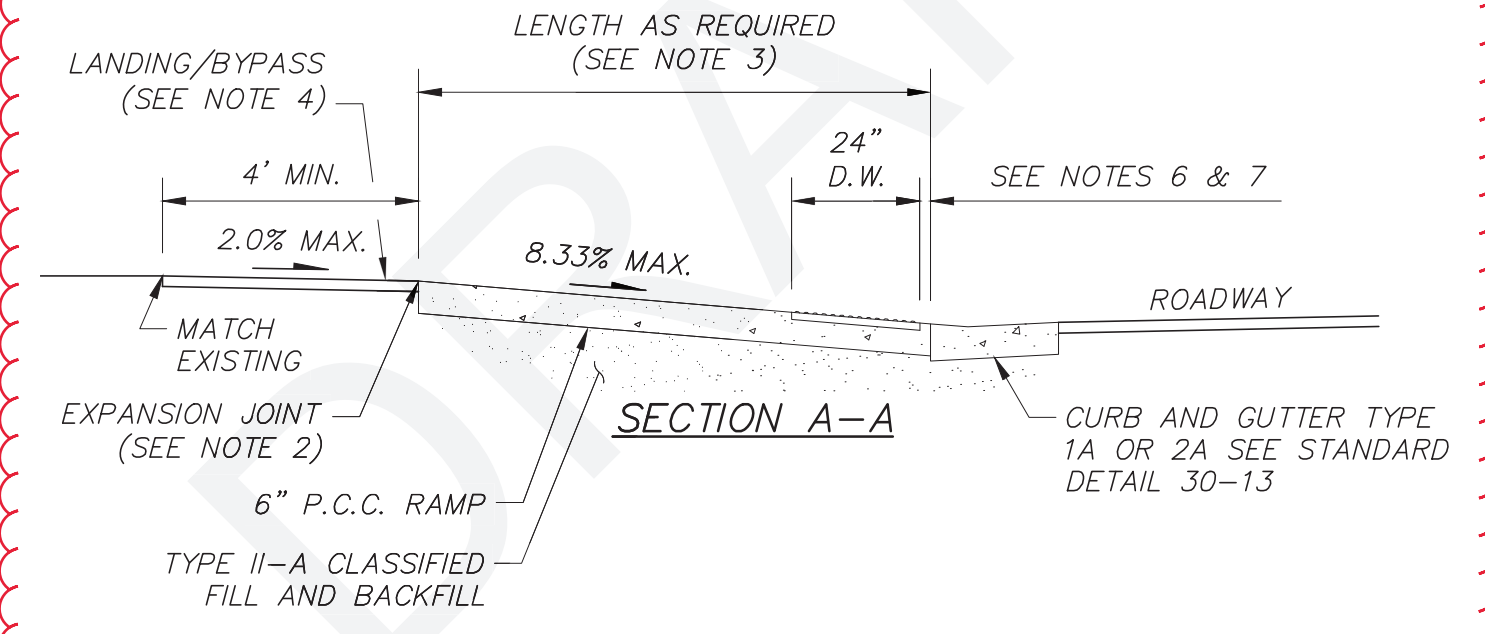
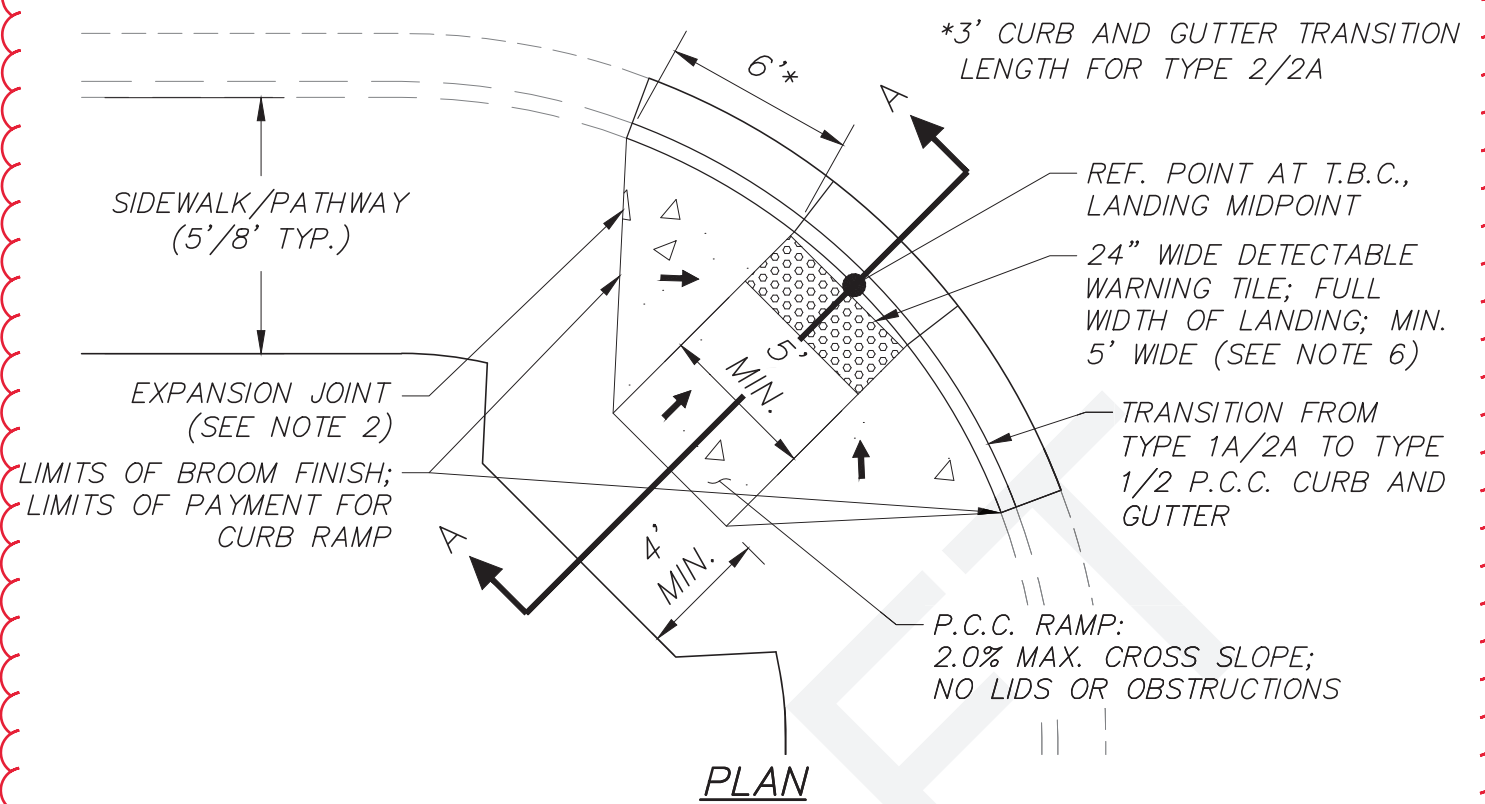

**NOTES:**

1. CURB RAMP NOTES ARE PROVIDED IN STANDARD DETAIL 30-8.
2. EXPANSION JOINTS LOCATED BETWEEN THE CURB RAMP AND THE ASPHALT PATHWAY ARE NOT REQUIRED.

REVISION: 2024 M.A.S.S. UPDATE

 <p>MUNICIPALITY OF ANCHORAGE</p>	<p>SCALE: N.T.S.</p> <p>APPROVED:</p> <p>REVISED: 10/23</p>	<p><b>PERPENDICULAR CURB RAMP</b></p>	<p>SECTION # 30.04</p> <p>DETAIL # 30-9</p>
--	---	---------------------------------------	---

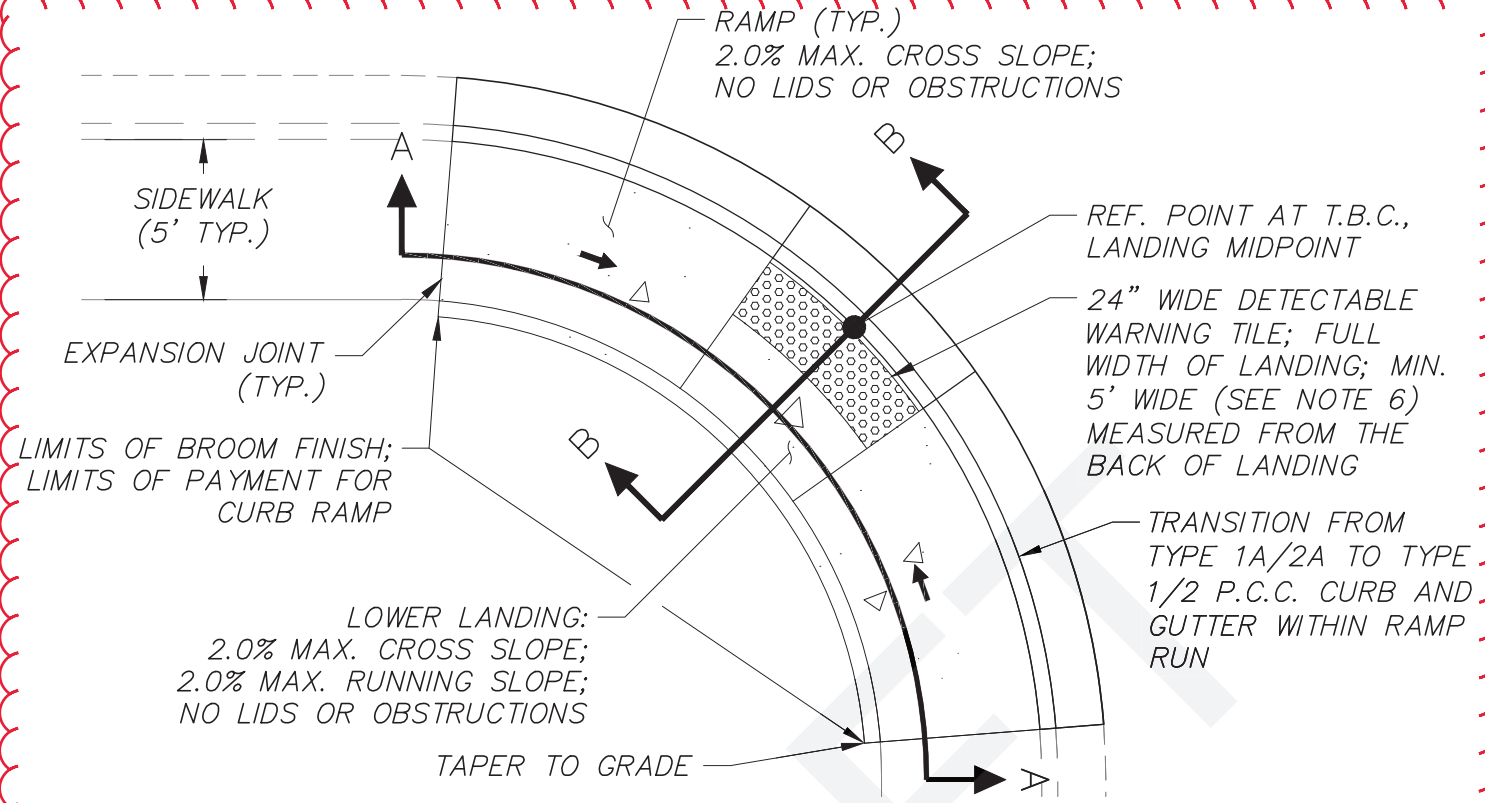

**PLAN**

**NOTE:**

1. CURB RAMP NOTES ARE PROVIDED IN STANDARD DETAIL 30-8.

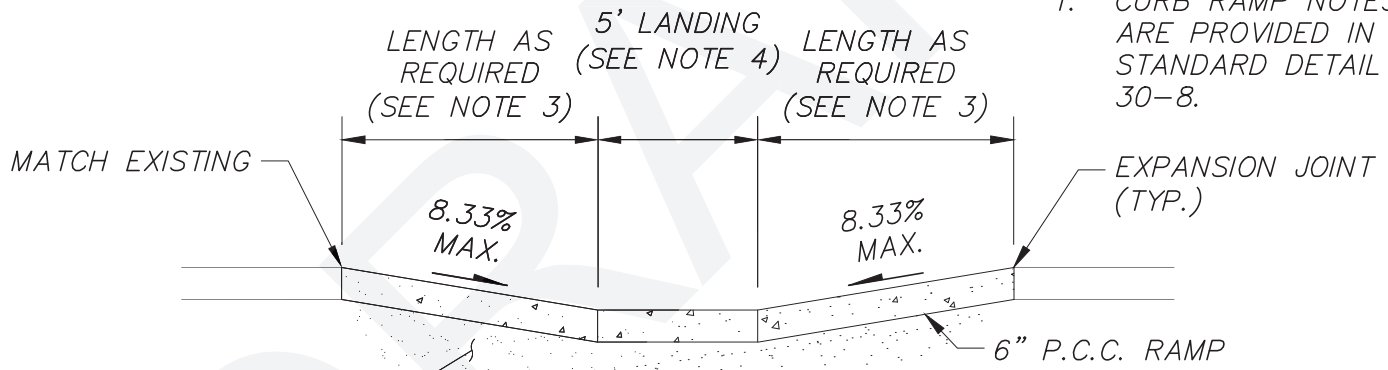

**SECTION A-A**

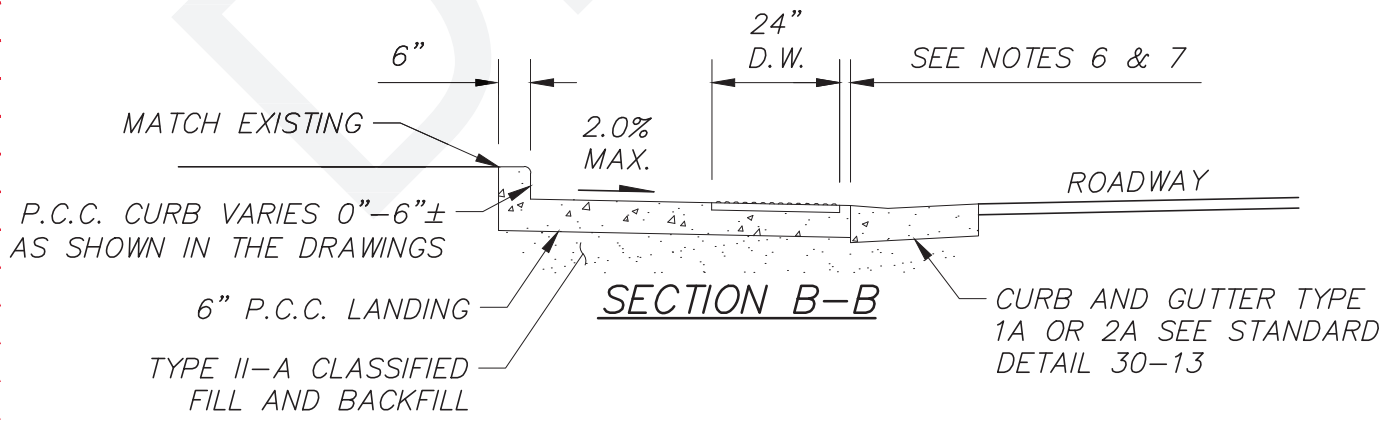

**SECTION B-B**

REVISION: 2024 M.A.S.S. UPDATE

MUNICIPALITY

OF ANCHORAGE

SCALE:  
N.T.S.

APPROVED:

REVISED:  
10/23

**PARALLEL CURB RAMP**

SECTION #  
30.04

DETAIL #  
30-10

RAMP (TYP.)  
2.0% MAX. CROSS SLOPE;  
NO LIDS OR OBSTRUCTIONS

RAMP FLARE (TYP.)

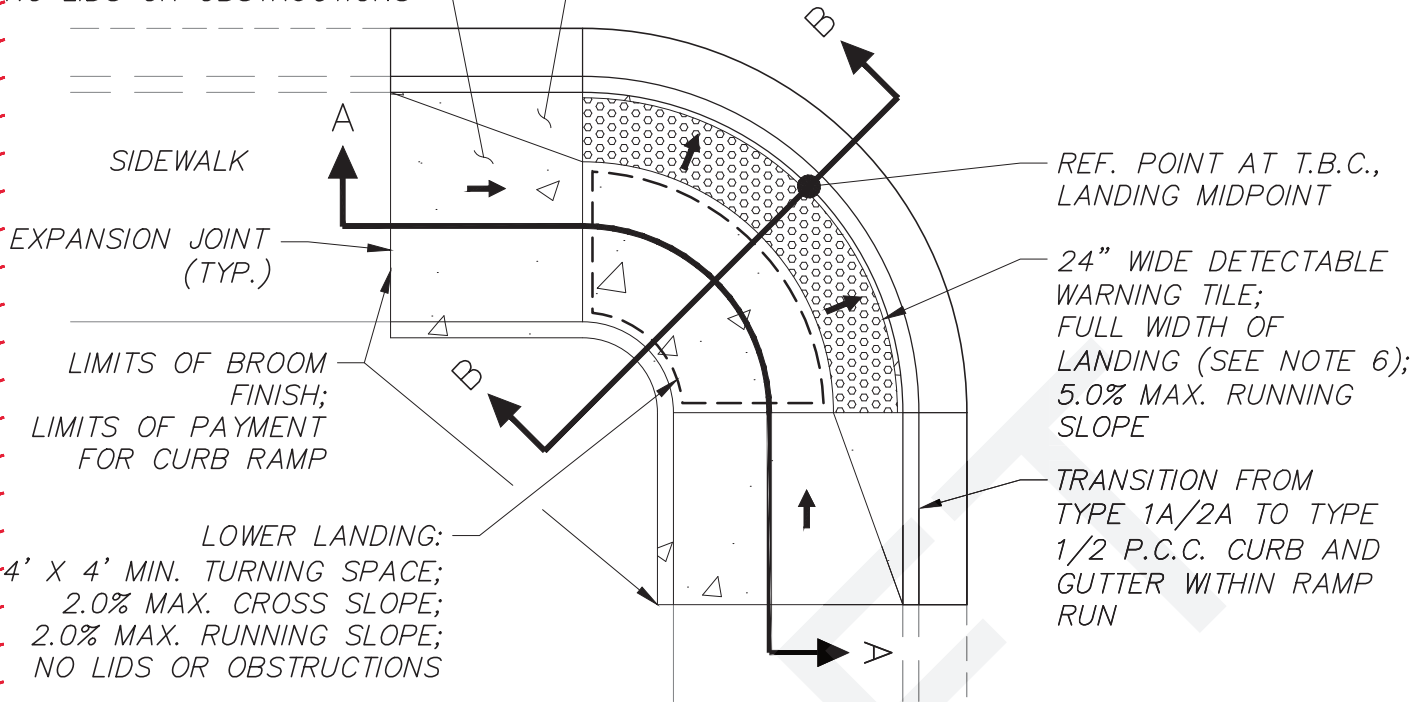

**PLAN**

**NOTE:**

1. CURB RAMP NOTES ARE PROVIDED IN STANDARD DETAIL 30-8.

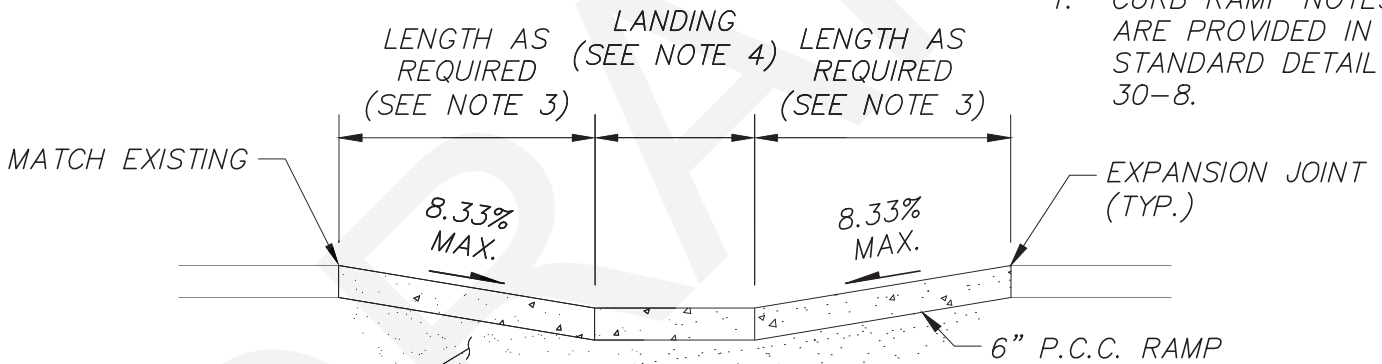

**SECTION A-A**

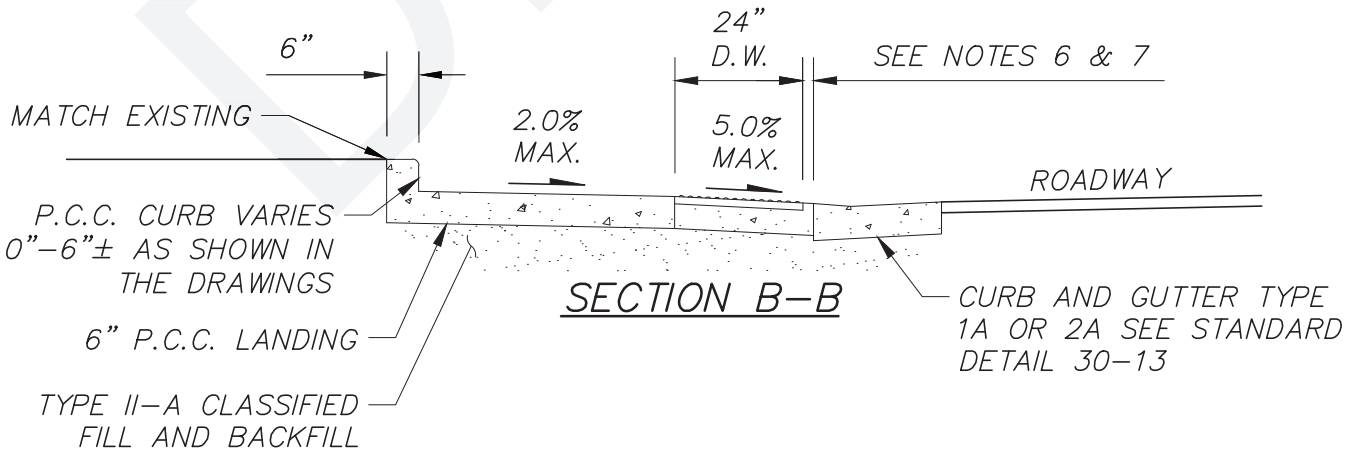

**SECTION B-B**

REVISION: 2024 M.A.S.S. UPDATE

MUNICIPALITY



OF ANCHORAGE

SCALE:  
N.T.S.

APPROVED:

REVISED:  
10/23

**BLENDED TRANSITION  
CURB RAMP**

SECTION #  
30.04

DETAIL #  
30-11

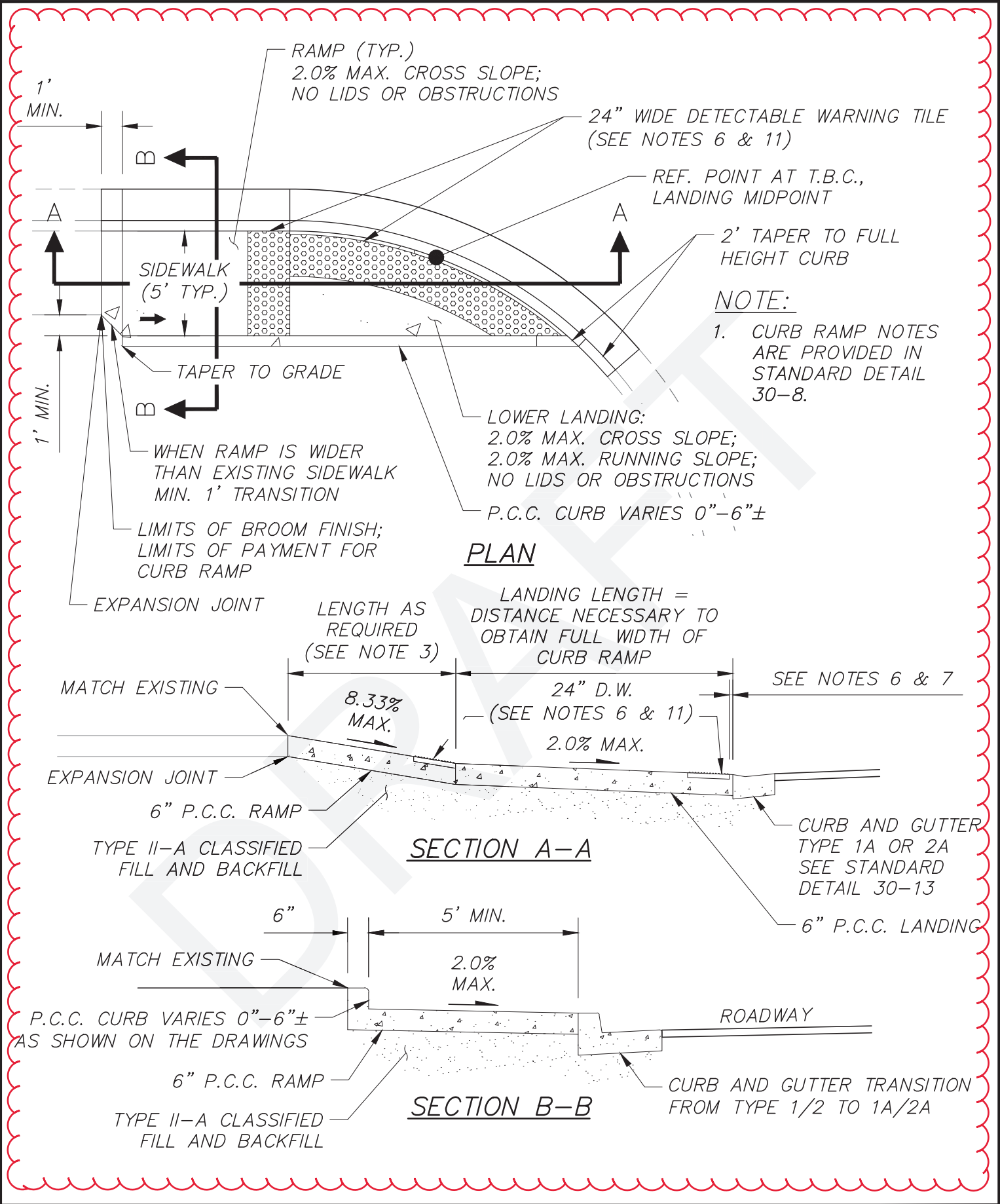

**NOTE:**  
 1. CURB RAMP NOTES ARE PROVIDED IN STANDARD DETAIL 30-8.

**PLAN**

**SECTION A-A**

**SECTION B-B**

REVISION: 2024 M.A.S.S. UPDATE

MUNICIPALITY  
  
 OF ANCHORAGE

SCALE:  
 N.T.S.  
 APPROVED:  
 REVISED:  
 10/23

**UNIDIRECTIONAL CURB RAMP**

SECTION #  
 30.04  
 DETAIL #  
 30-12



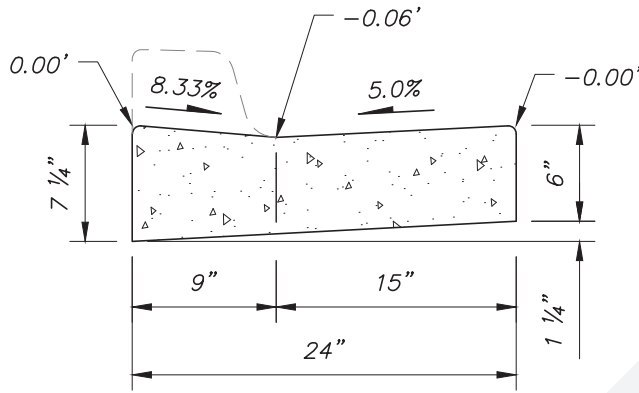

P.C.C. CURB AND GUTTER  
TYPE 1A  
 (FOR USE IN CURB RAMPS)

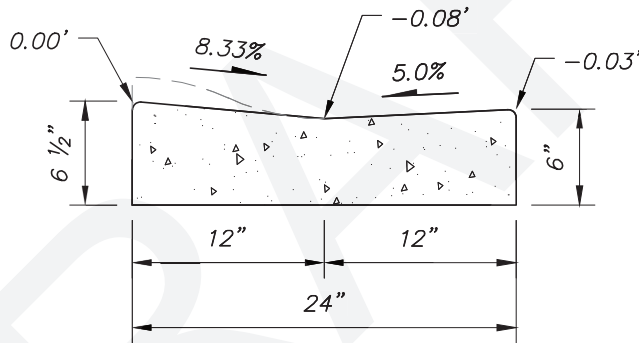

P.C.C. CURB AND GUTTER  
TYPE 2A  
 (FOR USE IN CURB RAMPS)

NOTE:

1. TRANSITION CURBS TO MAINTAIN CONSTANT FLOWLINE ACROSS CURB RAMP AND AROUND CURB RETURN PER THE DRAWINGS.

REVISION: 2024 M.A.S.S. UPDATE



SCALE:  
N.T.S.  
APPROVED:  
REVISED:  
10/23

**ACCESSIBLE CURB AND  
GUTTER CROSS SECTIONS**

SECTION #  
30.04

DETAIL #  
30-13

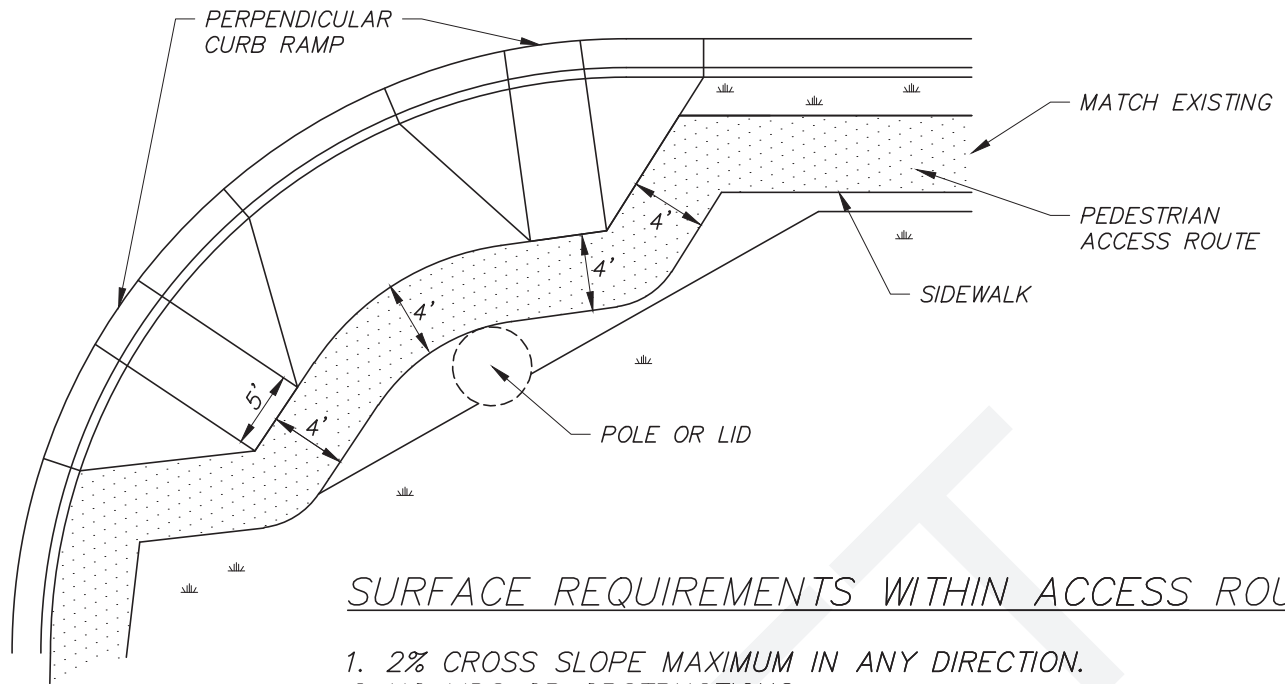

SURFACE REQUIREMENTS WITHIN ACCESS ROUTE:

1. 2% CROSS SLOPE MAXIMUM IN ANY DIRECTION.
2. NO LIDS OR OBSTRUCTIONS.
3. CONNECTED ACCESS TO PED SIGNAL BUTTON I.A.W. STANDARD DETAIL 30-12.

MINIMUM PEDESTRIAN ACCESS ROUTE  
AROUND PERPENDICULAR CURB RAMPS

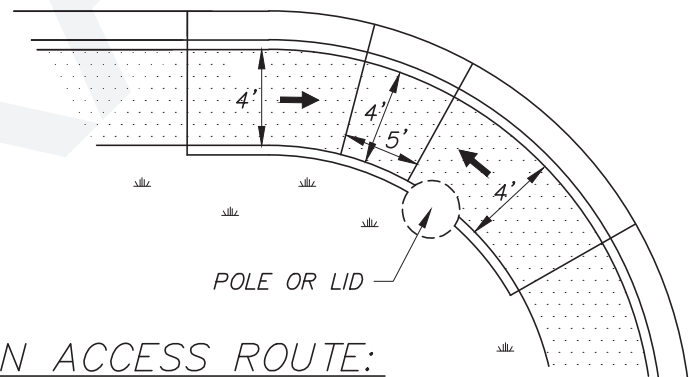

SURFACE REQUIREMENTS WITHIN ACCESS ROUTE:

1. 2% CROSS SLOPE MAXIMUM IN ANY DIRECTION.
2. NO LIDS OR OBSTRUCTIONS.
3. CONNECTED ACCESS TO PED SIGNAL BUTTON I.A.W. STANDARD DETAIL 30-12.

MINIMUM PEDESTRIAN ACCESS ROUTE  
THROUGH PARALLEL RAMPS

REVISION: 2024 M.A.S.S. UPDATE

 <p>MUNICIPALITY OF ANCHORAGE</p>	<p>SCALE: N.T.S.</p> <p>APPROVED:</p> <p>REVISED: 10/23</p>	<h1>CURB RAMP CLEARANCES</h1>	<p>SECTION # 30.04</p> <p>DETAIL # 30-14</p>
--	---	-------------------------------	--

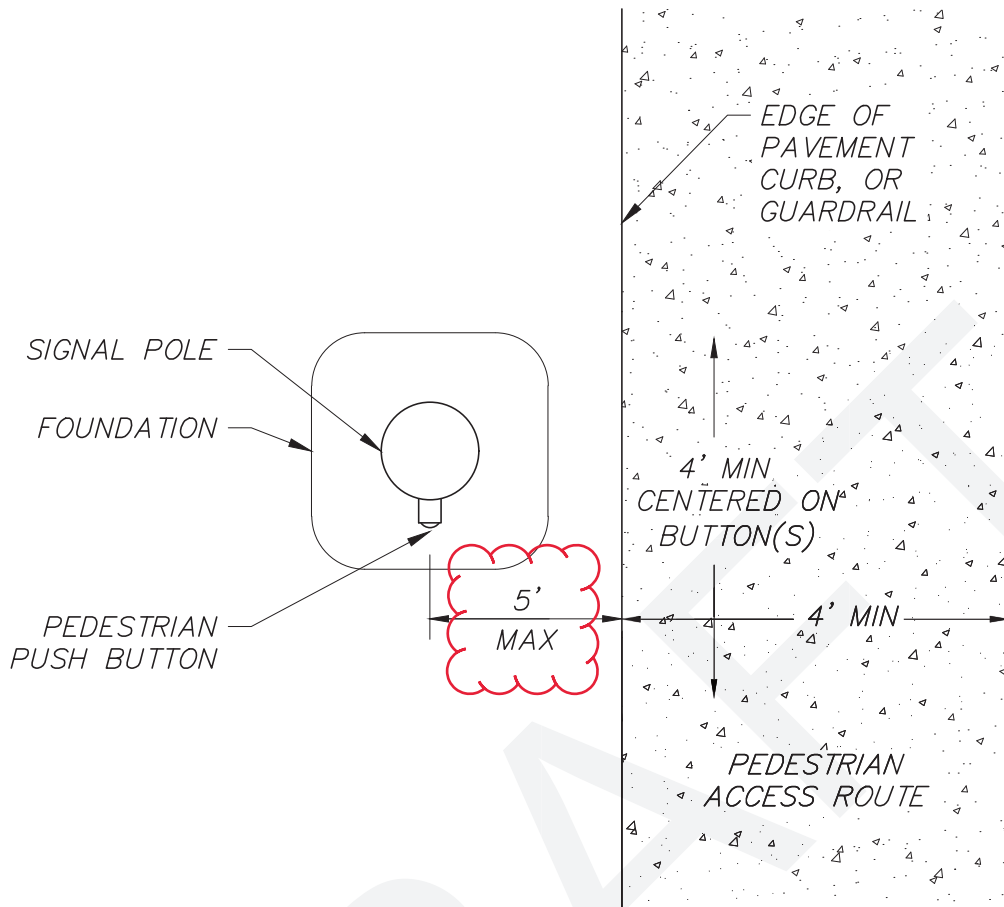

## ACCESSIBLE PEDESTRIAN PUSH BUTTON APPROACH

### NOTES:

1. PEDESTRIAN PUSH BUTTONS SHALL HAVE AN ACCESSIBLE APPROACH AS SHOWN.
2. APPROACH AREA SHALL JOIN OR OVERLAP THE MAIN SIDEWALK/PATHWAY, AND SHALL BE SURFACED WITH THE SAME MATERIAL.
3. APPROACH SHALL NOT EXCEED 2% SLOPE IN ANY DIRECTION.
4. APPROACH SHALL BE FREE FROM LIDS, OBSTRUCTIONS, AND LIPS.



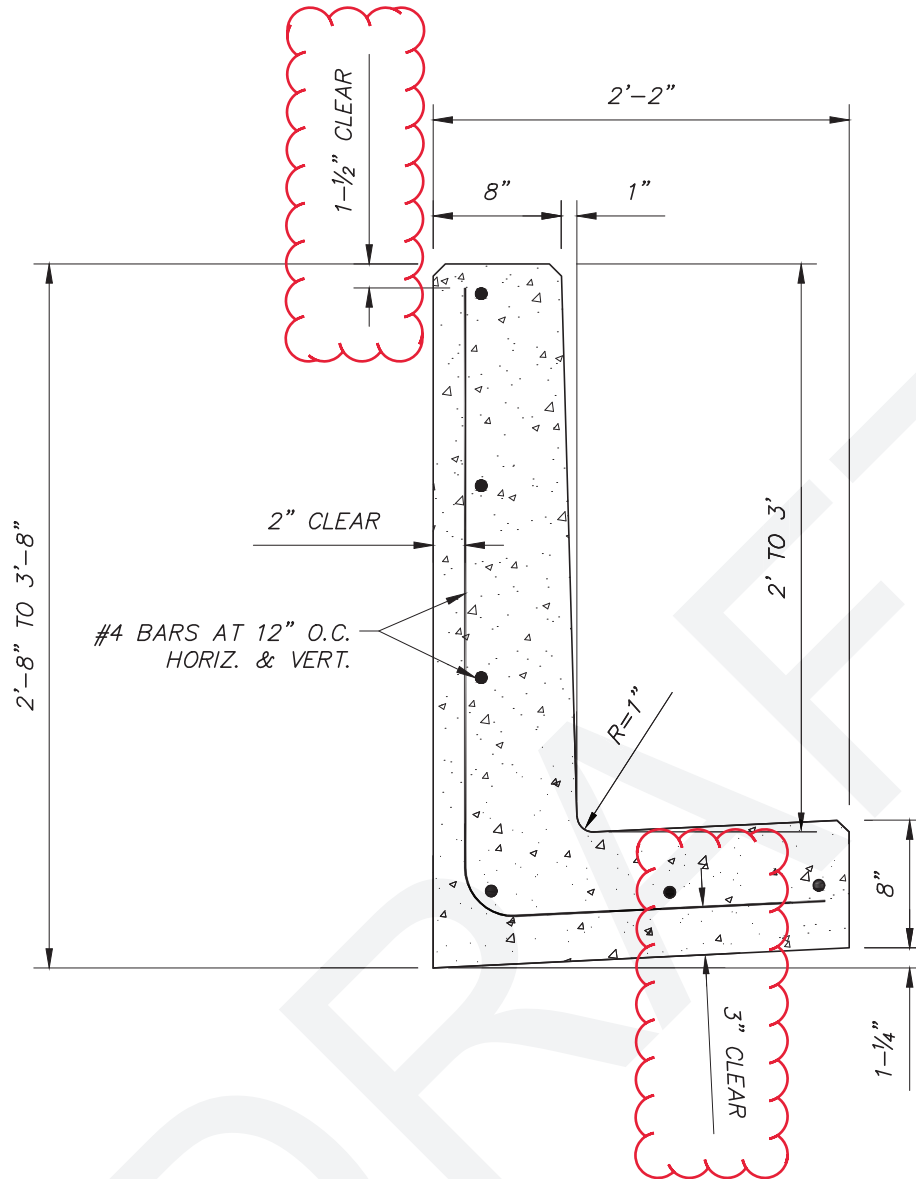

**NOTES:**

1. PROVIDE  $\frac{3}{4}$ " X  $\frac{3}{4}$ " CHAMFERED CORNERS AT ALL OUTSIDE EDGES.
2. NO VEHICLE TRAFFIC WITHIN 3' OF TOP OF WALL.

REVISION: 2024 M.A.S.S. UPDATE

 <p>MUNICIPALITY OF ANCHORAGE</p>	<p>SCALE: N.T.S.</p> <p>APPROVED:</p> <p>REVISED: 10/23</p>	<p><b>CURB TYPE RETAINING WALL</b></p> <p><b>2' TO 3'</b></p>	<p>SECTION # 30.05</p> <p>DETAIL # 30-16</p>
--	---	---	--

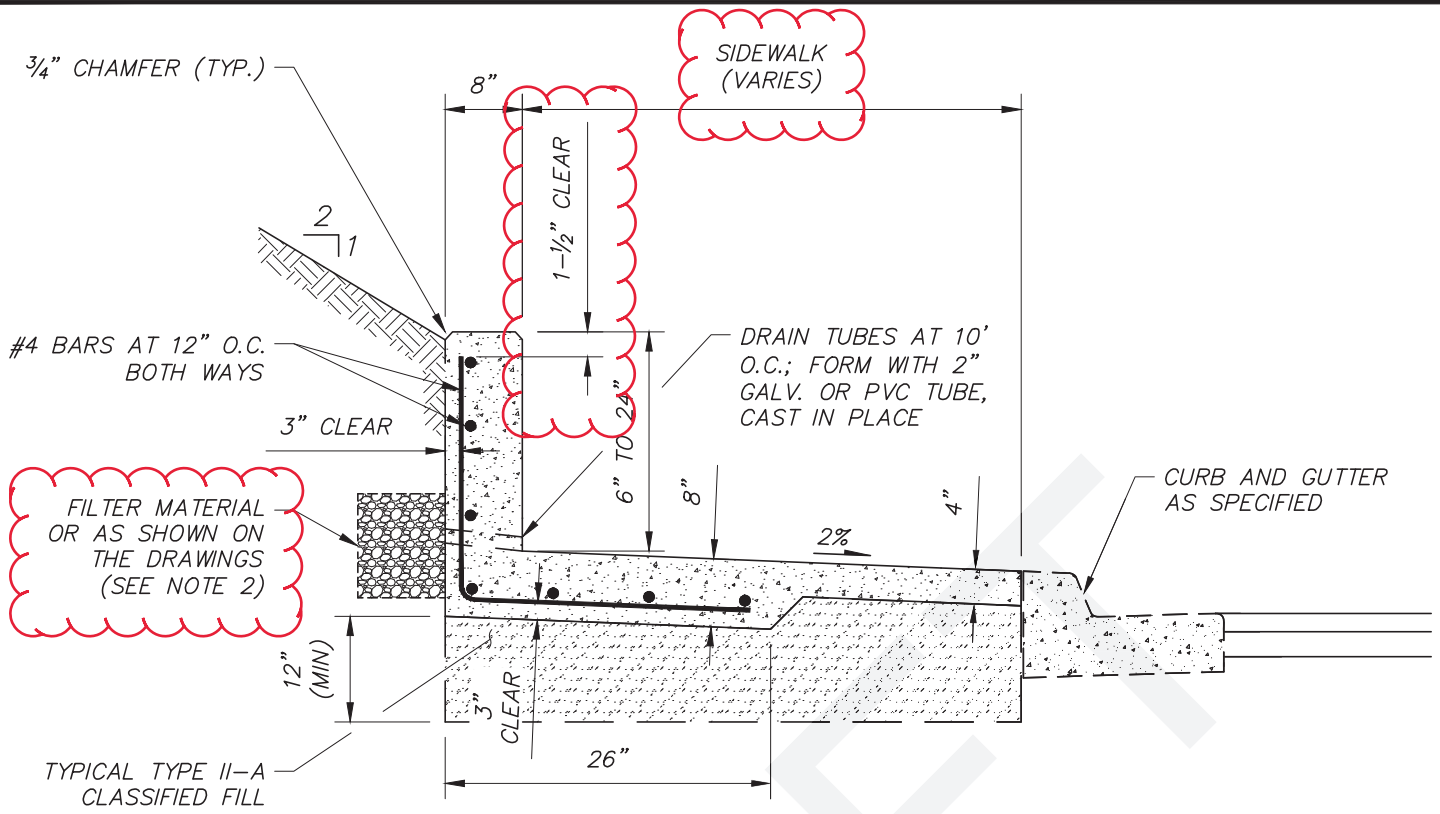

**SIDEWALK RETAINING WALL**

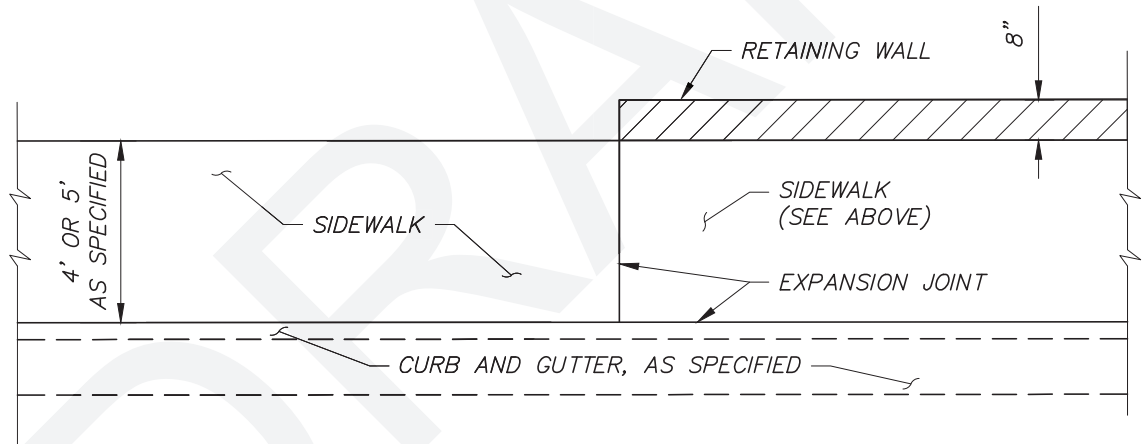

**TRANSITION DETAIL  
(PLAN VIEW)**

**NOTES:**

1. STANDARD CURB AND GUTTER SECTION NOT INCLUDED IN UNIT BID PRICE FOR RETAINING WALL.
2. PLACE ONE CUBIC FOOT OF FILTER MATERIAL AROUND WEEP HOLE AS SHOWN.
3. PROVIDE 3/4" X 3/4" CHAMFERED CORNERS AT ALL OUTSIDE EDGES.
4. NO VEHICLE TRAFFIC WITHIN 2' OF TOP OF WALL.

REVISION: 2024 M.A.S.S. UPDATE

MUNICIPALITY  
  
 OF ANCHORAGE

SCALE:  
N.T.S.  
 APPROVED:  
 REVISED:  
10/23

**SIDEWALK RETAINING WALL  
6" TO 24"**

SECTION #  
30.05  
 DETAIL #  
30-17

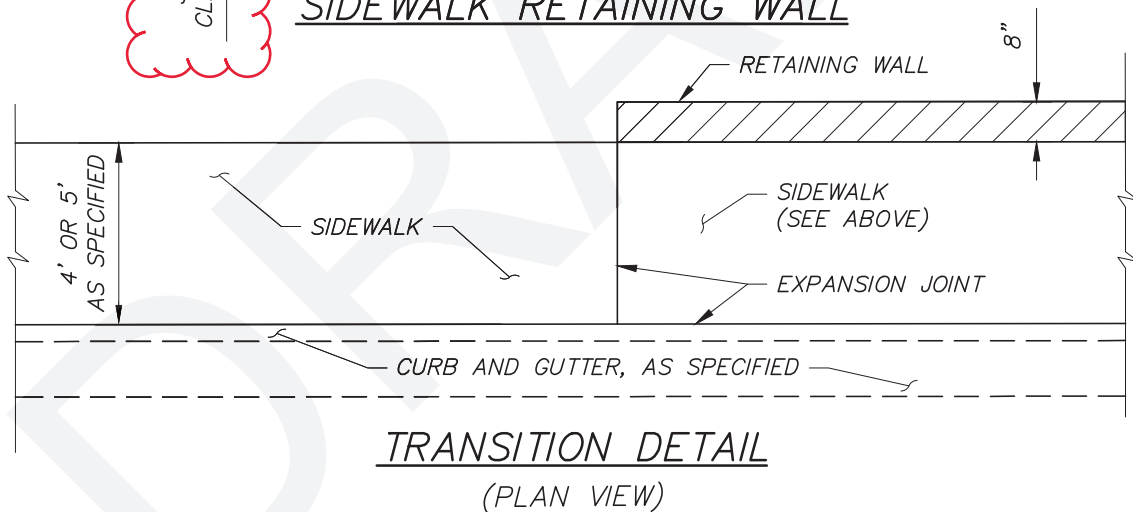
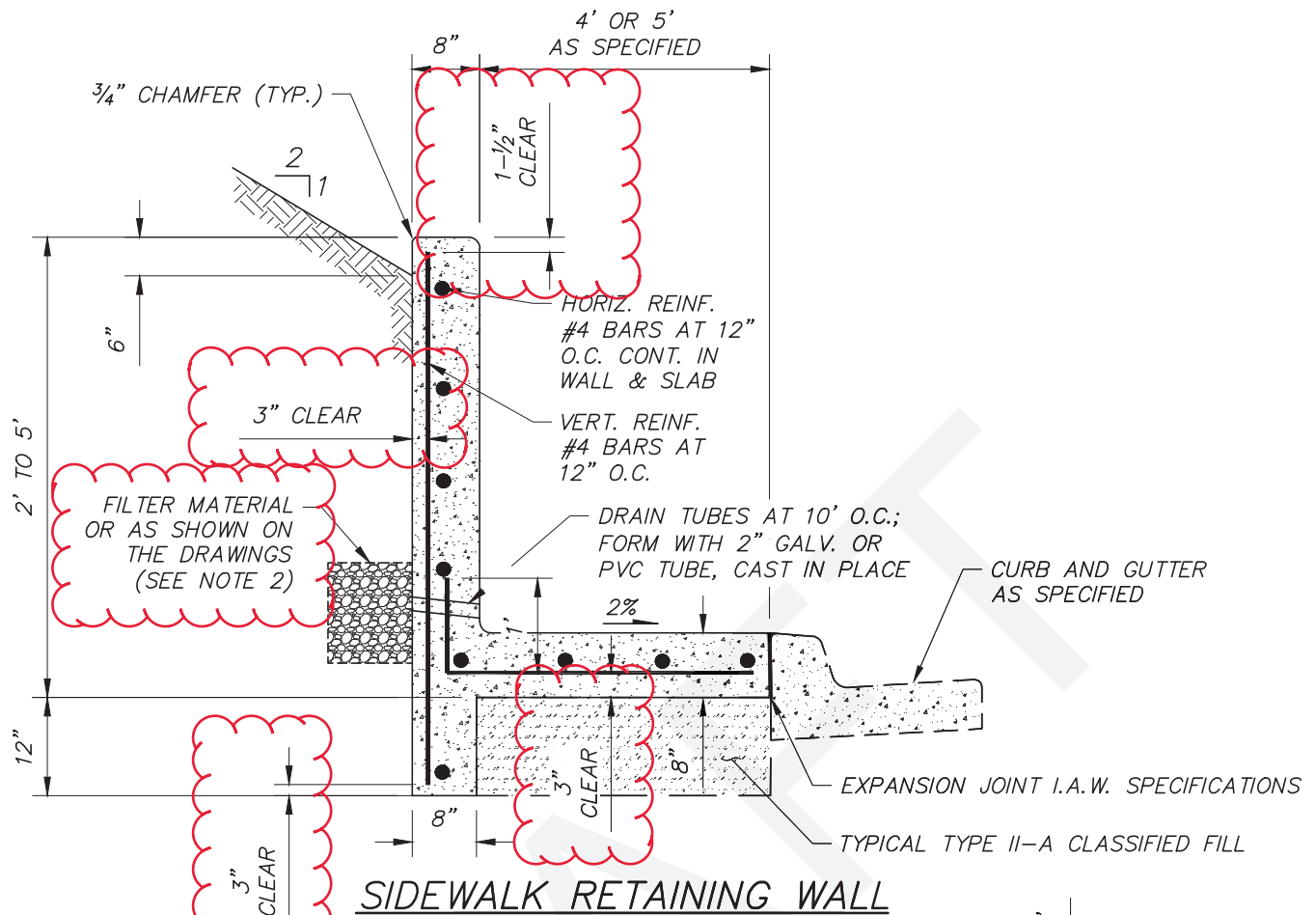

**NOTES:**

1. STANDARD CURB AND GUTTER SECTION NOT INCLUDED IN UNIT BID PRICE FOR RETAINING WALL.
2. PLACE ONE CUBIC FOOT OF FILTER MATERIAL AROUND WEEP HOLE AS SHOWN.
3. PROVIDE 3/4" X 3/4" CHAMFERED CORNERS AT ALL OUTSIDE EDGES.
4. NO VEHICLE TRAFFIC WITHIN 5' OF TOP OF WALL.

REVISION: 2024 M.A.S.S. UPDATE

<p>MUNICIPALITY</p>  <p>OF ANCHORAGE</p>	<p>SCALE: N.T.S.</p> <p>APPROVED:</p> <p>REVISED: 10/23</p>	<p><b>SIDEWALK RETAINING WALL</b></p> <p><b>2' TO 5'</b></p>	<p>SECTION # 30.05</p> <p>DETAIL # 30-18</p>
---	---	--	--

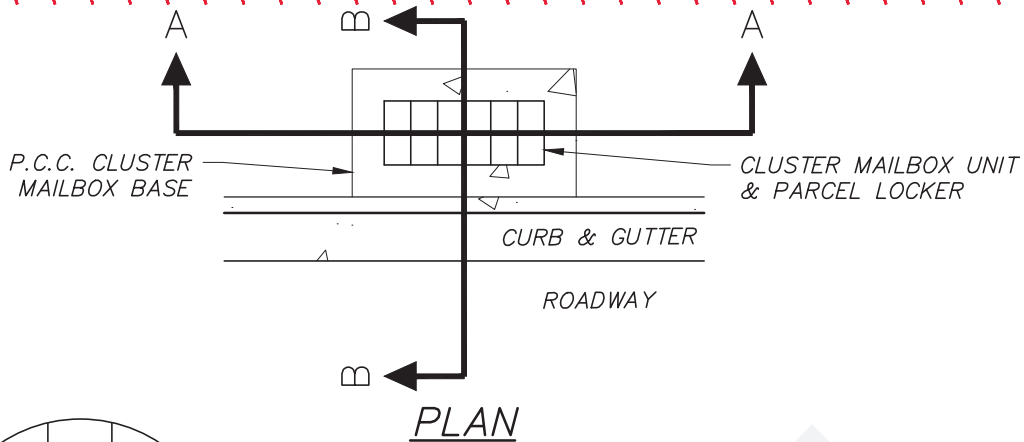

**PLAN**

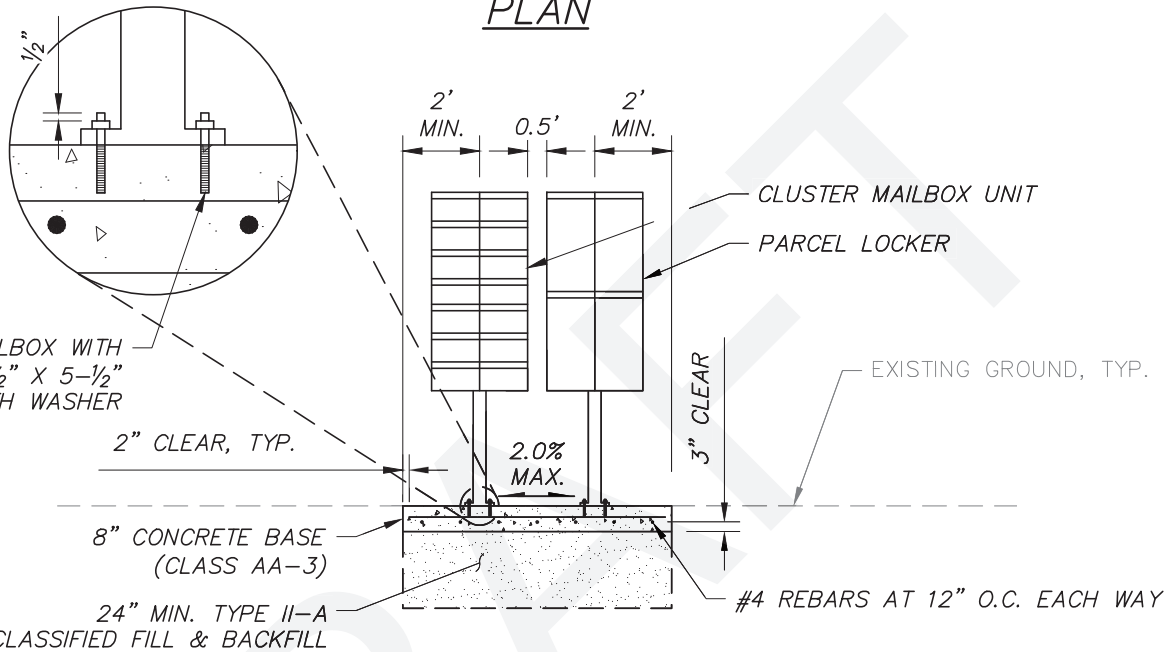

**SECTION A-A**

**NOTES:**

1. LOCATE CLUSTER MAILBOX AND PARCEL LOCKER IN ACCORDANCE WITH DETAIL 70-40.
2. FOR GRADING PURPOSES, CONSTRUCT BACKING CURB AT THE OUTSIDE EDGE OF THE P.C.C. CLUSTER MAILBOX BASE AS NECESSARY TO MATCH EXISTING GROUND. PROVIDE A 2' TAPER FROM THE BACK OF CURB AND GUTTER TO FULL HEIGHT BACKING CURB.
3. PROVIDE A LIGHT BROOM FINISH.

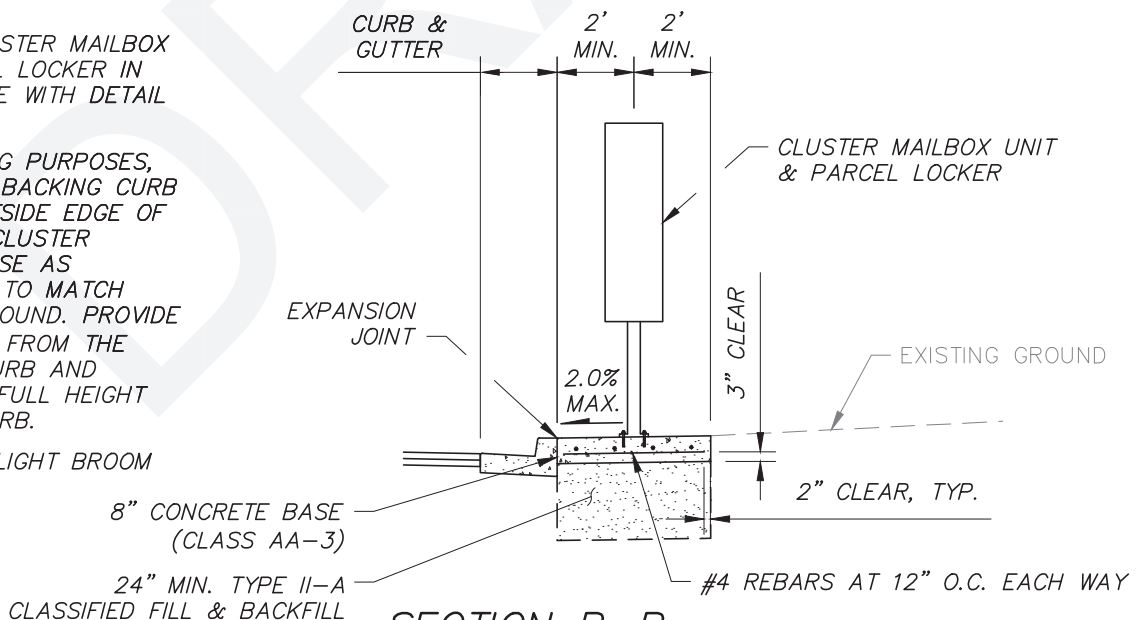

**SECTION B-B**

REVISION: 2024 M.A.S.S. UPDATE

MUNICIPALITY



OF ANCHORAGE

SCALE:  
N.T.S.

APPROVED:

REVISED:  
10/23

**P.C.C. CLUSTER MAILBOX  
BASE**

SECTION #  
30.08

DETAIL #  
30-19