

**MUNICIPALITY OF ANCHORAGE
STANDARD SPECIFICATIONS**

**DIVISION 85
TRAFFIC CONTROL DEVICES**

**STANDARD CONSTRUCTION SPECIFICATIONS
TRAFFIC CONTROL DEVICES
DIVISION 85
INDEX**

SECTION 85.01	GENERAL	1
Article 1.1	Scope of Work.....	1
Article 1.2	Applicable Standards	1
SECTION 85.02	RESET PARKING METERS	2
Article 2.1	General	2
Article 2.2	Construction	2
Article 2.3	Measurement	2
Article 2.4	Basis of Payment	2
SECTION 85.03	TRAFFIC MARKINGS	3
Article 3.1	General	3
Article 3.2	Materials	3
Article 3.3	Construction	4
Article 3.4	Measurement	7
Article 3.5	Basis of Payment	8
SECTION 85.04	STANDARD SIGNS	9
Article 4.1	General	9
Article 4.2	Materials	9
Article 4.3	Construction	12
Article 4.4	Measurement	14
Article 4.5	Basis of Payment	14
SECTION 85.05	TRAFFIC MAINTENANCE	15
Article 5.1	General	15
Article 5.2	Traffic Control Plan	15
Article 5.3	Pedestrian Traffic.....	16
Article 5.4	Work Site Traffic Supervisor.....	17
Article 5.5	Materials	18
Article 5.6	Public Notice	19
Article 5.7	Traffic Control Devices.....	20
Article 5.8	Authority of the Engineer.....	21
Article 5.9	Execution	21
Article 5.10	Measurement	22
Article 5.11	Basis of Payment	22
SECTION 85.06	REMOVE GUARDRAIL.....	23
Article 6.1	General	23
Article 6.2	Construction	23
Article 6.3	Measurement	23
Article 6.4	Basis of Payment	23

SECTION 85.07	GUARDRAIL	24
Article 7.1	General	24
Article 7.2	Material	24
Article 7.3	Construction	24
Article 7.4	Measurement	24
Article 7.5	Basis of Payment	24
SECTION 85.08	TEMPORARY GROUP MAILBOXES.....	25
Article 8.1	General	25
Article 8.2	Materials	25
Article 8.3	Construction	25
Article 8.4	Measurement	25
Article 8.5	Basis of Payment	25
SECTION 85.09	RELOCATE MAILBOX.....	26
Article 9.1	General	26
Article 9.2	Materials	26
Article 9.3	Construction	26
Article 9.4	Measurement	26
Article 9.5	Basis of Payment	27
SECTION 85.10	FLEXIBLE DELINEATORS	28
Article 10.1	General	28
Article 10.2	Submittals	28
Article 10.3	Materials	28
Article 10.4	Construction	28
Article 10.5	Measurement	28
Article 10.6	Basis of Payment	28
SECTION 85.11	PERMANENT VERTICAL TRAFFIC CALMING DEVICES.....	29
Article 11.1	General	29
Article 11.2	Cross Section Template.....	29
Article 11.3	Material	29
Article 11.4	Construction	29
Article 11.5	Measurement	29
Article 11.6	Basis of Payment	30
SECTION 85.12	MULTI-MODAL COUNTERS	31
Article 12.1	General	31
Article 12.2	Material	31
Article 12.3	Construction	31
Article 12.4	Measurement	34
Article 12.5	Payment.....	34

**STANDARD CONSTRUCTION SPECIFICATIONS
TRAFFIC CONTROL DEVICES
DIVISION 85**

SECTION 85.01 GENERAL

Article 1.1 Scope of Work

The Work covered by these Specifications consists of providing all plant, labor, equipment, supplies, materials, transportation, handling and storage, and performing all operations in connection with traffic control devices as provided in this Division.

Article 1.2 Applicable Standards

The latest revision of the following standards of the American Society for Testing and Materials (ASTM) and the American Association of State Highway and Transportation Officials (AASHTO) are hereby made a part of these Specifications.

ASTM A1	Specification for Carbon Steel Tee Rails
ASTM A36	Specification for Carbon Structural Steel
ASTM A153	Specification for Zinc-Coated (Hot Dip) on Iron and Steel Hardware
ASTM A307	Specification for Low-Carbon Steel Externally and Internally Threaded Standard Fasteners
ASTM A653	Specification for Steel Sheet, Zinc-Coated (Galvanized) or Zinc-Iron Alloy-Coated (Galvannealed) by the Hot-Dip Process
ASTM B209	Specification for Aluminum and Aluminum-Alloy Sheet and Plate
ASTM B449	Specification for Chromates on Aluminum
ASTM B921	Specification for Non-hexavalent Chromium Conversion Coatings on Aluminum and Aluminum Alloys
ASTM D4956	Specification for Retroreflective Sheeting for Traffic Control
ASTM E303	Test Method for Measuring Surface Frictional Properties Using the British Pendulum Tester
AASHTO M 133	Specification for Preservatives and Pressure Treatment Processes for Timber
AASHTO M 180	Specification for Corrugated Sheet Steel Beams for Highway Guardrail

SECTION 85.02 RESET PARKING METERS

Article 2.1 General

The Work under this Section consists of performing all operations pertaining to furnishing all equipment, materials, and personnel to remove and reset existing parking meter post assemblies.

Article 2.2 Construction

All posts shall be placed in excavated holes. Depth of embedment shall be as shown on Drawings, unless otherwise directed.

Surplus excavated material shall be disposed of by the Contractor and shall be incidental to this bid item.

All materials and finished parking meter installations are subject to inspection and acceptance in place by the Anchorage Parking Authority. Contact the Anchorage Parking Authority twenty-four (24) hours prior to removal.

Article 2.3 Measurement

Removal and resetting of existing parking meters shall be measured per each parking meter post assembly, reset and accepted in final position. Parking meter and post components damaged or destroyed due to the Contractor's operation shall be replaced by the Contractor at no additional expense to the Owner. One post equipped with two or more parking meters shall be considered a single parking meter assembly.

Article 2.4 Basis of Payment

Payment for this Work shall be in accordance with Division 10, Section 10.07 - Measurement and Payment, and shall include full payment for all Work described in this Section.

Payment shall be made under the following unit:

ITEM	UNIT
Remove and Reset Parking Meter	Each

SECTION 85.03 TRAFFIC MARKINGS

Article 3.1 General

The Work under this Section shall consist of performing all operations pertaining to furnishing all materials; placing painted and methyl methacrylate traffic markings, anti-skid aggregate, and applying glass spheres thereto; and retroreflective preformed patterned pavement tape traffic markings. Contractor shall provide all Work in accordance with these specifications; at the locations shown on the Drawings; the Manual of Uniform Traffic Control Devices (MUTCD), and the Alaska Traffic Manual.

This work shall include applying markings to curb and median nose at locations shown on the Drawings.

Article 3.2 Materials

A. Paint for Traffic Markings - General Requirements

1. The Contractor shall furnish the name of the company that will manufacture the paint and the location of the plant from where shipments will be made. No material shall be shipped by the manufacturer until it has been sampled, tested, and approved.
2. Traffic Lane Paint shall conform to the current State Specifications.

B. Anti-Skid Aggregate

Anti-skid aggregate shall conform to the current State Specifications.

C. Glass Spheres for Reflectorizing Highway Pavement Markings

Reflective Glass Beads shall conform to the current State Specifications, and shall be supplied with a moisture-resistant coating.

D. Methyl Methacrylate Pavement Markings

1. General Requirements:
 - a. Contractor shall furnish Methyl methacrylate traffic markings which are manufactured and formulated from new material and are free from defects and imperfections that might adversely affect the serviceability of the finished product. Contractor shall furnish Traffic markings free from dirt and other foreign material such as, but not limited to, surface oils or existing road marking material, and shall cure to a tough serviceable film within the time specified by the manufacturer.
 - b. Methyl methacrylate traffic markings which are a spray-applied, ambient temperature curing, 2-component system for application on either asphalt or cement concrete surfaces. Traffic markings shall be composed of a Part "A" methyl methacrylate based resin and Part "B" benzoyl peroxide in liquid plasticizer. The mix ratio shall be four (4) parts of "A" to one (1) part of "B."
 - c. Methyl methacrylate traffic markings for extruded application shall be formulated with factory intermixed beads and anti-skid aggregate, and application of additional surface beads.

- d. Glass beads for drop-on applications recommended in writing by the traffic marking material manufacturer and approved by the Engineer.
- e. Skid resistance of methyl methacrylate traffic markings shall have a minimum British Pendulum number of 45 units, as determined by the current requirements of ASTM E303.
- f. Contractor shall furnish Methyl methacrylate traffic markings Dura-Stripe Type V manufactured by:

TMT – PATHWAY	Phone: 800-835-3357
1675 Commercial Street N.E.	FAX: 800-774-8464
Salem, Oregon 97303	or an approved equal.

Article 3.3 Construction

A. General

This Work shall be done as soon as possible after paving is completed to facilitate traffic.

B. Paint Color

All pavement markings shall conform to the colors shown on the Drawings.

C. Preparation of Surface

Paint will not be applied to pavements which are excessively dirty, damp, or cold. Paint shall be applied when the pavement temperature is at least forty degrees Fahrenheit (40°F) and rising, or per manufacturer’s recommendation. All dirt, oil, grease, and other foreign matter shall be removed from the areas of the pavement upon which the traffic markings are to be painted by a method approved by the Engineer.

D. Types of Lines

The type and color of the lines shall be as shown on the Drawings.

E. Width of Lines

The width and spacing of all lines shall be shown on the Drawings.

F. Application

1. Paint

- a. The paint shall be applied with atomizing spray type striping machine, approved by the Engineer. The markings shall have clear-cut edges, true and smooth alignment and uniform film thickness. The wet film thickness shall be twenty (20) mils with a nominal variation not to exceed two (2) mils.
- b. The wet film thickness of the in-place paint shall be measured as follows:
 Convenient to the location where the road service lines will be placed, test lines shall be laid to adjust the pavement-marking machine. In the

path of the test line laid without glass spheres, place a weighted sheet of aluminum foil eighteen by eleven inches (18" x 11"), thumbtacked to a three-quarter inch (3/4") plywood board. Immediately after the motorized striper (spraying a four inch (4") strip along the eighteen inch (18") dimension of aluminum foil) passes over the aluminum foil, quickly roll it up, slip an elastic band over the roll, and weigh it to the nearest 0.1 gram within thirty (30) seconds from the net weight of paint on the foil and the weight per gallon of the sample, calculate the film thickness using the following formula:

$$\begin{aligned} \text{Film thickness, in} &= \frac{A \times 231}{453.6 \times 18 \times 4 \times B} && \text{Where: } A = \text{Weight of paint} \\ & && \text{on foil in grams.} \\ &= \frac{A \times 0.007073}{B} && B = \text{Weight per gallon} \\ & && \text{of sample in pounds.} \end{aligned}$$

- c. Curb markings shall be defined as colored markings on the curb that denote parking restrictions. Marking material shall be applied to the top and face of curb, but not to the gutter.

2. Glass Beads

Glass beads shall be applied over the wet painted stripes in a uniform pattern at the rate of five pounds (5 lbs) of glass beads per gallon of paint. The bead dispensers shall be of a type that will mechanically and automatically give such performance. Glass beads shall be applied to all painted traffic markings by the drop-on method.

3. Methyl Methacrylate

- a. Contractor shall prepare the roadway areas to receive the methyl methacrylate pavement markings in accordance with this Section and the manufacturer's recommendations. Contractor shall submit a current copy of manufacturer's recommendations at least 5 working days prior to application of traffic markings.
- b. Contractor shall apply methyl methacrylate pavement markings as identified in the Contract Documents. The thickness is measured without glass beads.
- c. Contractor shall provide a manufacturer's representative to be present on the first day of striping for each type (sprayed or extruded) and additional days as required by the Engineer.
- d. Contractor shall not apply striping to new asphalt/P.C.C. until the asphalt/P.C.C. has cured to the satisfaction of manufacturer's representative or the Engineer.
- e. The minimum application rate of beading on sprayed markings is twenty pounds (20 lbs) of beads per gallon and twelve pounds (12 lbs) of beads per one hundred (100) square feet for extruded markings.
- f. During marking material application, anti-skid aggregate will be evenly distributed and visible throughout the top 20 mils of the marking material mixture, and after the application, in the surface of the cured material.

- g. The surface temperature of the roadway shall be in the range of 30° to 105° Fahrenheit for stripe application. Contractor shall thoroughly clean and dry the roadway surface.
- h. Contractor shall apply methyl methacrylate stripe material with equipment designed and capable of properly mixing at the point and time of application in accordance with the manufacturer's recommendations.

G. Pavement Marking Removal

Pavement markings shall be removed to the fullest extent possible from the pavement by any method that does not materially damage the surface or texture of the pavement or surfacing. Sand or other material deposited on the pavement as a result of removing traffic stripes and markings shall be removed as the Work progresses. Accumulations of sand or other material which might interfere with drainage or might constitute a hazard to traffic are not permitted.

Pavement markings no longer applicable which may create confusion in the minds of motorists shall be removed or obliterated before any change is made in the traffic pattern. Painting over markings is prohibited.

When the removal of any portion of a crosswalk marking is required, the entire crosswalk marking for the full width of the roadway shall be removed and replaced with the same material and depth identified in the drawings.

Pavement markings shall be removed by such methods that will cause the least possible damage to the pavement or surfacing. Any damage to the pavement or surfacing caused by pavement marking removal shall be repaired by the Contractor at their expense by acceptable methods.

Where blast cleaning is used for the removal of pavement markings or for removal of objectionable material, and such removal operation is being performed within ten feet (10') of a lane occupied by public traffic, the residue, including dust shall be removed immediately after contact between the sand and the surface being treated. Such removal shall be by a vacuum attachment operating concurrently with the blast cleaning operation, or by other approved methods.

H. Preliminary Spotting

The Contractor will provide the necessary pavement marking control points at 50 foot intervals and all changes of direction or changes in basic configuration. These points shall be used in preliminary spotting of lines before striping is commenced. The Contractor shall be responsible for preliminary spotting of pavement markings and must obtain approval from the Engineer before work on permanent pavement markings may begin. Examples of pavement markings subject to spotting include, but are not limited to, longitudinal lines, crosswalks, stop bars, symbols, and letters.

I. Inlaid Protected Markings

Apply with certified extrusion equipment. Grind the slot to the depth indicated in the Contract Documents and the dimensions specified, using a grinder capable of grinding the slot to the specified depth and width in a single pass. After grinding, obtain approval before placing marking material.

Dispose of asphalt grinding according to applicable federal, state, and local regulations.

Thickness of Inlaid Marking Material. Fill inlay area completely from the bottom of the inlay to the surface of the pavement. Do not overfill the slots.

Install markings in the same work shift as the grooving operation. Markings will be measured flush with the pavement surface, unless otherwise approved by the Project Inspector and Traffic Engineer.

J. Tolerances of Lane Striping

The Contractor shall keep their work within the following allowable tolerances:

1. Length of Stripe. The longitudinal error within a forty foot (40') length of lane line shall not be more than plus or minus six inches ($\pm 6''$).
2. Width of Stripe. The width of stripe shall not vary more than plus or minus one-half inch ($\pm 1/2''$).
3. Lane Width. The width of lanes shall not vary more than plus or minus four inches ($\pm 4''$) from the widths shown on the Drawings, measured from the edge of pavement or edge of traveled way to center of lane line or between the centers of adjacent lane lines.
4. Stripes on Tangents. Stripes on tangents shall not vary more than plus or minus one inch (1'') laterally within a distance of one hundred feet (100') when using the edge of the stripe as reference.
5. Stripes on Curves. Stripes on curves shall be uniform in alignment with no apparent deviations from the true curvature.
6. All Stripes. All stripes shall remain within four inches (4'') from the planed alignment when measured to the center of the stripe.
7. Depth of Inlay Slot. Depth of material shall be measured from the peaks created by the grooves to the visible surface of the markings. Minimum depth shall be as identified in the Contract Documents with a nominal variation not to exceed forty (40) mils.

Traffic markings not within the above tolerances will be considered unacceptable under this Section and shall be replaced by the Contractor at no additional cost to the Municipality.

Article 3.4 Measurement

Traffic markings shall be measured by linear foot of traffic marking of the specified width and color complete in place and accepted. Traffic markings consisting of words, symbols, and curb nose markings shall be paid per item complete in place and accepted.

Removal of traffic stripes and pavement markings as well as repair of any damaged pavement or surfacing caused by the pavement marking removal operations shall be incidental to other items of Work.

Payment for traffic markings is full compensation for preparing and cleaning of pavement, application of painted traffic markings, applying anti-skid aggregate, and

applying glass beads or spheres thereto, furnishing paint, anti-skid aggregate, glass beads, and all other material and equipment necessary to complete the Work described in this Section.

Article 3.5 Basis of Payment

Payment for this Work shall be in accordance with Division 10, Section 10.07 - Measurement and Payment, and shall include full payment for all Work described in this Section.

Payment shall be made under the following unit:

ITEM	UNIT
Traffic Markings (Type) (width)	Linear Foot
Traffic Markings (Type) (words & symbols)	Each
Inlaid Traffic Markings (Type) (width) (depth)	Linear Foot
Inlaid Traffic Markings (Type) (words & symbols) (depth)	Each
Curb Markings (Type)	Linear Foot
Curb Nose Markings (Type)	Each

SECTION 85.04 STANDARD SIGNS

Article 4.1 General

This Work shall consist of furnishing and installing signs, guide markers, object markers and mileposts. The sign location and type of installation will be as shown on the Drawings or as directed by the Engineer. Work under this Section shall also include removal and relocation, as well as removal and disposal of existing signs, mileposts, and markers. Work under this Section shall also include removal and resetting of sign post assemblies to original location or as directed by the Engineer.

Article 4.2 Materials

Fabricate all standard regulatory, warning, and guide signs for permanent installation with Type XI reflective sheetings that conform to ASTM D4956 and single-span aluminum panel substrates, unless designated otherwise on the Drawings.

All orange construction and maintenance signs shall be fabricated with Type XI (encapsulated lens) reflective sheeting.

All new standard signs for permanent installation shall be of new materials. All sign layouts shall be in accordance with "Alaska Sign Design Specifications." Any sign delivered or installed which does not conform to these specifications shall be replaced by the Contractor at no additional cost to the Municipality.

Concrete for sign post foundations shall conform to Class B-3 per Division 30, Section 30.01, Article 1.4 - Mix.

In the following specifications, a sign's height and width refers to an installed sign's vertical and horizontal dimensions, respectively, and to the length of the sides for diamond shaped signs.

A. Aluminum Sheet

Contractor shall provide sheet aluminum sign panels in one of the following alloys: 6061-T6, 5052-H36, or 5052-H38 that conform to ASTM B209. The thickness of the aluminum sheet shall be 0.125 inches unless otherwise specified. Alloy and temper designations shall be verified by mill certification.

Treat the aluminum base metal sheets with a conversion coating for aluminum conforming to ASTM B921 or ASTM B449, Class 2 standards. The cleaned and coated base metal shall be handled only by mechanical device or by operators wearing clean cotton or rubber gloves. After the cleaning and coating operation, the panels shall be protected at all times from contact or exposure to greases, oils, dust, or other contaminants.

Use single piece sign panels for all signs up to 48 inches by 72 inches. For signs with one or both dimensions larger than the base 48 inch by 72 inch sign panel, assemble multiple single-piece sign panels according to the following:

Use single piece sign panels for all signs 72 inches or less in the horizontal direction. For larger signs, assemble multiple piece sign panels with vertical seams only. Horizontal seams are only permitted when the height of the panel exceeds 72 inches.

B. Sheet Reflective Materials

Use reflective sheetings that are part of a matched component system made by a single manufacturer. The system shall include the sheetings, process colors, clear coatings, sealants, electronically cuttable films, protective overlay films, and recommended application equipment.

The sheetings shall also pass all performance requirements specified in ASTM D4956 for type XI reflective sheetings, when tested according to the methods specified therein, including the supplementary fungus resistance requirement.

The sheeting manufacturer shall furnish third party test results that verify their sheeting materials meet all performance requirements of ASTM D4956. If the results of the accelerated outdoor weathering test are not yet available, furnish the results of the supplementary artificially accelerated weathering test and provide the date the regular test results will be available.

Furnish reflective sheetings with a class 1 adhesive backing that meets the requirements of ASTM D4956.

Fabricate signs according to the manufacturer's written recommendations, using the process colors, coatings, sealants, and films made by the manufacturer of the reflective sheetings, and the application equipment recommended by the sheeting manufacturer.

Apply the reflective sheetings with no splices to those aluminum panels that can be oriented to fit on a rectangle with the smaller dimension equal to or less than forty-eight inches (48"). For all other sign panels, apply the reflective sheetings to form butt splices oriented to most efficiently utilize the sheeting material, except no splices are allowed within two inches (2") of the edge of a sign and in the length of reflective sheetings.

When making the butt splices, match the adjacent pieces as recommended by the manufacturer to assure uniform day color and night appearance. Provide a gap up to one-sixteenth inch (1/16") wide between the pieces of reflective sheeting.

Use single piece reflective sheeting on sign panels 48 inches or less in height or width. For larger signs, butt splicing of reflective sheeting is permitted except that splices are not permitted within two inches of the edge of the sign panel.

C. Letters, Numerals, Arrows, Symbols, Border

Letters, numerals, arrows, symbols, border, and other features of the sign messages shall be of the type, size, and series as specified by the Alaska Traffic Manual, the Anchorage Traffic Manual Addendum, or the Alaska Sign Design Specifications.

Completed letters, numerals, and other units shall be formed to provide continuous stroke width with smooth edges and shall present a flat surface free of warp, blisters, wrinkles, burrs, and splinters.

Fabricate the legend on signs using one of the following processes. For signs fabricated using the two screened processes, apply a clear coat over the entire face of each sign using a manufacturer recommended product.

For signs with a black legend, apply opaque black ink to form the legend on the reflective sheeting using the silk screened process.

For signs with a white legend on a colored background, apply transparent ink to all areas of the white reflective sheeting, except the legend, to form the background using the reverse silk screened process.

Apply electronically cut colored films that include adhesive to the reflective sheeting, similar to 1 and 2.

Cut the legends from the requisite color of type XI reflective sheetings and apply them to the reflective sheeting. Orient all elements of the legend in the same direction on the reflective sheeting before cutting them out.

D. Frames

All rectangular signs, over forty-eight inches (48") measured along the horizontal axis, and all diamond shape signs with a long edge forty-eight inches (48") or larger shall be framed unless otherwise specified. The frames shall be constructed of aluminum as indicated on the Drawings. All framing dimensions shall have a one-eighth inch (1/8") tolerance unless otherwise specified. The frame shall be affixed to the sign with three-sixteenth inch (3/16") diameter aluminum rivets. The maximum rivet spacing shall be twelve inches (12") on centers. No rivets shall be placed closer than three-eighths inch (3/8") from the edge of the aluminum face sheet.

Use framing members made from aluminum alloy 6061-T6. All joints of the aluminum frame may be welded with an inert gas shielded - arc welding process using 4043 electrode filling wire in accordance with good shop practice. The width of the fillet shall be equal to the wall thickness of the smallest framing member being welded.

E. Test Procedures and Inspections

1. Adherence

The test panel, after a 72-hour curing time, shall be immersed in 95°F. +3° water for a period of 24 hours. Immediately after removal from the bath, the reflective sheeting shall be sufficiently bonded so that it cannot be readily removed from the aluminum surface with a one inch (1") round nose spatula. If the sheeting can be peeled rather than chipped from the surface, the bond is considered unsatisfactory.

2. Solvent Resistance

Test shall be in accordance with Federal Specification L-S300B 4.3.6

3. Accelerated Weathering

Test shall be in accordance with Federal Specification L-S 300B 4.3.9.

4. Resistance to Heat, Cold, and Humidity

Test shall be in accordance with Federal Specification L-S-300B 4.3.10.

5. Tensile Strength and Elongation

Test shall be in accordance with Federal Specification L-S 300B 4.3.15.

F. Post Materials

Provide sign posts that conform to the following specifications for installing the post mounted signs specified in the Drawings.

Perforated Steel Posts.

1. For sign posts, install perforated steel tubes that conform to ASTM A653. Provide tubes fabricated from 0.105 inch thick (12 U.S. Standard Gauge) sheet steel zinc coated on both sides to minimum coating thickness designation G-90. Furnish tubes formed with square cross sections and sheet steels rolled from structural grade steel with 50 ksi yield strength.
2. All tubes shall be perforated along the centerline of each side for their entire length with seven-sixteenth inch (7/16") diameter holes on one inch (1") centers. All perforations shall be free from burrs.
3. Furnish perforated tubes that are straight and feature a smooth, uniform finish without splices. Consecutive one-quarter inch (1/4") size tubes shall telescope freely for a minimum length of ten feet.
4. Furnish the tube sizes specified in the Drawings in lengths that will provide one-piece sign posts when the signs are installed according to the Standard Details that apply, regardless of ground cross section.

Article 4.3 Construction

All sign post foundations shall be cast in excavated holes. Depth of embedment shall be as shown on the Standard Details unless otherwise directed by the Engineer.

Contractor shall dispose of surplus excavated material in accordance with Division 10, Section 10.04, Article 4.9 - Disposal Sites.

Concrete sign post shall be plumb to the ground after the concrete has fully cured.

Cut each perforated tube to provide the sign mounting-height specified in the Section 85 detail that applies. Adjust each tube length to account for the height of the signs, the difference in elevation between the mounting height reference and the top of the foundation, and the one foot length inserted into the foundation. Remove all burrs from the cut end.

Guide Marker reflectors shall be installed after the posts have been set in place.

Sign panels shall be attached to posts, electroliers, traffic signal standards, bridge rails, piers, and abutments with fastening hardware of the types and sizes shown on the Standard Details. On non-frame mounted signs attached to signal pole mast arms the Contractor shall install two inch (2") diameter wind washers, colored to match the sign face, between the fastener head and the sign. Use rust-resistant washers fabricated from a material equal in strength to the sign blank. All fastening hardware shall be furnished by the Contractor. All signs shall be mounted so that they are level.

Attach a label to the back of all standard signs in the lower right corner. Make the label at least 15 square inches and show the year the sign was installed by the Contractor. Show the last two digits of the year in clear and bold numbers. Make the label from ASTM D4956 Type I or brighter retroreflective sheeting. Use background and legend colors meeting the following table.

YEAR	BACKGROUND COLOR	LEGEND COLOR
XXX1	Yellow	Black
XXX2	Red	White
XXX3	Blue	White
XXX4	Green	White
XXX5	Brown	White
XXX6	Orange	Black
XXX7	Black	White
XXX8	White	Black
XXX9	Purple	White
XXX0	Strong Yellow-Green	Black

Central Values and tolerance limits for each color, as referenced in the MUTCD, are available from the Federal Highway Administration, (HHS-30), 400 7th St. SW, Washington, D.C. 20590

Contractor shall prune overhanging limbs and other vegetation to ensure visibility of signs as shown on Standard Detail 85-31. All clearing activities shall be performed by an arborist in accordance with Section 20.05 Clearing.

Removed and relocated existing signs and mile posts shall be placed on a new sign post foundation base and shall conform to the Drawings or as directed by the Engineer.

Sign post foundation bases from removed or salvaged signs shall be removed and the ground restored to match the surrounding area. Restoration is considered incidental to the sign bid item.

Contractor shall salvage and deliver signs, posts, and associated hardware designated on the Drawings for Salvage to the Municipal Traffic Sign Shop, 343-4384. Contractor shall remove sign from post before removal and delivery to the Municipal Traffic Sign Shop. Contractor shall remove the sign(s) and associated hardware without damaging the post or sign face. Contractor shall replace sign components damaged or destroyed due to Contractor's operations at no cost to the Municipality.

Inspection: All materials and finished signs are subject to inspection and acceptance in place. All surfaces exposed to weathering shall be free of any defects in the coating that may impair the serviceability or detract from the general appearance or color match. The finished signs shall be clean and free from all chatter marks, burrs, sharp edges, loose rivets, delaminated reflective sheeting, and aluminum marks. No repairs shall be made to the face sheet. All signs not conforming to these Specifications shall be rejected and shall be replaced by the Contractor at no additional expense to the Municipality.

Article 4.4 Measurement

The quantity of Standard Regulatory, Warning, and Guide Signs for permanent installation to be paid for shall be the total square footage of each face of legend bearing sign and panel erected in place, including all posts, bases, and all hardware necessary to install the sign(s) at the designated location. No deductions in quantity for corner rounding shall be made. Nominal dimensions for sign sizes indicated on the Drawings shall be used for the purpose of calculating sign pay quantities.

Clearing for signs shall be incidental to work under this Section unless specifically identified for payment under a separate bid item.

Removal and relocation of existing signs, posts, bases, and all hardware necessary to install the sign at the designated location shall be measured per each sign, completed and accepted in final position. Sign components damaged or destroyed due to the Contractor's operation shall be replaced by the Contractor at no additional expense to the Owner. Object Markers and Guide Markers shall be measured per each, complete in place. One post equipped with two reflectors shall be considered a single marker. One signpost equipped with two or more signs is a single sign assembly.

Salvage of existing signs, posts, bases, and all associated hardware and delivery to the Sign Shop shall be incidental to the Contract unless the bid item "Salvage Sign" is provided in the Bid Proposal.

Article 4.5 Basis of Payment

Payment for this Work shall be in accordance with Division 10, Section 10.07 - Measurement and Payment, and shall include full payment for all Work described in this Section.

Payment will be made under the following units:

ITEM	UNIT
Standard Sign	Square Foot
Remove and Relocate Signs	Each
Remove and Relocate Mile Posts	Each
Salvage Sign	Each

SECTION 85.05 TRAFFIC MAINTENANCE

Article 5.1 General

The Work under this Section consists of performing all the necessary measures to protect and control traffic during the life of the individual project including, but not limited to, furnishing, erecting, maintaining, replacing, cleaning, moving and removing the traffic control devices, construction signs, portable concrete barriers, safety fences, and flagging required to safeguard the traveling public and all administrative responsibilities necessary to implement this Work.

The Contractor shall maintain all roadways, pedestrian, transit, and bicycle facilities within the project limits, and construct and maintain such approaches, crossings, intersections, and other features as may be necessary throughout the life of the Contract. The Contractor shall also have a powered broom (pick-up sweeper type) and water truck with high-pressure capabilities to clean the paved surfaces and along the haul routes.

A Traffic Control Plan (TCP) is required for this project. The Contractor shall provide a TCP approved by the Traffic Engineer or their designee, and when the project limits include State right-of-way, the Alaska Department of Transportation and Public Facilities (ADOT&PF) Regional Traffic Engineer prior to commencement of this project in accordance with the provisions of Division 10, Section 10.04, Article 4.13 - Traffic Control Plan. The Contractor may submit approved amendments to the TCP prior to commencement of the project. All approvals shall be obtained by the Contractor and shall be considered incidental to the Contract and no separate payment shall be made. When the project limits include state right-of-way, the Contractor shall notify ADOT&PF at least 48 hours before commencing construction.

The Contractor is required to have at least one International Municipal Signal Association (I.M.S.A.) or American Traffic Safety Services Association (A.T.S.S.A.) certified person on the job site during working hours for traffic control and implementation. The person designated will supply the Traffic Engineer with a 24-hour emergency telephone number.

All traffic channelization, detours, lane closures and/or street closures shall conform to the TCP and Division 10, Section 10.04, Article 4.13 - Traffic Control Plan.

Article 5.2 Traffic Control Plan

A TCP is a graphic/text plan that describes traffic control to be used to assist road and non-motorized facility users (drivers, bicyclists, and pedestrians, which include people with disabilities) through a temporary traffic control zone or an incident area. The degree of detail in the TCP depends on the nature and complexity of the project. The TCP may include, but not be limited to, such items as signs, portable concrete barriers, barricades, traffic cones, special signs, warning lights, portable changeable message board signs, flaggers, pilot cars, work zone pavement markings, temporary roadways, and all other items required to direct traffic through or around the construction zone in accordance with these specifications, the Manual on Uniform Traffic Control Devices (MUTCD), published by the US Department of Transportation, the State of Alaska Traffic Manual (ATM), and the Alaska Sign Design Specifications (ASDS). These TCPs shall also address placement of traffic control devices including location, size, mounting

height, and type. The details shown for signs shall include the code designation, size, and legend in accordance with the ATM and the Alaska Sign Design Specifications (ASDS). The TCP shall also indicate the method of safely routing pedestrian and bicycle traffic through or around the construction zone.

If any part of the Contractor's project impacts on-street parking in the Central Business District (the boundaries of which are defined in the Anchorage Municipal Code) from Monday through Saturday, the Contractor must apply for a Parking Meter Hood Contract from EasyPark (or Successor entity). Proof of parking meter rental agreement must be provided to the Traffic Engineer prior to issuance of an approved TCP.

The Contractor shall submit a TCP for the project prepared and signed by a certified traffic control designer. The TCP shall be approved by the Traffic Engineer and, if the Traffic Engineer determines that a state route is affected by the TCP, approved by the State of Alaska, Department of Transportation and Public Facilities Regional Traffic Engineer. The Contractor shall respond and make field changes as the Traffic Engineer directs.

In cases of emergency road closures or excavations, the Contractor may commence work without an approved TCP. All traffic control for the emergency work shall be done in compliance with all applicable federal, state, and municipal rules and regulations. The Contractor shall secure a permit and approved traffic control plan on the next working day after implementation of emergency traffic control.

No Work shall occur within rights-of-way or easements for public streets, highways, or other public improvement projects until the Contractor has implemented an approved TCP for the Work proposed. The number of signs indicated on the TCP is a minimum. If unsafe conditions occur, the Traffic Engineer may require additional signs/devices at no additional cost to the Owner.

Article 5.3 Pedestrian Traffic

The Contractor shall provide pedestrian access in accordance with the requirements of Division 10, Section 10.04, Article 4.10 - Protection of Persons, Property and Environment, and Article 4.12 - Public Convenience and Access, and the current Accessibility Guidelines for Pedestrian Facilities in the Public Right-of-Way (PROWAG).

The Contractor shall provide and maintain a pedestrian traffic route through and/or around the Project for the duration of the Project or until a permanent pedestrian walkway has been completed. The route shall be signed and delineated such that it is obvious and recognizable to the pedestrian and include proximity actuated audible signs or other non-visual means of conveying information on the signs. The route shall be established in a location within or near the Project limits, at a distance which will help to eliminate interference between pedestrians and construction operations. The location of the route may change throughout the duration of the project, depending on locations of construction operations, and each location shall be approved by the Traffic Engineer. 4-foot high construction orange safety fencing shall be required along the pedestrian route as necessary to separate work zone from the pedestrian route.

Article 5.4 Work Site Traffic Supervisor

The Contractor shall provide a Work Site Traffic Supervisor whom shall be responsible for the Contractor's maintenance of traffic operations on a 24-hour basis. The Work Site Traffic Supervisor shall meet the following minimum requirements:

1. Is currently certified as a Work Site Traffic Supervisor by the American Traffic Safety Services Association (A.T.S.S.A.); or
2. Is currently certified as a Work Zone Traffic Safety Specialist or a Work Zone Safety Specialist by the International Municipal Signal Association (I.M.S.A.); or
3. Is currently certified as a Work Site Traffic Technician by A.T.S.S.A.

If the individual is certified under Items 2 or 3 above, the Contractor shall submit, prior to Work requiring traffic control, documentation that the individual has also obtained:

1. A minimum of 12 months of supervisory level work in Work Site Traffic Control; or
2. One year of having been in responsible charge of such Work. The term "in responsible charge" shall be construed to mean having been in a position of accountability for the selection of devices and for their placement in the traffic control system, or for the continued operation of the system. Having persons that actually perform the labor under one's control would satisfy this requirement. Provide at least one reference, including current address and telephone number, for each project which "in responsible charge" experience is claimed.

The Work Site Traffic Supervisor's duties shall include the following:

1. Understand the requirements of the ATM, the Drawings, and the Specifications.
2. Prepare the TCPs and public notices and coordinate traffic maintenance operations with the Traffic Engineer.
3. Inspect the condition and position of all traffic control devices in use on the Project and ensure that all traffic control devices are in proper working order, clean, visible, and conform to the approved TCP in use. The inspection shall occur daily on smaller projects and more frequently on more complex projects. All devices shall be inspected during hours of darkness so that effectiveness of the device placement can be evaluated and adjustments made, if required, to afford maximum nighttime visibility and delineation. These inspections shall be documented in a bound field book. The field book shall be made available to the Engineer for review on a daily basis and shall become the property of the Engineer upon completion of the Work.
4. Supervise the repair or replacement of damaged or missing traffic control devices.
5. Review and anticipate appropriate traffic maintenance needs and ensure that the proper traffic control devices necessary for safe and efficient traffic movement are available.

6. Hold weekly traffic safety meetings with the superintendents and foremen of the Contractor and subcontractors prior to beginning construction. The Contractor shall provide the Traffic Engineer the opportunity to attend these meetings.

Article 5.5 Materials

Materials for traffic control devices shall conform to the requirements set forth below:

1. Signs. Permanent Construction Signs, Construction Signs, and Special Construction Signs including sign supports shall conform to the requirements of Section 85.04 - Standard Signs, ADOT&PF Standard Specifications for Highway Construction; the ATM; and the Alaska Sign Design Specifications (ASDS).
2. Proximity Actuated Audible Signs. Contractor shall provide proximity actuated audible signs conforming to the requirements of PROWAG for conveying information of alternate pedestrian access routes in advance of decision points to pedestrians with visual disabilities.
3. Portable Sign Supports. Contractor shall provide portable sign supports that are wind resistant with no external ballasting and capable of supporting a forty-eight by forty-eight inch (48" x 48") traffic control sign such that the height of the sign above the adjacent roadway surface conforms to the ATM. The sign support shall support the traffic control sign vertically.
4. Barricades and Vertical Panels. Contractor shall provide barricades and vertical panels that are constructed of wood, metal, or plastic, and conform to the requirements of the ATM. Type III barricades shall have a minimum width of eight feet (8'). Contractor shall equip barricades with warning lights.
5. Warning Lights. Contractor shall provide Type A (low intensity flashing), Type B (high intensity flashing), or Type C (steady burn) warning lights conforming to the requirements of the ATM.
6. Drums. Contractor shall provide plastic drums conforming to the requirements of the ATM.
7. Traffic Cones. Contractor shall provide traffic cones and/or tubular markers conforming to the requirements of the ATM. The minimum height is twenty-eight inches (28"). All cones and tubular markers shall be reflectorized.
8. Portable Changeable Message Board Signs. Contractor shall provide portable, truck- or trailer-mounted, changeable message board signs with a self-contained power supply for the sign that has the following features:
 - a. Message sign panel large enough to display three lines of nine inch (9") high characters.
 - b. Eight-character display per message line.
 - c. Message modules containing at least 36 different preprogrammed messages (three line displays) to be selected by the Traffic Engineer.
 - d. The capacity to create, preview, and display new messages and message sequences.

- e. A waterproof, lockable cover for the controller keyboard.
 - f. An operator's manual, a service manual, and wiring diagram.
 - g. Quick release attachments on display panel cover.
 - h. Variable flash and sequence rates.
 - i. Manual and automatic dimming capability on lamp bulb matrix models.
 - j. Variable mounting height of at least seven feet (7') from the pavement to the bottom of the message sign panel.
 - k. The capacity to operate with a battery pack for two hours under full load.
9. Portable Concrete Barriers. Portable concrete barriers shall conform to the requirements of ADOT&PF Standard Plan G-47. Portable concrete barriers shall be equipped with warning lights.
10. Work Zone Pavement Markings. Work zone pavement markings shall be either painted with glass beads or preformed marking tape (removable or non-removable).

Article 5.6 Public Notice

The Work Site Traffic Supervisor shall give notices of changes, delays, or lane/road closures to the following local officials and transportation organizations including, but not necessarily limited to:

- 1. Alaska Trucking Association
- 2. Alaska State Troopers
- 3. Alaska Court System
- 4. Anchorage Police Department
- 5. Anchorage Fire Department
- 6. Local Emergency Medical Services
- 7. Anchorage Public Transportation
- 8. ASD Student Transportation
- 9. U.S. Postal Service
- 10. Local Schools and Universities
- 11. MOA Parks and Recreation
- 12. Local Solid Waste Utilities
- 13. Alaska Railroad (where applicable)
- 14. Major Tour Operators

The Contractor shall also provide the Alaska State Troopers, Anchorage Police Department, and Anchorage Fire Department with a list of radio frequencies and cellular telephone numbers used on the project, and the 24-hour telephone numbers of the Work Site Traffic Supervisor and the Project Superintendent. This contact information shall be for alerting the Contractor of emergencies which will require passage of

emergency vehicles through the project. When so notified, the Contractor shall use all equipment and effort necessary to expedite rapid passage.

Contractor shall provide proper notification to residents of impending construction activities for all projects. Contractor shall provide residents with contact name(s) and phone number(s) for Contractor personnel with responsibility to inform and coordinate with residents. The Contractor shall give written notice to the residents of any adjacent property having direct driveway or parking access to the project area, 48 hours in advance of installing curb and gutter, sidewalk, or approach aprons across the driveway, or driveways serving the adjacent property.

Advertisement and/or public notice requirements for closures shall be based on roadway classification in the Official Streets and Highways Plan (OSHP) for the Municipality of Anchorage.

On streets listed as minor arterials and higher, the Contractor shall provide a minimum advertised public notice of seven (7) days in advance of the closure and seventy-two (72) hours of "on site" notice. The notice shall contain the days, times, and locations of the closure. The Contractor shall advertise the closure through the Municipality of Anchorage's construction project and road closure website (www.anchorageroads.org).

On streets listed as collectors, Contractor shall provide a minimum of seventy-two (72) hours of "on site" notice prior to the closure.

No published advertisement is required on other streets.

The published advertisement shall be displayed through the www.anchorageroads.org website. The Contractor shall provide the Traffic Engineer with the Contractor's name, effective dates and times of the closure, and detailed traffic information. The Traffic Department may publish the information electronically on a weekly basis until the completion of the project. The "on site" advertisement shall consist of changeable message boards or similar approved notification to motorists and pedestrians. Contractor shall promptly cancel advertisements after the closure is completed or the traffic control is removed.

Article 5.7 Traffic Control Devices

Prior to the start of construction operations, the Contractor shall erect such permanent and temporary traffic control devices as may be required by the approved Traffic Control Plan (TCP). Traffic control devices shall be operated only when they are needed and only those devices that apply to conditions that exist shall be used. Advisory speeds, when necessary, shall be provided in the TCP and approved by the Traffic Engineer.

Following the completion of Work in a closure area, all traffic control devices relating to the closure shall be removed. Sign panels that are not removed shall be entirely covered with either metal or plywood sheeting.

The Traffic Engineer may require a different TCP specifically for winter shutdowns.

Contractor shall keep clean reflective sheeting on signs, drums, barricades, and other devices. Contractor shall promptly replace any devices with scratches, rips, or tears in the sheeting deemed unacceptable by the Engineer at no additional expense to the Owner.

Article 5.8 Authority of the Engineer

When, in the opinion of the Engineer, conditions are such that the safety and/or convenience of the traveling public are adversely affected, the Engineer will immediately notify the Contractor in writing. The notice will state the defects, the corrective actions required, and the time required to complete such actions. In no case shall this time exceed twenty-four (24) hours. In the event that the Contractor fails to take the corrective actions within the specified time, (a) the Engineer will immediately direct that the offending operations cease until the defects are corrected, and (b) the Engineer reserves the right to order the corrective actions be accomplished by outside forces. The Engineer will deduct the cost of Work by outside forces from any moneys due or that may become due under the terms of this Contract.

Article 5.9 Execution

The Contractor shall maintain traffic control in accordance with the approved Traffic Control Plan (TCP). The Contractor shall submit a new TCP each time traffic control is revised. Approval of each new TCP is required.

The Contractor shall furnish all traffic control devices necessary to fulfill the requirements of this specification, including construction signs, barricades, portable concrete barriers, safety fence, and flaggers. Said traffic control devices are considered incidental to this item. All such devices shall conform to the Alaska Traffic Manual (ATM). Paved road detours and gravel pedestrian detours are also incidental to this item.

The Contractor shall protect and adequately delineate open trenches, ditches, pavement edge drop-offs, and other excavations and hazardous areas with barricades as required by OSHA. Open trenches with drops of two feet (2') or greater adjacent to the roadway shall have portable concrete barriers installed with sloping end(s). All barricades and portable concrete barriers in place at night shall have warning lights installed in accordance with the ATM.

Unless otherwise provided hereinafter, the Contractor shall maintain all roadways open to traffic. Temporary closure of residential, commercial, or street approaches requires prior approval of the Engineer. The Contractor shall provide access through and around the project for emergency vehicles. Contractor shall properly sign and/or flag all locations requiring redirection or stopping of the traveling public.

The Contractor's equipment shall stop at all points of intersection with the traveling public unless satisfactory traffic control measures, approved in writing by the Engineer, are installed and maintained by the Contractor.

Where required on the Drawings, the Contractor shall bypass traffic over a paved detour route. When no longer required, the detour shall be removed and the approaches obliterated. Construction of the detour will be considered incidental to bid item "Traffic Maintenance."

The Contractor shall provide flagger(s) any time operations may affect safety, or as directed by the ATM or the Engineer. Unless approved by the Traffic Engineer on the TCP, flagger(s) are required at all times when one-lane traffic is in effect. All flagging operations shall conform to the procedures outlined in the ATM.

Article 5.10 Measurement

All Work in this Section is measured by lump sum and shall consist of all labor, materials, and equipment required to provide the Work Site Traffic Supervisor, all TCPs and TCP revisions, public notices, paved traffic detours, pedestrian and bicycle detours, and all traffic control devices. Work and materials required to provide temporary asphalt surfacing and temporary painted traffic markings shall not be paid separately and shall be considered incidental to the Work described in this Section.

Article 5.11 Basis of Payment

Payment for this Work shall be in accordance with Division 10, Section 10.07 - Measurement and Payment, and shall include full payment for all Work described in this Section.

Payment shall be made under the following unit:

ITEM	UNIT
Traffic Maintenance	Lump Sum

SECTION 85.06 REMOVE GUARDRAIL

Article 6.1 General

The Work under this Section consists of providing all operations and furnishing all equipment and materials pertaining to the removal and disposal of guardrail designated for removal on the Drawings or as directed by the Engineer.

Article 6.2 Construction

Contractor shall remove the guardrail, bolts, and supporting posts and deliver them to a location as directed by the Engineer. If guardrail and supporting posts are not salvaged, Contractor shall provide a disposal site for the removed guardrail, bolts, and supporting posts in accordance with the provisions of Division 10, Section 10.04, Article 4.9 - Disposal Sites.

Excavation and backfill required in the removal of the guardrail, bolts, and supporting posts is incidental to the bid item. Contractor shall backfill the excavation with native non organic material.

Article 6.3 Measurement

Removal and salvage or disposal of the guardrail, bolts, and supporting posts is measured per linear foot along the face of the guardrail. Delivery of guardrail and associated components to Engineer-designated location or disposal at Contractor furnished disposal site is incidental to the pay item and no additional payment will be made.

Article 6.4 Basis of Payment

Payment for this Work shall be in accordance with Division 10, Section 10.07 - Measurement and Payment, and will include full payment for all Work as described in this Section.

Payment is made under the following unit:

ITEM	UNIT
Remove Guardrail	Linear Foot

SECTION 85.07 GUARDRAIL

Article 7.1 General

The Work under this Section consists of providing all operations pertaining to the construction of guardrails.

Only one type of material shall be used on any one specific guardrail installation, unless otherwise approved by the Engineer.

Article 7.2 Material

- A. Steel rail elements shall conform to the requirements of AASHTO M 180, Class B, unless a lighter weight rail is specifically called for on the Drawings or in the Specifications. Terminal sections shall not be less than twelve (12) gauge.
- B. The bolts and nuts shall be galvanized steel and shall conform to the requirement of ASTM A153, Class C and ASTM A307.
- C. Guardrail posts shall be of either wood or steel as specified.
 - 1. Wood posts shall be grade posts and timbers, or better, as rated by the West Coast Lumber Inspection Bureau, and shall be fabricated from one of the following timber species, unless otherwise approved: a) Douglas Fir; b) Western Pine; c) Larch, or; d) Hemlock. The length and cross-section of the posts shall be as shown on the Standard Details unless otherwise noted. Timber posts shall be treated with one of the following preservative treatments: a) Pentachlorophenol; b) Creosote Oil; c) Creosote-coal tar solution; or d) Creosote-petroleum solution. Preservative treatments for wood shall conform to the applicable requirements of AASHTO M 133.
 - 2. Steel posts shall be of the section and length as specified or as shown on the Drawings. They shall be of copper bearing steel when so specified. Steel shall conform to the requirements of ASTM A36 for the grade specified, or, for new railroad rail posts, of ASTM A1 for the unit weight of rail specified.

The posts shall be galvanized or shop painted as specified.

Article 7.3 Construction

The construction of guardrails shall be in conformance with the manufacturer's recommendations, the Standard Details, and as directed by the Engineer.

Article 7.4 Measurement

Guardrails will be measured per linear foot along the face of the rail, including end sections.

Article 7.5 Basis of Payment

Payment for this Work shall be in accordance with Division 10, Section 10.07 - Measurement and Payment, and shall include full payment for all Work described in this Section.

Payment shall be made under the following unit:

ITEM	UNIT
Guardrail (Gauge)	Linear Foot

SECTION 85.08 TEMPORARY GROUP MAILBOXES

Article 8.1 General

The Work under this Section consists of performing all operations pertaining to constructing and maintaining a temporary group of mailboxes for the duration of construction.

Article 8.2 Materials

Contractor shall furnish nails, staples, fastening wires, lumber, and all materials required for construction of the mailboxes.

Article 8.3 Construction

The temporary group mailboxes shall be provided by the Contractor prior to pavement removal. Temporary group mailboxes shall conform to current U.S. Postal Service standards.

Article 8.4 Measurement

Temporary group mailboxes shall be measured by lump sum.

Article 8.5 Basis of Payment

Payment for this Work shall be in accordance with Division 10, Section 10.07 - Measurement and Payment, and shall include full payment for all Work described in this Section.

Payment shall be made under the following unit:

ITEM	UNIT
Temporary Group Mailboxes	Lump Sum

SECTION 85.09 RELOCATE MAILBOX

Article 9.1 General

The Work covered under this Section consists of performing all operations pertaining to the removal and resetting of mailbox(es) and cluster mailbox(es) affected by construction of this project, and shall include providing temporary mailbox(es). The Engineer will designate which mailbox(es) is/are affected. The term "mailbox" shall include cluster mailbox units and parcel boxes. Multiple cluster mailbox units or parcel boxes on one concrete pad shall be considered one cluster mailbox unit.

Article 9.2 Materials

Contractor shall salvage, from the existing mailbox(es), all reusable materials. Contractor shall replace materials that cannot be salvaged or are damaged by Contractor's operations, at Contractor's expense, with new materials, which as nearly as possible duplicate the kind, quality, and capacity of the original installation. USPS may request to replace existing cluster mailbox units or parcel boxes scheduled for relocation at USPS's expense, as coordinated with the Engineer in the field.

Contractor shall furnish nails, staples, fastening wires or devices, and all materials required for the construction of such anchors, posts, concrete pads, or other portions of the mailbox, which can be replaced more efficiently than they can be moved.

If the property owner elects to replace any of the existing mailbox materials with other materials in better condition, they will be responsible for furnishing and delivering such materials to the site of the Work.

Article 9.3 Construction

Contractor shall provide temporary mailbox placement and access. Contractor shall set the mailbox(es) in reasonably close conformity to its original location with respect to access points or as the Engineer directs. Contractor shall set posts and anchors at the same depth as in the original mailbox(es) or as directed by the Engineer. Contractor shall replace by equivalent construction permanent anchors, posts, or other parts that cannot be economically moved. Contractor shall paint new materials requiring painting. Contractor shall paint the entire mailbox and support if the paint on the new items does not adequately match or does not meet the satisfaction of the Engineer. Contractor shall place the relocated mailbox(es) in at least as good condition as the existing mailbox(es) before they were moved, behind the curb and gutter in accordance with postal regulations, or as the Engineer directs. Contractor shall place the face of the mailbox(es) forty-one to forty-five inches (41" to 45") above the roadway surface, behind the curb and gutter, or in an alternate location approved by the U.S. Post Office. Contractor shall install the cluster mailboxes in accordance with the manufactures instructions and the information provided in the plans.

Article 9.4 Measurement

Relocating mailboxes shall be measured per unit permanently relocated and complete in place. Each unit shall consist of a stand having a single mailbox or a variable number of mailboxes. No payment shall be made for temporary mailbox placement or relocation.

Relocating cluster mailbox units and parcel boxes shall be measured per unit permanently relocated and complete in place including all excavation, backfill, compaction, and grading necessary for construction. Multiple cluster mailbox units or parcel boxes on one concrete pad shall be considered one cluster mailbox unit and no separate payment shall be made. Concrete mailbox base and concrete backing curbs including rebar associated with cluster mailboxes and parcel boxes shall be measured in accordance with bid item 30.08 P.C.C. Cluster Mailbox Base.

Article 9.5 Basis of Payment

Payment for this Work shall be in accordance with Division 10, Section 10.07 - Measurement and Payment, and shall include full payment for all Work described in this Section.

Payment shall be made under the following unit:

ITEM	UNIT
Relocate Cluster Mailbox	Each
Relocate Mailbox	Each

SECTION 85.10 FLEXIBLE DELINEATORS

Article 10.1 General

The Work covered under this Section consists of providing all labor, materials, equipment, and transportation required for complete installation of Flexible Delineators.

Article 10.2 Submittals

Contractor shall submit three copies of manufacturer's product data for approval by the Engineer.

Article 10.3 Materials

The Flexible Delineators shall be made of composite material certified to withstand multiple vehicle impacts at high speeds, perform within the temperature extremes of the project location, be resistant to UV light and vandalism. The Delineator shall consist of a corrosion-resistant drivable ground anchor and replaceable tubular composite post, color as indicated in the plans, with reflective sheeting for nighttime visibility. Minimum outside diameter of the post shall be 2", minimum height 42".

The Delineator shall be a Carsonite Composites, Newberry, South Carolina, Model Utility Sentry CIP2 – round, or approved equal. To be considered equal, Delineators must be flexible, replaceable, and have the specified physical properties, dimensions, and color.

Article 10.4 Construction

Contractor shall install Delineators in accordance with the manufacturer's recommendations. Where anchors are embedded in concrete, the Contractor shall install the anchor so that the top of the anchor is flush with the concrete surface.

Article 10.5 Measurement

Delineators shall be measured as complete installations including the drivable ground anchor, replaceable composite post, and all labor required for the installation.

Article 10.6 Basis of Payment

Payment for this Work shall be in accordance with Division 10, Section 10.07 - Measurement and Payment, and shall include full payment for all Work described in this Section.

Payment shall be made under the following unit:

ITEM	UNIT
Furnish and Install Flexible Delineator	Each

SECTION 85.11 PERMANENT VERTICAL TRAFFIC CALMING DEVICES

Article 11.1 General

The Work under this section shall consist of furnishing all materials and performing all operations necessary to construct permanent vertical traffic calming devices on paved surfaces.

Article 11.2 Cross Section Template

Prior to construction, the Contractor shall submit two (2) cross-section templates for each type of device for approval by Engineer. One template shall be for the Contractor's quality assurance use, and the other shall be utilized by the Inspector. The Contractor shall construct templates of rigid materials such as wood or steel to match the vertical traffic calming device cross-section as shown on the Standard Details. The template will be used for checking the device cross-section for compliance during construction, and for final acceptance upon completion. The template shall be manually moved laterally down the length of the device to verify that the vertical traffic calming device matches the specified cross-section. Because the template will be used manually, it must be light weight but rigid enough to retain the specified cross-section shape during transport and use.

Article 11.3 Material

The vertical traffic calming devices shall be constructed of Class D asphalt pavement material as specified in M.A.S.S. Section 40.06 – Asphalt Concrete Pavement.

Article 11.4 Construction

Construct vertical traffic calming devices in accordance with M.A.S.S. Section 40.06 – Asphalt Concrete Pavement and the dimensions as detailed in the Drawings.

Equipment used in the construction shall conform to M.A.S.S. Section 40.06 – Asphalt Concrete Pavement.

Density and surface requirements shall conform to M.A.S.S. Section 40.06 – Asphalt Concrete Pavement.

Prior to constructing the traffic calming device, Contractor shall apply a layer of Tack Coat to the existing surface in accordance with M.A.S.S. Section 40.04 – Tack Coat.

The compacted pavement surface shall be within plus or minus one-fourth inch ($\pm 1/4"$) as shown in the plans. Non-conforming surfaces shall be subject to rejection by the Engineer.

Article 11.5 Measurement

The vertical traffic calming devices shall be measured per each complete device accepted in place, in accordance with Section 11.4 – Construction maximum and minimum tolerances, and as shown on the Standard Details. No separate measurement or payment will be made for asphalt, tack coat, pavement markings, templates, or other material required to construct each vertical traffic calming device as they are incidental to this Work item.

Article 11.6 Basis of Payment

Payment for this Work shall be in accordance with M.A.S.S. Division 10, Section 10.07 – Measurement and Payment, and shall include full payment for all Work described in this Section.

Payment shall be made under the following unit:

ITEM	UNIT
Sinusoidal Speed Hump	Each
Asphalt Flat Top Speed Hump	Each
Asphalt Speed Cushion	Each

SECTION 85.12 MULTI-MODAL COUNTERS

Article 12.1 General

The Work under this Section consists of the performance of all operations pertaining to furnishing and installing multi-modal pathway and sidewalk counters. The counter must differentiate between pedestrians and cyclists bi-directionally.

Article 12.2 Material

A. Multi-Modal Counter

Multi-Modal Counters shall consist of infrared sensors (located in posts), induction loops, conduit, and equipment housing, if required.

Contractor shall provide Urban MULTI Evo counter for sidewalk multi-modal counter installations and MULTI Evo Nature counter for pathway multi-modal counter installations, manufactured by:

Eco-Counter Canada/USA
604-3981 St-Laurent Boulevard
Montreal Quebec H2W1Y5, Canada
Phone: 1-866-518-4404
Website: <https://www.eco-counter.com/>

or an approved equal.

Article 12.3 Construction

A. Preparation

Prep work shall be coordinated with and overseen by the Traffic Department. Contact the Traffic Department (343-8053 or 343-8421) seven (7) working days prior to planned field installations.

1. Induction Loops:

- a. Check pre-formed induction loops to ensure there are no wire or housing defects.
- b. The Traffic Department shall perform induction loop test prior to installation. Inductance shall read between 100 and 150 microhenries (μH).

2. Post:

- a. Install conduit, post housing, and anchor base at least one (1) day prior to placement of post. Ensure anchor base is level and bolt pattern is correct for infrared sensor alignment and operation.

B. Field Installation

1. The Traffic Department shall be on-site for coordination and field installations. Provide Traffic Department twenty-four (24) hour notice of actual installations. Failure to notify the Traffic Department may result in delay of work and withholding of payment. The Owner may withhold from any progress payment the sum of \$500 per day as Liquidated Damages for each and every calendar day that the Contractor delays notification to the Traffic Department.

a. Contractor shall install:

- Post
- Base, including sonotube and PVC conduit
- Equipment housing, if required
- Conduit Runs
- Concrete
- Prepare the surface for installation of the induction loops and trench for conduit runs
- Induction loops
- Infrared sensor
- Communications
- Logger
- Induction loop sensor
- Battery pack

b. Traffic Department shall test:

- Induction loops
- Infrared sensor
- Communications
- Logger
- Induction loop sensor
- Battery pack

2. Post

a. Install per the manufacturer's recommendations.

3. Equipment Housing, if required

a. Install per the manufacturer's recommendations.

b. Prior to installation, verify groundwater level. If groundwater is encountered within the excavation limits, contact the Engineer.

- c. The entire bottom of the equipment housing shall be bedded in coarse aggregate material to a minimum depth of 18 inches.
- 4. Infrared Sensors
 - a. Install per the manufacturer's recommendations.
 - b. Infrared sensor(s) must operate in tandem with the induction loops.
- 5. Induction Loops
 - a. Location shown on the Contract Drawings is estimated; prior to installation, the Contractor shall meet with the Traffic Department to determine actual locations. The induction loops shall be located within one five-foot (5') panel. The Contractor shall mark the actual location.
 - b. Contractor shall prepare the surface in accordance with Section 30.03 – Portland Cement Concrete Sidewalks or Section 40.06 Asphalt Concrete Pavement. The area identified for placement of the induction loops shall be graded flat and relatively free of debris.
 - c. Contractor shall create trench to hold encased induction loop tail.
 - d. Contractor shall install induction loops on the prepared surface and the Traffic Department shall test the induction loops.
 - e. Surface Treatment Installation
 - i. Concrete Sidewalk Installation -Contractor shall carefully spread concrete over the induction loops and finish the concrete in accordance with Section 30.03 – Portland Cement Concrete Sidewalks. Contractor shall replace any damaged components at Contractors expense.
 - ii. Asphalt Pathway Installation -Contractor shall carefully spread and compact asphalt concrete over the induction loops in accordance with Section 40.06 – Asphalt Concrete Pavement. Contractor shall replace any damaged components at Contractors expense.
 - f. After installation, the Traffic Department shall perform a final induction loop test, ensuring read is between 100 to 150 microhenries (μH). Coordinate test with the Traffic Department.
- 6. Encased induction loop tail shall be run from the induction loops to the post or equipment housing, if required. Contractor shall install the loop tail runs. The Traffic Department shall test the runs to ensure they operate as expected.
- 7. Electrical termination shall be installed by the Contractor and tested by the Traffic Department.
- 8. The Traffic Department shall test all communications of the Multi-Modal Counter.

Article 12.4 Measurement

Measurement of Multi-Modal Counter shall be per each, complete and in place, including all coordination, labor, equipment, specified materials, and miscellaneous materials to provide a complete unit accepted by the Traffic Department.

Article 12.5 Payment

Payment for this Work shall be in accordance with Division 10, Section 10.07 – Measurement and Payment and shall include full payment for all Work described in this Section.

Payment shall be made on the following unit:

ITEM	UNIT
Multi-Modal Pathway Counter	Each
Multi-Modal Sidewalk Counter	Each

**MUNICIPALITY OF ANCHORAGE
STANDARD SPECIFICATIONS**

**DIVISION 85
TRAFFIC CONTROL DEVICES
STANDARD DETAILS**

**STANDARD CONSTRUCTION SPECIFICATIONS
DIVISION 85
INDEX OF STANDARD DETAILS**

85-1	Striping Notes
85-2	Intersection Approach Striping
85-3	Left-Turn Pocket Approach Striping
85-4	Raised Median Approach and Two Lanes Drive to Right Striping
85-5	Left-Turn Pocket Approach from Two Way Center Left-Turn Lane Striping
85-6	Two Way Center Left Turn Lane Striping
85-7	Passing on Both Sides of a Right Hand Side Obstruction
85-8A	Layout Templates for Stencils Part 1
85-8B	Layout Templates for Stencils Part 2
85-9	Gap Ladder Crosswalk Striping
85-10	Skewed Gap Ladder Crosswalk Striping
85-11	Approach to Railroad Crossing on 2 Lane 2 Way Highway
85-12	Typical Uncurbed Return with Pathway
85-13	Typical Uncurbed Return without Pathway
85-14	Typical Curb Return with Sidewalk
85-15	Typical Curb Return without Sidewalk
85-16	Compact Roundabout Arrow Markings
85-17	Post Mounted Sign with Shoulder
85-18	Post Mounted Sign with No Shoulder
85-19	Post Mounted Sign with Guardrail
85-20	Post Mounted Sign Curb without Sidewalk
85-21	Post Mounted Sign Curb with Parkway and Sidewalk
85-22	Post Mounted Sign Curb with Sidewalk without Parkway
85-23	Post Mounted Sign Raised Medians
85-24	Post Mounted Sign Secondary Panel Height and Sign Positioning
85-25	Street Name Signs
85-26	Sign on Round Post
85-27	Street Name on Round Post
85-28	Concrete Foundation for Sign Post
85-29	12" Plate Installation Detail with Supplemental 8" D3-101 Signs
85-30	Signal Pole Mast Arm Sign Mounting

85-31	Clearing for Signs
85-32	Guardrail Detail
85-33	Cluster Mailbox Location
85-34	Mailbox Location
85-35	Flexible Delineator
85-36	Sinusoidal Speed Hump
85-37	Asphalt Flat Top Speed Hump
85-38	Asphalt Speed Cushion
85-39	Asphalt Speed Cushion Striping
85-40	Type A Raised Crosswalk
85-41	Raised Crosswalk Striping and Notes
85-42	Multi-Modal Pathway Counter
85-43	Multi-Modal Sidewalk Counter

GENERAL NOTES:

1. ALL ONLYS, ARROWS, CROSSWALKS, STOP BARS AND OTHER MARKINGS SHALL BE AS INDICATED IN THE DRAWINGS AND SPECIFICATIONS.
2. DUAL-TURN LANE, TURN POCKET REVERSAL AND CENTERLINE DOUBLE LINES SHALL BE TWO 4" YELLOW LINES SEPARATED BY A 4" SPACE.
3. REGULAR LANE LINES SHALL BE A WHITE 4" WIDE LINE. SKIP LINE SPACING SHALL BE A 10' LINE AND A 30' SPACE.
4. MEDIAN NOSE AND THE TOP AND FACE OF CURB OF ALL MEDIAN ISLAND NOSING SHALL BE YELLOW A MINIMUM OF 5' BACK FROM THE FLOWLINE.
5. "W" IS THE WIDTH OF THE LANE MEASURED FROM CENTER LANE LINE TO CENTER LANE LINE OR FROM CENTER LANE LINE TO EDGE OF PAVEMENT.
6. "L" IS TAPER LENGTH. "L" IS DETERMINED BY TAKING THE SPEED LIMIT (M.P.H.) TIMES THE OFFSET WIDTH IN FEET OR AS INDICATED ON DRAWINGS. MINIMUM "L" IS 100'.
7. "D" IS THE LANE REVERSAL DISTANCE. A RATIO OF 8:1 FOR THE ENTRANCE TAPER IS DESIRABLE WITH A MINIMUM RATIO OF 3:1.
8. "S" IS THE SHY DISTANCE MEASURED FROM THE FACE OF CURB TO THE CENTER OF THE OUTSIDE YELLOW LINE. "S" IS 18" OR AS SHOWN ON THE DRAWINGS.
9. THESE NOTES APPLY TO STANDARD DETAILS 85-2 THROUGH 85-11.

REVISION: 2024 M.A.S.S. UPDATE

MUNICIPALITY



OF ANCHORAGE

SCALE:
N.T.S.

APPROVED:

REVISED:
2/24

STRIPING NOTES

SECTION #
85.03

DETAIL #
85-1

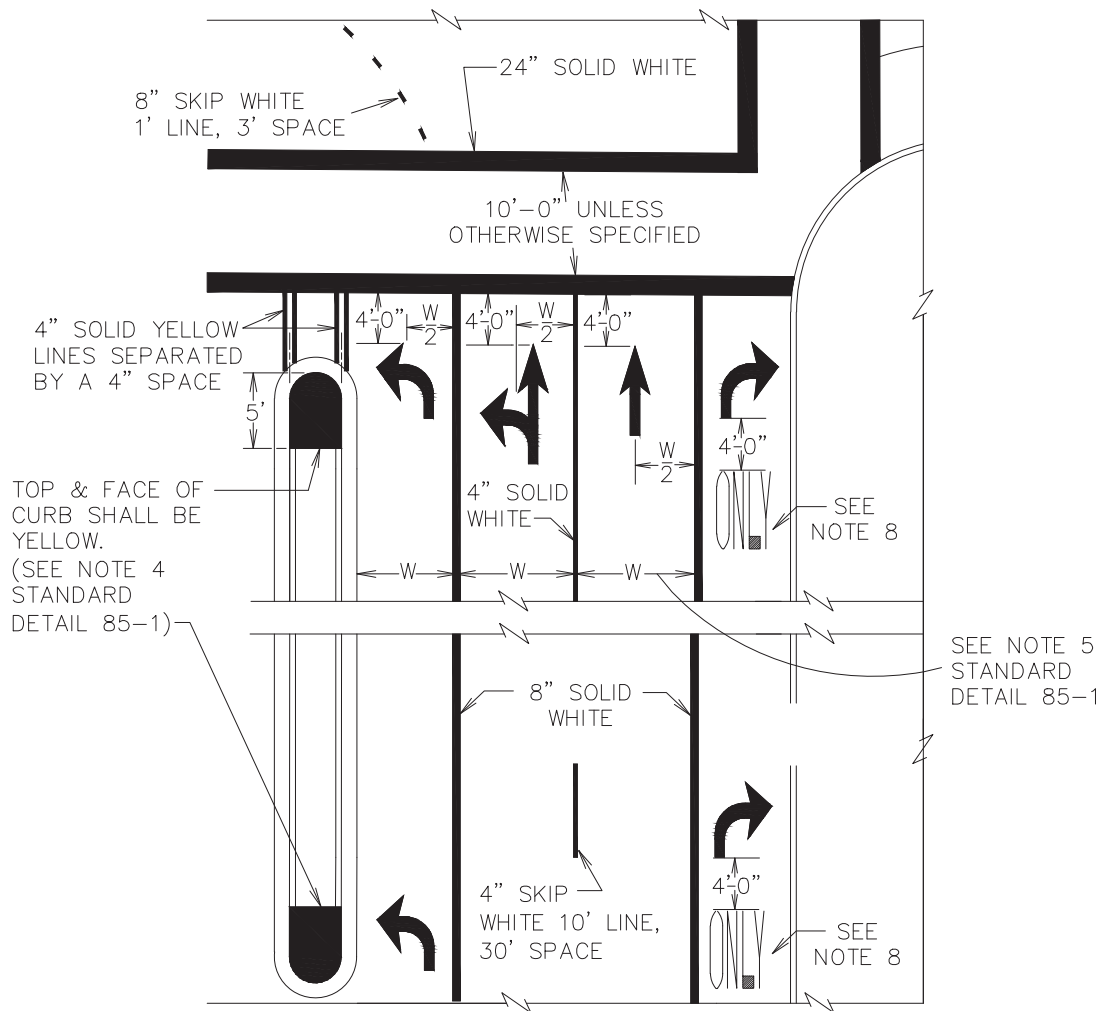

APPROACH TO INTERSECTION

1. ARROW MARKINGS SHALL BE PLACED AT THE START OF AND AT THE INTERSECTION OF AUXILIARY TURN LANES. ADDITIONAL ARROW MARKINGS SHALL BE PLACED AND SPACED PROPORTIONATELY WHEN AUXILIARY TURN LANES EXCEED 150'.
2. REGULAR LANE LINES SHALL BE A SOLID WHITE 4" LINE.
3. LEFT AND RIGHT TURN DELINEATOR LINES SHALL BE A SOLID WHITE 8" LINE.
4. 4" SOLID WHITE LINES APPROACHING INTERSECTIONS ARE 100' IN LENGTH MINIMUM.
5. 4" SOLID WHITE LINES DEPARTING INTERSECTIONS ARE 50' IN LENGTH PLUS THE PARTIAL SKIP CYCLE LENGTH.
6. DOTTED GUIDELINES USED FOR DUAL TURN LANES SHALL BE 8" WHITE SKIP WITH A 1' LINE AND A 3' SPACE.
7. STRAIGHT AHEAD AND COMBINATION ARROWS SHALL BE USED ONLY WHEN INDICATED ON DRAWINGS.
8. "ONLY" WORD MARKINGS ARE USED ONLY WHEN A THROUGH LANE TERMINATES AS A TURN.

REVISION: 2024 M.A.S.S. UPDATE

MUNICIPALITY



OF ANCHORAGE

SCALE:
N.T.S.

APPROVED:

REVISED:
2/24

INTERSECTION APPROACH STRIPING

SECTION #
85.03

DETAIL #
85-2

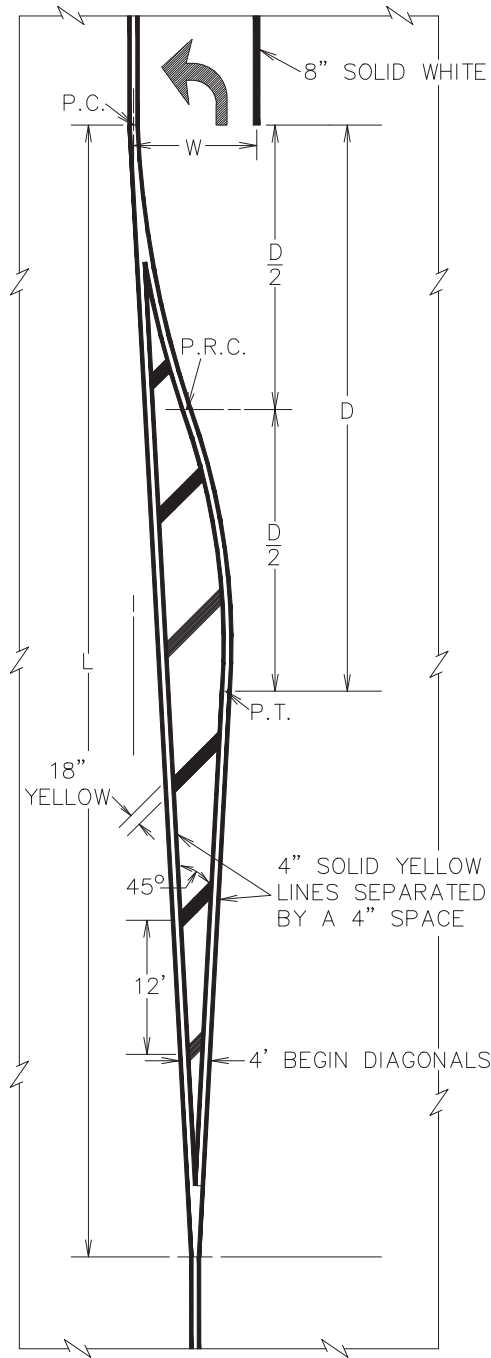

LEFT-TURN POCKET APPROACH

SEE STANDARD DETAIL 85-1 FOR GENERAL STRIPING NOTES

REVISION: 2024 M.A.S.S. UPDATE

MUNICIPALITY



OF ANCHORAGE

SCALE:
N.T.S.

APPROVED:

REVISED:
2/24

LEFT-TURN POCKET APPROACH STRIPING

SECTION #
85.03

DETAIL #
85-3

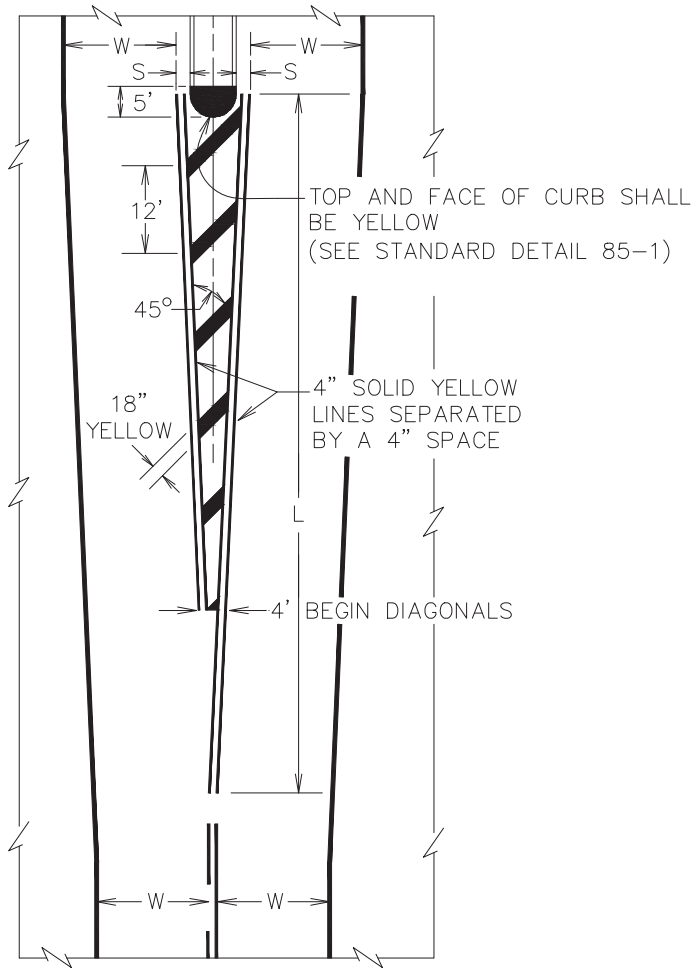

RAISED MEDIAN APPROACH

SEE STANDARD DETAIL 85-1 FOR GENERAL STRIPING NOTES

REVISION: 2024 M.A.S.S. UPDATE

MUNICIPALITY



OF ANCHORAGE

SCALE:
N.T.S.

APPROVED:

REVISED:
2/24

RAISED MEDIAN APPROACH AND TWO LANES DRIVE TO RIGHT STRIPING

SECTION #
85.03

DETAIL #
85-4

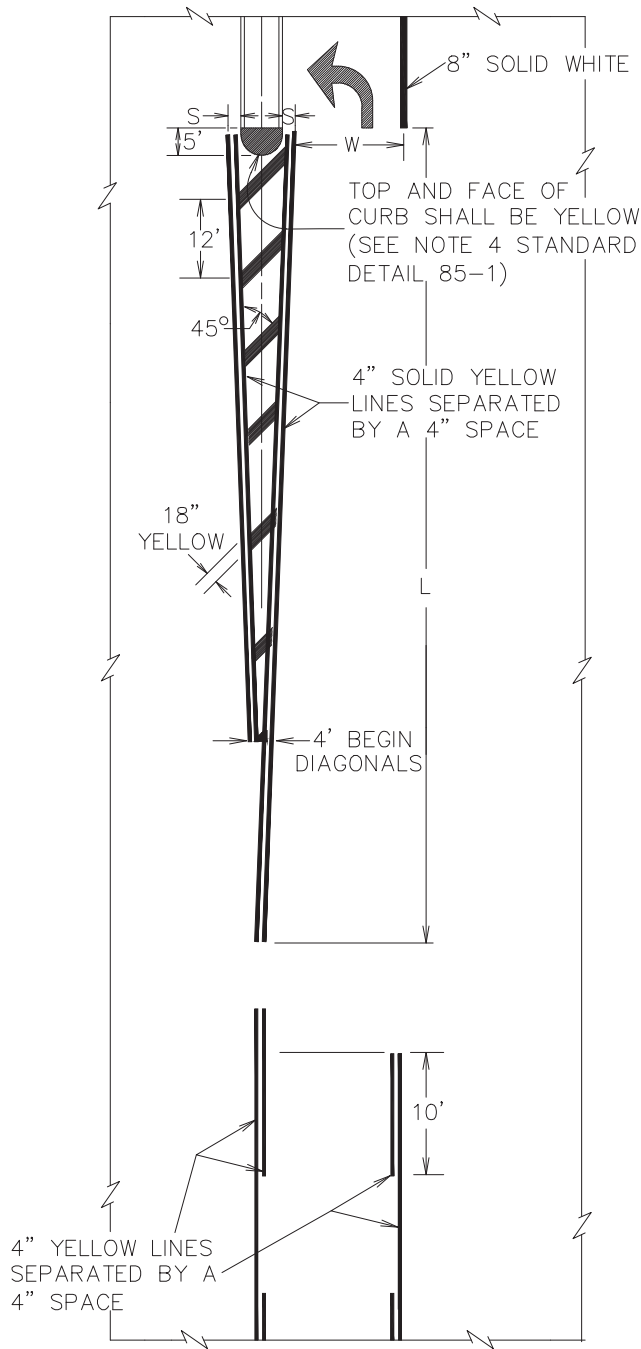

LEFT-TURN POCKET APPROACH FROM TWO WAY CENTER LEFT-TURN LANE

SEE STANDARD DETAIL 85-1 FOR GENERAL STRIPING NOTES

REVISION: 2024 M.A.S.S. UPDATE

MUNICIPALITY



OF ANCHORAGE

SCALE:
N.T.S.

APPROVED:

REVISED:
2/24

**LEFT-TURN POCKET APPROACH
FROM TWO WAY CENTER
LEFT-TURN LANE STRIPING**

SECTION #
85.03

DETAIL #
85-5

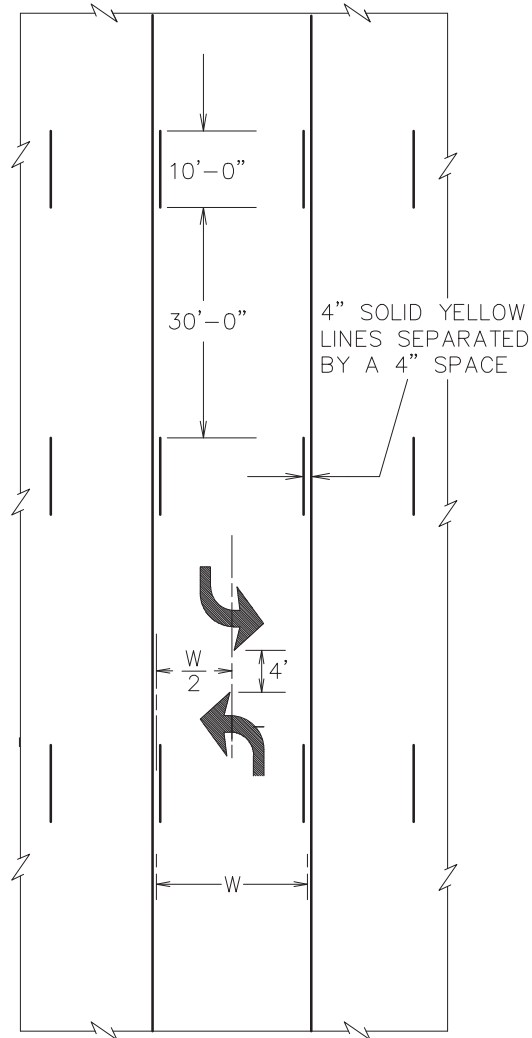

TWO WAY CENTER LEFT TURN LANE

1. INSTALL DUAL TURN LANE ARROWS EVERY 200', UNLESS OTHERWISE SPECIFIED.



TWO WAY CENTER LEFT TURN LANE STRIPING

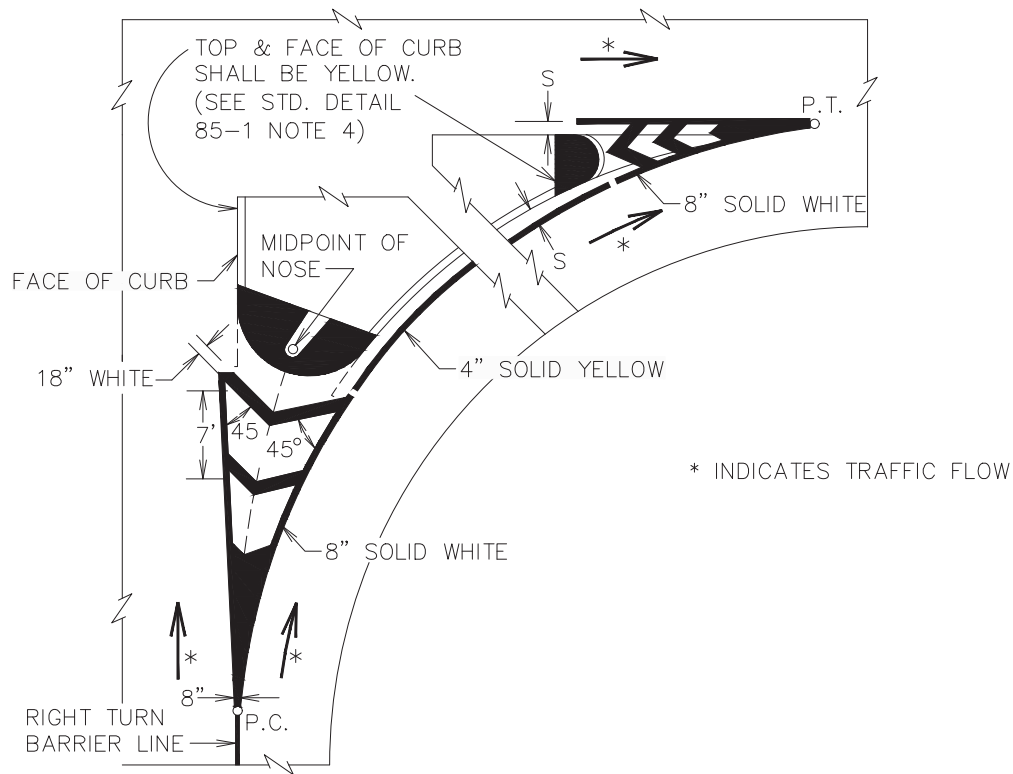

**PASSING ON BOTH SIDES OF A
RIGHT HAND SIDE OBSTRUCTION**

SEE STANDARD DETAIL 85-1 FOR GENERAL STRIPING NOTES

REVISION: 2024 M.A.S.S. UPDATE

MUNICIPALITY

 OF ANCHORAGE

SCALE:
N.T.S.
 APPROVED:
 REVISED:
2/24

**PASSING ON BOTH SIDES OF
A RIGHT HAND SIDE
OBSTRUCTION**

SECTION #
85.03
 DETAIL #
85-7

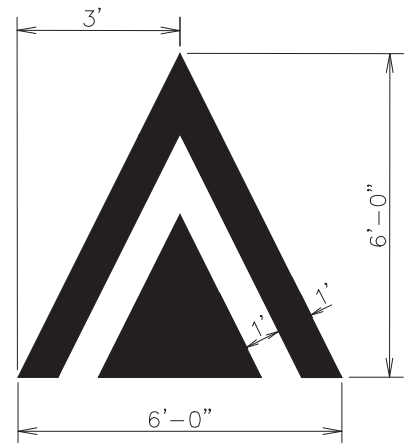
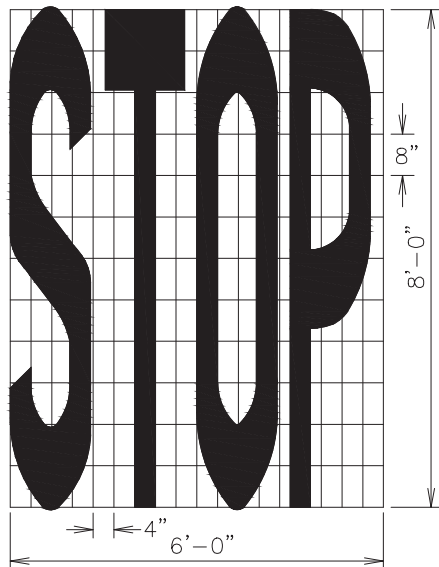
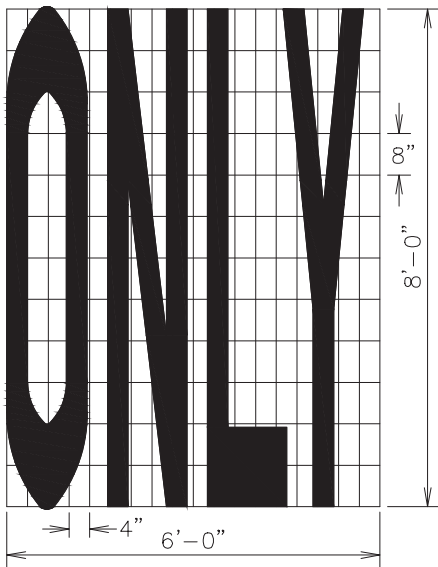
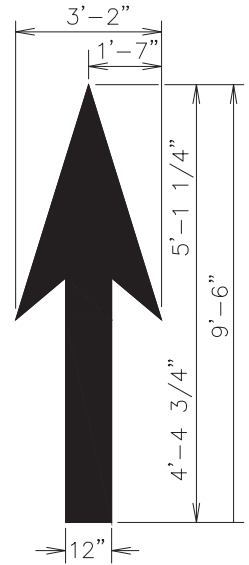
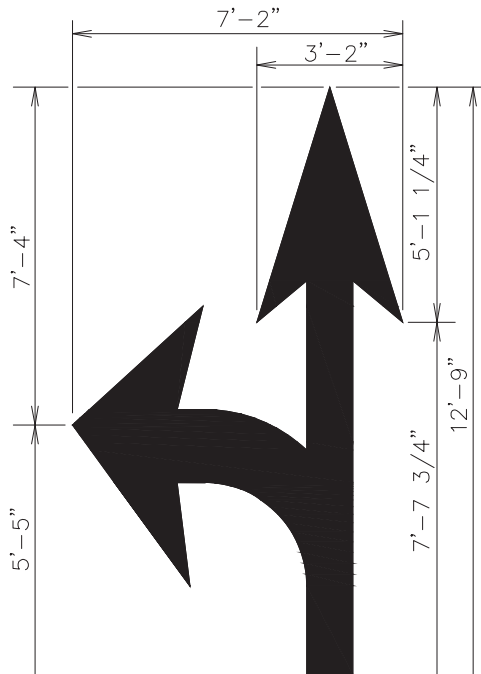
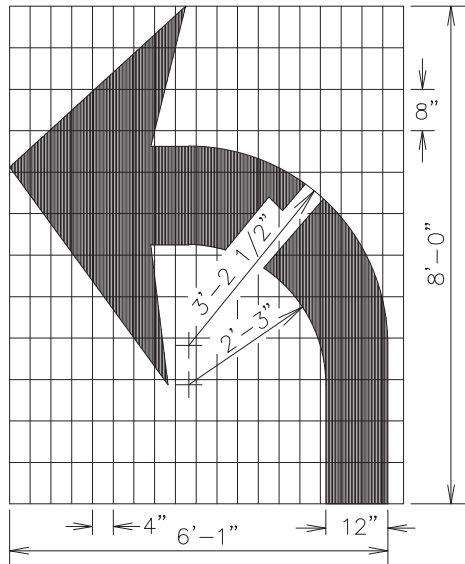

LAYOUT TEMPLATES FOR STENCILS

1. ALL SYMBOLS SHOWN SHALL BE WHITE AND REFLECTORIZED.
2. RIGHT AND LEFT TURN AUXILIARY LANE MARKINGS ARE IDENTICAL BUT REVERSED.

REVISION: 2024 M.A.S.S. UPDATE

MUNICIPALITY

 OF ANCHORAGE

SCALE:
N.T.S.
 APPROVED:
 REVISED:
2/24

LAYOUT TEMPLATES FOR STENCILS PART 1

SECTION #
85.03
 DETAIL #
85-8A

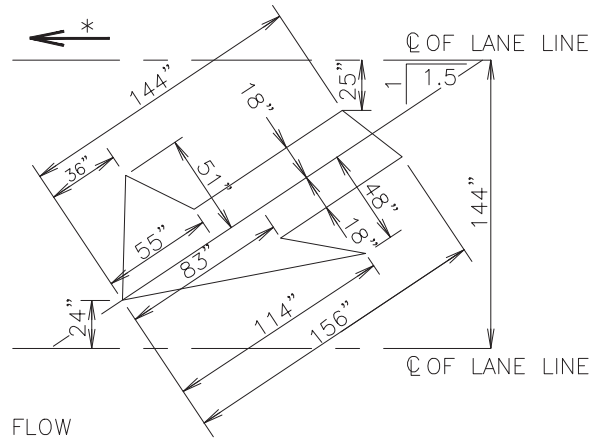
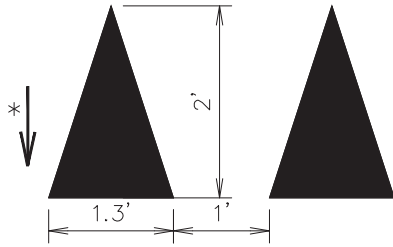

* INDICATES TRAFFIC FLOW

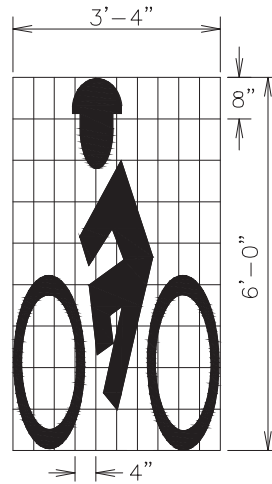
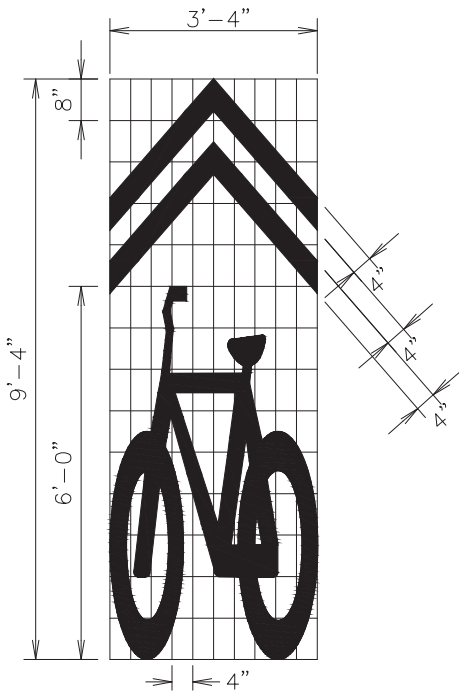

LAYOUT TEMPLATES FOR STENCILS

1. ALL SYMBOLS SHOWN SHALL BE WHITE AND REFLECTORIZED.
2. RIGHT AND LEFT TURN AUXILIARY LANE MARKINGS ARE IDENTICAL BUT REVERSED.

REVISION: 2024 M.A.S.S. UPDATE



SCALE:
N.T.S.
APPROVED:
REVISED:
2/24

LAYOUT TEMPLATES FOR STENCILS PART 2

SECTION #
85.03

DETAIL #
85-8B

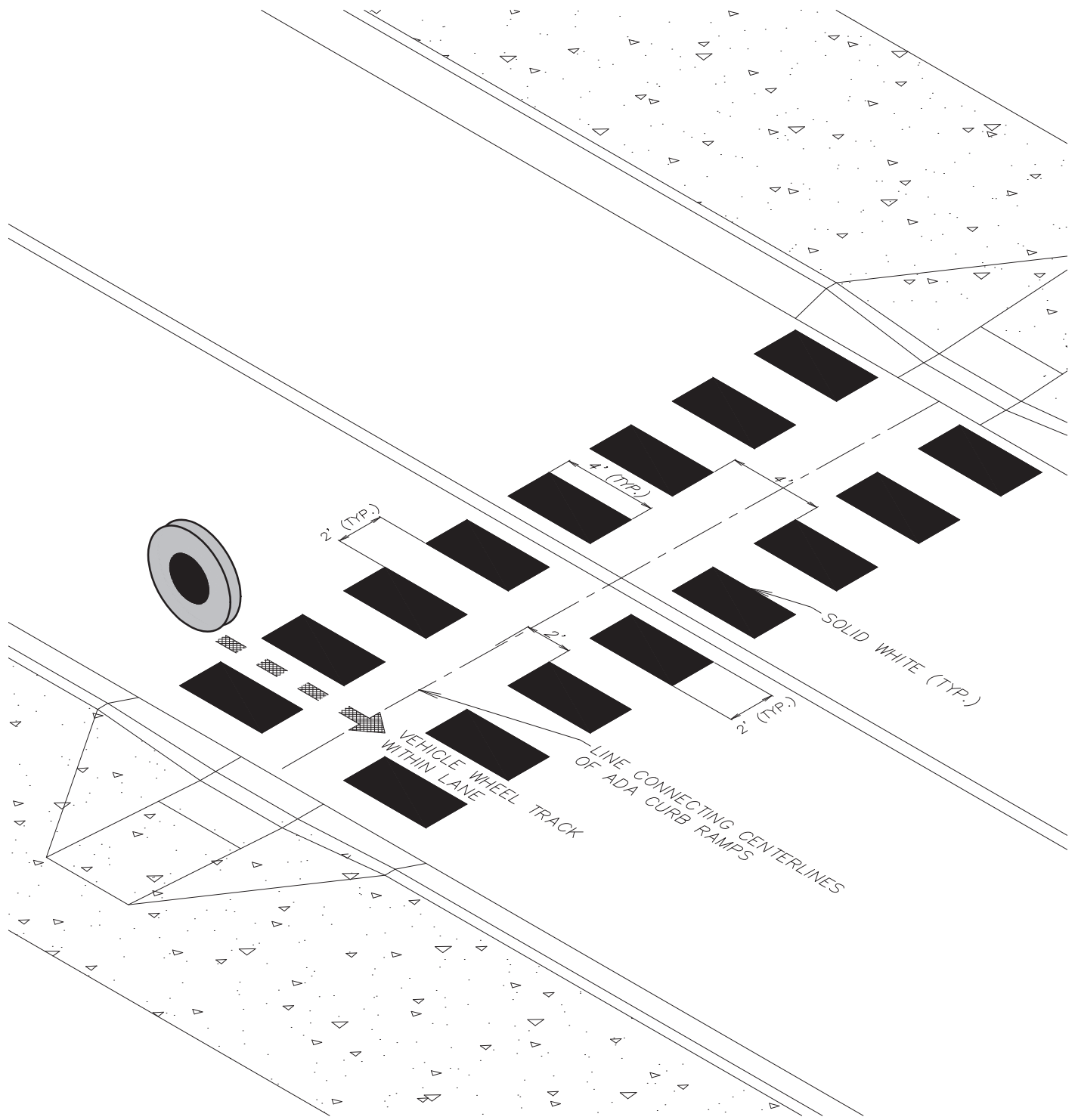

GAP LADDER CROSSWALK STRIPING

NOTES:

1. SEE DETAIL 85-10 FOR SKEWED LAYOUT

REVISION: 2024 M.A.S.S. UPDATE

 MUNICIPALITY OF ANCHORAGE	SCALE: N.T.S. APPROVED: REVISED: 2/24	<h1 style="margin: 0;">GAP LADDER CROSSWALK STRIPING</h1>	SECTION # 85.03 DETAIL # 85-9
---	---	---	--

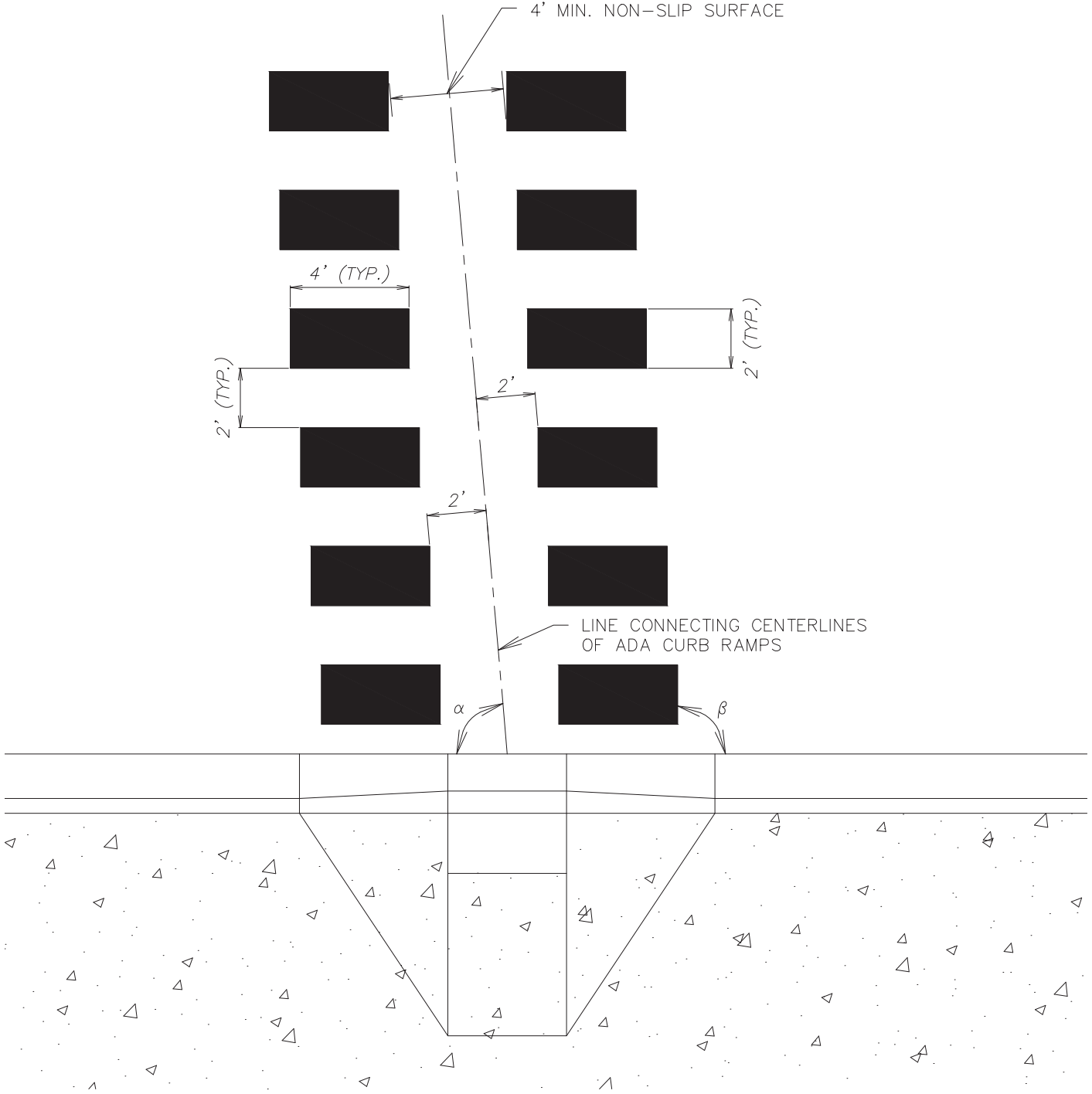

SKewed GAP LADDER CROSSWALK STRIPING

NOTES:

1. $75^\circ < \alpha < 90^\circ$
2. $\beta = 90^\circ$ RELATIVE TO LINE CONNECTING CURB AND GUTTER

REVISION: 2024 M.A.S.S. UPDATE

MUNICIPALITY

 OF ANCHORAGE

SCALE:
N.T.S.
 APPROVED:
 REVISED:
2/24

**SKewed GAP LADDER
 CROSSWALK STRIPING**

SECTION #
85.03
 DETAIL #
85-10



SCALE:
N.T.S.
APPROVED:
REVISED:
2/24

APPROACH TO RAILROAD CROSSING ON 2 LANE 2 WAY HIGHWAY

SECTION #
85.03
DETAIL #
85-11

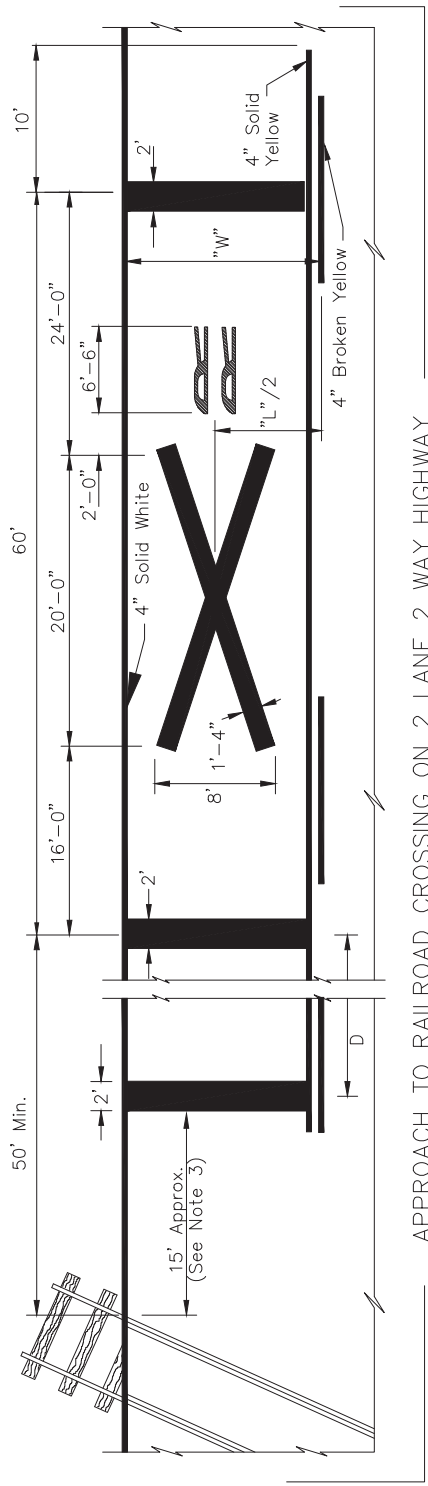

- NOTES:
- ALL MARKINGS SOLID WHITE UNLESS INDICATED OTHERWISE.
 - ON 4-LANE ROADWAYS THE RAILROAD CROSSING APPROACH MARKING SHALL BE PLACED IN EACH LANE OF THE APPROACH.
 - LOCATE STOP BAR 15' FROM RAILROAD TRACK OR 8' FROM GATE, IF PRESENT.
 - EDGE LINES AND LANE LINES ON A UNI-DIRECTIONAL APPROACH SHALL BE PLACED IN A NORMAL MANNER EXCEPT THAT THE LANE LINE(S) SHALL BE SOLID 4" WHITE IN LIEU OF BROKEN FOR A DISTANCE = (D+60') IN ADVANCE OF THE STOP BANDS.

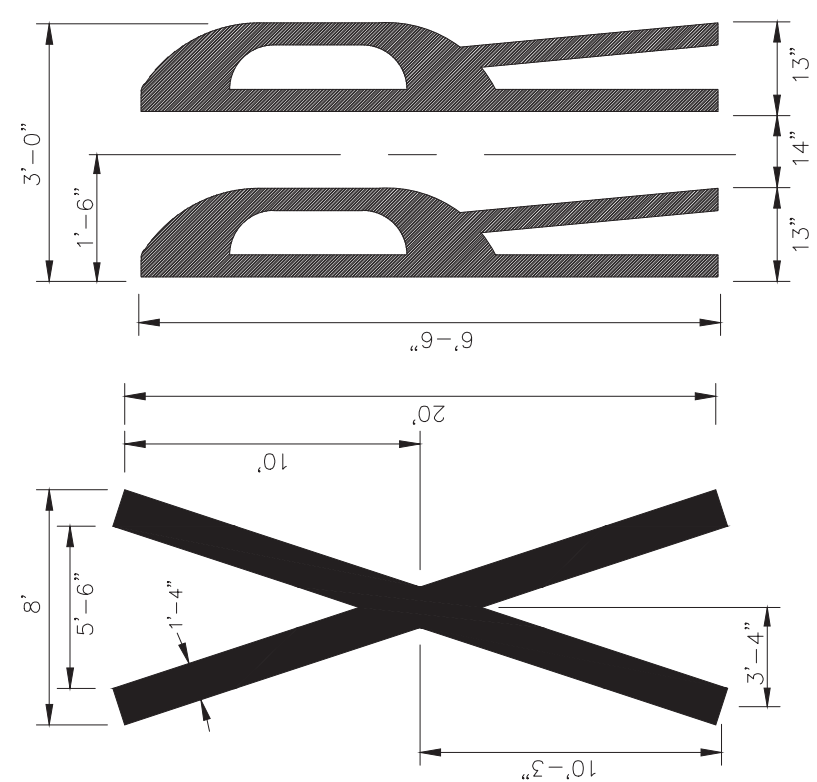

RAILROAD CROSSING SYMBOLS

POSTED LIMIT	D
30 M.P.H.	225'
40	350'
50	475'
60	625'

MUNICIPALITY



OF ANCHORAGE

SCALE:
N.T.S.

APPROVED:

REVISED:
2/24

TYPICAL UNCURBED RETURN WITH PATHWAY

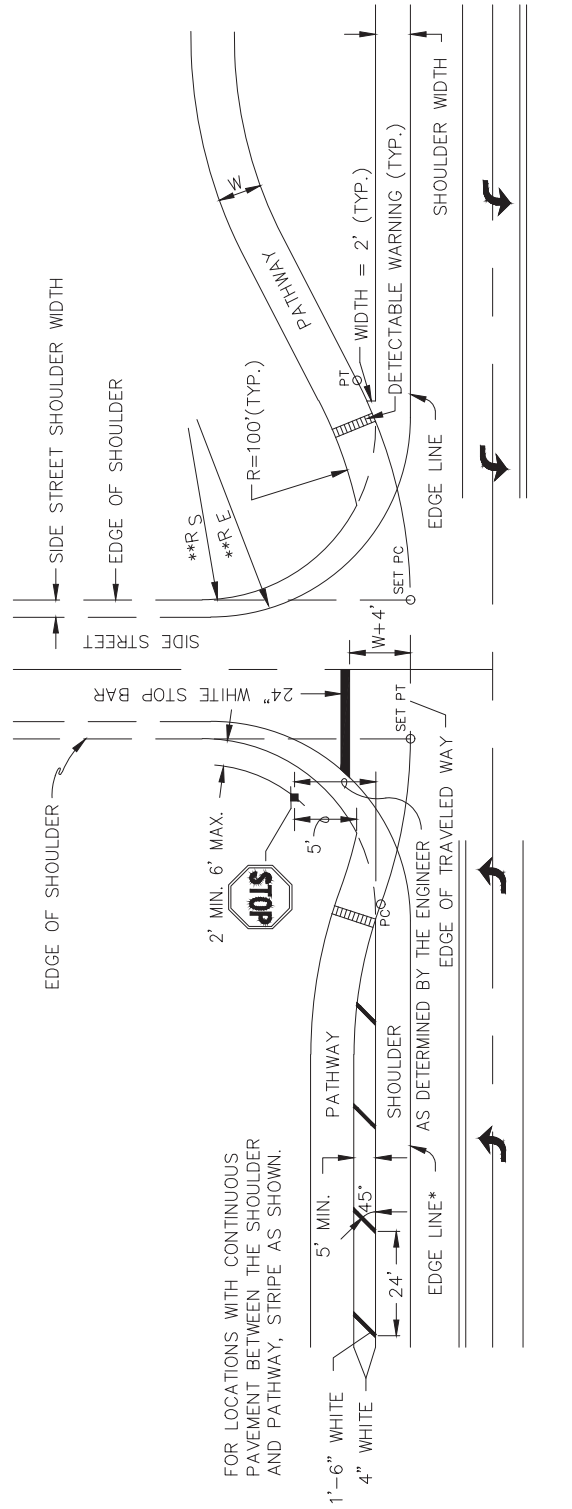

* EDGE LINES DEFINE THE EDGE OF TRAVELED WAY

**R S = SHOULDER RADIUS

**R E = EDGE LINE RADIUS

TYPICAL UNCURBED RETURN WITH PATHWAY

1. WHEN THE SIDE STREET LACKS EDGE LINES, BEGIN AND END THE MAIN STREET EDGE LINES AT THE MAIN STREET PAVEMENT RETURNS AND EXTEND THE STOP BAR TO THE EDGE OF PAVEMENT AS SHOWN IN THE *UNCURBED RETURN WITHOUT PATHWAY* DETAIL.
2. INSTALL DETECTABLE WARNING TILES IN PATHWAYS AT THE LOCATIONS SHOWN. INSTALL ACCORDING TO THE MANUFACTURER'S WRITTEN INSTALLATION INSTRUCTIONS.
3. BREAK THE MAIN STREET CENTERLINE MARKINGS AT SIDE STREET INTERSECTIONS ONLY WHEN LEFT TURN LANES ARE PROVIDED.
4. CONTINUE CENTERLINE STRIPING THROUGH INTERSECTIONS WITH CENTER TWO-WAY-LEFT-TURN-ONLY LANES OR WHEN THERE ARE NO MAINLINE LEFT TURN LANES.
5. LOCATE STOP SIGNS SO THEY ARE:
 - A. VISIBLE TO APPROACHING TRAFFIC AND
 - B. AS NEAR TO THE STOP BAR AS PRACTICABLE.
6. CONTINUE LANE "SKIP" STRIPING THROUGH INTERSECTIONS.
7. DELETE OUTERMOST EDGE OF TRAVELED WAY STRIPING AT INTERSECTIONS OR WRAP STRIPING TO SIDE STREET.
8. MATCH SIDE STREET STRIPING IF STRIPING IS PRESENT.

SECTION #
85.03

DETAIL #
85-12

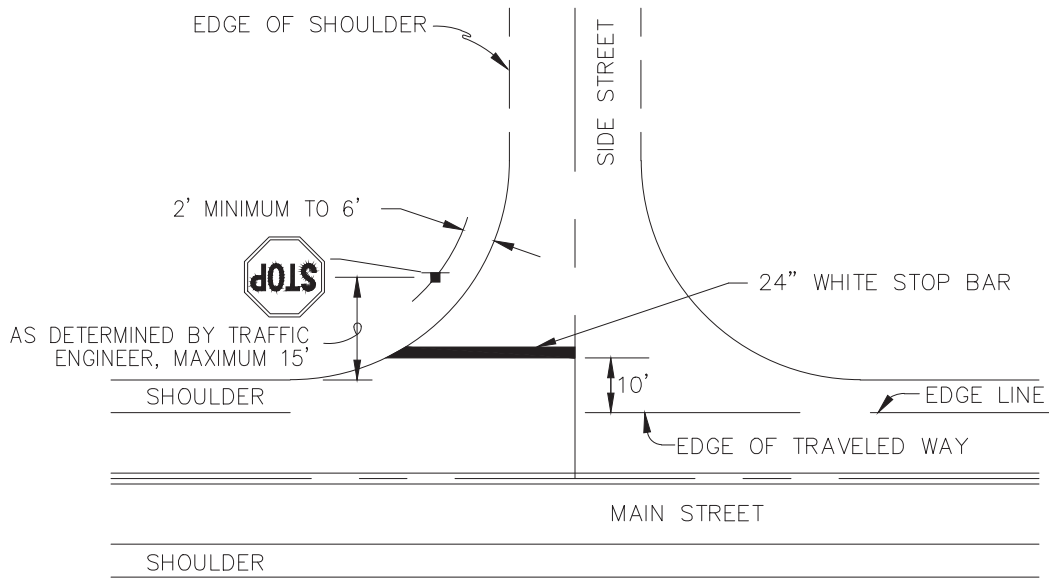

TYPICAL UNCURBED RETURN WITHOUT PATHWAY

NOTES:

1. BREAK THE MAIN STREET CENTERLINE MARKINGS AT SIDE STREET INTERSECTIONS ONLY WHEN LEFT TURN LANES ARE PROVIDED.
2. CONTINUE CENTERLINE STRIPING THROUGH INTERSECTIONS WITH CENTER TWO-WAY-LEFT-TURN-ONLY LANES OR WHEN THERE ARE NO MAINLINE LEFT TURN LANES.
3. LOCATE STOP SIGNS SO THEY ARE:
 - A. VISIBLE TO APPROACHING TRAFFIC AND
 - B. AS NEAR TO THE STOP BAR AS PRACTICABLE.
4. CONTINUE LANE "SKIP" STRIPING THROUGH INTERSECTIONS.
5. DELETE OUTERMOST EDGE OF TRAVELED WAY STRIPING AT INTERSECTIONS OR WRAP STRIPING TO SIDE STREET.
6. MATCH SIDE STREET STRIPING IF STRIPING IS PRESENT.

REVISION: 2024 M.A.S.S. UPDATE

MUNICIPALITY



OF ANCHORAGE

SCALE:
N.T.S.

APPROVED:

REVISED:
2/24

TYPICAL UNCURBED RETURN WITHOUT PATHWAY

SECTION #
85.03

DETAIL #
85-13

MUNICIPALITY



OF ANCHORAGE

SCALE:
N.T.S.

APPROVED:

REVISED:
2/24

TYPICAL CURB RETURN WITH SIDEWALK

SECTION #
85.03

DETAIL #
85-14

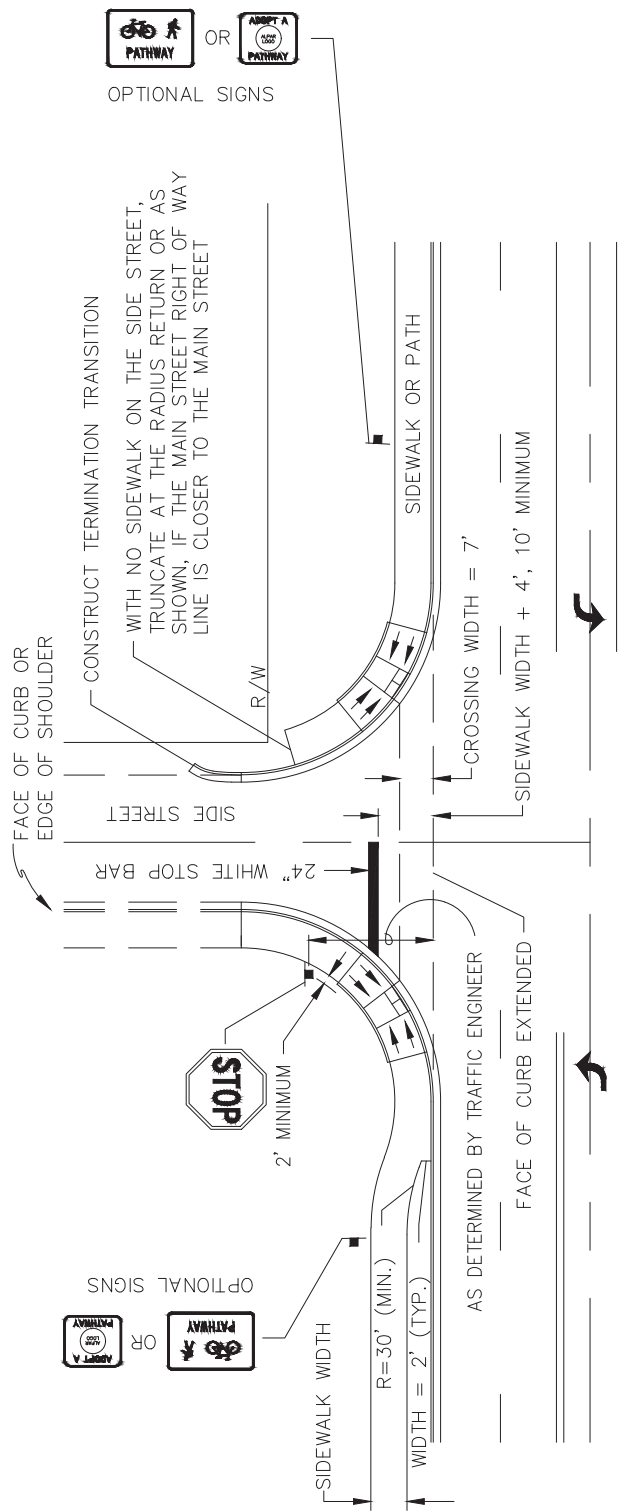

TYPICAL CURBED RETURN WITH SIDEWALK

NOTES:

1. WHEN SIDEWALKS ARE SEPARATED FROM THE BACK OF CURB, JOIN THE TWO AS SHOWN USING A REVERSE CURVE WITH A MINIMUM RADIUS OF 30'.
2. BREAK THE MAIN STREET CENTERLINE MARKINGS AT SIDE STREET INTERSECTIONS ONLY WHEN LEFT TURN LANES ARE PROVIDED.
3. CONTINUE CENTERLINE STRIPING THROUGH INTERSECTIONS WITH CENTER TWO-WAY-LEFT-TURN-ONLY LANES OR WHEN THERE ARE NO MAINLINE LEFT TURN LANES.
4. CONTINUE LANE "SKIP" STRIPING THROUGH INTERSECTIONS.
5. DELETE OUTERMOST EDGE OF TRAVELED WAY STRIPING AT INTERSECTIONS OR WRAP STRIPING TO SIDE STREET.
6. MATCH SIDE STREET STRIPING IF STRIPING IS PRESENT.

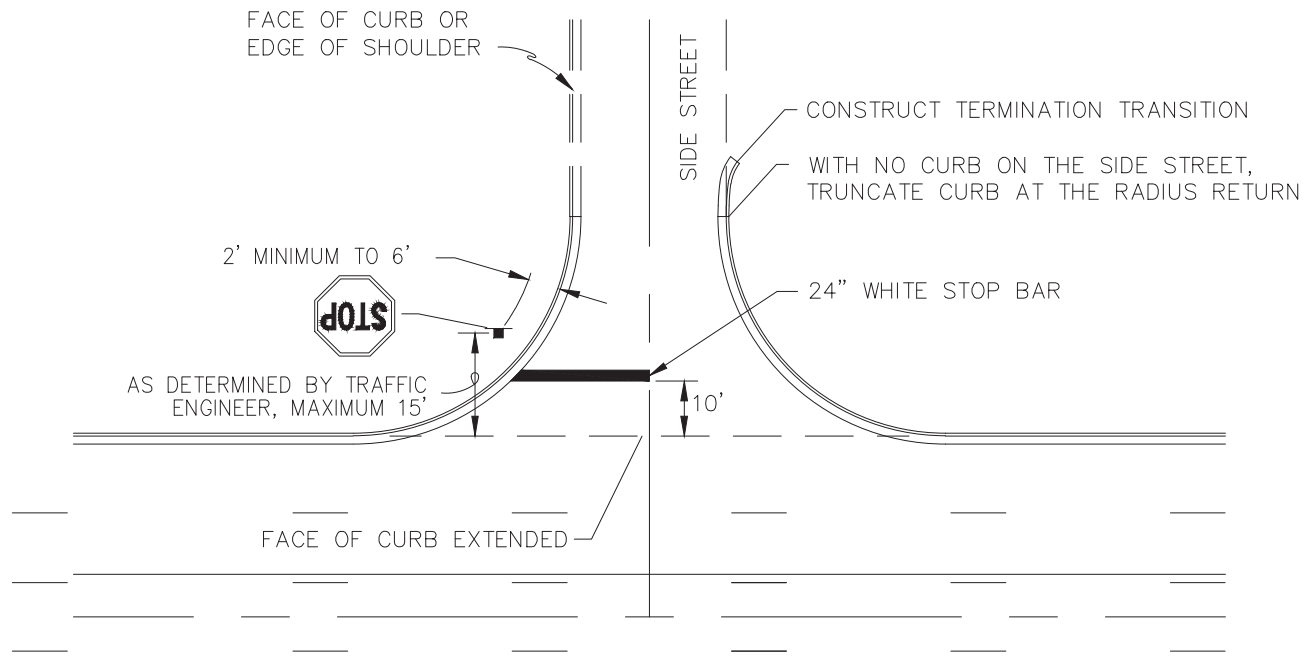

TYPICAL CURBED RETURN WITHOUT SIDEWALK

NOTES:

1. BREAK THE MAIN STREET CENTERLINE MARKINGS AT SIDE STREET INTERSECTIONS ONLY WHEN LEFT TURN LANES ARE PROVIDED.
2. CONTINUE CENTERLINE STRIPING THROUGH INTERSECTIONS WITH CENTER TWO-WAY-LEFT-TURN-ONLY LANES OR WHEN THERE ARE NO MAINLINE LEFT TURN LANES.
3. LOCATE STOP SIGNS SO THEY ARE:
 - A. VISIBLE TO APPROACHING TRAFFIC
 - B. AS NEAR TO THE STOP BAR AS PRACTICABLE.
4. CONTINUE LANE "SKIP" STRIPING THROUGH INTERSECTIONS.
5. DELETE OUTERMOST EDGE OF TRAVELED WAY STRIPING AT INTERSECTIONS OR WRAP STRIPING TO SIDE STREET.
6. MATCH SIDE STREET STRIPING IF STRIPING IS PRESENT.

REVISION: 2024 M.A.S.S. UPDATE

 MUNICIPALITY OF ANCHORAGE	SCALE: N.T.S. APPROVED: REVISED: 2/24	<h1 style="margin: 0;">TYPICAL CURB RETURN WITHOUT SIDEWALK</h1>	SECTION # 85.03 DETAIL # 85-15
---	---	--	---

PENDING

REVISION: 2024 M.A.S.S. UPDATE

MUNICIPALITY



OF ANCHORAGE

SCALE:
N.T.S.

APPROVED:

REVISED:
2/24

**COMPACT ROUNDABOUT
ARROW MARKINGS**

SECTION #
85.03

DETAIL #
85-16

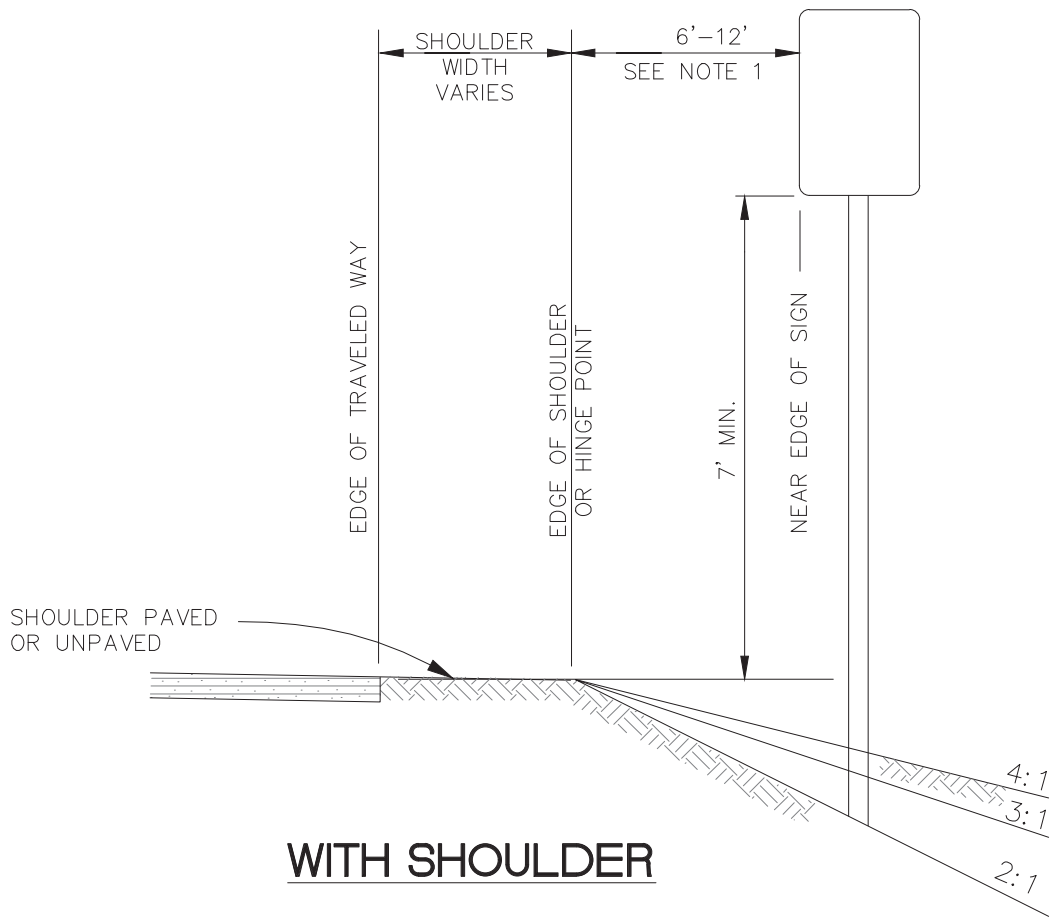

NOTES:

1. UNLESS SHOWN OTHERWISE ON THE DRAWINGS, THE STANDARD SIGN OFFSET IS 12'. THE MINIMUM IS 6'.
2. IF SIGNS EXTEND OVER SIDEWALKS, THE MINIMUM VERTICAL CLEARANCE IS 7'-0".
3. ADD 6" TO MOUNTING HEIGHT ON UNPAVED ROADS.
4. IF SIGNS EXTEND OVER BIKE PATHS, THE MINIMUM VERTICAL CLEARANCE IS 8'-0".
5. PAINT ALL SIGN MOUNTING FASTENERS ON SIGN FACE A COLOR MATCHING THE SIGN FACE.
6. ATTACH ALL SIGN FRAMING AND BRACES MOUNTED TO THE POSTS WITH 5/16" BOLTS WITH SELF-LOCKING NUTS.

REVISION: 2024 M.A.S.S. UPDATE

MUNICIPALITY



OF ANCHORAGE

SCALE:
N.T.S.

APPROVED:

REVISED:
2/24

**POST MOUNTED SIGN
WITH SHOULDER**

SECTION #
85.04

DETAIL #
85-17

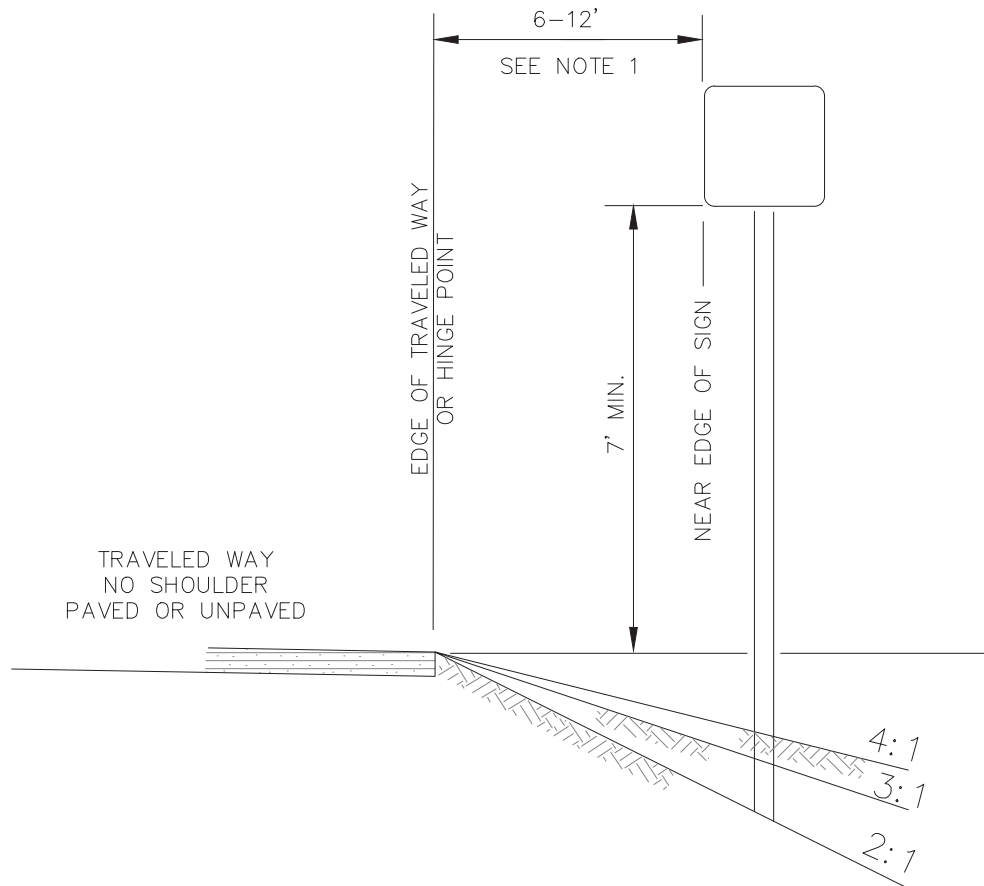

NO SHOULDER

NOTES:

1. UNLESS SHOWN OTHERWISE ON THE DRAWINGS, THE STANDARD SIGN OFFSET IS 12'. THE MINIMUM IS 6'.
2. IF SIGNS EXTEND OVER SIDEWALKS, THE MINIMUM VERTICAL CLEARANCE IS 7'-0".
3. ADD 6" TO MOUNTING HEIGHT ON UNPAVED ROADS.
4. IF SIGNS EXTEND OVER BIKE PATHS, THE MINIMUM VERTICAL CLEARANCE IS 8'-0".
5. PAINT ALL SIGN MOUNTING FASTENERS ON SIGN FACE A COLOR MATCHING THE SIGN FACE.
6. ATTACH ALL SIGN FRAMING AND BRACES MOUNTED TO THE POSTS WITH 5/16" BOLTS WITH SELF-LOCKING NUTS.

REVISION: 2024 M.A.S.S. UPDATE

MUNICIPALITY



OF ANCHORAGE

SCALE:
N.T.S.

APPROVED:

REVISED:
2/24

POST MOUNTED SIGN WITH NO SHOULDER

SECTION #
85.04

DETAIL #
85-18

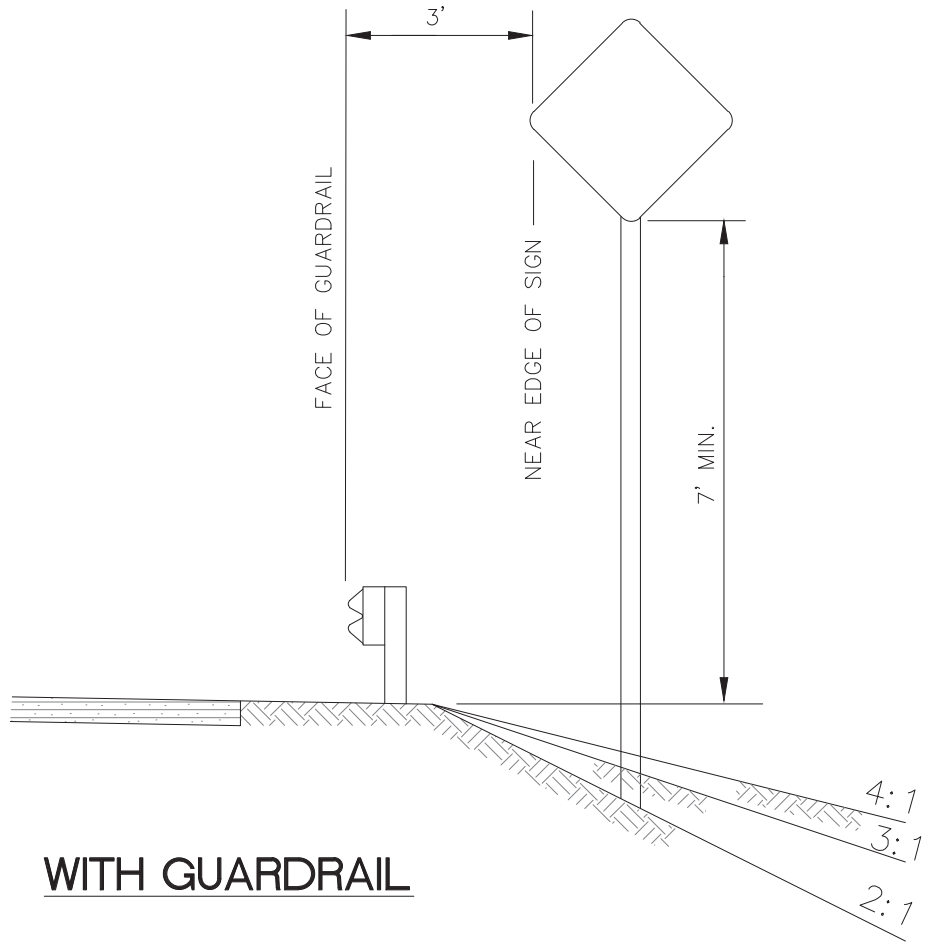

WITH GUARDRAIL

NOTES:

1. IF SIGNS EXTEND OVER SIDEWALKS, THE MINIMUM VERTICAL CLEARANCE IS 7'-0".
2. ADD 6" TO MOUNTING HEIGHT ON UNPAVED ROADS.
3. IF SIGNS EXTEND OVER BIKE PATHS, THE MINIMUM VERTICAL CLEARANCE IS 8'-0".
4. PAINT ALL SIGN MOUNTING FASTENERS ON SIGN FACE A COLOR MATCHING THE SIGN FACE.
5. ATTACH ALL SIGN FRAMING AND BRACES MOUNTED TO THE POSTS WITH 5/16" BOLTS WITH SELF-LOCKING NUTS.

REVISION: 2024 M.A.S.S. UPDATE



SCALE:
N.T.S.
APPROVED:
REVISD:
2/24

**POST MOUNTED SIGN
WITH GUARDRAIL**

SECTION #
85.04

DETAIL #
85-19

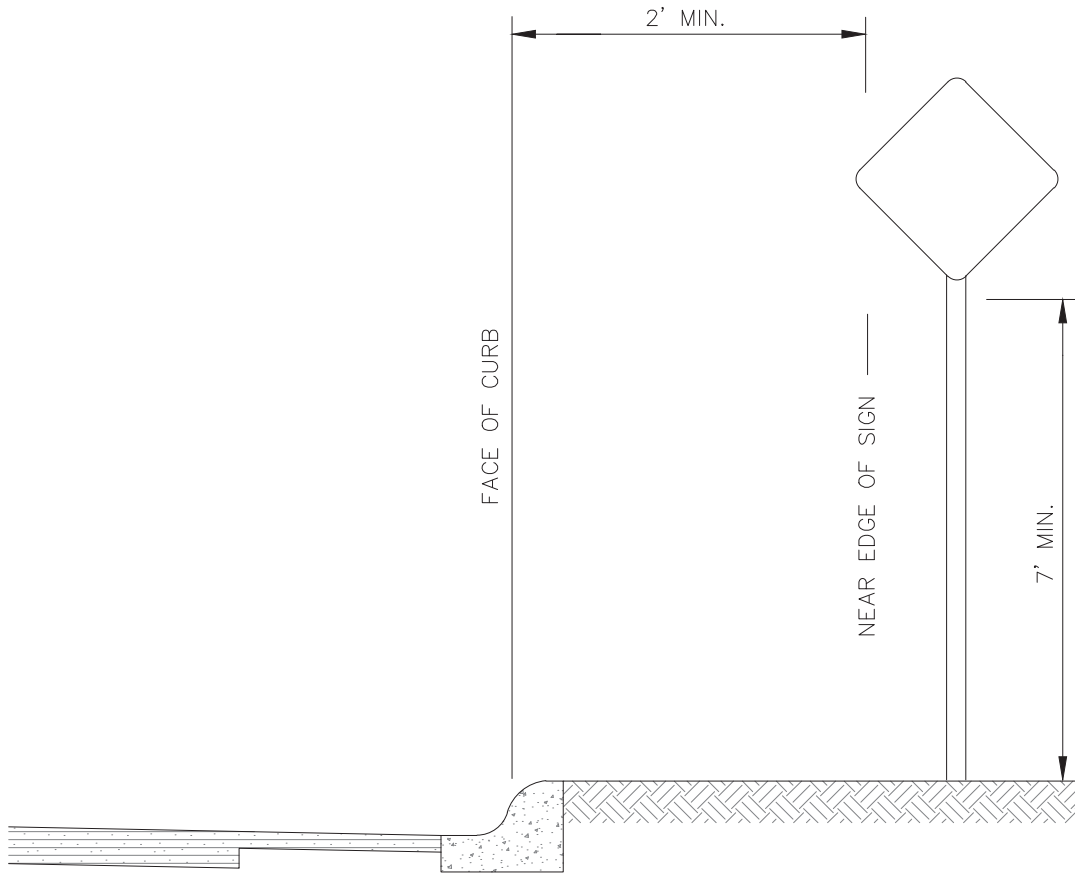

CURB WITHOUT SIDEWALK

NOTES:

1. PAINT ALL SIGN MOUNTING FASTENERS ON SIGN FACE A COLOR MATCHING THE SIGN FACE.
2. ATTACH ALL SIGN FRAMING AND BRACES MOUNTED TO THE POSTS WITH 5/16" BOLTS WITH SELF-LOCKING NUTS.

REVISION: 2024 M.A.S.S. UPDATE



SCALE:
N.T.S.

APPROVED:

REVISED:
2/24

POST MOUNTED SIGN CURB WITHOUT SIDEWALK

SECTION #
85.04

DETAIL #
85-20

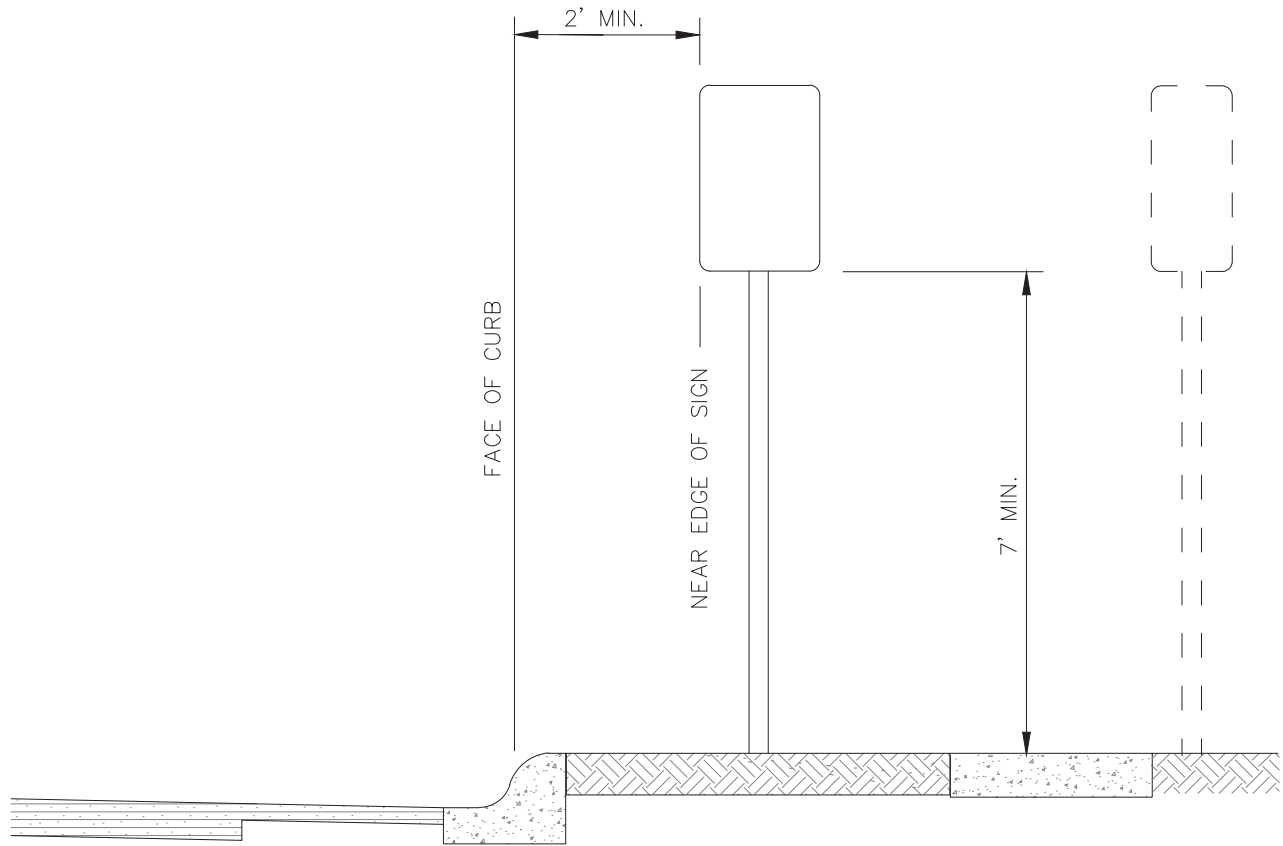

CURB WITH PARKWAY AND SIDEWALK

NOTES:

1. IF PARKWAY IS LESS THAN 5', SIGNS SHOULD BE PLACED BEHIND SIDEWALK.
2. IF SIGNS EXTEND OVER SIDEWALKS, THE MINIMUM VERTICAL CLEARANCE IS 7'-0".
3. IF SIGNS EXTEND OVER BIKE PATHS, THE MINIMUM VERTICAL CLEARANCE IS 8'-0".
4. PAINT ALL SIGN MOUNTING FASTENERS ON SIGN FACE A COLOR MATCHING THE SIGN FACE.
5. ATTACH ALL SIGN FRAMING AND BRACES MOUNTED TO THE POSTS WITH 5/16" BOLTS WITH SELF-LOCKING NUTS.

REVISION: 2024 M.A.S.S. UPDATE

 MUNICIPALITY OF ANCHORAGE	SCALE: N.T.S. APPROVED: REVISED: 2/24	<h1 style="margin: 0;">POST MOUNTED SIGN CURB WITH PARKWAY AND SIDEWALK</h1>	SECTION # 85.04 DETAIL # 85-21
---	---	--	---

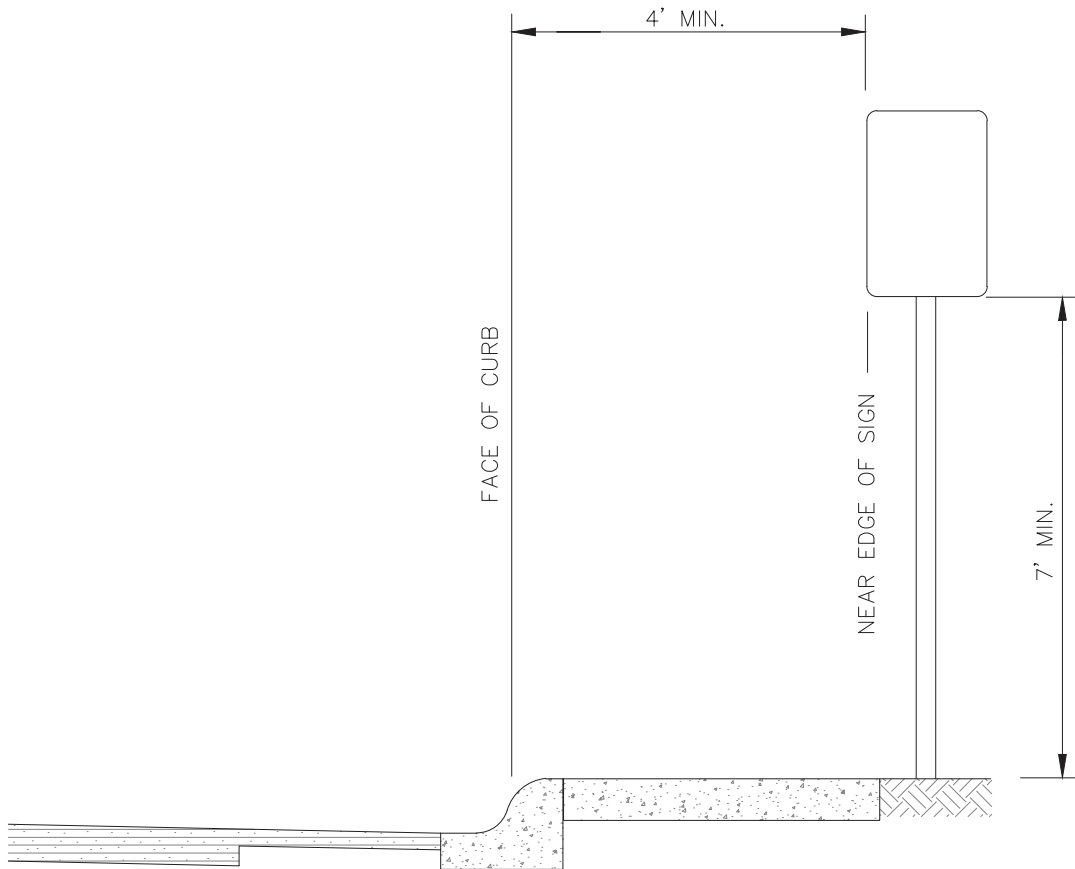

CURB WITH ATTACHED SIDEWALK

NOTE:

1. SIGN FACE SHALL BE PLACED OUTSIDE SIDEWALK EXCEPT WHEN ROW LIMITATIONS EXIST; FOR EXAMPLE IN THE CENTRAL BUSINESS DISTRICT OR OTHER SIMILAR DISTRICTS.

REVISION: 2024 M.A.S.S. UPDATE

 MUNICIPALITY OF ANCHORAGE	SCALE: N.T.S. APPROVED: REVISED: 2/24	POST MOUNTED SIGN CURB WITH SIDEWALK WITHOUT PARKWAY	SECTION # 85.04 DETAIL # 85-22
---	---	---	---

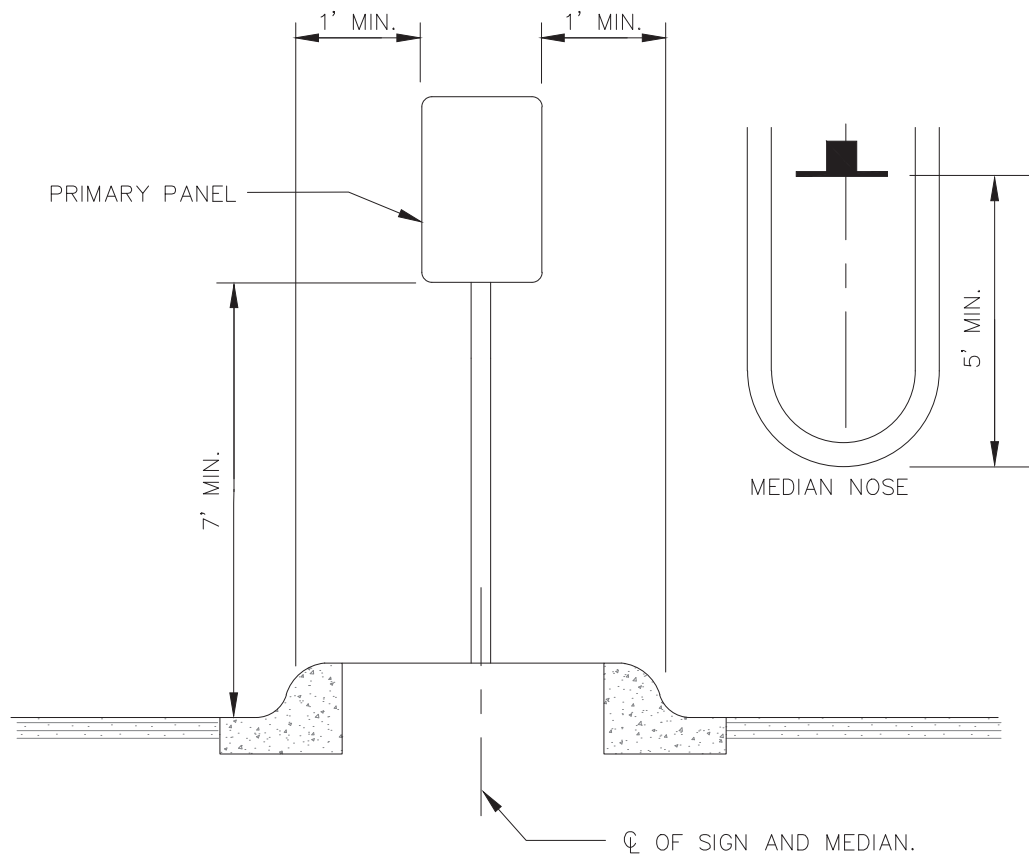

RAISED MEDIAN

NOTE:

IF AN OBJECT MARKER IS REQUIRED BY THE TRAFFIC ENGINEER, THE SIGN SHALL HAVE A MINIMUM FOUR FOOT (4') CLEARANCE FROM THE TOP OF MEDIAN TO THE BOTTOM OF SIGN.

REVISION: 2024 M.A.S.S. UPDATE



SCALE:
N.T.S.
APPROVED:
REVISED:
2/24

POST MOUNTED SIGN RAISED MEDIANS

SECTION #
85.04
DETAIL #
85-23

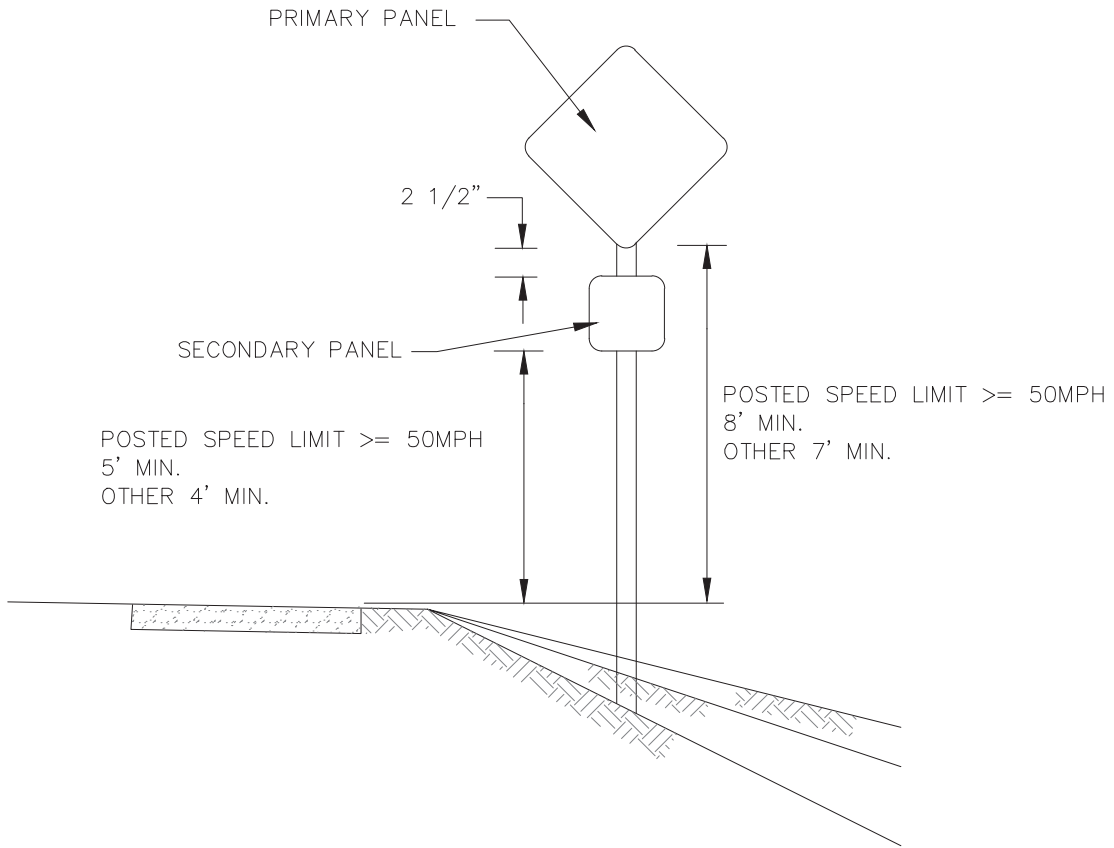

**SECONDARY PANEL HEIGHT
ALL TWO PANEL MOUNTING**

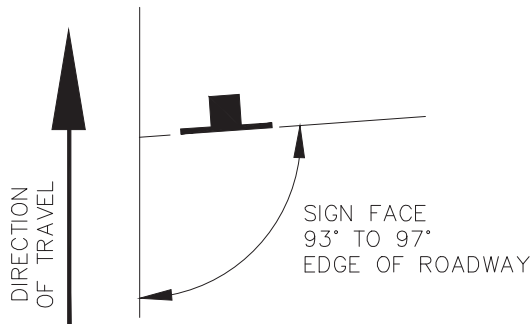

SIGN POSITIONING

REVISION: 2024 M.A.S.S. UPDATE

MUNICIPALITY



OF ANCHORAGE

SCALE:
N.T.S.

APPROVED:

REVISED:
2/24

**POST MOUNTED SIGN
SECONDARY PANEL HEIGHT
AND SIGN POSITIONING**

SECTION #
85.04

DETAIL #
85-24

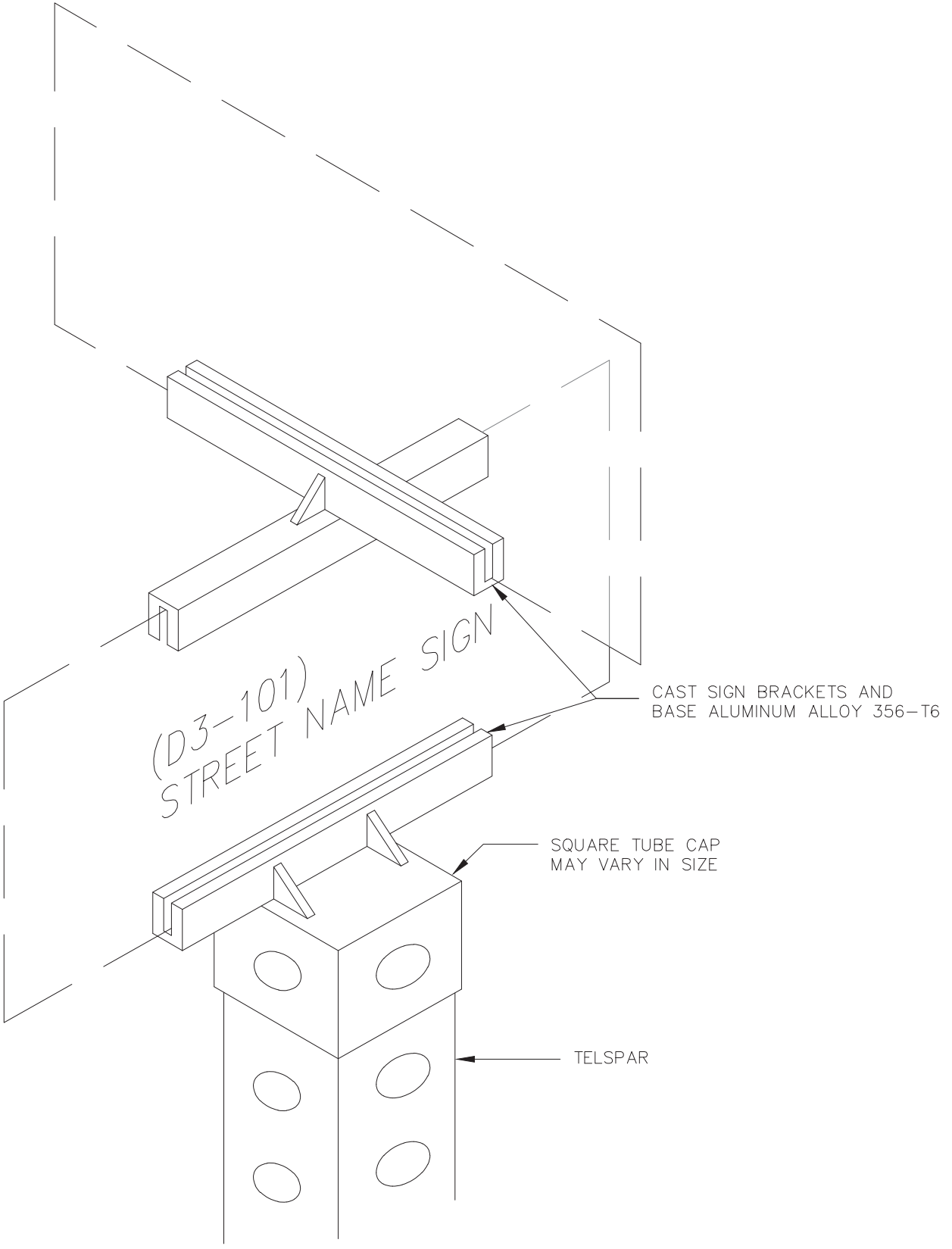

REVISION: 2024 M.A.S.S. UPDATE

MUNICIPALITY



OF ANCHORAGE

SCALE:
N.T.S.

APPROVED:

REVISED:
2/24

STREET NAME SIGNS

SECTION #
85.04

DETAIL #
85-25

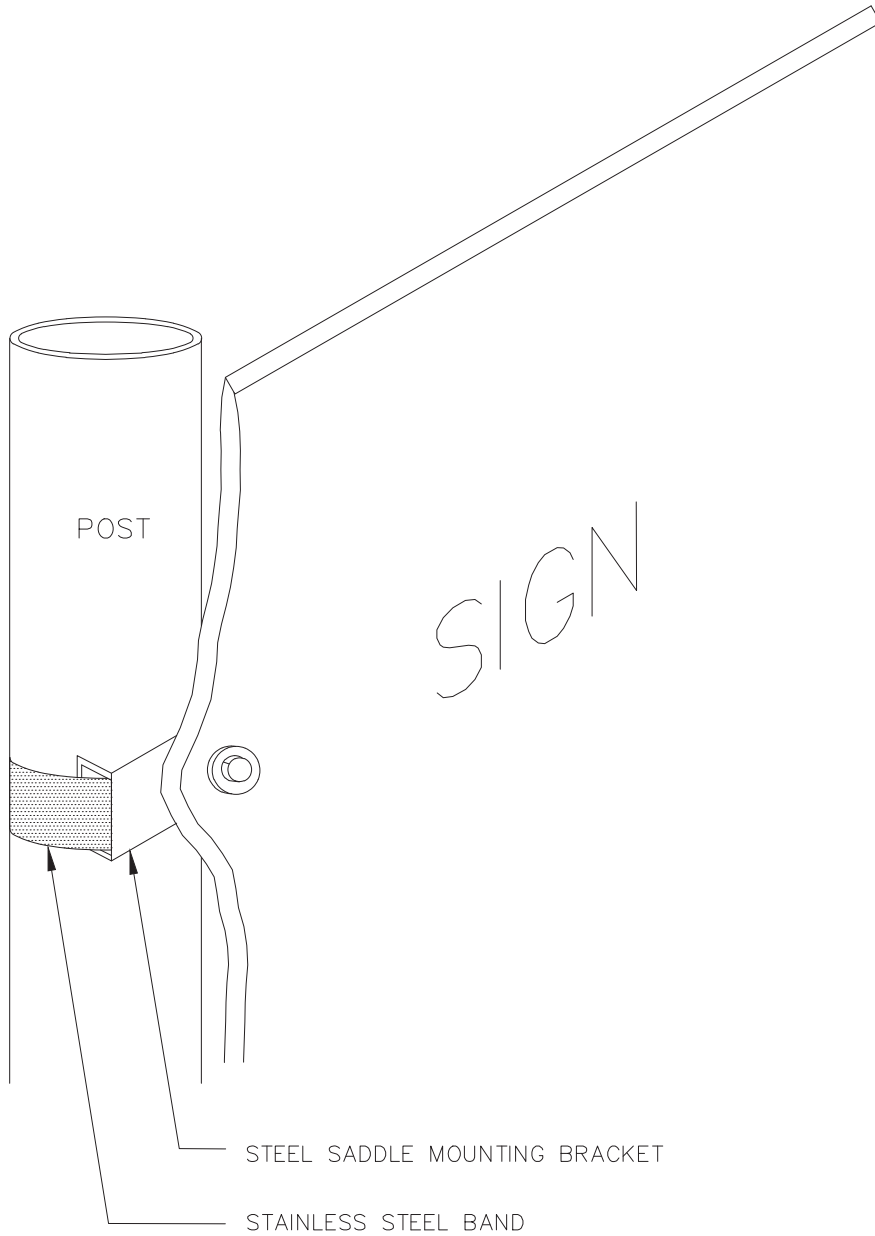

REVISION: 2024 M.A.S.S. UPDATE

MUNICIPALITY



OF ANCHORAGE

SCALE:
N.T.S.

APPROVED:

REVISED:
2/24

SIGN ON ROUND POST

SECTION #
85.04

DETAIL #
85-26

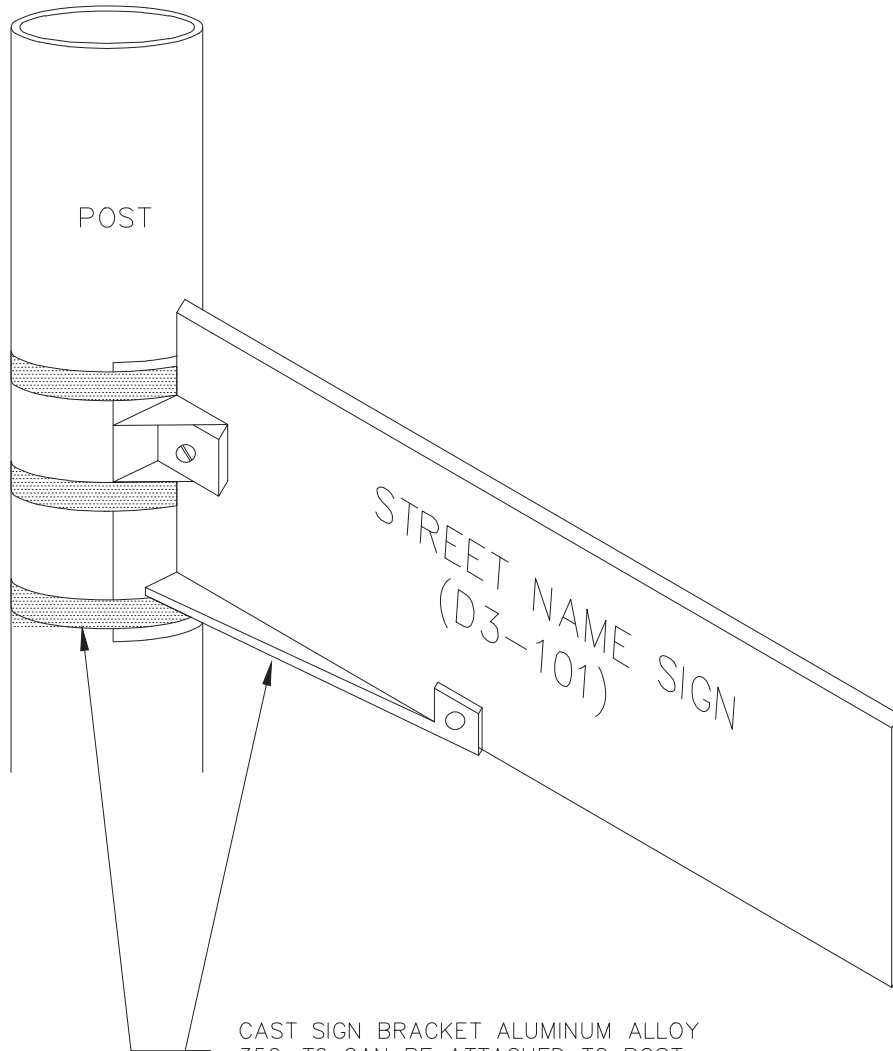

CAST SIGN BRACKET ALUMINUM ALLOY
356-T6 CAN BE ATTACHED TO POST
WITH STAINLESS STEEL STRAPS.

REVISION: 2024 M.A.S.S. UPDATE

MUNICIPALITY



OF ANCHORAGE

SCALE:
N.T.S.

APPROVED:

REVISED:
2/24

STREET NAME ON ROUND POST

SECTION #
85.04

DETAIL #
85-27

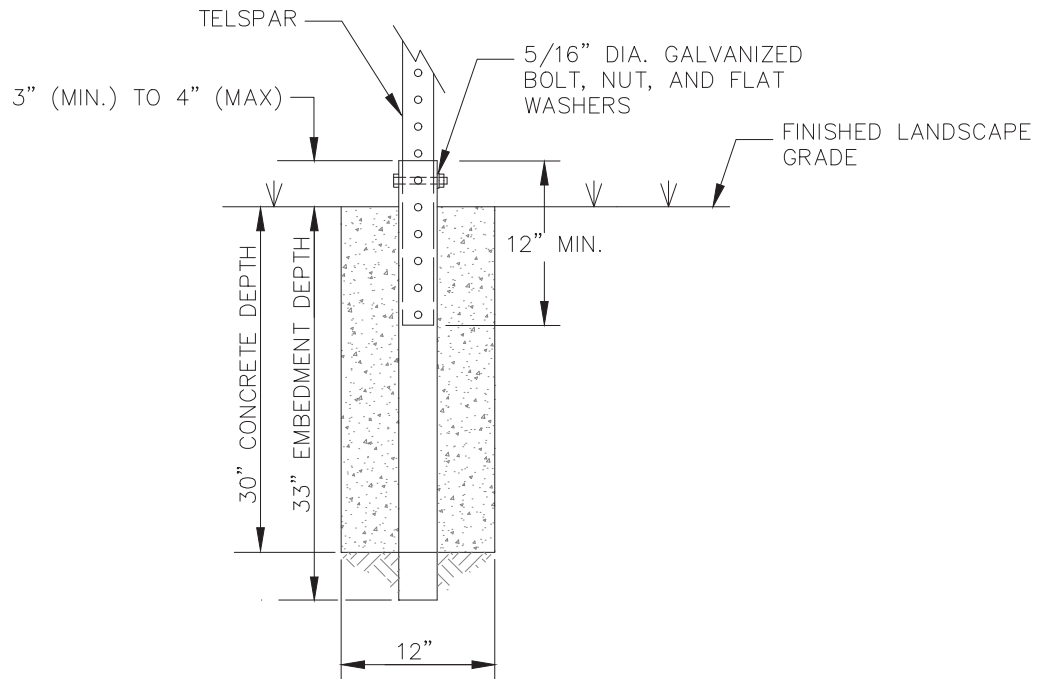

CONCRETE FOUNDATION FOR SIGN POST

NOTES:

1. TELSPAR SHALL BE 2 ½" X 2 ½" PERFORATED STEEL TUBES (P.S.T.), (12ga.—105 WALL THICKNESS).
2. EMBEDDED DEPTHS 33", CONCRETE DEPTH 30"
3. SEPARATE SIGN INSTALLATIONS ARE NOT PERMITTED WITHIN 7' OF EACH OTHER.

REVISION: 2024 M.A.S.S. UPDATE

MUNICIPALITY



OF ANCHORAGE

SCALE:
N.T.S.

APPROVED:

REVISED:
2/24

CONCRETE FOUNDATION FOR SIGN POST

SECTION #
85.04

DETAIL #
85-28

**RIVET DETAIL
ELEVATION VIEW**

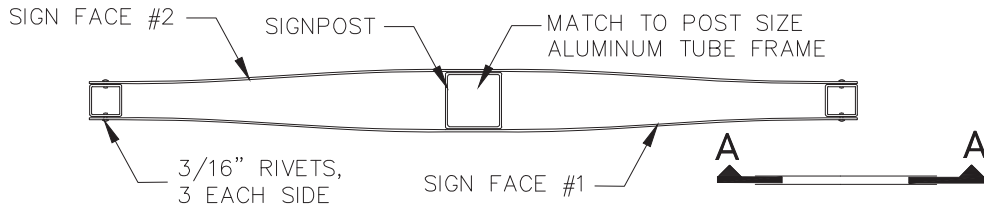
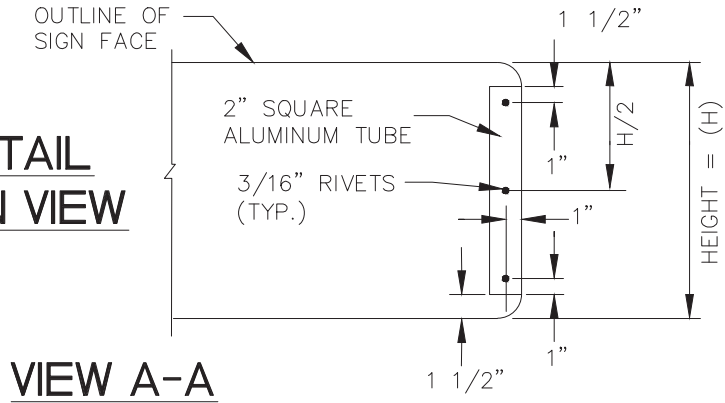

PLAN VIEW

**12" SIGNS/PLATES 36" OR GREATER IN LENGTH
BRACING DETAIL**

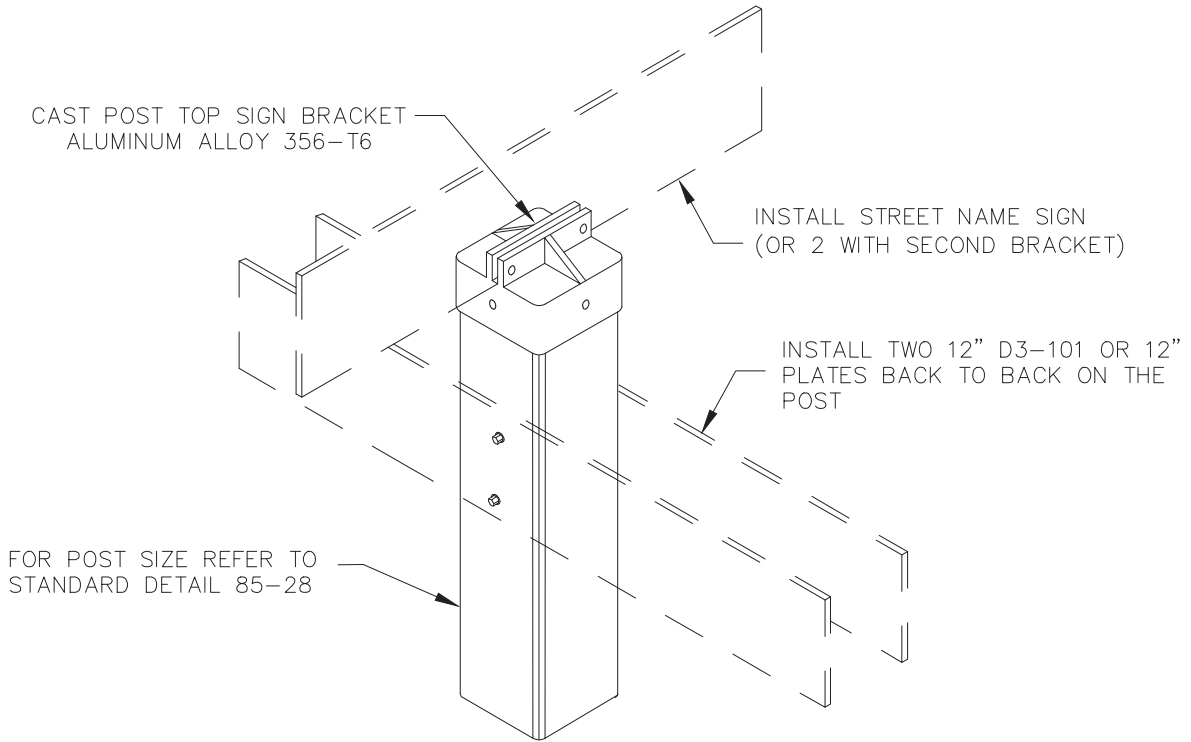

REVISION: 2024 M.A.S.S. UPDATE

MUNICIPALITY



OF ANCHORAGE

SCALE:
N.T.S.

APPROVED:

REVISED:
2/24

**12" PLATE INSTALLATION DETAIL
WITH
SUPPLEMENTAL 8" D3-101 SIGNS**

SECTION #
85.04

DETAIL #
85-29

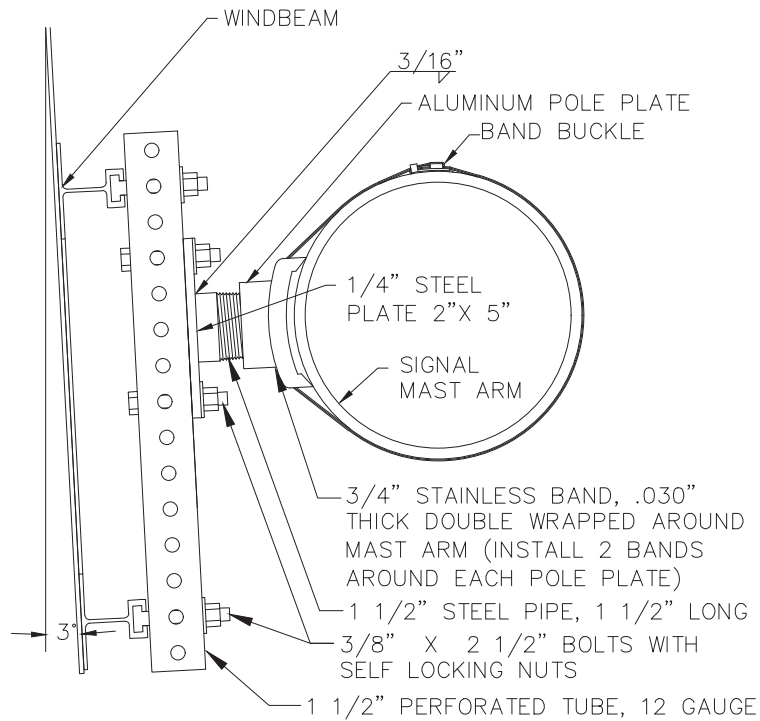

TABLE 1

POLE PLATE SPACING

NO. OF POLE PLATES	OVERHANG	BETWEEN POLE PLATES	OVERHANG
2	0.2W	1 SPACE AT 0.6W 2	0.2W
3	0.15W	SPACES AT 0.35W 3	0.15W
4	0.125W	SPACES AT 0.25W 1	0.125W
5	0.2W	SPACE AT 0.6W	0.2W

NOTES:

- USE POLE PLATE ASSEMBLIES TO INSTALL SIGNS ON TAPERED MAST ARMS AND SIGNS REQUIRING FRAMING ON LIGHT POLES.
- FOR SIGNS ON MAST ARMS INSTALL A MINIMUM OF TWO POLE PLATES FOR EACH SIGN. INSTALL AN ADDITIONAL POLE PLATE PER 10 SQUARE FEET OF SIGN.
- FOR SIGNS ON MAST ARMS MAINTAIN MINIMUM 18' UNDER CLEARANCE FROM THE VEHICULAR TRAVELED WAY.

REVISION: 2024 M.A.S.S. UPDATE

MUNICIPALITY



OF ANCHORAGE

SCALE:
N.T.S.

APPROVED:

REVISED:
2/24

SIGNAL POLE MAST ARM SIGN MOUNTING

SECTION #
85.04

DETAIL #
85-30

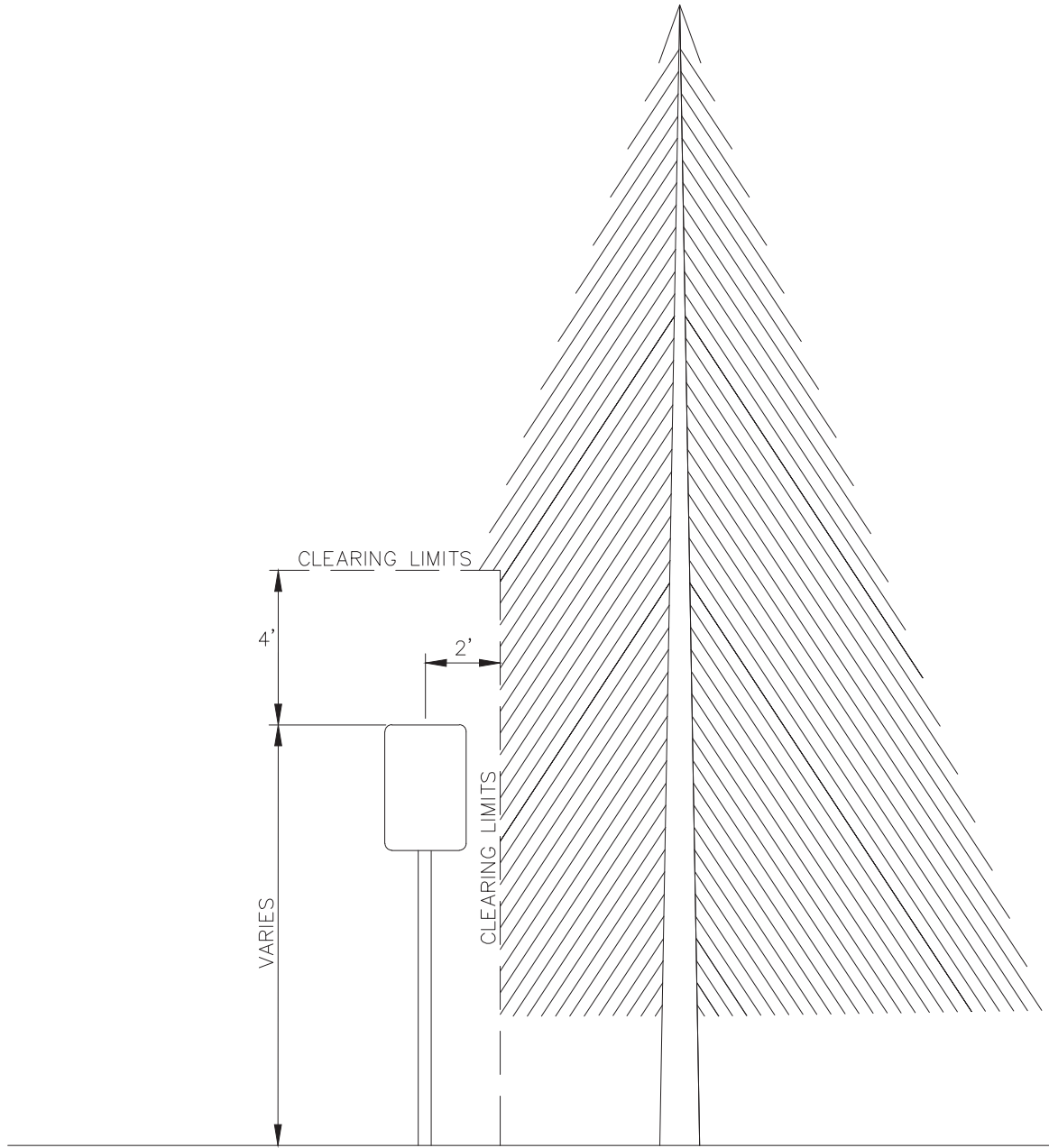

CLEARING FOR SIGNS

1. MAINTAIN CLEARING LIMITS WITHIN AVAILABLE RIGHT OF WAY.
2. ALL CLEARING ACTIVITIES SHALL BE PERFORMED BY AN ARBORIST IN ACCORDANCE WITH SECTION 20.05 CLEARING.

REVISION: 2024 M.A.S.S. UPDATE

 <p>MUNICIPALITY OF ANCHORAGE</p>	<p>SCALE: N.T.S.</p> <p>APPROVED:</p> <p>REVISED: 2/24</p>	<h1 style="margin: 0;">CLEARING FOR SIGNS</h1>	<p>SECTION # 85.04</p> <p>DETAIL # 85-31</p>
--	--	--	--

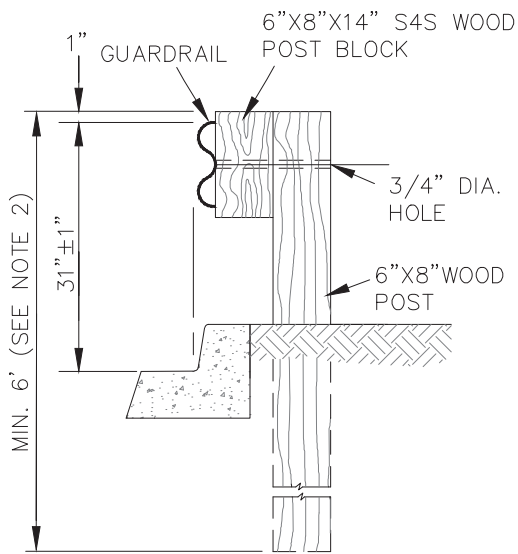
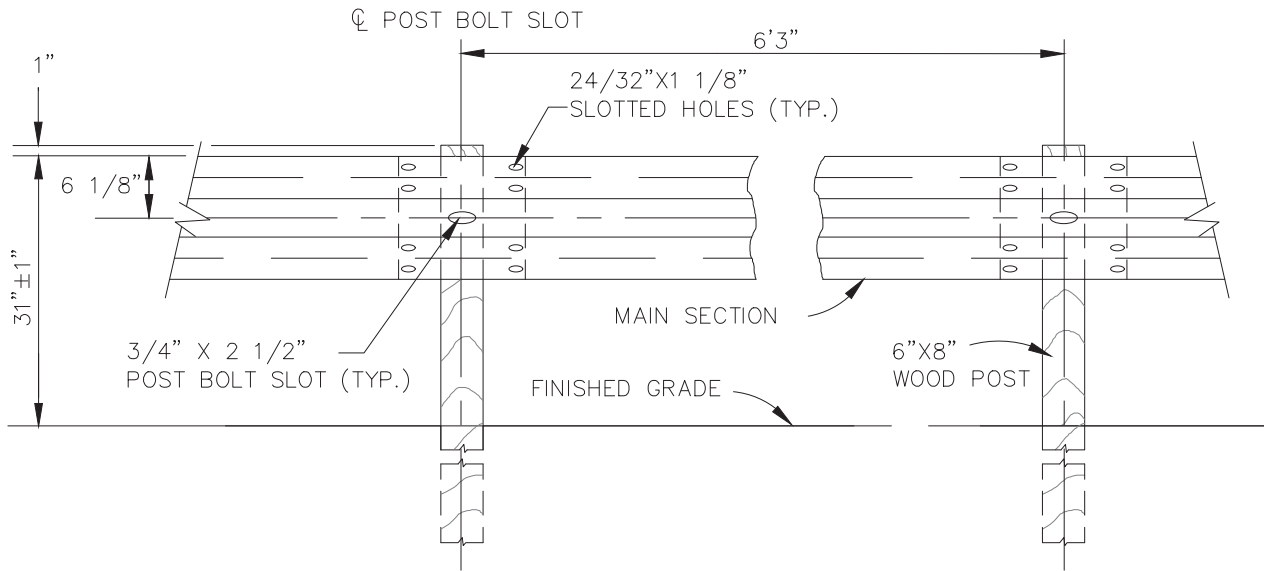

WOOD POST

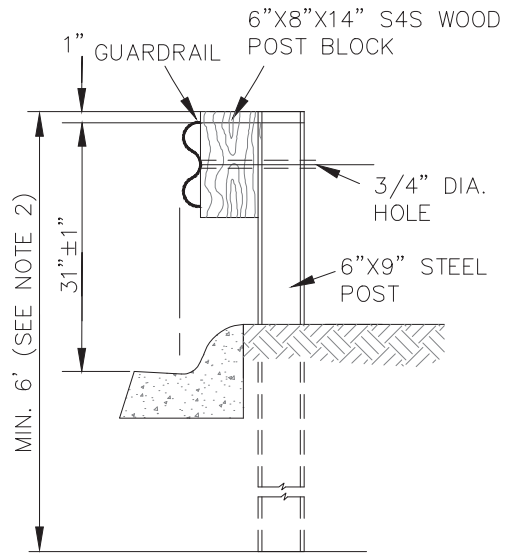

STEEL POST

NOTES:

1. PROVIDE GUARDRAIL OF TYPE AND GAUGE SPECIFIED IN THE CONTRACT DOCUMENTS.
2. WHEN INFORMATION IS NOT INCLUDED IN THE CONTRACT DOCUMENTS, SEE ADOT&PF STANDARD PLAN G-10 FOR GUARDRAIL POST LENGTHS CORRESPONDING TO COMBINATIONS OF SLOPE AND BEHIND-POST EMBANKMENT WIDTHS.
3. WHEN INFORMATION IS NOT INCLUDED IN THE CONTRACT DOCUMENTS, SEE ADOT&PF STANDARD PLANS G-14 AND G-20 FOR GUARDRAIL END TREATMENT DETAILS.

REVISION: 2024 M.A.S.S. UPDATE



SCALE:
N.T.S.
APPROVED:
REVISD:
2/24

GUARDRAIL DETAIL

SECTION #
85.07

DETAIL #
85-32

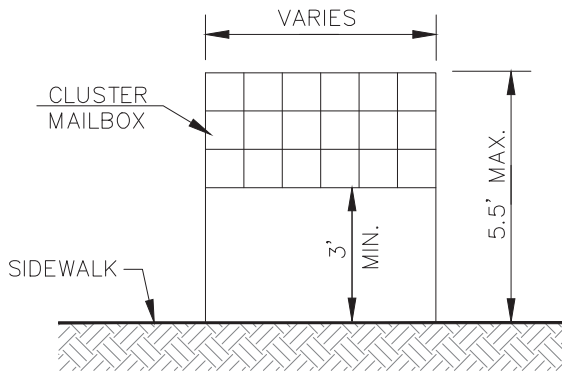

FRONT VIEW

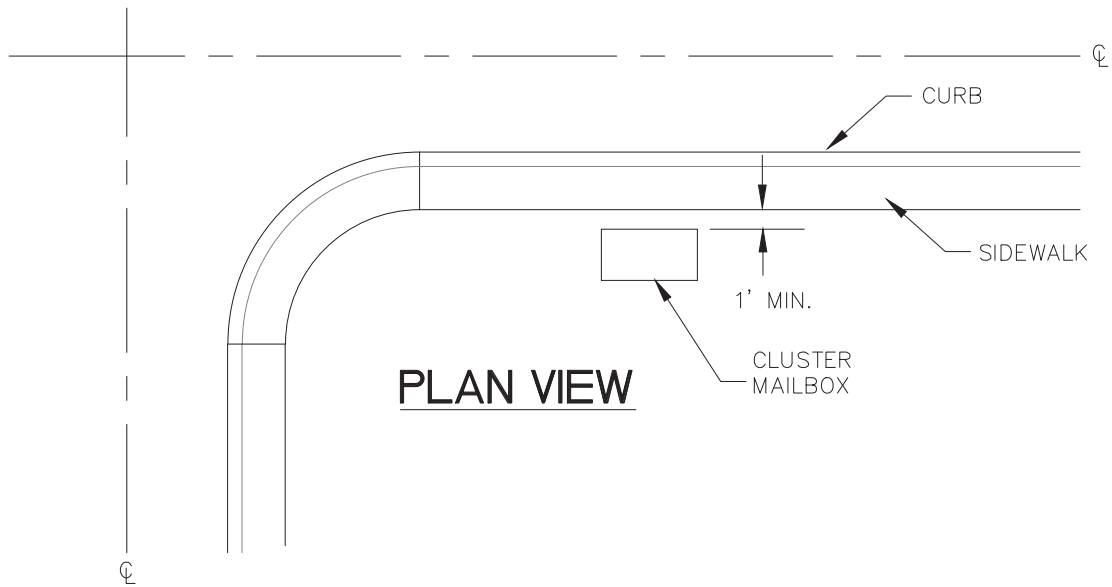
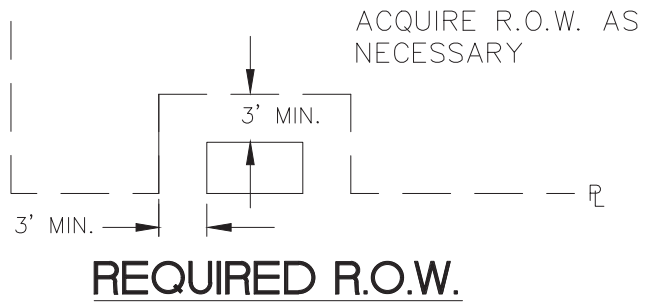

NOTE:

1. COORDINATE WITH LOCAL POSTAL AUTHORITIES TO DETERMINE LOCATIONS OF CLUSTER MAILBOXES. IF CLUSTERING OR SPECIAL LOCATIONS ARE SPECIFIED, PROVISIONS SHALL BE INCLUDED IN THE CONTRACT DOCUMENTS.

REVISION: 2024 M.A.S.S. UPDATE



SCALE:
N.T.S.

APPROVED:

REVISED:
2/24

CLUSTER MAILBOX LOCATION

SECTION #
85.08,
85.09

DETAIL #
85-33

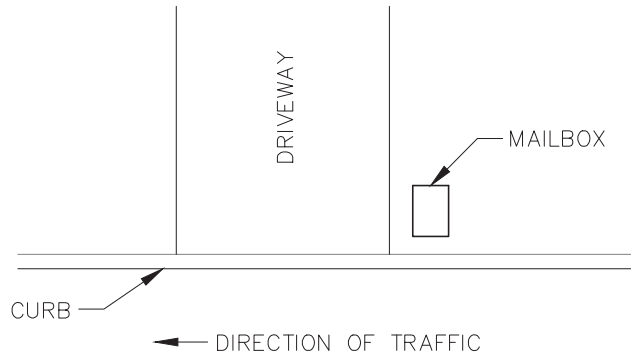

PLAN VIEW

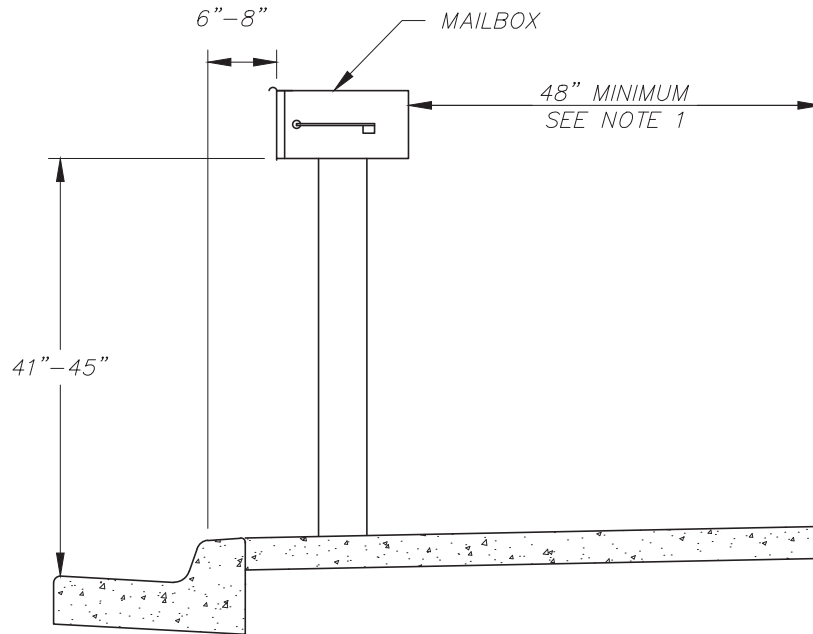

MAILBOX LOCATION

NOTES:

1. WHERE MAILBOX IS LOCATED WITHIN SIDEWALK, PROVIDE 4 FOOT MINIMUM WIDE CLEAR PEDESTRIAN ACCESS ROUTE.
2. COORDINATE WITH LOCAL POSTAL AUTHORITIES TO DETERMINE LOCATION OF MAILBOX. IF SPECIAL LOCATION IS SPECIFIED, PROVISIONS SHALL BE INCLUDED IN THE CONTRACT DOCUMENTS.

REVISION: 2024 M.A.S.S. UPDATE

 <p>MUNICIPALITY OF ANCHORAGE</p>	<p>SCALE: N.T.S.</p> <p>APPROVED:</p> <p>REVISED: 2/24</p>	<p>MAILBOX LOCATION</p>	<p>SECTION # 85.09</p> <p>DETAIL # 85-34</p>
--	--	--------------------------------	--

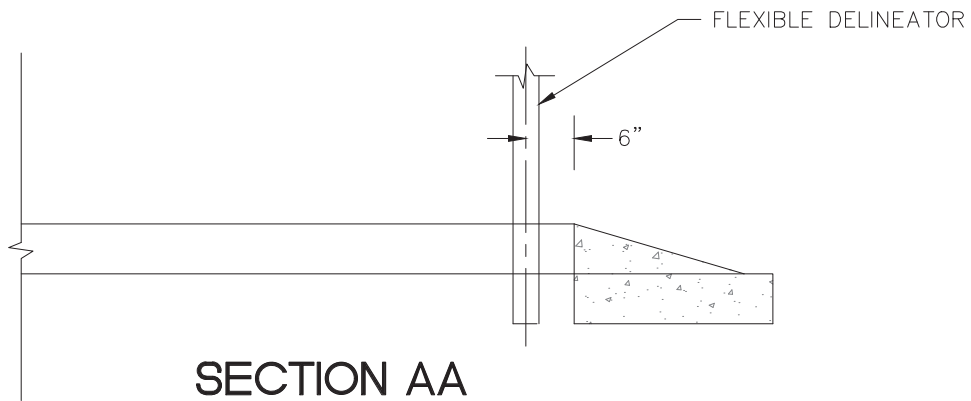
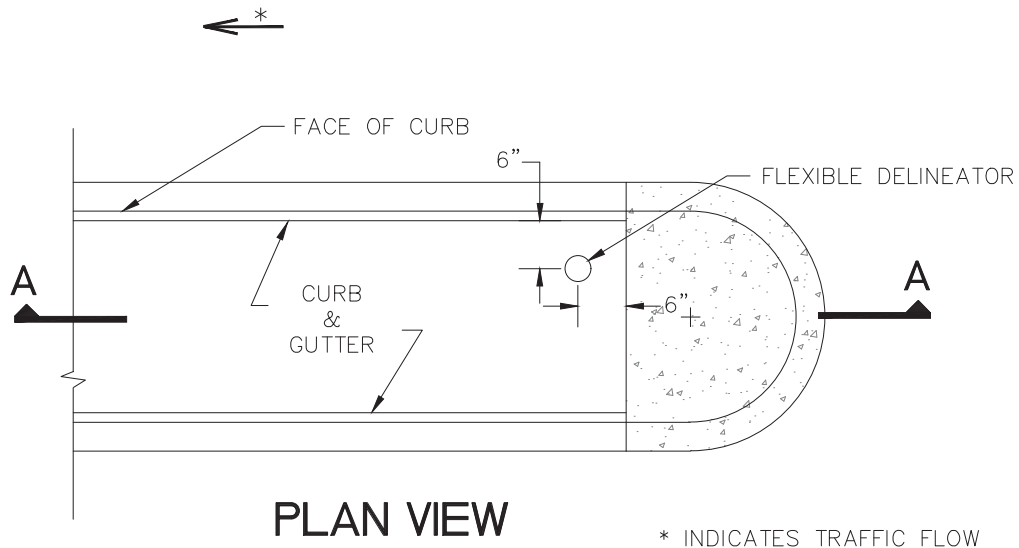

FLEXIBLE DELINEATOR

SEE DETAIL 30-4 FOR MEDIAN/CURB NOSE DETAILS.

REVISION: 2024 M.A.S.S. UPDATE



SCALE:
N.T.S.

APPROVED:

REVISED:
2/24

FLEXIBLE DELINEATOR

SECTION #
85.10

DETAIL #
85-35

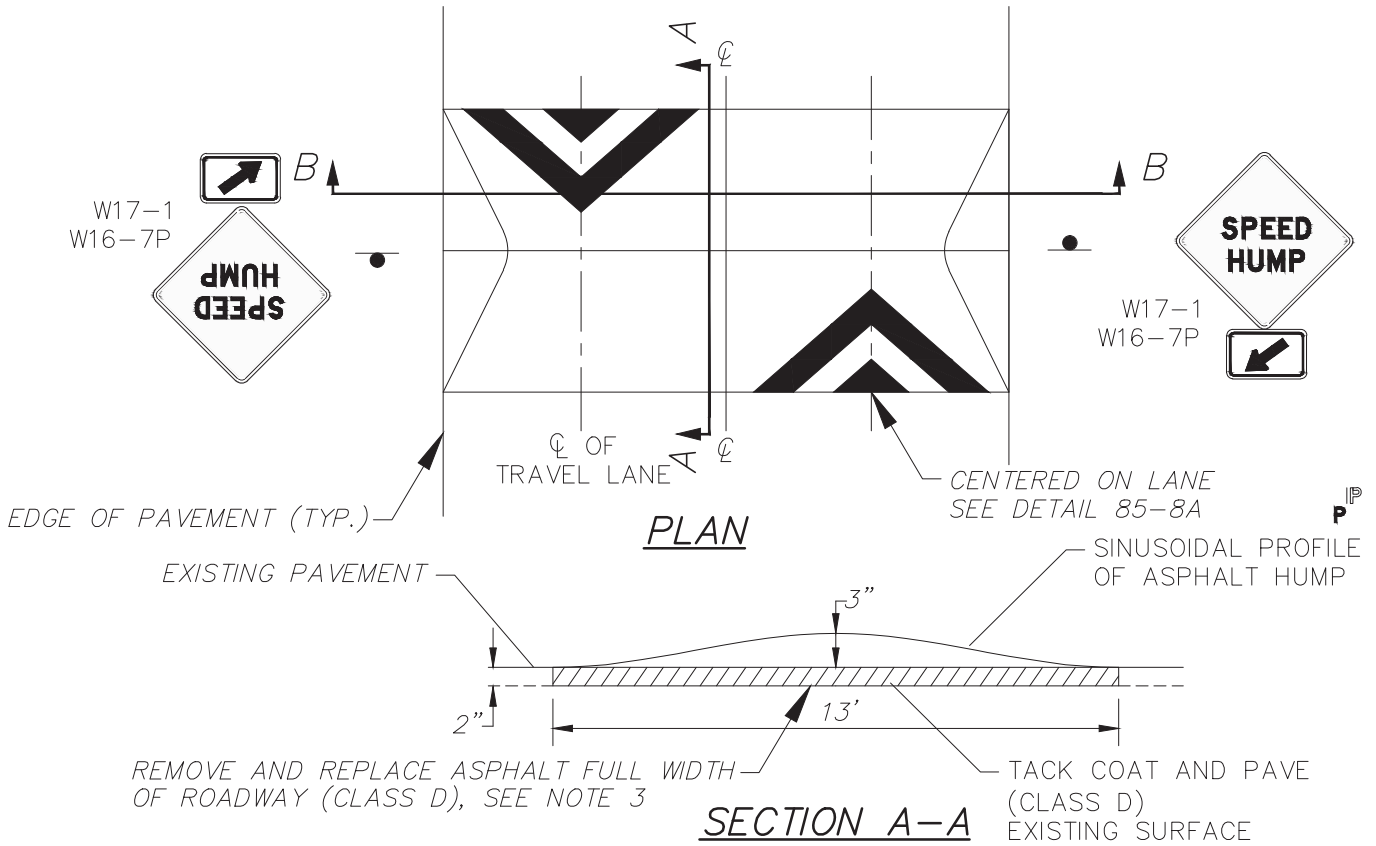

SPEED HUMP NOTES:

1. CONTRACTOR SHALL CONSTRUCT SPEED HUMPS AS SHOWN IN SECTION BB TO ENSURE THAT DRAINAGE IS NOT OBSTRUCTED ALONG THE EDGE OF THE ROADWAY.
2. ASPHALT THICKNESS SHALL BE WITHIN PLUS OR MINUS 0.25" OF THICKNESS SHOWN.
3. SPEED HUMP STRIPING SHALL BE 90 MIL INLAID METHYL METHACRYLATE. SPEED HUMP STRIPING SHALL BE INCIDENTAL TO THE CONSTRUCTION OF THE SPEED HUMP AND NO ADDITIONAL PAYMENT SHALL BE MADE.
4. IF SINUSOIDAL SPEED HUMP ARE INSTALLED WITHIN 15 DAYS OF ROADWAY ASPHALT PLACEMENT, THE NEWLY PAVED SURFACE IS NOT REQUIRED TO BE REMOVED AND REPLACED. TACK COAT SHALL BE APPLIED BETWEEN THE NEWLY PAVED SURFACE AND THE FLAT TOP SPEED HUMP.

LIP OF GUTTER OR EDGE OF PAVEMENT

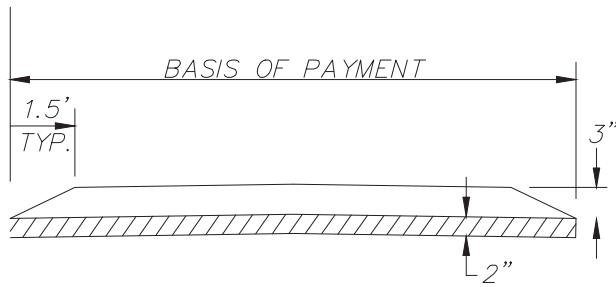

SECTION B-B

SINUSOIDAL PROFILE OF SPEED HUMP

DISTANCE (ft)	0.00	0.41	0.82	1.23	1.64	2.05	2.46	2.87
FINISHED HEIGHT (in)	0.00	0.04	0.12	0.26	0.47	0.71	0.98	1.26
DISTANCE (ft)	3.69	4.10	4.51	4.92	5.33	5.74	6.00	6.50
FINISHED HEIGHT (in)	1.89	2.17	2.44	2.68	2.87	2.95	3.00	3.00

REVISION: 2024 M.A.S.S. UPDATE



SCALE:
N.T.S.

APPROVED:

REVISED:
2/24

SINUSOIDAL SPEED HUMP

SECTION #
85.11

DETAIL #
85-36

CENTERED ON LANE
SEE DETAIL 85-8A

LIP OF
GUTTER OR
EDGE OF
PAVEMENT,
TYP.



W17-1
W16-7P

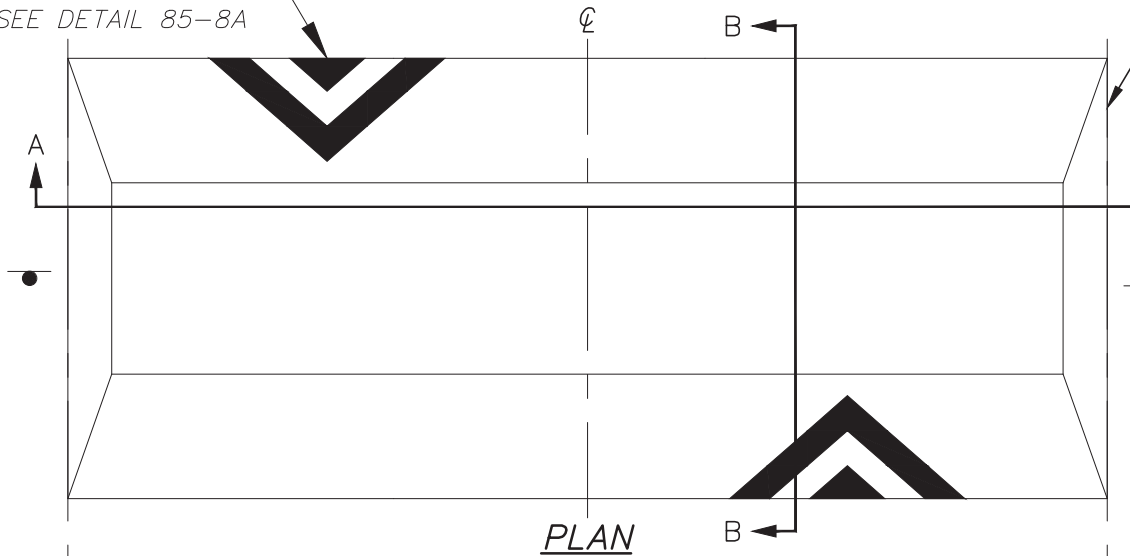

PLAN

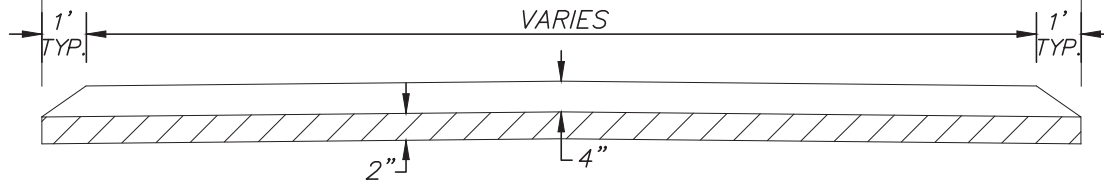

SECTION A-A

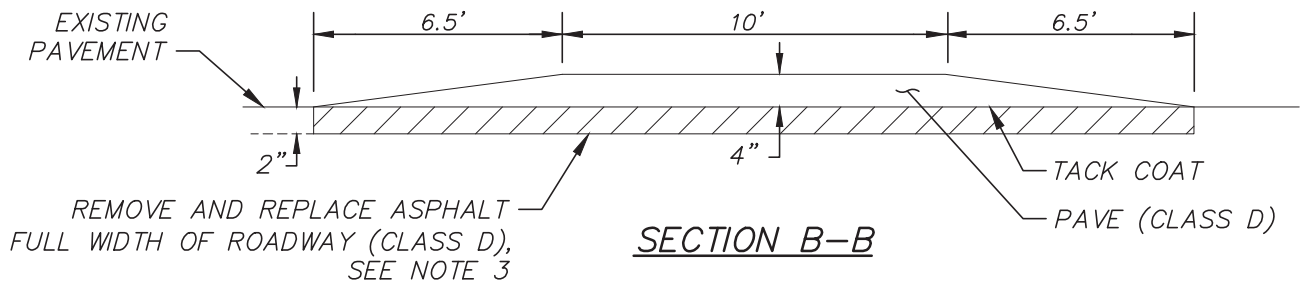

SECTION B-B

ASPHALT FLAT TOP SPEED HUMP NOTES:

1. CONSTRUCT FLAT TOP SPEED HUMPS AS SHOWN IN SECTION A-A TO ENSURE THAT DRAINAGE IS NOT OBSTRUCTED ALONG THE EDGE OF THE ROADWAY.
2. ASPHALT THICKNESS SHALL BE WITHIN PLUS OR MINUS 0.25" OF THICKNESS SHOWN.
3. IF ASPHALT FLAT TOP SPEED HUMP ARE INSTALLED WITHIN 15 DAYS OF ROADWAY ASPHALT PLACEMENT, THE NEWLY PAVED SURFACE IS NOT REQUIRED TO BE REMOVED AND REPLACED. TACK COAT SHALL BE APPLIED BETWEEN THE NEWLY PAVED SURFACE AND THE FLAT TOP SPEED HUMP.
4. ASPHALT FLAT TOP SPEED HUMP STRIPING SHALL BE 90 MIL INLAID MMA. ASPHALT FLAT TOP SPEED HUMP SYMBOLS SHALL BE INCIDENTAL TO THE CONSTRUCTION OF THE ASPHALT FLAT TOP SPEED HUMP AND NO ADDITIONAL PAYMENT SHALL BE MADE.
5. PLACE ARROW SYMBOLS IN CENTER OF LANE. VERIFY WITH THE ENGINEER PRIOR TO PLACEMENT.

REVISION: 2024 M.A.S.S. UPDATE

MUNICIPALITY



OF ANCHORAGE

SCALE:
N.T.S.

APPROVED:

REVISED:
2/24

**ASPHALT FLAT TOP
SPEED HUMP**

SECTION #
85.11

DETAIL #
85-37

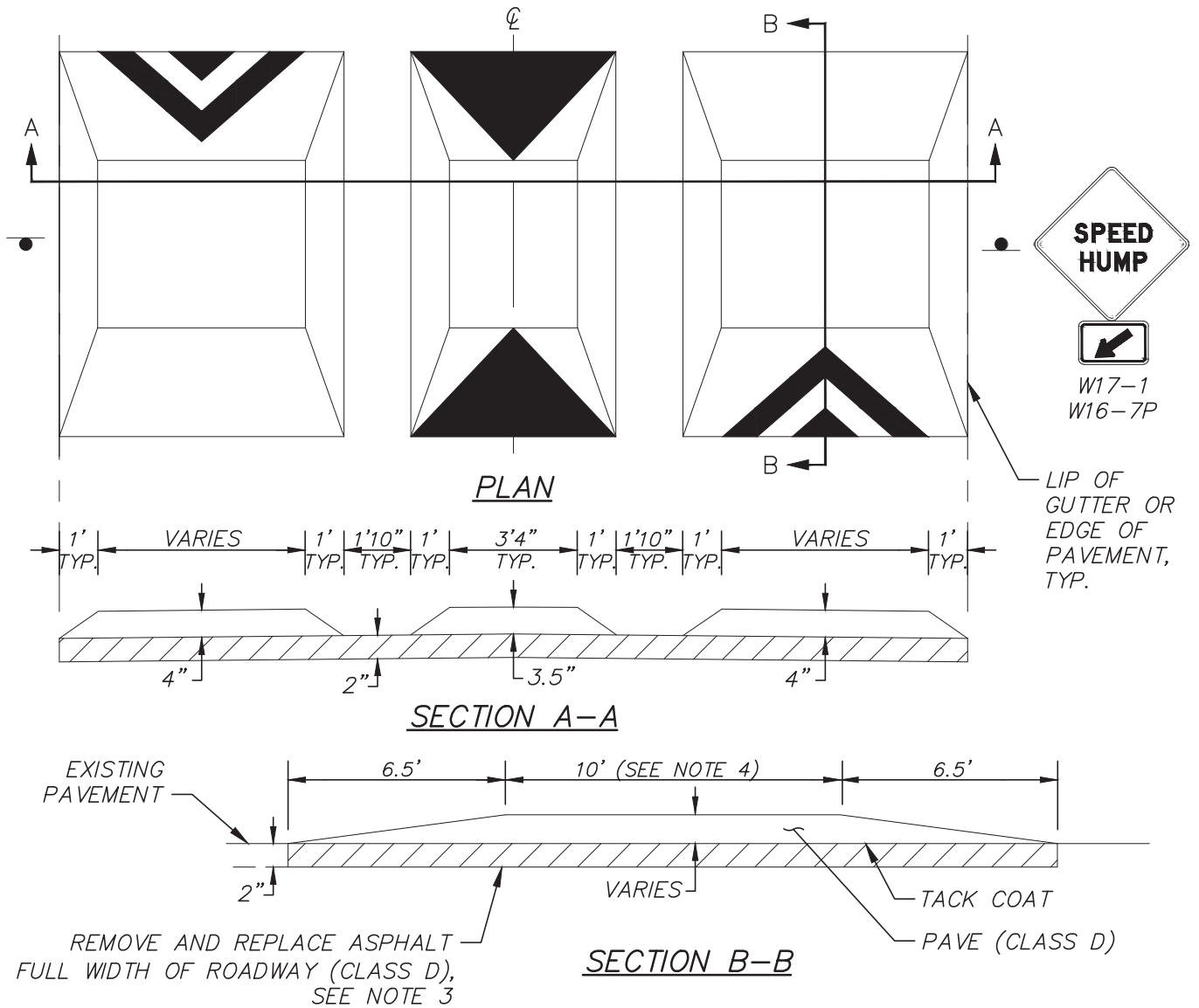

ASPHALT SPEED CUSHION NOTES:

1. CONSTRUCT SPEED CUSHIONS AS SHOWN IN SECTION A-A TO ENSURE THAT DRAINAGE IS NOT OBSTRUCTED ALONG THE EDGE OF THE ROADWAY.
2. ASPHALT THICKNESS SHALL BE WITHIN PLUS OR MINUS 0.25" OF THICKNESS SHOWN.
3. IF ASPHALT SPEED CUSHIONS ARE INSTALLED WITHIN 15 DAYS OF ROADWAY ASPHALT PLACEMENT, THE NEWLY PAVED SURFACE IS NOT REQUIRED TO BE REMOVED AND REPLACED. TACK COAT SHALL BE APPLIED BETWEEN THE NEWLY PAVED SURFACE AND THE SPEED CUSHIONS.
4. THE LENGTH OF THE FLAT TOP SECTION MAY BE REDUCED TO 8' WITH THE APPROVAL FROM THE TRAFFIC ENGINEER.
5. ASPHALT SPEED CUSHIONS SHALL NOT BE PLACED ON ROADWAYS LESS THAN 27.5' WIDE OR GRADES GREATER THAN 5.0%.
6. SEE M.A.S.S. SECTION 85.11 DETAIL 85-39 FOR SPEED CUSHION STRIPING.

REVISION: 2024 M.A.S.S. UPDATE



SCALE:
N.T.S.

APPROVED:

REVISED:
2/24

ASPHALT SPEED CUSHION

SECTION #
85.11

DETAIL #
85-38

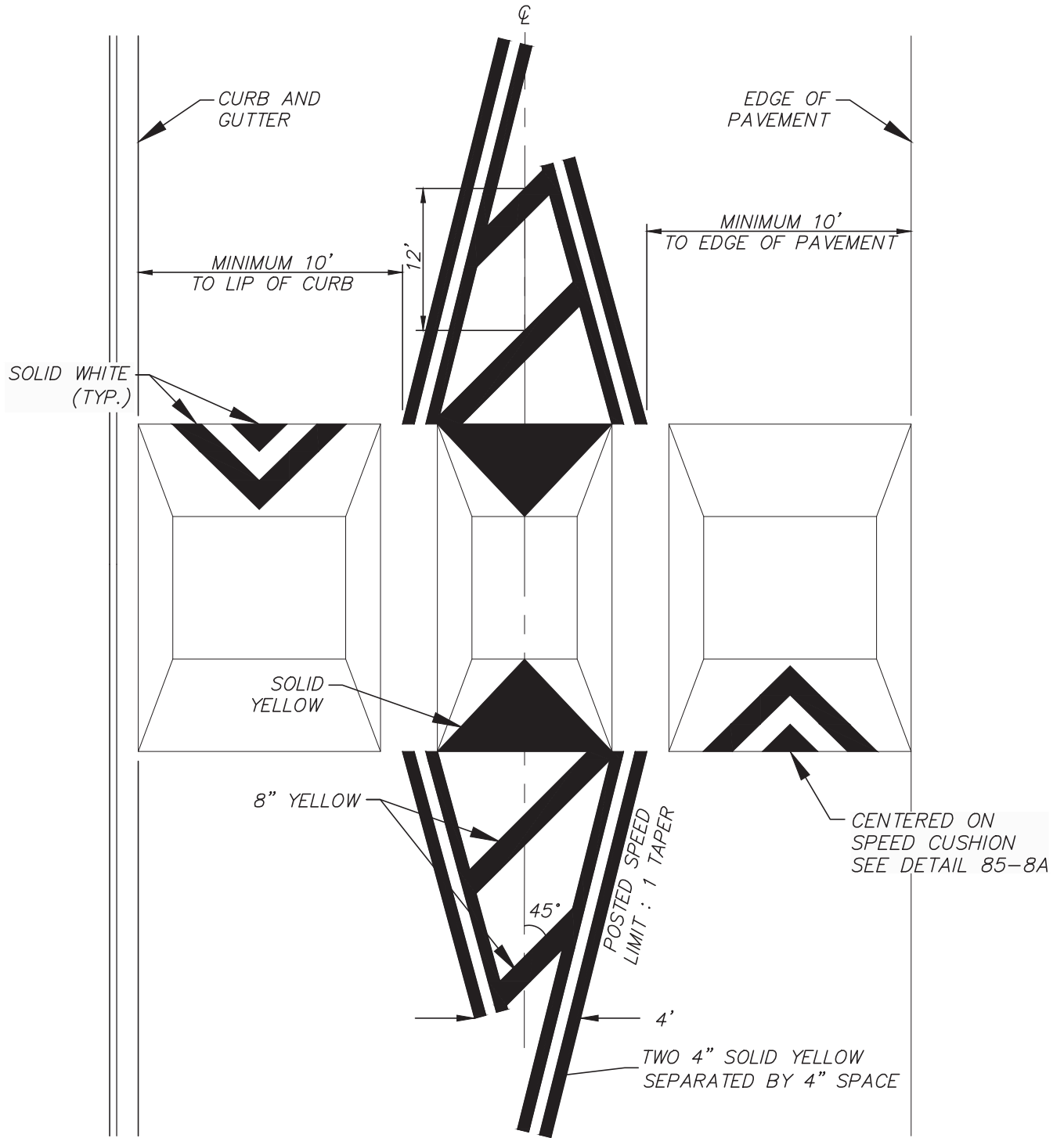

ASPHALT SPEED CUSHION STRIPING NOTES:

1. ASPHALT SPEED CUSHION STRIPING SHALL BE 90 MIL INLAID MMA. SYMBOLS LOCATED ON THE SPEED CUSHION SHALL BE INCIDENTAL TO THE CONSTRUCTION OF THE ASPHALT SPEED CUSHION AND NO ADDITIONAL PAYMENT SHALL BE MADE.
2. TAPER LENGTH MAY BE REDUCED WITH APPROVAL FROM THE ENGINEER.

REVISION: 2024 M.A.S.S. UPDATE

MUNICIPALITY

 OF ANCHORAGE

SCALE:
N.T.S.
 APPROVED:
 REVISED:
2/24

**ASPHALT SPEED CUSHION
STRIPING**

SECTION #
85.11
 DETAIL #
85-39

NOTES:

1. RAISED CROSSWALK NOTES ARE PROVIDED IN STANDARD DETAIL 85-41

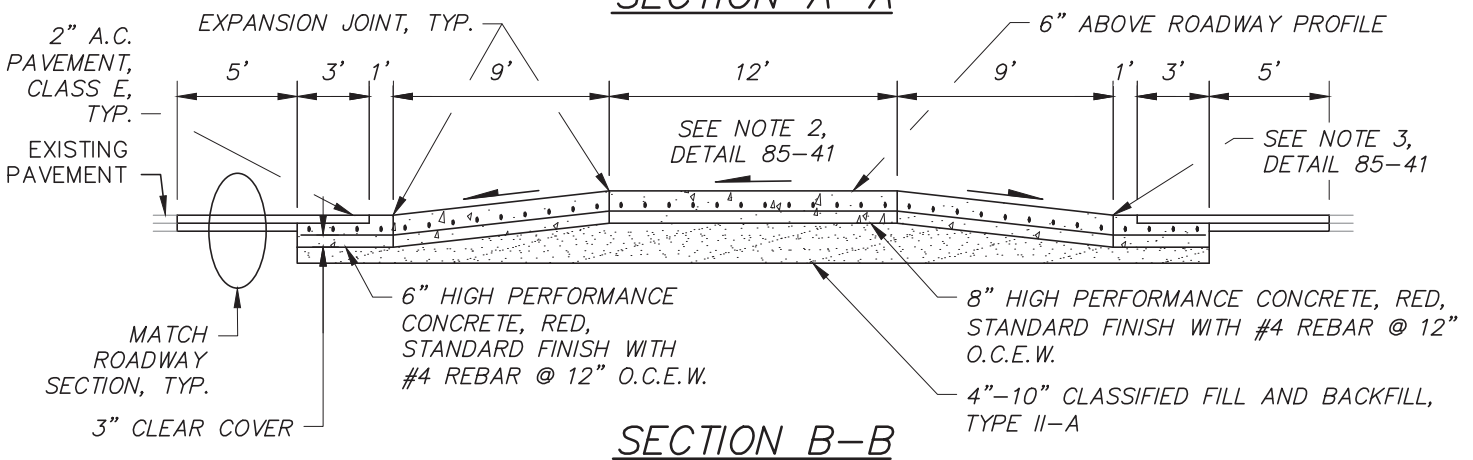
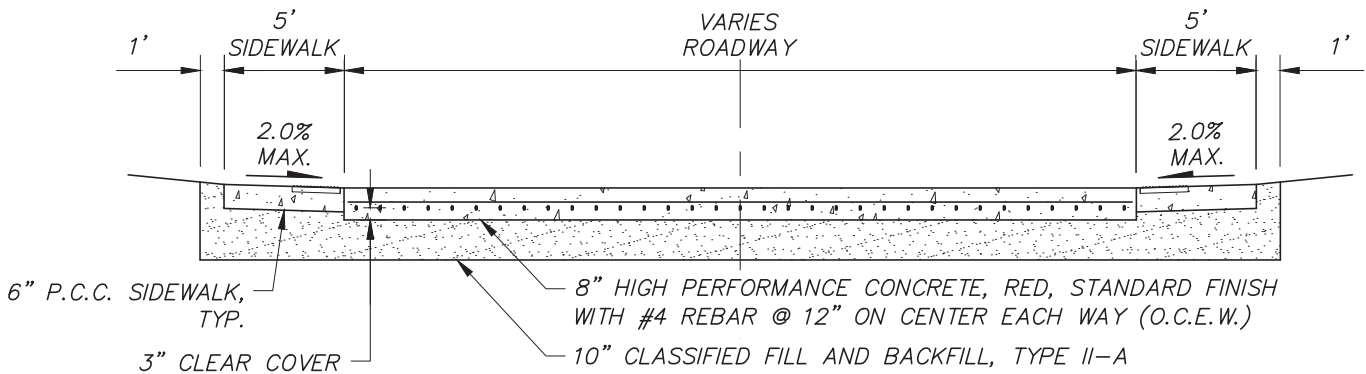
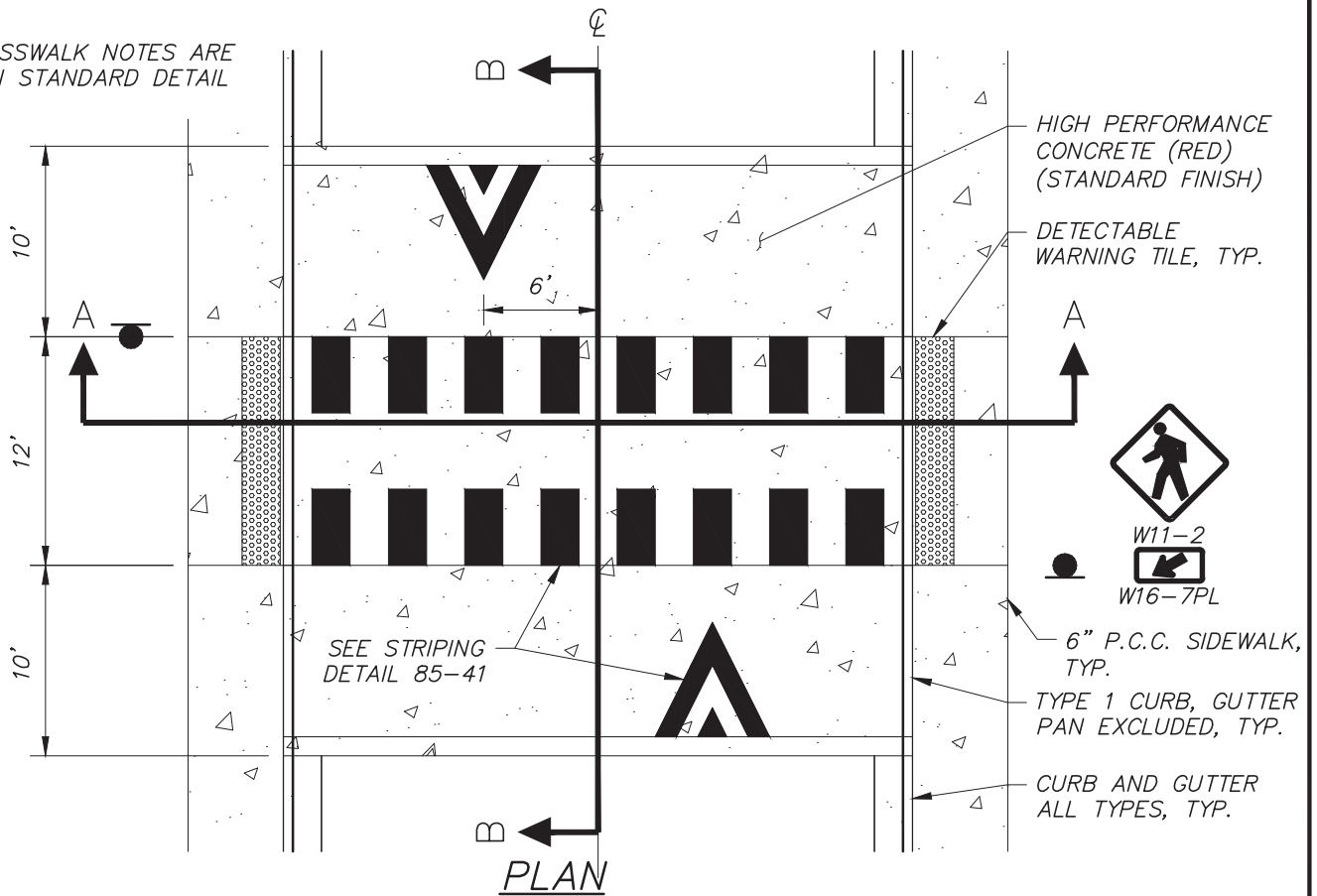

SCALE:
N.T.S.

APPROVED:

REVISED:
2/24

TYPE A RAISED CROSSWALK

SECTION #
DIV 85

DETAIL #
85-40

GENERAL NOTES:

1. RAISED CROSSWALKS SHALL BE CONSTRUCTED PRIOR TO PLACEMENT OF TOP LIFT OF PAVEMENT.
2. RAISED CROSSWALK SLOPES SHALL BE:
 - A. 1.5% MAXIMUM AT YIELD OR STOP CONTROLLED INTERSECTIONS;
 - B. 4.5% MAXIMUM AT UNCONTROLLED INTERSECTIONS;
 - C. MATCH EXISTING STREET GRADE AT MID-BLOCK LOCATIONS.
3. CHANGE IN GRADE BETWEEN RAMP RUNS AND ROADWAY SHALL BE:
 - A. 5.5% FOR RAISED CROSSWALKS FOR ROADS \leq 25 MPH WITH A $\pm 0.5\%$ TOLERANCE;
 - B. 4.5% FOR RAISED CROSSWALKS FOR ROADS $>$ 25 MPH $\pm 0.5\%$ TOLERANCE.
4. RAISED CROSSWALKS SHALL NOT BE PLACED ON ROADS WITH GRADES GREATER THAN 8.0%.
5. RAISED CROSSWALK STRIPING SHALL BE 250 MIL INLAID METHYL METHACRYLATE.
6. PLACE ARROW SYMBOLS IN CENTER OF LANE. VERIFY WITH THE ENGINEER PRIOR TO PLACEMENT.
7. RAISED CROSSWALKS FOR ROADS $>$ 25 MPH SHALL ONLY BE CONSTRUCTED WITH THE APPROVAL OF THE MUNICIPAL ENGINEER AND/OR THE TRAFFIC ENGINEER.

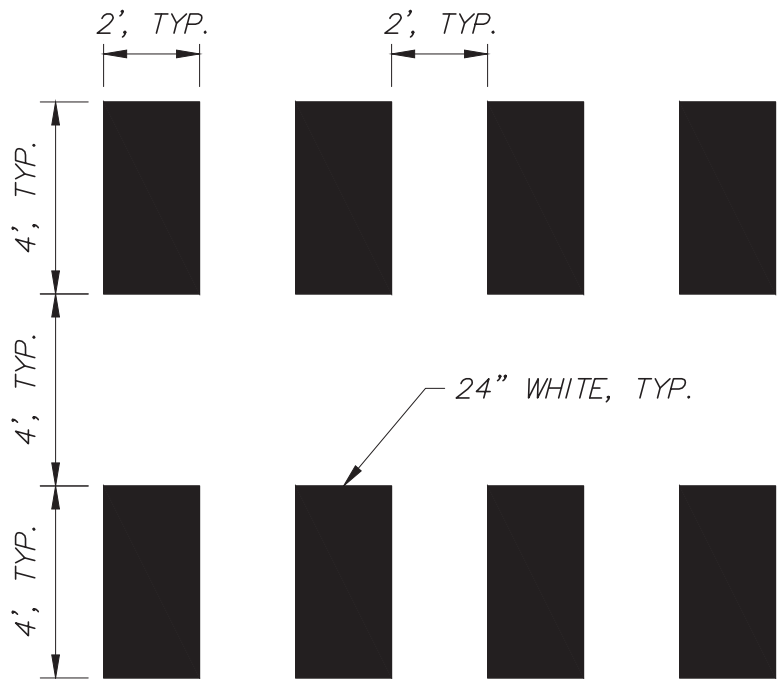

CROSSWALK STRIPING DETAIL

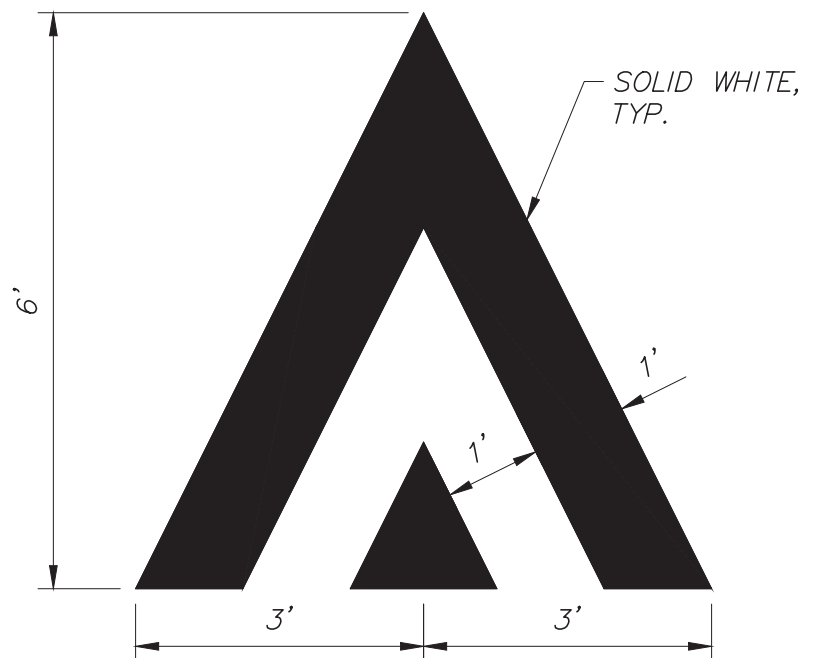

CROSSWALK MARKING DETAIL

 <p>MUNICIPALITY OF ANCHORAGE</p>	<p>SCALE: N.T.S.</p> <p>APPROVED:</p> <p>REVISED: 2/24</p>	<p>RAISED CROSSWALK STRIPING AND NOTES</p>	<p>SECTION # DIV 85</p> <p>DETAIL # 85-41</p>
--	--	---	---

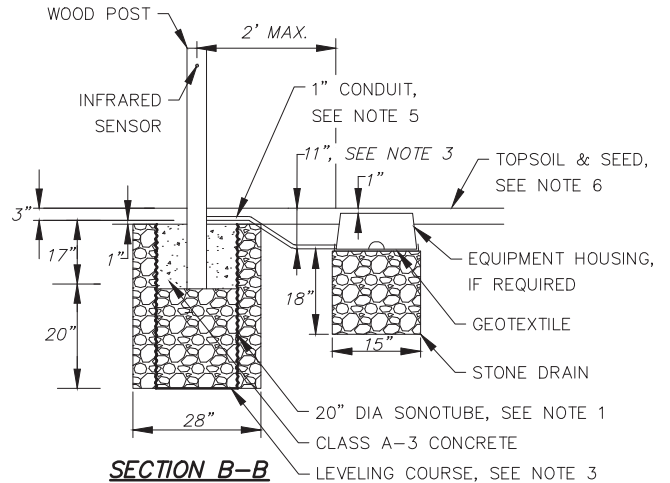
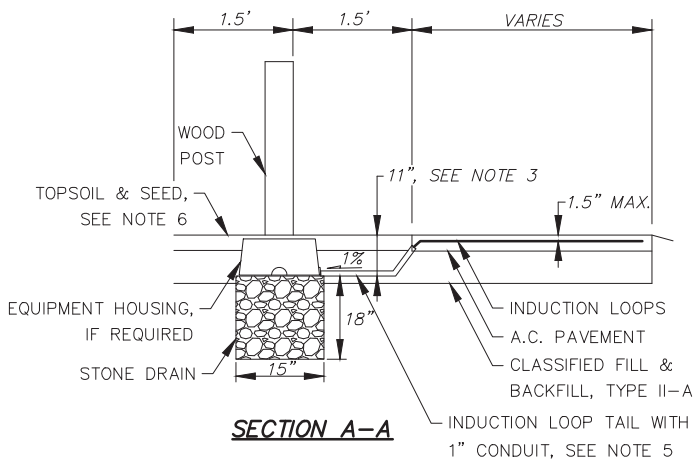
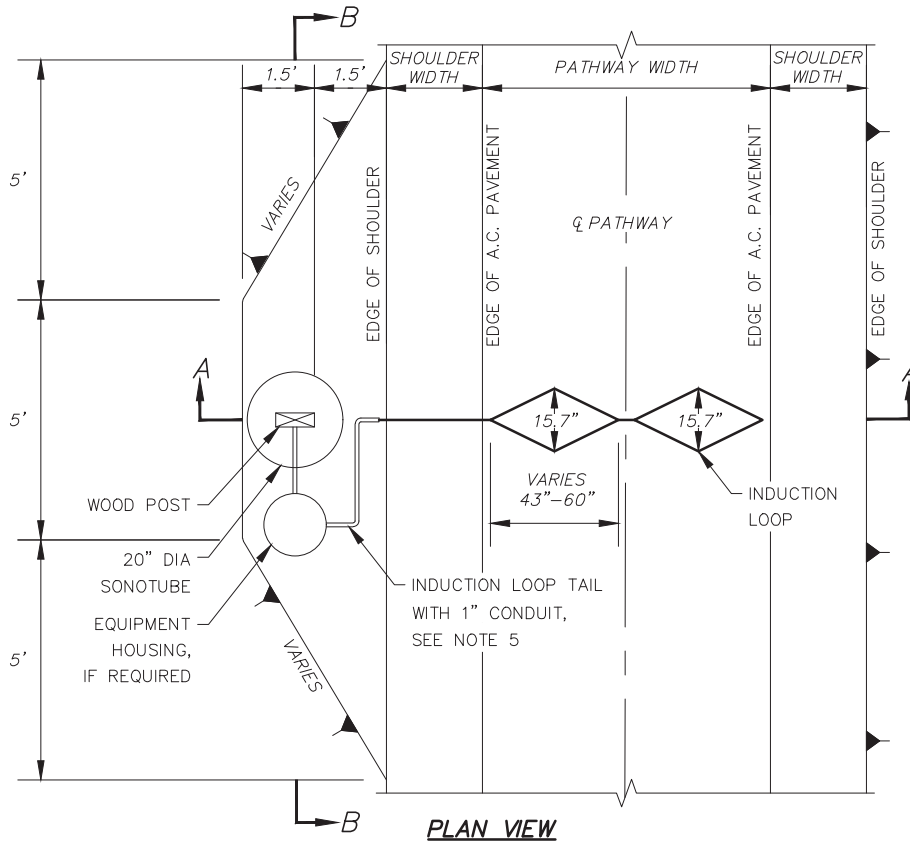

MULTI-MODAL PATHWAY COUNTER NOTES:

1. TOP OF CONCRETE SHALL BE 1 INCH BELOW INDUCTION LOOP TAIL INTAKE.
2. IF GROUNDWATER IS ENCOUNTERED, RAISE DEPTH OF INDUCTION LOOP TAIL. CONTACT ENGINEER.
3. SURROUND SONOTUBE WITH LEVELING COURSE FOR STABILITY. FILL SONOTUBE WITH LEVELING COURSE TO CORRECT CLEARANCES. COMPACT BY HAND TAMPING.
4. ENSURE POST IS PLUMB TO THE GROUND, WITH THE INFRARED SENSOR PERPENDICULAR TO THE PATHWAY. A.C. PAVEMENT SHALL BE AT FINISH GRADE.
5. EQUIPMENT HOUSING, IF REQUIRED, SHALL INCLUDE INDUCTION LOOP SENSOR, LOGGER, COMMUNICATIONS, AND BATTERY. IF ALL COMPONENTS ARE ENCASED IN POST, RUN INDUCTION TAIL DIRECTLY FROM INDUCTION LOOPS TO POST.
6. COVER EQUIPMENT HOUSING WITH 1 INCH OF TOPSOIL & SEED.

REVISION: 2024 M.A.S.S. UPDATE



SCALE:
N.T.S.
APPROVED:
REVISD:
2/24

MULTI-MODAL PATHWAY COUNTER

SECTION #
85.12

DETAIL #
85-42

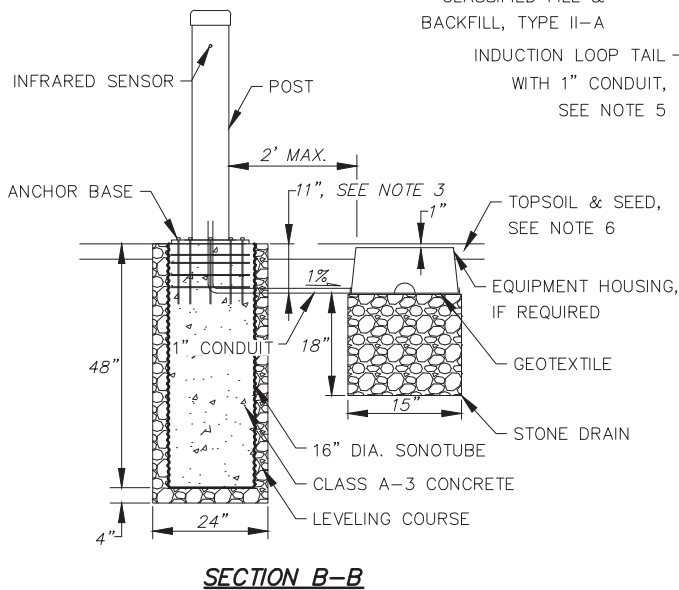
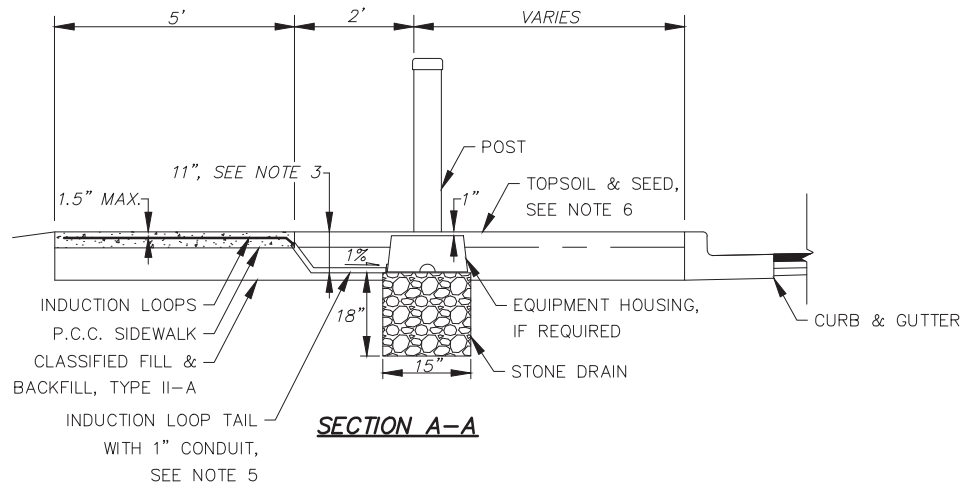
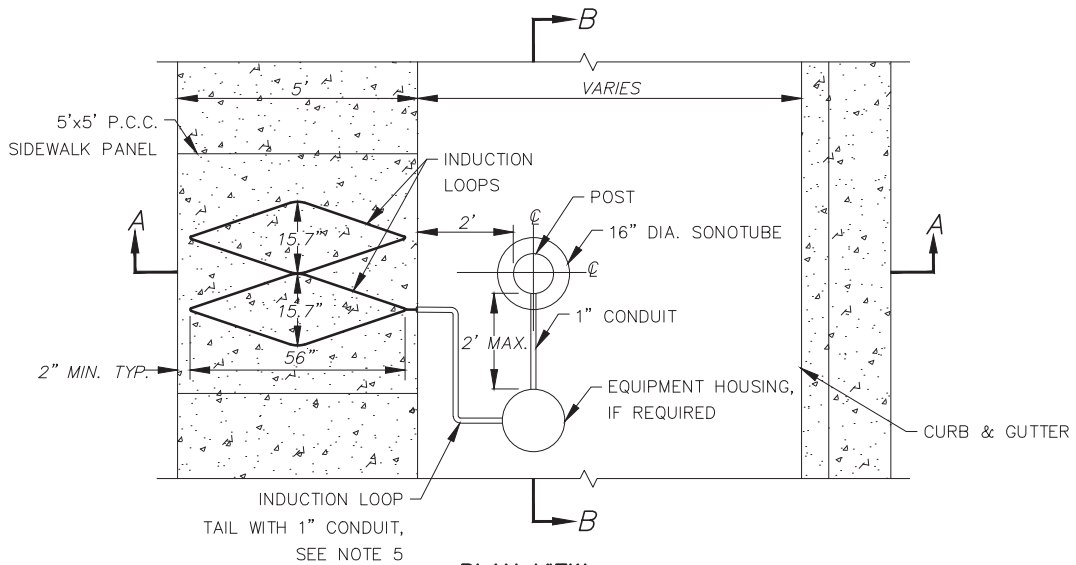

MULTI-MODAL SIDEWALK COUNTER NOTES:

1. INDUCTION LOOPS SHALL BE LOCATED WITHIN 1 P.C.C. SIDEWALK PANEL.
2. SURROUND SONOTUBE WITH LEVELING COURSE FOR STABILITY.
3. IF GROUNDWATER IS ENCOUNTERED, RAISE DEPTH OF INDUCTION LOOP TAIL. CONTACT ENGINEER.
4. ENSURE POST IS PLUMB TO THE GROUND, WITH THE INFRARED SENSOR PERPENDICULAR TO THE SIDEWALK. CONCRETE SURFACE SHALL BE AT FINISHED GRADE.
5. EQUIPMENT HOUSING, IF REQUIRED, SHALL INCLUDE INDUCTION LOOP SENSOR, LOGGER, COMMUNICATIONS, AND BATTERY. IF ALL COMPONENTS ARE ENCASED IN POST, RUN INDUCTION LOOP TAIL DIRECTLY FROM INDUCTION LOOPS TO POST.
6. COVER EQUIPMENT HOUSING WITH 1 INCH OF TOPSOIL & SEED.

REVISION: 2024 M.A.S.S. UPDATE

MUNICIPALITY



OF ANCHORAGE

SCALE:
N.T.S.

APPROVED:

REVISED:
2/24

MULTI-MODAL SIDEWALK COUNTER

SECTION #
85.12

DETAIL #
85-43