

**MUNICIPALITY OF ANCHORAGE
STANDARD SPECIFICATIONS**

**DIVISION 60
WATER SYSTEMS**

**STANDARD CONSTRUCTION SPECIFICATIONS
FOR WATER SYSTEMS
DIVISION 60
INDEX**

SECTION 60.01	GENERAL	1
Article 1.1	Scope of Work.....	1
Article 1.2	Applicable Standards	1
Article 1.3	Survey	4
Article 1.4	Definitions	5
Article 1.5	Payment - General	5
SECTION 60.02	FURNISH AND INSTALL PIPE	6
Article 2.1	General	6
Article 2.2	Submittals	6
Article 2.3	Material	6
Article 2.4	Construction	12
Article 2.5	Flushing and Testing.....	19
Article 2.6	Measurement	24
Article 2.7	Basis of Payment	25
SECTION 60.03	FURNISH AND INSTALL VALVES	27
Article 3.1	General	27
Article 3.2	Submittals	27
Article 3.3	Material	27
Article 3.4	Construction	29
Article 3.5	Measurement	30
Article 3.6	Basis of Payment	31
SECTION 60.04	FURNISH AND INSTALL FIRE HYDRANTS	32
Article 4.1	General	32
Article 4.2	Submittals	32
Article 4.3	Materials	32
Article 4.4	Construction	33
Article 4.5	Measurement	34
Article 4.6	Basis of Payment	34
SECTION 60.05	WATER SERVICE LINES	36
Article 5.1	General	36
Article 5.2	Submittals	36
Article 5.3	Material	36
Article 5.4	Construction	37
Article 5.5	Measurement	40
Article 5.6	Basis of Payment	40
SECTION 60.06	FURNISH AND INSTALL GALVANIC ANODES	42
Article 6.1	General	42
Article 6.2	Submittals	42
Article 6.3	Materials	42
Article 6.4	Construction	42

Article 6.5	Measurement	43
Article 6.6	Basis of Payment	44
SECTION 60.07	TEMPORARY WATER SYSTEMS	45
Article 7.1	General	45
Article 7.2	Submittal	45
Article 7.3	Material	46
Article 7.4	Construction	47
Article 7.5	Measurement	48
Article 7.6	Basis of Payment	48
SECTION 60.08	DECOMMISSION WATER SYSTEM AND COMPONENTS	50
Article 8.1	General	50
Article 8.2	Submittals	50
Article 8.3	Material	50
Article 8.4	Construction	50
Article 8.5	Measurement	53
Article 8.6	Basis of Payment	54

**STANDARD CONSTRUCTION SPECIFICATIONS
FOR WATER SYSTEMS
DIVISION 60**

SECTION 60.01 GENERAL

This section is to be applied and used for all Sections in Division 60.

Article 1.1 Scope of Work

The Work covered by these Specifications consists of providing all plant, labor, equipment, supplies, material, permitting, transportation, handling and storage, and performing all operations necessary to complete the construction of all water facilities that will be distributing water by the Utility Company having jurisdiction.

Requirements for earthwork, concrete, landscaping and other associated work items are found in other Divisions and are complimentary to this Division.

The Contractor is to locate and treat utilities in compliance with Division 10, Section 10.04, Article 4.17 – Utilities.

The Contractor, by providing a Bid Proposal and entering into a Contract with the Owner has found that the access, easements, rights-of-way, and other work areas designated in the Drawings are adequate to perform the Work and/or the Contractor has or will secure additional work areas to complete the Work. Furthermore, all costs associated with the Contractor secured work areas is to be included in the Bid Proposal.

Additional areas secured by the Contractor from parties not associated with the Contract are to be memorialized in the form of a right of entry agreement between the Contractor and party having authority to enter an agreement for the work area. A copy of the right of entry agreement is to be provided to the Owner. The right of entry agreement is to extend the indemnification requirements found in the Contract to Contractor obtained work areas.

The Contractor is to restore the area of Work to preconstruction conditions or better except where shown different in the Contract Documents. Where preconstruction conditions cannot be obtained such as items that require growth to obtain height, thickness and other prized attributes then they are to be replaced with standard nursery stock plant material of the same species and type that will grow back to preconstruction conditions and maintained in accordance with the Contract Documents. The Contractor is to secure written approval by the Engineer for replacement material differs from the Contract requirements.

Where the requirements in this division call out for an Engineer and there is no one assigned the duties of the Engineer, then the Utility Company is to be consulted for direction for items that require an Engineer or Inspector.

Article 1.2 Applicable Standards

The most recent revisions of the following standards are made a part of these Specifications:

AASHTO M306 Standard Specification for Drainage, Sewer, Utility, and Related Castings, Single User Digital Publication

ASTM A126	Specification for Gray Iron Castings for Valves, Flanges and Pipe Fittings
ASTM B88	Specification for Seamless Copper Water Tubing
ASTM D256	Test Methods for D-C Resistance of Plastics and Electrical Insulating Materials
ASTM D3035	Specification for Polyethylene (PE) Plastic Pipe (SDR-PR) Based on Controlled Outside Diameter
ASTM D3261	Specification for Butt Heat Fusion Polyethylene (PE) Plastic Fittings for Polyethylene (PE) Plastic Pipe and Tubing
ASTM D3350	Specification for Polyethylene Plastic Pipe and Fittings Materials
ASTM F1674	Standard Test Method for Joint Restraint Products for Use with PVC Pipe.
ASTM F4777	Standard Specification for Elastomeric Seals (Gaskets) for Joining Plastic Pipe
AASHTO M45	Sand for Cement Mortar
AWWA A100	Water Wells
AWWA C104/ ANSI A21.4	Cement-Mortar Lining for Ductile-Iron Pipe and Fittings for Water
AWWA C105/ ANSI A21.5	Polyethylene Encasement for Ductile Iron Piping for Water and Other Liquids
AWWA C110/ ANSI A21.10	Ductile-Iron and Gray-Iron Fittings, 3 in. through 48 in., for Water and Other Liquids
AWWA C111/ ANSI A21.11	Rubber-Gasket Joints for Ductile-Iron and Gray-Iron Pressure Pipe and Fittings
AWWA C115/ ANSI A21.15	Flanged Ductile-Iron Pipe with Threaded Flanges
AWWA C116/ ANSI A21.16	Protective Fusion-Bonded Epoxy Coatings for the Interior and Exterior Surfaces of Ductile-Iron and Gray-Iron Fittings for Water Supply Service
AWWA C150/ ANSI A21.50	Thickness Design of Ductile-Iron Pipe
AWWA C151/ ANSI A21.51	Ductile-Iron Pipe, Centrifugally Cast in Metal Molds or Sand-Lined Molds, for Water or Other Liquids
AWWA C153/ ANSI A21.53- 84:	Ductile-Iron Compact Fittings
AWWA C213	Fusion-Bonded Epoxy Coating for the Interior and Exterior of Steel Water Pipelines

AWWA C303	Reinforced Concrete Pressure Pipe, Steel Cylinder Type, Pre-Tensioned, for Water and Other Liquids
AWWA C500	Gate Valves for Water and Sewerage Systems
ANSI/ AWWA C502	Dry-Barrel Fire Hydrants
ANSI/ AWWA C504	Rubber-Seated Butterfly Valves
AWWA C509	Resilient-Seated Gate Valves for Water Supply Service
AWWA C515	Reduced-Wall, Resilient-Seated Gate Valves for Water Supply Service
ANSI/ AWWA C600	Installation of Ductile-Iron Water Mains and Their Appurtenances
ANSI/ AWWA-C605	Underground Installation of Polyvinyl Chloride (PVC) Pressure Pipe and Fittings for water.
AWWA C651	Disinfecting Water Mains
ANSI/ AWWA C652	Disinfection of Water Storage Facilities
ANSI/ AWWA C800	Underground Service Line Valves and Fittings
AWWA C901	Standard for Polyethylene (PE) Pressure Pipe and Tubing, 1/2 in. through 3 in., for Water Service
AWWA C900	Polyvinyl Chloride (PVC) Pressure Pipe and Fabricated Fittings, 4 inch through 12 inch for Water Transmission and Distribution
AWWA C905	Polyvinyl Chloride (PVC) Pressure Pipe and Fabricated Fittings, 14 inch through 48 inch for Water Transmission and Distribution
ANSI/ AWWA D100	Welded Steel Tanks for Water Storage
ANSI/ AWWA D102	Coating Steel Water-Storage Tanks
SSPC-SP	Steel Structures Painting Council Surface Preparation Specifications
SSPC-PA	Steel Structures Painting Council Paint Application Specifications
NSF (Standard 61)	Drinking Water System Components – Health Effects
UBC	Uniform Building Code, latest edition adopted by MOA and current local amendments
IBC	International Building Code, latest edition adopted by MOA and current local amendments

UFC	Uniform Fire Code, latest edition adopted by MOA and current local amendments
IFC	International Fire Code, latest edition adopted by MOA and current local amendments
ISO 8179-1	Ductile Iron Pipes-External Zinc-Based Coating – Part1: Metallic Zinc with Finishing Layer
UMC	Uniform Mechanical Code, latest edition adopted by MOA and current local amendments
IMC	International Mechanical Code, latest edition adopted by MOA and current local amendments
UPC	Uniform Plumbing Code, latest edition adopted by MOA and current local amendments
NEC	National Electrical Code, latest edition adopted by MOA and current local amendments
NFPA	Other National Fire Protection Association Standards, latest edition adopted by MOA and current local amendments
AWG	America Wire Gauge
HMWPE	High Molecular Weight Polyethylene
NACE	National Association of Corrosion Engineers

Article 1.3 Survey

Survey must be performed by the Contractor per Division 65 - Construction Survey. Survey is to be incidental to items under construction unless a pay item for Construction Survey Measurement is provided. The Contractor is to as-built and record at a minimum the following items based on the design survey horizontal and vertical control when provided or else the use local horizontal and vertical control when not provided by a design survey:

- Each pipe bottom and length of pipe segment
- Manholes, inverts, cleanouts
- Fire hydrants, valves, keyboxes, tees, fittings, restraint, pipe to pipe connections specialized fittings
- Other buried utility conduits, vaults, utilitdors, wires, manholes, catch basins
- Other utility surface features such as pedestals, junction boxes, power poles, light poles

Before working in developed areas, the Contractor is to take photographs and video documenting existing conditions. Photographs and video are to include major construction areas and their boundaries as well as a zone fifty feet (50') outside the furthest anticipated impact. Photo and video documentation is incidental to the Work.

Article 1.4 Definitions

The definitions provided within this Article are supplemental to definitions provided in Division 10 and are to govern in the interpretation of all disputes. Industry standard definitions are to apply if a definition is not provided. Where a term, word or phrase has varying meanings, the Engineer will have final say on the interpretation.

Water Service Connection – water pipe and associated apparatuses from the point of connection to a water main to the terminus of the Utility Company maintenance responsibility, usually the property line or Utility Company easement. The terminus of the water service connection is usually defined by a valve.

Water Service Extension – typically it is water pipe and associated apparatuses on a parcel of land that begins where the Water Service Connection ends.

Service – connection, extension, and/or building piping from the Utility Company water distribution system.

Main Line – Water pipe servicing multiple customers within an easement owned by the Utility Company or within a public right of way.

Water Distribution System – Anything that is used to distribute potable water.

Fire Line – A portion of the water service with no additional branches that has the primary purpose of providing fire protection inside of a building. Typically a service that originates at a mainline or at a valve downstream of a fire hydrant tee continuing directly into a building with a sprinkler fire suppression system. Water extensions that are four inches (4”) and larger will be considered a fire line for the purpose of pressure testing.

Sewer – Non-domestic and domestic wastewater as defined in 18 AAC 72.990.

Article 1.5 Payment - General

No separate payment will be made to the Contractor for Contractor obtained work areas or the restoration thereof.

Restoration Work not covered by bid items is to be considered incidental and no separate payment will be made. Restoration completed in Contractor secured areas is incidental to the contract.

Payment for all Work included in this Division will be paid for in accordance with Division 10, Section 10.07 - Measurement and Payment, and will include full payment for all Work described.

SECTION 60.02 FURNISH AND INSTALL PIPE

Article 2.1 General

The Work under this Section consists of performing all Work required for furnishing and installing an operational piping system in a workman like manner meeting applicable standards. The Contractor shall install piping systems as specified within these Contract Documents, the manufacturer's recommendations, the American Water Works Association (AWWA) standards, the Utility Company's most current Design and Construction Practices Manual (DCPM), per the Engineer's written directives and in conformity with the lines and grades as shown on the Drawings. Where the previously stated requirements are in conflict the more stringent requirement is to govern.

Article 2.2 Submittals

Submittals are to be provided to the Engineer for review and acceptance as stated in Division 10, Section 10.05, Article 5.6 – Product Data. The Contractor is to clearly demarcate items to be incorporated into the Work. Submittals for pipe and fittings should at least the following items:

- Pipe
- Fittings
- Detectable underground warning tape
- Trace and continuity wire
- Contractor thrust restraint calculations
- Polyethylene baggies and sheeting
- Coatings
 - Pipe layout plan
 - Storage Temperature
 - Surface preparation requirements
 - Coating repair plan
 - Applicator resumes
 - Application equipment
 - mixing and application time of coating
 - Curing time
- Flushing and testing plan
- Survey Personnel qualifications

Article 2.3 Material

A. Ductile Iron Pipe

Ductile iron pipe is to be cement mortar lined, conforms to the requirements of AWWA C151, and has a minimum pipe wall thickness meeting Class 52 requirements. The cement mortar lining is to conform to the requirements of AWWA C104/ANSI A24.1. At least 10% of the pipe delivered is to be gauged full length of the pipe and marked as such.

B. Zinc Coated Ductile Iron Pipe (qualifies as tightly bonded)

Zinc Coated Ductile Iron Pipe is to be ductile iron pipe meeting item A of this Article with a metallic zinc coat and a bituminous finish layer in accordance with ISO 8179-1, with the minimum mass of zinc being 150 grams per square meter and a mean mas of 200 grams per square meter of 99.99% pure metallic zinc.

C. Polyurethane Coated Ductile Iron Pipe (qualifies as tightly bonded)

Polyurethane Coated Ductile Iron Pipe is to be ductile iron pipe meeting item A of this Article that has been prepared to receive a solventless elastomeric aromatic polyurethane, chemical cure, ASTM Type V coating that is compatible with in-situ soil conditions. Surface preparation is to be in accordance with the coating manufacturer's instructions.

The polyurethane coating is to have balanced viscosities in their liquid state that does not require agitation during use.

Coating material is to be Lifelast Durashield 310 or as approved by the Engineer and Utility Company.

All coating material is to remain in manufacturer's unopened containers and stored per the manufacturer's recommendations until required for use. Each container is to have the following items plainly visible: name of manufacturer, product, date of manufacture, shelf life, and batch number.

Coating material that has exceeded manufacturer's recommended shelf life or pot life, has been frozen or over heated, is stored in damaged containers, has broken or leaking seals or has jelled or otherwise deteriorated during storage must not be used.

Shelf life, temperature, and humidity limitations for each of the coating system components shall be maintained in strict accordance with coating manufacturer's recommendations during shipping, storage and application.

Thinning shall not exceed limitations established by manufacturer. Type of thinner shall comply with manufacturer's instructions.

D. Epoxy Coated Ductile Iron Pipe (qualifies as tightly bonded)

Epoxy Coated Ductile Iron Pipe is to be ductile iron pipe meeting item A of this article with a high build and high solids epoxy coating system.

Inspect, clean and blast surfaces in accordance with SSPC SP-1 or NAPF 500-03-01 and NAPF 500-03-04. Solvent clean as necessary to remove any deposits of asphalt paint, oil, grease, soil, drawing and cutting compounds and other soluble contaminants prior to abrasive blasting.

The following coating system, or Engineer approved equal, shall be used:

<u>Coating Materials</u>	<u>Coating Thickness (DFT)</u>	
	<u>Minimum (mils)</u>	<u>Maximum (mils)</u>
Sherwin Williams Fast Clad ER Epoxy 1st Coat	18	20

<u>Coating Materials</u>	<u>Coating Thickness (DFT)</u>	
	<u>Minimum (mils)</u>	<u>Maximum (mils)</u>
Sherwin Williams Fast Clad ER Epoxy 2nd Coat	18	20
Sherwin Williams Fast Clad ER Epoxy 3rd Coat	18	20
Total Dry Film Thickness (DFT)	54	60

All Manufacturer's instructions and safety precautions shall be followed.

Deliver all coating materials to the job site in their original, unopened containers. Clearly mark packaging with the coating Manufacturer's name, product name, manufacture date, shelf life, batch number and color.

Apply all coatings in accordance with SSPC PA-1, this procedure and the coating Manufacturer's recommendations. If a conflict exists, contact the Engineer for the determination of which is applicable.

Coats must not be applied whenever the relative humidity exceeds eighty-five percent (85%), or whenever the surface temperature is less than five degrees (5°) Fahrenheit above the dew point of the ambient air. The temperature of the surface shall not be less than sixty degrees (60°) Fahrenheit during application. Ambient and pipe temperatures shall be within the range recommended by the coating Manufacturer.

Coatings shall be applied to dust free surfaces. Test the surfaces by applying a strip of clear adhesive tape to the surface and rub onto the surface with a finger. When removed, the tape should show little or no dust, blast abrasive, or other contaminants. If found contaminated, clean by compressed air or vacuum cleaning and retest.

E. Polyvinyl Chloride (PVC) Pipe

Four inch (4") through twelve inch (12") Polyvinyl Chloride Pipe is to conform to the requirements of AWWA C900, have a dimensional ratio (DR) of 18.

Fourteen inch (14") through sixteen inch (16") Polyvinyl Chloride Pipe must conform to the requirements of AWWA C905, have a DR of 18. PVC pipe larger than sixteen inches (16") in diameter requires approval from the Utility Company's Engineering Director for use.

All PVC pipe is to be blue in color. PVC water main and service piping must be installed with an over insertion prevention device equal to EBAA Iron Mega Stop or the Cert-Lok bi-directionally restraint system.

F. High Density Polyethylene Pipe

High Density Polyethylene Pipe (HDPE) and fittings are to be manufactured in accordance with AWWA C906 with the additional stipulation that the HDPE is to be manufactured from PE4710 polyethylene compounds that meet or exceed ASTM D3350 Cell Classification 445574. HDPE pipe and fitting material compound is to

contain color and ultraviolet (UV) stabilizer meeting or exceeding the requirements of Code C per ASTM D3350. Electrofusion fittings will not be allowed. All fittings are to have pressure class ratings not less than the pressure class rating of the pipe to which they are joined.

G. Coated Copper Pipe

Coated copper pipe must be soft-drawn Type K, seamless, annealed copper pipe suitable for use as underground service water connections for general plumbing purposes and ASTM B88 compliant with an approved coating system.

Approved coatings include factory applied minimum twenty-six (26) mil thick polyethylene or a field applied coating.

H. Field Applied Coatings

Where a coating is required, field applied coatings may be used for repair of, in conjunction with or substitution for other coatings. Field applied coatings are to be denso wrap system, trenton wax tape system or viscotag viscowrap system. The term "system" requires the use of more than one product from the specified manufacturer to be used in concert to seal the pipe from corrosive and/or potentially contaminated environments and water. At a minimum, the system is to fully encapsulate the piping and fittings, fill voids/gaps and adhere to the pipe. The coating system must not interfere with the operation of moving parts.

I. Fittings and Gaskets

Iron fittings are to have exterior and interior surfaces coated with fusion bonded epoxy in accordance with AWWA C116/A21.13-09, with the only exception being for PVC overstab bell protection devices which do not need to be coated.

Romac 501 couplers are not allowed on water lines.

Unless otherwise indicated on the Drawings, rubber gaskets for iron pipe is to conform to AWWA C111 and rubber gaskets for PVC pipe joints are to conform to ASTM F477.

Ductile and cast iron fittings are to be a minimum of two hundred fifty pound (250#) pressure rating, flange, mechanical joint or bell, lined or unlined. Fittings must conform to the requirements of AWWA C110/ANSI A21.10 or C153 A21.53-06.

Fittings with nut and bolts are to utilize carbon steel or stainless steel nuts and bolts. Fittings with carbon steel bolts and nuts must conform to the dimensional and material standards as outlined in AWWA C111 and C115 and be factory-coated with a blue fluoropolymer coating system. Fittings with stainless steel bolts and nuts must conform to the dimensional standards as outlined in AWWA C111 and C115 and the material standards in ASTM F593 and F594 with a minimum tensile strength of 75,000psi. Bolts and nuts must have imprinted markings indicating the material and grade of the metal used in fabrication. Where bolts and nuts for fittings cannot be covered by the above references then the Contractor must submit a deviation request to the Engineer and Utility Company.

Fittings used with copper pipe are to be rated high pressure (150 psi) per AWWA C800. Brass components in contact with potable water are to comply with Public

Law 111-380 (No Lead Rule). Fittings are to accept flared copper pipe or have NPT threads for threading into other fittings. Buried Brass fittings are to be field coated in the same manner as coated copper pipe.

J. Thrust Restraint System

All thrust restraint system components are to be FM Global approved for the intended use or be UL listed. The surfaces of ferrous components are to have a fusion bonded epoxy coating in accordance with AWWA C116/A21.13-09.

Thrust restraint systems are required where specified on the Drawings and at fittings, valves and piping deflection points. The length of required restraint is dependent upon the system characteristics (i.e. soils, depth of cover, pipe size, etc...) in which it is installed. The Contractor must submit restraint length computations to the Engineer. Where the Contractor provided computations and the length shown in the computations do not match the Drawings, then the greater restraint length takes precedent. When the Drawings do not show restraint length at fittings, valves and piping deflection points and the Contractor does not provide calculations; then the entire length of pipe is to be restrained.

Where the Contractor proposes to use non-certified (i.e. FM Global, Underwriter Laboratories, ASTM, AWWA) thrust restrain systems they are to field demonstrate to the Engineer and the Utility Company the installation and/or construction of each new restrained joint or restraining system. Field demonstration must show the performance and sustainability of the restraint system to such a degree as to be equal to FM Global or applicable ASTM requirements. The Engineer and the Utility Company will make the final determination of the acceptability of Contractor proposed non-certified thrust restraint. Each approval will be project specific and re-testing is required for each subsequent project proposed use. All costs for approval or rejection of non-certified thrust restraint and restraint systems are to be borne by the Contractor.

1. Additional Requirements for Ductile Iron Pipe (with or without coatings)

Tie back rods and/or tie back rod and shackle assemblies, along with thrust blocks will not be acceptable thrust restraining system.

Metallic fittings when not bonded and made amalgams to the pipe cathodic protection system requires a separate corrosion protection system.

2. Additional Requirements for Polyvinyl Chloride Pipe

Thrust restrain systems are to meet the standards of ASTM F1674.

Chemical bonding will not be allowed. Metallic fittings require a separate corrosion protection system.

3. Additional Requirements for High Density Polyethylene Pipe

Thrust restraint systems may be heat fusion bonding, flange fittings fusion bonded with metallic backer rings, alpha romac coupler or equal and other couplers with pipe stiffeners.

Metallic fittings require a separate corrosion protection system. Electro-fusion couplings are not allowed on Utility Company maintained pipe.

4. Additional Requirements for Copper Pipe

Copper pipe thrust restraint systems are the use of flared fittings and silver solder brazed joints.

K. Pipe Material Limitations

Copper is the only pipe material allowed on small diameter (less than 4") water service connections. Copper pipe for direct bury is limited in size from 1" to 2" in nominal diameter. Copper pipe is to be coated type K seamless copper tubing. Factory coating is to be a minimum 26 Mil thick blue color polyethylene jacket. Field coating may be applied to areas of factory coating damage or pipe that does not have an option to come coated from a factory.

Four inch (4") and larger pipe are to have standard jointing consisting of bell to spigot with a gasket appropriate for the service environment. Where joints in copper pipe are needed, they are to be sealed with silver brazing.

L. Trace Wire

Trace wire for water lines is to be #10 AWG high-strength copper clad steel with a 30-mil HDPE insulation jacket (color blue) and have a 600-pound average tensile break load. Tracer wire is to be manufactured by Copperhead Industries or an approved equal.

Grounding rods are to be a minimum of twenty four inches (24") in length and copper clad.

The direct burial grounding clamps are to be EK17 as manufactured by Erico or approved equal.

All splice connections are to be constructed using 3M DBR watertight connectors, or approved equal.

DryConn Waterproof Direct Bury Lugs as manufactured by King Innovation, or approved equal, is to be used to splice into the main line tracer wire.

M. Thaw and Continuity Strap Wire

The wire shall be insulated No. 2 AWG stranded copper conductor rated for 600V. Insulation shall be HMWPE or approved for use in buried low temperature service. Split bolts or mechanical bolt connection of the wires will not be allowed.

N. Detectable Warning Tape

Detectable warning tape must not be less than five (5) mil, foil backed, six inches (6") wide vinyl tape, colored blue, with "Caution Buried Water Line Below" continuously printed in black along the tape length.

O. Polyethylene Encasement

Polyethylene encasement material for pipe is to be eight (8) mils thick and conform to AWWA C105. Polyethylene encasement is to include a VBio film system incorporating corrosion control additives and MIC control additives as provided by US Pipe or approved equal.

Article 2.4 Construction

A Water Flow Interruptions

All planned interruptions require the Contractor to notify the Utility Company, Engineer, the Municipality of Anchorage Fire Department (AFD), property owners, property managers and residents a minimum of seventy-two (72) hours and a maximum of one-hundred forty-four (144) hours in advance of the interruption.

Properties with fire sprinklers require a minimum of three non-holiday and non-weekend days of notice to allow property managers time to mitigate impacts to fire suppression systems.

Each interruption requires a separate notification. Interruptions not started within the planned interruption period require a new notice and notifying period. Along with notice requirements, planned interruptions may not affect any portion of a previous interruption until a minimum of forty eight (48) hours has passed the previous interruption.

The water service outage area is water system infrastructure and project dependent. Upon notifying the Utility Company of a planned interruption, the Contractor will allow the Utility Company up to fourteen (14) working days to clean and operate valves, operate hydrants and complete test shutdowns to establish the limits of the shutdown area. Once the shutdown area has been defined, the Utility Company will provide the Contractor a map or list of properties indicating the anticipated shutdown area.

Shutdown does not implicitly mean shut off and the Contractor is to plan for up to two hundred gallons per minute (200 gpm) of water from the water system to enter the work area after the pipes have been depressurized. The Contractor is to mitigate impacts to the system and implement energy control measures.

The Contractor is to notify the Municipality of Anchorage Department of Health and Human Services where an interruption impacts or has the potential to impact a business establishment that provides food or health care services. Critical health care services as shown on the Drawings or called out in the special provisions are to be provided temporary water at all times.

It shall be the Contractor's responsibility to coordinate "turn-off" and "turn-on" with the Engineer and the Utility Company. The Contractor cannot operate the Utility Company's water system to achieve a water interruption.

Where and when the Work is reasonably anticipated to interrupted water service to any one customer for more than six (6) hours, the Contractor shall furnish and install a temporary water system. If the water service is disrupted in excess of six (6) hours or without notice, the Contractor is to pay the Utility Company fifty dollars (\$50) for each impacted residential or business unit for each hour beyond the initial six-hour period or the start of an interruption without notice.

If the interruption surpasses twenty four (24) hours without reestablishing water service, then the Utility Company at its discretion will take action to make repairs to reinstate water service, back charge the Contractor and other responsible parties to reinstate water service. The Utility Company may take further action by limiting

the Contractor from working on Utility Company piping and Utility Company controlled services in the future. In addition, the Engineer may consider the Contractor to have substantially violated the terms of the Contract and begin to terminate the Contract as provided for in Division 10, Section 10.05, Article 5.28.

B. Excavation and Backfill

The Contractor is to provide all excavation, backfill, and compaction necessary to install the pipe. Trench excavation and backfill is to be completed in accordance with Division 20, Section 20.13 - Trench Excavation and Backfill. In addition, trenching and excavation is to meet the requirements of 29 CFR 1926.651 and 1926.652 (OSHA Trench and Excavation).

All pipes are to be bedded with Class E bedding unless another material is authorized in writing by the Utility Company. Bedding is to be laid the full width of the ditch and compacted to a minimum of ninety-five percent (95%) of the maximum density.

Water pipe bedding is to extend six (6) inches below and above the pipe and constructed in accordance with Standard Detail 20-8

C. Materials Delivery

Pipe and appurtenances are to be handled in such a manner to ensure delivery to the trench in a sound, undamaged condition. Particular care is to be taken not to damage the pipe, pipe coating, or lining. Before, after and during installation the engineer is to be provided an opportunity to examine the pipe and appurtenances for damage and defects. Damaged or defective pipe may be rejected. Rejected pipe must be removed from the project and replaced with acceptable material at no additional cost.

The pipe is not to be strung out along the shoulders of the road for long distances if it causes inconvenience to the public. The amount of pipe strung at the job site is at the discretion of the Engineer.

Rubber gaskets are to be protected from extended exposure to direct sunlight. Gaskets are to be installed into the piping when the gasket and pipe are above freezing temperature and the gasket is pliable.

D. Connection to existing water lines

The Utility Company issues permits for, witnesses, records live tap locations and sometimes completes taps on a cost reimbursable basis.

Mainline taps two (2") inches and smaller are to be done by the Contractor. The mainline tap must be accomplished with a drilling machine approved for use on the pipe material being tapped, capable of drilling through the tapping saddle and corporation stop and pipe wall.

Tapping saddles are to be used for all taps with the exception that one (1") inch taps into eight inch (8") and larger ductile iron pipe can be directly tapped into the pipe.

Taps are to be made at sufficient distances from each other, tees, bells, joints and other critical areas to prevent compromising the structural integrity of the pipe being tapped. Taps are not to be made any closer than three feet (3') to each other or to a bell.

The Contractor is to schedule Utility Company crews for taps larger than two inches (2") with the Utility Company's department of Customer Service, Field Services section a minimum of three working days in advance of the anticipated need. Reimbursements arrangements are to be made prior to the start of the three working days' notice. Live taps proposed on mains larger than twelve inches (12") or constructed of HDPE may require additional time for ordering and receiving of parts.

The Contractor shall provide all trench excavation, shoring, bracing, backfill and compaction necessary to complete a successful live tap connection. The trench shall be long enough and of sufficient width at the bottom to allow installation of the valve for the live tap connection. The Utility Company will provide the staff, tapping machine, tapping saddle and connection valve. The Contractor shall provide all necessary equipment and manpower to assist Utility Company personnel in moving piping, valves, tapping machines and miscellaneous items into and out of the trench during the entire time Utility Company personnel are working to complete the installation of the water line tap.

For the safety of Utility Company personnel, trenching and excavation is to be completed such that it meets the more stringent requirements of OSHA and the Utility Company's safety program.

Contractor shall excavate for live tap connections in such a manner that the excavation is ninety degrees (90°) to the main water line, whenever possible.

The Contractor shall bear the expenses incurred, if a water main within and directly adjacent to the project site should be damaged during construction. The Utility Company, at its option, will allow the Contractor to make repairs, or the Utility Company will make repairs; however, Contractor shall bear the cost of all material, labor, and other expenses associated with the repair.

Where the Drawings require the connection to an existing valve, the Contractor may choose to use the valve at their risk or replace it at their expense.

E. Installation

Installation is to follow the requirements of AWWA C600, C605, M23, M41 and M55, these specifications, special provisions, and the Utility Company's construction manual and published guidance documents. The Utility Company will have final say when deciding on which requirement the Contractor is to meet where these documents conflict at no additional cost to the Owner.

Deflection at pipe to pipe joints is to be limited to 80% of the maximum deflection angle recommend by the pipe manufacturer for ductile iron pipe

Deflection at pipe to pipe joints is to be limited to 0% of the maximum deflection angle recommend by the pipe manufacturer for polyvinyl chloride pipe

If the alignment requires deflection in excess of the above limitations, the Contractor shall furnish fittings to provide angular deflections within the limits allowable. Short radius curves and closures are to be formed by shorter lengths of pipe, bevels, factory fittings or fabricated fittings.

Where a fitting is provided to change direction, the Contractor is to install a pipe angle marker per the standard details. The marker must be centered over of the fitting.

The interior of the pipe and accessories are to be thoroughly cleaned of foreign matter before being lowered into the trench. The pipe is to be kept clean during laying operation by plugging.

Pipe and appurtenances are to be carefully lowered into the trench by means of derrick, ropes, belt slings, or other suitable equipment. Under no circumstances are any of the pipes or appurtenances to be dropped or dumped into the trench. Care is to be taken to avoid abrasion of the pipe coating. Poles used as levers or skids are to be of wood and have broad flat faces to prevent damage to the pipe and coating. Where any part of the coating or lining is damaged, a repair is to be made by the Contractor at their expense and in a manner satisfactory to the Engineer.

Damage to a factory applied coating on copper pipe is to be repaired with a field applied coating system.

The trench bottom is to be graded to provide uniform support for the pipe barrel. Water is to be kept out of the trench by pumping, if necessary, until the jointing is completed. When Work is not in progress, open ends of the pipe, fittings, and valves are to be securely plugged so that no trench water, earth or other substances will enter the pipes or fittings.

At a distance of not less than forty feet (40') from a known obstacle or tie-in to an existing pipe, the Contractor is to expose and verify the exact location of the obstacle or pipe so that proper alignment and/or grade may be determined before the pipe sections are laid in the trench and backfilled.

Pipe ends left for future connections are to be capped and restrained or as directed by the Engineer. The Contractor is to install vertically an eight foot (8') long wood post, directly over the end of pipe.

Cutting of pipe is to be done in a neat and workmanlike manner without damage to the pipe.

The Contractor is required to use mechanically restrained joints and fittings on all hydrant leads. The Engineer has the option of checking any or all mechanical joints to assure proper torque as specified by the manufacturer.

All ductile iron pipes with affixed fittings are to be encased in one layer of polyethylene encasement. Fittings affixed to non-metallic piping do not need polyethylene encasement. All valve boxes and hydrant barrels are to be encased in three layers of polyethylene encasement.

Water mains and services are to be constructed to meet all separation requirements of 18 AAC 80.020. Variance from the separation requirements

requires a waiver from the Alaska Department of Environmental Conservation and prior approval from the Utility Company.

The Contractor is to stagger the joints for the water pipe such that no joint is closer than nine feet (9') from the centerline crossing of water to sewer. In addition, where water and sewer mains and services intersect, the vertical separation between the water and sewer pipe is to be a minimum of eighteen inches (18") between exterior pipe surfaces.

F. Alignment and Grade

All adjustments to line and grade are to be done by scraping away or filling the earth under the body of the pipe and not by blocking or wedging up.

The Contractor shall continually survey line, grade and location of the pipe and appurtenances with the use of transits and levels during pipe laying operations. Survey is to be completed by qualified personnel to transfer line, grade and record required information. The Engineer will determine qualifications based on submittal of work examples and notes being made in the field when compared to note taking requirements as outlined in Division 65. The Contractor is to replace any personnel the Engineer deems to be less than qualified based on work examples provided or work being performed.

Each piece of pipe is to be laid to within three-one hundredths (0.03) of a foot horizontally and vertically from the design elevation and alignment. Regardless of the limits applied to individual pieces of pipe the accumulated variance of pipe alignment and grade must not be greater than two-tenths foot (2/10' or 0.2'). The Contractor must re-lay the water line when alignment and grade requirements are not met.

Elevations and locations for each piece of pipe and appurtenances are to be recorded in a field book. The Contractor will furnish to the Engineer a copy of the surveyor's notes and redlined drawings for transfer to record drawings. The Contractor is to make any clarifications, corrections or fill in missing data in the survey notes and redlines when requested.

The practice of placing backfill over a section of pipe to provide a platform for instruments is to be subject to the approval of the Engineer and be accomplished in accordance with the trench excavation and backfill requirements

G. Jointing of Ferrous Metal Pipe

The Contractor has the option of using either mechanical or push-on joints. All joints are to conform to the requirements of ANSI/AWWA C600.

Metallic pipe is to have two (2) electrical continuity straps installed on each side of every joint for all pipe diameters. Straps are to be welded to a clean, dry surface. Each exothermic wire weld connection is to be protected with one (1) field applied Royston Handy Cap IP or equal. Uncoated surfaces are to be coated with coal tar pitch to the satisfaction of the Engineer.

H. Jointing of High Density Polyethylene

All HDPE water main piping and fittings are to be butt-fused in accordance with ASTM D2657. Where the Engineer finds that joint fusion is not feasible the Contractor may connect with metallic fittings. The individual who performs the joint fusion is to have written certification from an HDPE pipe manufacturer or supplier stating he/she has successfully completed an 8-hour (minimum) certification class on joint fusion techniques and procedures. In addition, this individual is to have fused a combined total of more than 5,000 feet of HDPE piping in diameters 4-inches and larger.

The Contractor shall ensure that each joint is fused at the temperature and pressure recommended by the pipe manufacturer in order to achieve the maximum pressure rating for that joint. All fused joints for HDPE piping and fabricated fittings are to be documented by a computer data logger that records pressure and temperature applied at each fused joint, along with the date and time the joint was fused. Computer printouts, electronic data, and the project station for each field fused joint is to be submitted to the Utility Company through the Engineer.

The use of electro-fusion couplings to join HDPE piping is not allowed.

I. Jointing of PVC pipe

The Contractor has the option of using mechanical joints or push-on joints. All joints are to conform to the requirements of AWWA C605.

The Contractor is to ensure that the spigot end of the pipe is not inserted into the adjoining pipe bell past the pipe manufacturer's recommended insertion limits.

J. Jointing of Copper pipe

Copper pipe may be joined with the use of silver brazing copper couplers, flared fittings and by swedging and silver brazing. Solder must be lead free silver solder. All joints are to be outside of the rights-of-ways and/or Utility Company easements, unless given prior approval by the Utility Company.

K. Detectable Warning Tape

Detectable underground warning tape is required for installation of all pipe types. The warning tape must be continuously laid with the pipe and be at least twenty four inches (24") and no more than thirty six inches (36") above the pipe.

L. Tracer Wire for Non-metallic Pipe

Tracer wire is to be grounded at all dead ends, except fire hydrant legs. The trace wire is to be connected to the grounding rod with grounding clamps.

Tracer wire is to be securely affixed to the top exterior surface of the pipe using PVC pipe tape at 5-foot intervals or less. Tracer wire is to be looped around valves, saddles, curb stops, and other appurtenances in such a manner that there is no interference with the operation of the appurtenances. Tracer wire must be continuous and without splices, breaks, or cuts except for spliced-in connections as approved by the Engineer. All spliced connections must be inspected by the Engineer before being buried.

Tracer wire must be brought to the surface at all junctions and terminals, including at all valve boxes and fire hydrant legs by splicing into the main line tracer wire. The main line tracer wire must not be broken or cut. Tracer wire is to be spiral-wrapped around the exterior of the valve box riser pipe and brought into the valve box top section. Provide three feet (3') minimum of additional wire neatly coiled within each valve box.

M. Polyethylene Encasement

The Contractor is to install polyethylene encasement as outlined below.

1. Cut a section of polyethylene tube approximately two (2) feet longer than the pipe section. Remove all lumps of clay, mud, cinders, or other material that might have accumulated on the pipe surface during storage. Slip the polyethylene tube around the pipe, starting at the spigot end. Bunch the tube accordion fashion on the end of the pipe. Pull back the overhanging end of the tube until it clears the pipe end.
2. Dig shallow bell hole in the trench bottom at the joint location to facilitate installation of the polyethylene tube. Lower the pipe into the trench and make up the pipe joint with the preceding section of pipe.
3. Move the cable to the bell end of the pipe and lift the pipe slightly to provide clearance to easily slide the tube. Spread the tube over the entire barrel of the pipe. Note: Make sure that no dirt or other bedding material becomes trapped between the wrap and the pipe.
4. Make the overlap of the polyethylene tube by pulling back the bunched polyethylene from the preceding length of pipe and securing it in place. Note: The polyethylene may be secured in place by using tape or plastic tie straps.
5. Overlap the secured tube end with the tube end of the new pipe section. Secure the new tube end in place.
6. Take up the slack in the tube along the barrel of the pipe to make a snug, but not tight, fit. Fold excess polyethylene back over the top of the pipe.
7. Secure the fold at several locations along the pipe barrel (approximately every three (3) feet).
8. Repair all small rips, tears, or other tube damage with adhesive tape. If the polyethylene is badly damaged, repair the damaged area with a sheet of polyethylene and seal the edges of the repair with adhesive tape.
9. Carefully backfill the trench in according to procedures in AWWA C600 Standard. To prevent damage during backfilling, allow adequate slack in the tube at the joint. Backfill should be free of cinders, rocks, boulders, nails, sticks, or other materials that might damage the polyethylene. Avoid damaging the polyethylene when using tamping devices.

Damaged polyethylene encasement is to be repaired or the pipeline removed and the polyethylene encasement replaced at no additional cost.

The requirements of Method A of ANSI/AWWA A21.5/C105 is to be used to make any clarifications to the installation process as outlined above.

N. Fire Lines

No connections, other than those for additional fire protection, will be allowed on the fire line outside the building. Domestic water obtained from a fire line will be connected and metered inside the building.

The fire line riser from the service piping is to be composed of metallic pipe extending vertically from a ninety-degree (90°) fitting through the plane of the building floor. The fire sprinkler riser must be constructed of material in compliance with the NFPA. All below grade metallic piping must be cathodically protected.

O. Relocate Water Main

Where a water main line or service crosses the location of a sewer, the water main is to be raised or lowered sufficiently to permit a minimum (outside diameter) vertical distance of eighteen inches (18") from the sewer line.

The Contractor may employ either of the following methods for raising or lowering a water main.

Raise or lower lengths of the water main as necessary on either side of an obstacle to allow the main to pass under or over the obstacle, providing the deflection at any pipe joint does not exceed the requirements of this Section, or

The water main may be raised or lowered using four (4) pipe bends. The bends are not to exceed forty-five degrees (45°). Where the configuration of lowering the water piping differs from the details provided in this Division, the Contractor is to receive prior approval of the Engineer and Utility Company.

Article 2.5 Flushing and Testing

Flushing and testing is to be completed as specified in the requirements of the referenced AWWA standards unless hereinafter modified. A Utility Company representative, the Engineer, and the Contractor must be present for all flushing and testing.

Flushing and testing is to be completed separately and sequentially starting with pre-disinfecting, flushing, hydrostatic testing, disinfection, and continuity. The Contractor is to provide, install and remove fittings, pipes, pumps, hoses, gauges and other items necessary to perform the flushing and testing.

All water piping, including but not limited to main line, services, fire lines, and fire hydrant legs must be flushed and tested before the piping system can be put into service.

The only exceptions to the chlorination and pressure testing requirements are for non-fire lines constructed of one inch to two inch (1"–2") coated copper pipe that are:

- water service extensions connected to an existing water connection or,
- water service connections that are connected to an existing main that are constructed in conjunction with a water service extension.

Pipe, gaskets, mechanical joints, fittings, valves, hydrants and other water distribution components found to be cracked or defective through flushing and testing are to be removed and replaced with sound material at the Contractor's expense. When repairs are needed to make corrections pass flushing and testing requirements, the flushing and testing procedures are to be restarted for all test sections impacted by the repair.

Each request to supply water for flushing, testing, and disinfecting is to be scheduled in writing with the Engineer and the Utility Company at least forty-eight (48) hours prior to obtaining Utility Company supplied water. Scheduling of flushing, testing, and disinfecting will be subject to water availability. At no additional cost, the Contractor is to modify their schedule to match water availability which may require work on non-working days or outside of normal work shifts.

If the Contractor is not prepared for flushing or testing, they are to provide a cancellation notice to the Engineer and Utility Company at least two (2) hours prior to the scheduled event or the Contractor is to reimburse the Utility Company and Engineer for all expenses incurred by said entities. Expenses will include, but not be limited to, salaries, transportation and administrative costs.

Earthwork for roadways and sidewalks as well as installation of other utilities that share the same frontage as the water distribution system being tested is to be Substantially Complete prior to flushing and testing.

The Contractor is not authorized to operate the Utility Company water distribution system. Only the Utility Company personnel are authorized to manipulate the existing pipe system to supply water for flushing and testing.

The Contractor shall submit, in writing, for the Engineer to review and approve, a schedule and procedure for the testing and flushing of all newly installed pipe. The plan is to include flush and de/chlorinated water handling and discharge procedures. Water discharge locations must receive approval from the governing authority of the discharge location.

When, in the opinion of the Engineer, the testing and flushing schedule and procedure are deficient, inadequate, improper, or conditions are such that the impact to existing water service areas are adversely affected by service interruptions, the Contractor will be notified in writing by the Engineer. Such notification is to be accompanied by a statement of the corrective action to be taken. Contractor shall adhere to the testing and flushing schedule and comply with such instruction as directed by the Engineer.

A. Flushing

All newly installed water pipes are to be open-bore flushed through un-restricted outlets. Flush water is to achieve a minimum velocity of three feet per second (3 ft/sec) and the minimum water quantity flushed at the minimum velocity is to equal three times the quantity of water in the piping being flushed.

The Contractor is to configure the flushing operation, where possible, from higher to lower elevation, utilizing higher pressure mains first, allowing the Utility Company to manipulate the water distribution system to achieve higher than normal pressures and flows to the newly constructed main or other appropriate measures to increase flushing velocities.

Flush piping on service water connections is to be connected to the service water extension side of the key box, extended a minimum of two feet (2') above finish grade and remain in place until the Final Acceptance Date.

Flush water must not be directly connected to the sanitary sewer system. When specifically permitted by the Utility Company, flush water discharged to the sanitary sewer system must be de-chlorinated, have flow regulation with metering, and be limited to the sewer system capacity. The sewer system capacity may exclude discharging to sewer regardless of the flow conditions at the proposed discharge point. The sewer capacity is to be provided in the Special Provisions or the Contractor must obtain the sewer capacity from the Utility Company. The flow provided is based on computer modeling. The actual conditions of the sewer piping may require the Contractor to reduce flow so that the added flow will not cause damage to property.

B. Hydrostatic Testing

All hydrostatic testing will be performed through a test copper. The test station is to be placed at the highest end of the pipe being tested when there is an elevation change in the pipe greater than ten feet (10'). The test pressure is not to exceed the maximum allowable operating pressure of the pipe, fittings, valves, thrust restraints, or other appurtenances of the test section. Use of fire hydrants for testing will not be allowed. The specified test pressure shall be applied by means of an approved pumping assembly connected to the pipe in a manner satisfactory to the Engineer.

When the pressure decreases below the required test pressure during the test period, the pipe being tested will be declared void and will require re-testing.

The Contractor is to incorporate a Utility Company provided test pressure gauge for measuring and determining results of the hydrostatic test. The gauge is to be returned to the Utility Company at the completion of the hydrostatic testing.

The Contractor shall suitably valve-off or plug the outlet to the existing or previously-tested water main at the Contractor's expense prior to making the required hydrostatic test. Prior to testing, all air is to be expelled from the pipe.

If permanent air vents are not located at all high points and dead ends, the Contractor must install and abandon corporation stops at such points so the air can be expelled as the line is slowly filled with water.

All intermediate valves within the section being tested will be closed and reopened during the test. Only static pressure will be allowed on the opposite side of the end valves of the section being tested.

Hydrostatic testing of water lines containing a chlorine mixture above 2 ppm will not be allowed.

The minimum hydrostatic test pressure is to be one hundred fifty pounds per square inch (150 psi) for a minimum duration of thirty (30) minutes for non-fire lines. Fire lines are to be tested at two hundred pounds per square inch (200 psi) for a minimum duration of two hours.

Pumping will be terminated and disconnected upon starting the test. The test pressure at the start of the test is to be maintained for the duration of the test period. Any loss of pressure will be considered a failed pressure test for all pipe types except HDPE.

Newly installed HDPE water main is to be hydrostatically tested to the rated operating pressure of the pipe and appurtenances in two phases. The rated operating pressure of PE4710 HDPE SDR11 piping is two hundred pounds per square inch (200 psi).

Phase 1 – Initial Expansion (4 hours)

Pressurize the test section to the test pressure and maintain for four (4) hours. The contractor is to pump in additional test water into the pipe to maintain test pressure as the pipe expands slightly. It is not necessary to monitor the amount of water added during this phase.

Phase 2 – Pressure Testing (minimum 1 hour)

Immediately following the initial expansion phase the Contractor is to stop adding testing fluid and then reduce pressure by 10 psi. The reduced pressure then becomes the test pressure and is to be held within five percent (5%) for one hour and show no visible leaks to be deemed as having passed the test.

The maximum test duration is eight (8) hours. If the test is not completed in the maximum duration period, then the Contractor is to depressurize the test section completely and allow it to relax for at least eight (8) hours before pressurizing the test section again.

C. Disinfection and Confirmation Testing

The Contractor is to use the Continuous Feed Method to disinfect newly installed water distribution system. AWWA C651 provides various methods for disinfection. The Utility company has found that the tablet, slug and spray methods method are impractical.

The chlorinating agent must be applied at a point of not more than ten feet (10') from the beginning of the project. Under no conditions is the chlorinating agent to be introduced through a fire hydrant.

Water is to be fed slowly into the new water line with chlorine applied in amounts to produce an initial water and chlorine mixture in the pipe of not having less than twenty-five parts per million (25 ppm) of free chlorine. During the chlorination process, all intermediate valves and accessories are to be operated by the Contractor.

The Contractor is to discharge water from the end of all main lines, branches, service connections and extensions until the Engineer verifies that all portions of the newly constructed water distribution system has the initial minimum free chlorine level of the water source supply.

The chlorinated water is to be retained in the piping for a minimum of twenty-four hours (24hrs) and have a minimum residual level of free chlorine of ten parts per

million (10 ppm). At the completion of the twenty-four hour (24hr) period the Engineer is to sample the water. If the free chlorine drops below ten parts per million (10 ppm) the Contractor is to restart the flushing and testing.

The Contractor shall provide a plan for concurrence by the Engineer for disposal of chlorinated waters from the disinfection process. The plan must include a method to dechlorinate and hold the discharge prior to leaving the Contractor's control. Under no circumstances is the solution to be discharged to the sanitary sewer system without prior approval of the sewer Utility Company and the Engineer. Discharges of the spent chlorine solution is to be approved by the authorities have jurisdiction of the receiving facility/site.

After dechlorination is complete, the Contractor shall provide access and accommodate in its schedule for coliform testing. The Engineer with Contractor support is to collect two sets of acceptable samples, taken 16 hours apart, of water from the disinfected piping at the location(s) required by AWWA C651. The samples are to be tested as specified in AWWA C651 Standard Methods for the Examination of Water and Wastewater, and show the absence of coliform organisms. Samples are to be collected by a qualified person and processed in a certified lab.

All preparation and coordination required for disinfection testing and re-testing shall be the responsibility of the Contractor. Additional compensation or contract time extensions for re-testing due to inadequate disinfection will not be granted.

CHLORINATION

<u>Pipe Diameter (ID)</u>	<u>Dosage (oz.) per 100 feet</u>
4"	.34
6"	.76
8"	1.34
10"	2.10
12	3.02
14 and larger	$D^2 \times 3.02$

Where D is the inside pipe diameter (ft)

One Heaping Tablespoon \cong ½ oz.

This table is to be used as a guide for chlorinating water mains by the calcium hypochlorite and water mixture method. This dosage takes into account that contractors most frequently use granular HTH, which is sixty-five percent (65%) pure. If another chlorinating agent is used, the dosage must be adjusted. Caution should be exercised against producing too high a concentration of chlorine in the line.

Disinfection will not be allowed until all open-bore flush pipes are removed and the water system is sealed.

The Contractor may submit a deviation request to the Engineer for review and approval for alternate disinfection plans that meet the requirements of ANSI/AWWA C-651.

D. Continuity Tests

The Contractor shall perform electrical conductivity tests on all ductile iron mains, service connections and service extensions in the presence the Engineer and a representative of the Utility Company.

The Contractor shall maintain a circuit of six hundred (600) amperes DC current for fifteen (15) minutes. To pass the continuity test, the input current may not exceed ten percent (10%) of the return circuit. All equipment necessary to maintain the circuit will be supplied by the Contractor.

The Contractor will perform line tracing on plastic pipe installed with trace wire.

All continuity and tracing tests will be through wires connected to the main and brought to the surface. The use of water service thaw wires, fire hydrants and valves as substitutes for wires will not be accepted. All wires brought to the surface to complete the continuity test are to be placed in a valve box adjustment sleeve.

Where continuity or tracing is not continuous the Contractor, at no additional cost to the Owner, must make necessary repairs/corrections.

Continuity and tracing tests must not be performed until all excavations have been completed and backfilled.

E. Test and Air Vent Copper Pipe Removal

The Contractor is to remove all test and air vent copper pipes upon successful completion of the flushing and testing requirements and install a copper disc in the corporation stop in the presence of the Engineer.

Article 2.6 Measurement

Measurement for furnishing and installing water main line and fire line is per linear foot of horizontal distance of the various sizes as set forth in the Bid Schedule. Measurement will be from station to station as staked in the field and as shown on the Drawings, except where the grade exceeds twenty-five percent (25%), in which case measurement will be by actual pipe length.

Where a water connection, also known as a “live tap”, is completed by the Utility Company on an existing pressurized Utility Company water pipe, these connections are measured as a complete unit in place. All other water connections are incidental to the work taking place.

Raising or lowering of existing water line is measured as a complete unit in place that includes but not limited to piping, fittings, locator tape, disinfection, continuity wire, trace wire polyethylene encasement and the like to make a functioning water system.

Article 2.7 Basis of Payment

Payment for this Work will be in as specified in Division 10, Section 10.07 - Measurement and Payment, and includes full payment for all Work described in this Section.

All requirements for flushing and testing are incidental to the Work.

Variations from the depth of the connection point indicated in the Drawings will not be grounds for additional compensation.

Unless specifically identified for payment under a separate pay item, the unit price bid to includes all labor, equipment and materials to complete the Work including, but not limited to, the following incidental items:

- delivery of non-serviceable portions of removed pipe, valves, and fittings at a Contractor-furnished disposal site;
- delivery of serviceable portions of removed pipe, valves, and fittings to the Utility Company,
- installation of all pipe, tees, crosses, bends, caps, plugs, adapters, reducers, thrust restraint systems, and other fittings;
- installation of pipe angle markers
- installation of thrust blocks;
- adjustment to finish grade;
- protection and/or restoration of all existing utilities;
- maintenance of existing water distribution system flows;
- Trench excavation and backfill;
- Compaction,
- Import classified material and disposal of unusable material
- shoring
- protection of existing light and utility poles;
- maintenance and restoration of existing drainage patterns;
- restoration of existing private or public improvement such as but not limited to:
 - driveways;
 - signage, mail boxes, newspaper boxes,
 - trees and shrubs located on private property;
- landscaping, utility markers, survey monumentation;
- cleanup, and miscellaneous items required to complete the Work as shown on the Drawings.
- Temporary water system for water interruptions lasting longer than 6 hours

Where the Work includes disconnecting existing water services from an existing water line and reconnecting them to a new water line, the disconnection and reconnection of those existing water services will be considered incidental to the price bid for installation of the new water line.

Payment will be made on the following unit bid items:

ITEM	UNIT
Furnish and Install (Size,Type) Pipe	Linear Foot
Furnish and Install (Size,Type) Fire Line	Linear Foot

Connect to Existing Water Line (Connection Size)
Raise or Lower Water Line (Size)

Each
Each

SECTION 60.03 FURNISH AND INSTALL VALVES

Article 3.1 General

The Work under this Section consists of the performance of all Work required for furnishing and installing valves, including valve boxes and marker posts.

Article 3.2 Submittals

Submittals are to be provided to the Engineer for review and acceptance as stated in Division 10, Section 10.05, Article 5.6 – Product Data. The Contractor is to clearly demarcate items to be incorporated into the Work. Submittals for pipe and fittings should include, but is not limited to the following information:

- Manufacturer valve submittal cut sheets
- Valve box
 - Lid
 - Top Section
 - Dust Pan
 - Riser
 - Bottom Section
 - Rubber centering sleeve
- Geotextile

Article 3.3 Material

Tie back rods and/or tie back rod and shackle assemblies are not acceptable as restrained joints or restraining system for valves and valve/pipe joint interface.

Unless otherwise detailed on the Drawings, valve and valve/pipe interface are to be push-on rubber gasket type or mechanical-joints conforming to AWWA C111 and be restrained per Section 60.02.

A. Gate Valves

Gate valves shall be iron body, fully bronze mounted, double disc, parallel or resilient seat valves as specified in AWWA C509 “Resilient-Seated Gate Valves for Water Supply Service” or AWWA C515 “Reduced-Wall, Resilient-Seated Gate Valves for Water Supply Service”.

Gate valve bonnet bolts shall be Type 316 stainless steel with a minimum tensile strength of 75,000 PSI and shall conform to ASTM F593 and F594. All bolts shall be stamped with the grade marking on the head of the bolt, and shall be “T-316”, “316”, or “F593”.

B. Butterfly Valves

Butterfly valves shall be of the rubber-seated tight-closing type. They shall meet or exceed the performance requirements of AWWA C504 for operational pressures of 150 psi working pressure and 300 psi hydrostatic pressure.

Mechanical joint valve ends shall be per AWWA C110/ANSI 21.10 and AWWA C111/ANSI 21.11 of the latest revision, and "Short-Body" in accordance

with the requirements of Table 2 of ANSI/AWWA C504. Accessories (bolts, glands, and gaskets) shall be supplied by the valve manufacturer.

Butterfly valve actuator bolts that are exposed shall be Type 316 stainless steel with a minimum tensile strength of 75,000 PSI and shall conform to ASTM F593 and F594. All bolts shall be stamped with the grade marking on the head of the bolt, and shall be "T-316", "316", or "F593".

Valves must use full ANSI/AWWA C504 Class 150 B valve shaft diameter and full Class 150 B underground service operator torque rating throughout entire travel to provide capability for operation in emergency service.

Valve body shall be high-strength cast iron ASTM A126 Class B. For valves with the rubber seat mounted on the disc, the mating surface in the body shall be 304 or 316 steel. For valves containing the rubber seat in the body, the method of seat retention shall be in accordance with the requirements of ANSI/AWWA C504, except that no retaining fasteners or other hardware shall be permitted in the flow stream.

Valve operators, unless otherwise required by the Contract Documents, shall be of the traveling nut type, sealed, gasketed, and lubricated for underground service and capable of withstanding on overload input torque of four hundred fifty (450) foot-pounds at full open or closed position without damage to the valve or valve operator. The number of turns to operate the valve shall be a minimum of two (2) turns per inch of valve diameter for ninety degrees (90°) of closure travel at a maximum pull of eighty (80) pounds. All valves shall open counterclockwise and be equipped with two inch (2") square AWWA operating nut.

For butterfly valves twenty inches (20") and less, the valve shaft shall be one piece extending full size through valve bearings, disc and shaft seal. In the event that the shaft is turned down to fit connections to the operator, the limits of ANSI/AWWA C504, Section 3.3.2 shall be strictly observed. Carbon steel shafts, if used, shall have 304 or 316 stainless steel journals with static seals to isolate the interior of the disc and the shaft from the water.

For butterfly valves over twenty inches (20"), the valve shaft shall be of two-piece stub shaft type, made of 18-8 Type 304 stainless steel. Valve bearings and shaft seals for valves of all sizes shall meet the requirements of ANSI/AWWA C504 Section 3.6 and 3.7 respectively, with the following additional requirements:

1. Sleeve bearings shall have a maximum coefficient of friction of 0.1.
2. For underground service, packing shall be pressure-energized chevron or "O" ring type, not requiring adjustment and suitable for permanent duty.

C. Pressure Reducing Valves

Pressure reducing valves are to be supplied as directed in the Special Provisions.

D. Valve Boxes

Valve boxes are to be constructed of the following individual parts:

Lid – cast or ductile iron with lifting ears that conforms with and fits closely with the top section and is rated heavy duty

Top section - cast or ductile iron, rated heavy duty, 18" minimum height, minimum 6" inner diameter, recessed to receive the lid

Dust pan – cast or ductile iron, 3" minimum height, ¼" minimum thick material, lift handle/bar and fits into and rests on the riser

Riser – cast or ductile iron pipe that fits inside the top section and over the bottom section, 10' long delivered to the Work site

Bottom section – cast or ductile iron, rated heavy duty, 24" minimum height, with round or oval bottom hood sections to fit over the top of the valve

Geotextile – woven, class 2 in conformance with MASS Section covering geotextile fabric

Polyethylene film – 8 mil in conformance with this Division.

Rubber centering ring –a rubber compound sleeve placed on a valve to align the valve box bottom section with the valve top, such as the Valve Box Adaptor II or equal. The centering ring must conform to the shape of the valve and valve box to seal out soil.

Tape – minimum 2" wide, 20 mil thick, UPC approved PVC Tape

Heavy duty rated items are to meet AASHTO M306 criteria. Internal diameter of the smallest section shall not be less than five inches (5"). Minimum thickness of the metal shall not be less than five-sixteenth inch (5/16"). Castings shall be smooth and the workmanship shall be acceptable to the Engineer.

E. Markers

A two and one-half inch (2.5") O.D. galvanized steel pipe, painted "navy blue", seven feet (7') in length, with three feet (3') buried in the ground is to be placed at the nearest property line to mark the location of all valve boxes outside of paved areas. Unless otherwise directed by the Engineer, the marker is to be placed no more than fifty feet (50') away from the valve being marked. The marker is to have two inch (2") "caterpillar yellow" lettering stenciled near the top of the above ground portion of the marker indicating what the marker is for, swing distance to the valve and general direction from the marker to the valve. The notation is to be presented as "VB (feet) (direction)" with "VB" being within two inches (2") of the top of the marker.

Article 3.4 Construction

Valve interiors are to be cleaned of all foreign matter before installation. If the valve is at the end of the line, it is to be plugged prior to backfilling. The valve shall be inspected by the Contractor in the open and closed positions prior to installation to ensure that all parts are in working condition.

Place the rubber centering ring inside the bottom section over the valve bonnet. After placement of the bottom section the Contractor is to wrap three (3) layers of woven geotextile fabric around the outside of the valve and bottom section of the valve box. The geotextile is to be secured in place with PVC pipe tape to the bottom section and pipes. Encase the valve box assembly with three layers of eight-mil (8 mil) polyethylene, encasement, taped securely in place.

Valve box components are to be plumb and centered over the operating nut.

The butterfly valve operators are to be placed on the side of the water main away from the centerline of the street or easement.

Regardless of what is shown on the Drawings, a valve is to be installed outside the building so that all fire hydrants will remain in service in the event water service to the building must be shut off.

After final inspection of valves located in unpaved areas the Contractor is to place Class 'E' bedding directly over the valve box lid to final grade elevations. The Contractor must expose and rebury all valve boxes for pre-final and final inspections in unpaved areas. Valve box lids in paved areas are to be exposed and accessible.

Locations where replacing a valve box assembly is required it is to be removed by excavating to fully expose the valve and connecting pipes then reconstructed to the requirements of this section and the standard details.

Locations where replacing a valve box riser is required it is to be removed by excavating to the top of the valve box bottom section and reconstructed to the requirements of this section and the Standard Details.

To adjust an existing valve box top section to finish grade, the valve box top section, lid and dust pan are to be removed by excavating and reconstructed to the requirements of this section and the Standard Details.

Valve box components removed are to be replaced with materials meeting this section and not re-used in any portion of the Work.

Article 3.5 Measurement

Furnishing and installing valves will be measured as a whole unit designated by type and size inclusive of all parts required to provide a functioning valve including but not limited to valve, valve connection components, bottom section, riser, top section, dust pan, lid, markers, elevation adjustments, and corrosion/intrusion/frost protection per these specifications, special provisions, standard details and Drawings.

Replacement of valve boxes will be measured as complete units in place including but not limited to the bottom section, riser, top section, dust pan, lid, markers and corrosion/intrusion/frost protection.

Replacement of valve box risers will be measured as complete units in place including but not limited to the riser, top section, dust pan, lid, markers and corrosion/intrusion/frost protection.

Adjustment of valve box top sections to finish grade will be measured as complete units in place at the Engineer approved elevation that includes the removal and replacement of the valve box top section, dust pan, lid and provides for polyethylene encasement.

When the bid item includes the removal and replacement of valve box components, then those same components will not be measured for payment under any other bid item.

Disposal of removed parts will not be measured for payment and is considered incidental to the item being constructed.

Unless specifically identified for payment under a separate pay item, the unit price bid to complete the Work includes all costs, labor, equipment and materials to complete the Work including, but not limited to, the following incidental items:

- Excavation;
- Backfill and compaction;
- Import of classified material
- Markers,
- Disposal of unusable material;
- Removal and replacement of ground surface features
- adjustment to finish grade;
- protection and/or restoration of all existing utilities;
- maintenance of existing water distribution system flows;
- shoring excavations
- protection of existing light and utility poles;
- restoration of existing private or public improvement such as but not limited to:
 - driveways;
 - signage, mail boxes, newspaper boxes,
 - trees and shrubs located on private property;
- landscaping, utility markers, survey monumentation;
- cleanup, and miscellaneous items required to complete the Work as shown on the Drawings

Article 3.6 Basis of Payment

Payment for this Work is to be as specified in Division 10, Section 10.07 - Measurement and Payment, and shall include full payment for all Work described in this Section.

Payment shall be made on the following unit:

ITEM	UNIT
Furnish and Install (Size) Gate Valve	Each
Furnish and Install (Size) Butterfly Valve	Each
Remove and Replace Valve Box	Each
Remove and Replace Valve Box Riser	Each
Remove and Replace Valve Box Top Section	Each
Remove and Replace Valve Box Lid	Each
Remove and Replace Valve Box Dust Pan	Each

SECTION 60.04 FURNISH AND INSTALL FIRE HYDRANTS

Article 4.1 General

The Work under this Section consists of the performance of all Work required for the furnishing and installation of "L-Base" Fire Hydrant Assemblies, including the fire hydrant leg pipe, auxiliary gate valve, anode(s), valve box, joint restraint, guard rails and/or posts, coatings, wrappings and fire hydrants.

Article 4.2 Submittals

Submittals are to be provided to the Engineer for review and acceptance as stated in Division 10, Section 10.05, Article 5.6 – Product Data. The Contractor is to clearly demarcate items to be incorporated into the Work. Submittals for fire hydrants should include, but is not limited to the following information:

- Manufacturer fire hydrant submittal cut sheets with the selected ordering options clearly marked.
- Valve and valve box riser components
- Thrust restraint system
- Corrosion protection items

Article 4.3 Materials

A. Fire Hydrants

Fire hydrants are to conform to the requirements of ANSI/AWWA C502 for Dry Barrel Fire Hydrants. Fire hydrants are to be Mueller Super Centurion, American Darling 5-1/4 B62B with 20" nozzle section or equal.

1. The operating nut of the hydrants is to be a minimum of twenty eight (28") above the traffic breakaway flange. The traffic breakaway flange is to be between three inches (3") to nine inches (9") above adjacent grades.
2. All single pumper hydrants are to be furnished with a six inch (6") ANSI Class 125 standard mechanical-joint end. All double pumper hydrants must be furnished with an eight inch (8") ANSI Class 125 standard mechanical-joint.
3. All connections are to be mechanical-joint unless otherwise indicated in the Contract Documents.
4. Single pumper hydrants must be furnished with two (2) two and one-half inch (2.5") hose connections and one (1) four and one-half inch (4.5") pumper connection. Double pumper hydrants are to be furnished with one (1) two and one-half inch (2.5") hose connection and two (2) four and one-half inch (4.5") pumper connections.
5. Unless otherwise required by the Contract Documents, all hydrants are to be furnished with a barrel length that will allow a minimum of ten feet (10') of bury. The lower barrel must be one piece to achieve a ten foot burial depth.
6. The main valves are to be of the compression type, where water pressure holds the main valve closed permitting easy maintenance or repair of the entire barrel assembly from above the ground without the need of a water shutoff.

7. All fire hydrants must be furnished with a breakaway flange which allows both barrel and stem to break clean upon impact from any angle. Traffic flange design must be such that repair and replacement can be accomplished above ground.
 8. Painting and coating are to be shop coated in accordance with cited AWWA Specifications. The paint is to be federal standard color 595B, Code 13538.
 9. Operating and nozzle nuts are to be pentagon shaped with one and one-half inch (1.5") point to flat measurements.
 10. Hose nozzle threading must be in conformance with NFPA #194 for National (America) Standard Fire Hose Coupling Screw Threads.
 11. All working parts are to be bronze or noncorrosive metal in accordance with the requirements of ANSI/AWWA C502.
 12. All hydrants are to be right hand opening (clockwise).
 13. All hydrants must not drain. Drain plugs are to be securely installed.
 14. All fire hydrants are to be supplied with a five and one-fourth inch (5.25") main valve opening.
 15. Brass components in contact with potable water are to comply with Public Law 111-380 (No Lead Rule).
- B. Auxiliary Gate Valves
All gate valves and valve boxes are to be furnished and installed as specified in Section 60.03 - Furnish and Install Valves.
- C. Thrust-Restraint System
Fire hydrants are to be fully restrained back to and include the connection to the main line. Thrust restraint is to be furnished and installed as specified in Section 60.02 – Furnish and Install Pipe.
- D. Guard Posts
The Contractor shall install guard posts for each hydrant installation as shown with the Standard Details. If, in the opinion of the Engineer, the guard posts are not to be installed, they are to be delivered to the Utility Company storage yard.

Article 4.4 Construction

The Contractor is to complete all trench excavation, backfill and compaction necessary to install the fire hydrant assembly.

An eight foot (8') wide clear, slightly sloping (max 5% in any direction) access path that extends four feet (4') beyond the fire hydrant must be provided. Where a ditch is encroached upon by the access path, the ditch is to be relocated or filled and a twenty four inch (24") diameter culvert installed to pass run off by the hydrant.

The Contractor shall field coat the barrel section, shoe, MJ restraint, and all buried bolted connections with a coating that meets the requirements of Section 60.02 – Furnish and Install Pipe, Article 2.3 - Material, item H – Field Applied Coating. In addition to the field applied coating, the Contractor shall wrap the hydrant barrel section with three layers of 8-mil thick polyethylene encasement, up to the finish ground surface.

The fire hydrant auxiliary valve is to be closed during installation and remain closed during all main line open bore flushing operations. The Contractor is to open the auxiliary gate valve for hydrostatic pressure testing, disinfection and for hydrant raising. The hydrant leg must have hydrostatic pressure for the hydrant to be raised. The Utility Company will raise hydrants on a cost reimbursable basis to the heights provided by the Contractor. All fire hydrant legs are to be installed level. The fire hydrant barrel is to be installed plumb. The Contractor will provide the Utility Company with a minimum of seventy-two (72) hours advance notice, excluding weekends and holidays, to coordinate fire hydrant adjustment. The Contractor is responsible for access to the hydrant location and all trench excavation, dewatering and backfill operations prior to, during, and after the fire hydrants are adjusted by Utility Company personnel. The cost for coordinating and raising the fire hydrant is incidental to the fire hydrant installation.

All fire hydrants that have yet to be approved for use must be covered and identified as being "not in service". The cover is to be firmly secured to the hydrant. Not in service bags are to be at least 27" wide x 42" tall x 4 mil thick polypropylene material, brightly colored (e.g. orange, yellow, green) and in bold black print clearly show in large, easy-to-read lettering the words "NOT IN SERVICE".

The Contractor must paint in two inch (2") black lettered stenciling, the direction and distances to the nearest one-tenth foot (1/10' or 0.1') of the fire hydrant auxiliary valve box. The lettering is to be placed on the face of the fire hydrant directly below the bonnet flange.

Article 4.5 Measurement

The method of measurement to furnish and install fire hydrants is to be as follows:

A. Single Pumper Fire Hydrants

Single Pumper Fire Hydrants are to be measured as complete assemblies furnished, constructed, installed, and accepted in place for each installation, including, but not limited to, fire hydrants six inch (6") leg to main, six inch (6") auxiliary gate valve and valve box, guard post installation, coatings, coverings, and thrust-restraint system. The price must include full compensation for furnishing and installing single pumper hydrants as shown in the Standard Details, required by these specifications and shown in the Drawings.

B. Double Pumper Fire Hydrants

Double Pumper Fire Hydrants are to be measured as complete assemblies furnished, constructed, installed, and accepted in place for each installation, including, but not limited to, fire hydrants eight inch (8") leg to main, eight inch (8") auxiliary gate valve and valve box, guard post installation, coatings, coverings and thrust-restraint system. The price is to include full compensation for furnishing and installing double pumper hydrants as shown in the Standard Details, required by these specifications and shown in the Drawings.

Article 4.6 Basis of Payment

Payment for this Work is to be as specified in Division 10, Section 10.07 - Measurement and Payment, and includes full payment for all Work described in this Section.

Payment is to be made under the following units:

ITEM

UNIT

Furnish and Install Fire Hydrant Assembly (Single Pumper) Each
Furnish and Install Fire Hydrant Assembly (Double Pumper) Each

SECTION 60.05 WATER SERVICE LINES

Article 5.1 General

The Work under this Section consists of the performance of Work required for furnishing and installing water service lines including but not limited to tapping, connecting, piping, fittings, key boxes, and valve boxes at the location and depth required by the Contract Documents.

The exact location, type, and size of existing Water Service Connections are to be considered unknown. All information provided in the Contract Documents and provided by the Utility Company is from maintenance records, record drawings, field surveys and represents the Utility Company's best indication of location and size. The Utility Company cannot be held liable for accuracy of the information. The Contractor shall locate and confirm that the service extension will function prior to beginning the work.

A permit must be purchased from the Utility Company permit section prior to any water service construction (either on or off property in the Utility Company service area). The permit is to be displayed at the job site. The Utility Company permit does not relieve the Contractor from obtaining all other necessary permits.

The Contractor is to notify the Utility Company a minimum of twenty-four (24) hour in advance of any required or needed inspection.

Before an on-property service line permit for a new subdivision can be released for construction, all property corners must be established and identified.

Article 5.2 Submittals

Submittals are to be provided to the Engineer for review and acceptance as stated in Division 10, Section 10.05, Article 5.6 – Product Data. The Contractor is to clearly demarcate items to be incorporated into the Work. Submittals for water service lines should include, but is not limited to the following information:

- Piping – See Section 60.02
- Corporation stop
- Curb stop
- Key box
- Key box rod
- Flare nuts
- Valve and valve box riser components
- Thrust restraint system
- Corrosion protection items
- Continuity and trace wire

Article 5.3 Material

A. Pipe

Pipe material must comply with Section 60.02 – Furnish and Install Pipe

B. Key Box, Curb Stop, Corporation stop, valve and Valve boxes

Keyboxes are to be telescoping, furnished with a lid, have an arch pattern base and is to be constructed of cast or ductile iron. The operating rod and connection pin are to be constructed of stainless steel alloy type 304 or 316. The connection pin is to be a minimum of 3/16" by two inches (2") long and inserted completely through cast connection head that is welded to the operating rod. Bent plate connection heads will not be allowed.

Curb stops (key box valves) are to conform to AWWA C800, be rated for 150 psi working water pressure, have a waste port, be NSF 61 certified, accept copper flare nuts on both ends and conform to the "no lead" standard for parts in contact with potable water. For one inch (1") services, the flare nut on the Utility side of the curb stop is to come with an integral wire connector for an anode connection. For services greater than one inch (>1"), a bronze direct burial compression pipe clamp is to be used in conjunction with a flare nut.

Corporation stops/valves shall be PTFE coated brass ball valves, rated for 300 psi water pressure, conform to AWWA C800, be NSF 61 certified, and conform to the "no lead" standard. Inlet end shall have the AWWA/CC taper and outlet end shall have copper flare straight connection. The corp shall come with a flare with an integral wire connector (up to one-inch) and a bronze direct burial compression pipe clamp thaw nut for sizes greater than 1-inch. Corp shall be Mueller B25000-07 corp and thaw nut, AY MacDonald 74701BA 1 NL corp stop with anode connection, or equal.

All valves and valve boxes must be as specified in Section 60.03 - Furnish and Install Valves.

C. Continuity and Trace Wire

Continuity and Trace wire are to meet the requirements of Section 60.02 – Furnish and Install Pipe.

Article 5.4 Construction

Water service piping and valves are to be constructed as outlined in Section 60.01, Section 60.02 and Section 60.03 with the following special considerations.

The Contractor is to familiarize themselves as to the depth of the water main for the project through Contract Documents, gathering field data and record data. The Contractor must excavate whatever substances that are encountered to the depth required for the connections. The Contractor is to expose the main to be tapped for a minimum distance of two feet (2' on either side of the proposed tap location and below the pipe for proper clearance of the tapping saddle.

The Contractor is responsible for all costs for damaging Utility Company controlled piping included by not limited to damage during excavation, tapping or backfilling. The Utility Company will make repairs, then issue back charges and penalties to the Contractor for the repairs. If approved by the Utility Company, the Contractor may repair the damaged main.

Except where shown on Utility Company approved Drawings, The Contractor shall lay water connections at ninety degrees (90°) to the street line. Water service piping is to have a minimum of ten foot 10' of bury from the point of connection to a point five feet (5') inside the building footing. Where the main line has less than ten foot of bury, the service must be immediately lowered to achieve the required bury depth and insulated where there is less than ten foot of bury. Water services are not to be within a horizontal distance of ten feet (10') or have less than eighteen inches (18") of vertical separation at crossings to a sewer or footing drain. Services must not cross property lines.

Trenches are to be OSHA compliant and have a minimum of two and one-half feet (2.5') wide bottom for a single copper water service. The service is to be centered in the ditch and the thaw wire laid at the edge. Where multiple copper services are laid in the same trench, the services must have a minimum separation of two feet (2') and the key boxes must not be separated more than twelve feet (12'). Non-copper services cannot share the same excavation.

Key boxes shall be of an acceptable construction as shown in the Standard Details and the requirements of the Specifications. Key boxes are to be installed at the furthest point of Utility Company maintenance, which is typically at the property or utility easement line, whichever is a greater distance from the water mainline. The key box must not be installed horizontally closer than:

- ten feet (10') to a known or proposed structure, street light, utility pole transformer pad, electrical/telephone/cable box, and other utility pedestals, sewer piping
- five feet (5') to a property line,
- fifteen feet (15') to a fire hydrant or hydrant leg

The Contractor will relocate any service not meeting the separation requirements at their own expense. Valve box adjustment sleeves as defined in Section 60.03 – Furnish and Install Valves are to be used for key boxes located in pavement or concrete.

Key and valve boxes are to be installed plumb, be centered over the water line valve, have an unobstructed access way, and be wrapped with eight mils (8-mils) thick polyethylene encasement. Key and valve boxes must not be in contact with other utility lines, such as but not limited to gas, electric, telephone or cable.

Where key box and valve box locations are not shown on a plan they shall be installed in the standard location as shown in the Standard Details or as found in the Utility Company's Design and Construction practices manual.

Keyboxes located within pavement or concrete are to be adjusted to finish grade and installed in a valve box adjustment sleeve. Adjustment of keyboxes is to be accomplished by removing the keybox lid, installing a black iron pipe coupling, installing a section of black iron pipe, and replacing the keybox lid at the finish grade.

Services stubbed to the property line or beyond for future use must have a bleeder pipe brought above grade, be marked at the end of the service with a 2" X 4" X 8' marker, protruding three (3') feet above grade, painted blue, and stenciled with the word "WATER" in white two (2") inch high letters near the top.

Existing key boxes identified on the Drawings for adjustment are to be adjusted to be flush with the final ground surface when in non-paved areas. If excavation is required to adjust the existing key box, the ground surface will be restored to its original condition unless otherwise indicated in the Drawings. The Contractor shall be responsible for ensuring that the key box is vertical, clean, to the proper grade, and readily accessible for operation of the curb stop.

Existing key boxes to be lowered will include adjustment of the telescoping riser, cutting excessive length of key box, threading, and installing threaded unions to complete adjustments. Only threaded joints will be allowed. "Quick-connect" style connections assembled with set screws will not be accepted.

Any damage to a key box resulting from construction under this Contract will be repaired or replaced at the Contractor's expense.

The Contractor is to record the as-built vertical and horizontal locations of the water service, service length, bottom of pipe elevations at the main and property line, key box, and valves based on the survey control provided in the Drawings. When survey control is not provided to the contractor, the recording of the as-built information is to be relative to two permanent fixed points such as, but not limited to, manholes, valve boxes, building structures and property corners. The fixed point cannot be living, movable (e.g. boulders, rocks, fence posts), or changing attributes of something larger (e.g. sidewalk cracks, building paint schemes). The record information must be turned into the Utility Company prior to the Utility Company allowing the water service to be turned on.

At such time as the Engineer may direct, but only after the service lines and appurtenances have been properly completed and inspected, the trenches and appurtenant structures may be backfilled in accordance with the construction requirements found in Division 20, Section 20.13 – Trench Excavation and Backfill.

The Contractor shall exercise due care in backfilling to keep the service box and continuity wire vertical and in place. In the event the service box or continuity wire is displaced, the Contractor will be required to excavate and restore the service box and continuity wire to the proper position. Any work necessary to restore the service box and continuity wire to the proper position will be performed at the Contractor's expense.

A continuity wire is to be attached to the corporation stop on one inch (1") connections with a flare tube nut with integral wire connector. The continuity wire is to be attached to the saddle on the main for one and one-half (1 1/2") and two inch (2") connections.

Hydrostatic testing must comply with Section 60.02 – Furnish and Install Pipe. A bleeder will be installed at each service line key box and extended a minimum of two foot (2') above the existing ground. The Contractor is to cap all bleeders after testing is complete. The bleeder may not be used for the on-property system and must be disconnected at the time of the on-property extension.

No unions will be allowed in the right-of-way on newly constructed service lines.

All on-property installations are to be constructed to the same standard as off-property installations.

Repair of water services typically involves the replacement of piping. When the piping is constructed of copper pipe the new pipe is to meet current standards and be connected

to the existing pipe through the use of silver brazing with copper couplers, swaging the copper line or use of Flare x Flare three-part unions. Flare x Flare unions will not be allowed for use within the rights-of-ways and easements. Furnish and install a reducer if the existing water service extension piping differs in size to new piping. Furnish and install dielectric union if existing water service line piping is of dissimilar metal from new piping.

Article 5.5 Measurement

Measurement for Furnishing and Installing Water service Lines shall be per linear foot of horizontal distance of the various sizes set forth in the Bid Schedule. Measurement will be from station to station as staked in the field and as shown on the Drawings, except where the grade exceeds twenty five percent (25%), in which case measurement will be actual pipe length.

Measurement for connection to new on-property service line or existing service line are considered incidental to the Contract, and no separate payment will be made for this Work.

Adjusting existing key boxes will be measured per unit, complete in place. Adjustment of key boxes installed with a service line will not be measured.

Article 5.6 Basis of Payment

Payment for this Work will be as specified Division 10, Section 10.07 - Measurement and Payment, and includes full payment for all Work described in this Section.

Adjusting of all key boxes installed with a service will not be paid for separately from the service.

Unless specifically identified for payment under a separate pay item, the unit price bid to Furnish and Install (size) Water Service Lines includes all costs, labor, equipment and materials to furnish and install a functional potable water service including, but not limited to, the following incidental items:

- verify location of existing water services;
- disconnection and reconnection of customer's existing services where the Work includes replacement of existing services;
- clearing and grubbing;
- trench excavation and backfill;
- excess excavation and backfill;
- excavation dewatering;
- trench support system;
- furnishing and installing Class E pipe bedding;
- compaction of fill;
- installation of pipe,
- fittings, adapters, or other necessary appurtenances;
- polyethylene encasement;
- hydrostatic testing, flushing, and disinfection;
- water service insulation;
- disposal of unusable or surplus material;
- seeding; protection of existing utilities;

- restoration of existing drainage patterns;
- removal and replacement of existing culverts, guardrail, fences, landscaping, and other public or private improvements; finish grading;
- cleanup

Where the Work includes disconnecting existing water services from an existing water line and reconnecting them to a new water line, the disconnection and reconnection of those existing water services will be considered incidental to the costs bid for installation of the new water line.

Fittings and appurtenances as shown on the Drawings or not specifically identified for payment under a separate pay item but required for normal completion of water service line installation, will be considered incidental and will be included in the linear foot cost of the water service lines.

Payment is to be made under the following unit:

ITEM	UNIT
Furnish and Install (Size) Water Service Line	Linear Foot
Remove and Replace Key Box	Each
Adjust Key Box	Each
Adjust Key Box (Concrete Slab or Asphalt Paving)	Each

SECTION 60.06 FURNISH AND INSTALL GALVANIC ANODES

Article 6.1 General

The Work under this Section consists of the performance of all Work required for furnishing and installing galvanic anodes for added protection of water pipe from corrosion. The Contractor shall install galvanic anodes in accordance with these specifications and in conformity with the Standard Details or as shown on the Drawings.

Article 6.2 Submittals

Submittals are to be provided to the Engineer for review and acceptance as stated in Division 10, Section 10.05, Article 5.6 – Product Data. The Contractor is to clearly demarcate items to be incorporated into the Work. Submittals for anodes should include, but is not limited to the following information:

- Anodes
- Lead wire
- Thermite Welding
- Anode connectors

Article 6.3 Materials

A. Anodes

Anodes utilized for typical galvanic anode system installation are prepackaged magnesium style anodes weighing twenty (20) pounds. Anode composition is to be in accordance with ASTM B843-2003 Table 1, Grade HP, M1C.

Anodes are to be packaged in a low resistive backfill consisting of seventy-five percent (75%) gypsum, twenty percent (20%) bentonite, and five percent (5%) sodium sulfate.

Anodes shall be provided with #10 AWG stranded copper, single-conductor cable with HMWPE insulation. Lead wire cable shall be rated for six hundred (600) volts and designed for direct burial applications.

B. Pipe Connection Lead Wire

Lead wires must be of sufficient length for splice-free routing between the anode and the pipe and is to be #10 AWG stranded copper, single-conductor cable with HMWPE insulation. Lead wire cable must be rated for six hundred (600) volts and designed for direct burial applications.

C. Thermite Welding Equipment and Materials

Equipment and materials used to bond the #10 AWG HMWPE to the pipeline is of the “CADWELD” type as manufactured by ERICO Products, Inc. of Cleveland, Ohio, or approved equal. Thermite weld caps, designed to protect the CADWELD bonds from corrosion, is to be Royston “Handy Cap 2” or approved equal.

Article 6.4 Construction

The following is a list of general procedures utilized for typical installation of galvanic anodes:

1. Anode Placement

Anodes are to be installed eighteen to thirty-six inches (18" to 36") from the side wall of the pipe, to a centerline depth in line with the approximate horizontal plane of the pipe's bottom dead center. Anodes are to be placed on alternating sides of the pipeline and a frequency of no less than one anode per every pipe section (joint) that is greater than nine feet in length. One anode may not protect more than twenty seven feet (27') of pipe segments. One anode on all fittings within a twenty foot (20') radius as long as all fittings are electrically connected to the anode.

2. Lead wire connection from anode to pipe, anode to fitting, fitting to fitting

The #10 AWG HMWPE lead wires must be attached to the top dead center of the pipe. Lead wire connections to the pipe are to utilize exothermic weld connection methodology and follow the manufacturer's instructions for use.

Lead wire connections to fittings are to be done with a stainless steel metal plate with two holes through the plate. One hole is to be placed and sized 1/8" larger than the fitting bolt to allow the fitting bolt to pass through the hole. The second hole is to be 5/16" in diameter to allow connection of the anode lead wire with a 1/4" diameter by 1" long stainless steel bolt with a nut and locking washer. The anode lead wire is to be fitted with a 5/16" diameter wire ring terminal. Were a connector plate is used, the Contractor must ensure a metal to metal connection is made to all metallic parts being protected by the anode.

3. Backfilling

Extreme care shall be taken not to damage the anodes or direct buried lead wires during backfill procedures.

Article 6.5 Measurement

Measurement for furnishing and installing anodes will be per each anode installed. The price includes full compensation for furnishing and installing anodes as described herein and as shown on the Drawings.

Unless specifically identified for payment under a separate pay item, the unit price bid to complete the anode installation includes all costs, labor, equipment and materials to complete the Work including, but not limited to, the following incidental items:

- Connection of anode to pipe or fitting
- Excavation;
- Lead wire, jumper wires, connectors, bolts, nuts, washers
- Backfill and compaction;
- Import of classified material
- Disposal of unusable material;
- Removal and replacement of ground surface features
- adjustment to finish grade;
- protection and/or restoration of all existing utilities;
- maintenance of existing water distribution system flows;

- shoring excavations
- protection of existing light and utility poles;
- restoration of existing private or public improvement such as but not limited to:
 - driveways;
 - signage, mail boxes, newspaper boxes,
 - trees and shrubs located on private property;
- landscaping, utility markers, survey monumentation;
- cleanup, and miscellaneous items required to complete the Work as shown on the Drawings

Article 6.6 Basis of Payment

Payment for this Work is as specified in Division 10, Section 10.07 - Measurement and Payment, and includes full payment for all Work described in this Section.

Payment is to be made under the following unit:

ITEM	UNIT
Furnish and Install Anode	Each

SECTION 60.07 TEMPORARY WATER SYSTEMS

Article 7.1 General

The Work under this Section consists of the performance of all operations pertaining to the construction, installation, maintenance and removal of temporary water service. It is the intent of this Section that the Contractor maintains water service during the entire period of construction activities to all current customers that would be impacted by an extended water service interruption (longer than six hours (6 hrs))

The Contractor will not be allowed to gain access to interior plumbing, residences, commercial space or other portions of the project outside of the right of way to assess the amount of work required to install a temporary plumbing system prior to a notice to proceed.

The Contractor is to assume that exterior plumbing connection points (e.g. hose bibs) are at the furthest distance from the main feeder line for the temporary water system. Exterior plumbing connections are to be hydrostatically tested for leaks at a test pressure equivalent to ten feet of head prior to connecting to the exterior plumbing. When a leak is detected by witnessing a loss of pressure during the test, the Contractor is to discontinue testing immediately and find the next available exterior connection point and repeat the testing procedure. Where the Contractor cannot find a suitable exterior connection point and the Contract Documents do not provide for an interior connection point, then the Contractor shall immediately notify the Engineer.

Where modifying of interior plumbing is required, the Contractor should plan for making and documenting multiple contact attempts, working outside of usual hours, and moving and replacing objects of substantial size such as but not limited to dressers, couches, washers, dryers, plants, storage boxes, etc... to gain access to interior plumbing. In addition where the Contractor is to modify the building to gain access to the plumbing, they are to assume the removal and replacement of at most five square feet of sheet rock in addition to the plumbing. Removal and replacement shall match the existing building material to the satisfaction of the owner of the building. The Contractor is to practice "lead safe" requirements for building modifications that disturb lead-based paint in pre-1978 homes, child care facilities, and schools where the Work must be performed by an EPA Certified Renovator working for an EPA Certified Firm and specific work practices must be implemented to prevent lead contamination. The Contractor is to use the Municipality of Anchorage Geographical Information Systems or by other means to determine the year of construction prior to bidding and make this information available to their workers during the execution of the Work.

Article 7.2 Submittal

Submittals are to be provided to the Engineer for review and acceptance as stated in Division 10, Section 10.05, Article 5.6 – Product Data. Submittals for temporary water systems should include, but is not limited to the following information:

- Temporary Water Plan

Where an ADEC approved temporary water plan is not provided in the Drawings, the Contractor shall create and submit a plan for any temporary water systems to the State of Alaska, Department of Environmental

Conservation (ADEC) for review and approval prior to installing the system. The plan must identify the type of system, the method of construction and the maintenance and operation procedures to be used. The plan must identify service to each existing customer except those who agree in writing to have their service temporarily disconnected. The Contractor shall obtain such agreement at their own expense. To be submitted with the plan are any agreements between the Contractor and property owner regarding access and use of private property. The methods to be employed in maintaining water service are left to the Contractor. Surface piping, trailer mounted supply systems, and so forth may all be considered as long as they comply with current health standards and requirements. A copy of the ADEC approved plan is to be provided to the Engineer and Utility Company, along with copies of any agreements with property owners referred to above.

The Contractor shall also submit the name and phone number of a contact person and at least one alternate who shall be available on a twenty-four (24) hour basis for repair and/or maintenance of the temporary water system to the Engineer and to the Utility Company.

- Temporary Water Individual Components

See the Section on furnish and install pipe for requirements relating to pipe and fitting submittals. At a minimum the following items are to be included in the submittal:

- Pipe
 - Fittings
 - Backflow preventer
 - meters
 - Fire Hydrant
 - Pipe routing schematic
- For Contractor created temporary water plans, the plan is to provide calculations showing capacity of the temporary water system meeting the water demands for typical use and fire protection.
 - Lead Based Painting certification

Article 7.3 Material

The Contractor shall use only those materials and equipment listed in this Section to supply temporary water service. Temporary water service is to be supplied under the service criteria outlined in this Section. All equipment used must be specifically designed and properly disinfected for the storage, handling, and delivery of potable water.

Materials used for temporary water service is to conform to the requirements of this Division. Where Work is performed for a temporary basis of less than three (3) months the requirements for stainless steel and epoxy coating will not be required.

The primary water feeder pipe is to be a minimum of three inches (3") in diameter for residential temporary water systems that serve less than 25 single family residents. For

all other cases the Contractor is to provide the pipe sizes supported by engineered calculations signed and sealed by an Alaskan Registered Professional Engineer.

Article 7.4 Construction

The following minimum criteria are to be used for service to each structure:

- Forty (40) psi minimum, one hundred (100) psi maximum delivery pressure measured at the connection to the structure.
- Five (5) gallons per minute flow at the above delivery pressure measured at the connection to the single family residential structure. Multi-family residential, Commercial and other business structures may require higher water flows.
- Potable water system and water quality is to conform to 18AAC 80 Alaska Drinking Water Standards.
- All services to structures are to have a valve and backflow preventer installed to allow individual control of service to each structure.

All temporary water service equipment is to be flushed and disinfected per MASS Section 60.02 - Article 2.5 Flushing and Testing, ANSI/AWWA C652, Disinfection of Water Storage Facilities and ANSI/AWWA C651, Disinfection of Water Mains. All bacteriological samples required under these Specifications are to be done by a testing laboratory certified by the State of Alaska. Any visible leaks in the temporary water system are to be repaired.

All temporary service equipment is to be disinfected prior to connecting to a residence or business and be disinfected each and every time the equipment is moved or connected to another residence or business.

The Engineer is to be notified twenty-four (24) hours prior to the installation of any temporary water system. The Engineer and Utility Company shall be present to inspect the disinfection process of any temporary water service system.

No residence presently service by the Utility Company system is to be without water for a period greater than six (6) hours in any twenty-four (24) hours period. Each residence or business owner is to be notified seventy-two (72) hours before they are transferred on or off the temporary water system and before any other service interruption. Prior to constructing temporary water services on private property, the Contractor shall secure a written "Right of Entry" from the property owner.

All Right of Entry agreements are to provide indemnification in accordance with Division 10, Section 10.06, Article 6.10 – Indemnification. The Contractor is to provide a copy of each "Right of Entry" agreement to the Engineer.

Where it is necessary to prevent the back-feeding of temporary water through the service connects to complete the Work, the Contractor shall install a functional shut-off valve on the dwelling plumbing system. The new shut-off valve is to be used to isolate the building plumbing system from the water main during the work. The Contractor will be responsible for entering the private property building and installing a new shut-off valve.

Installation of a new shut off valve that requires any work that modifies the building, including but not limited demolition, removal, replacement or reconstruction of walls, flooring, concrete slabs or other parts of the structure and/or plumbing is to be

completed to the satisfaction of the property owner and Engineer. The Contractor is to match to the greatest extent possible the existing conditions of the building. The Contractor is to obtain and provide a copy of a written verification that the property owner has accepted any reconstruction.

Modification to the building plumbing system to install a functional shut-off valve is to be accomplished by a plumber who is a licensed by the State of Alaska and the Municipality.

The Contractor is to obtain and comply with required permits from the Municipality's Department of Community Development, Development Services, Building Safety or their successor for all work associated with the installation of the shut-off valve.

Where in the opinion of the Engineer the Contractor has done due diligence to obtain a right of entry and complete the installation of the shutoff valve but has been refused access by the property owner and/or resident of the structure then the Utility Company is to be brought in to enforce Tariff for Water Service provisions that require access to premises.

The Contractor will be required to obtain a hydrant permit from the Utility Company and will be required to meet all permit conditions (winter use of a hydrant requires special permission from the Utility Company).

The Contractor shall provide a gate valve assembly and backflow prevention device at the connection point of the temporary water piping to the Utility Company piping/hydrants. The Contractor is responsible for repairing any damage caused by the connection of the temporary water system to the Utility Company's water system at no additional cost.

In the event that the Contractor fails to repair and/or maintain the temporary system and the Utility Company or Owner is required to perform repairs and/or maintenance, all costs associated with said repairs and/or maintenance may be deducted from the Contract amount.

Article 7.5 Measurement

Providing temporary water service for the project is measured as lump sum and includes installation, removal and restoration activities associated with providing a disinfected and functioning temporary water system meeting the requirements of this section.

Modification of building plumbing is paid separately from the temporary water system. Modification of building plumbing will include all costs associated with modifying the building plumbing, including but not limited to, permitting, structure demolition and reconstruction, valves, right of access agreements, and public relations.

Article 7.6 Basis of Payment

Payment for this Work is to be as specified in Division 10, Section 10.07 - Measurement and Payment, and includes full payment for all Work described in this Section.

Payment is to be made under the following unit:

ITEM	Unit
Temporary Water System	Lump Sum

Modify Building Plumbing (Size, Type) without Structure Demolition and Reconstruction	Each
Modify Building Plumbing (Size, Type) with Structure Demolition and Reconstruction	Each

SECTION 60.08 DECOMMISSION WATER SYSTEM AND COMPONENTS

Article 8.1 General

The Work under this Section includes all operations pertaining to decommissioning water system pipe lines, wells, fire hydrants and other applicable components. Where shown on the Drawings, required for platting actions, building removal, land use changes or otherwise directed by the Engineer or Utility Company, the Contractor is to decommission and salvage identified components of the water system.

Article 8.2 Submittals

Submittals are to be provided to the Engineer for review and acceptance as stated in Division 10, Section 10.05, Article 5.6 – Product Data. Submittals for decommissioning water systems should include, but is not limited to the following information:

- Concrete, Grout, sand slurry, bentonite mixtures and placement plan
- Temporary water and shutdown plan
- See Section 60.02 - Furnish and Install Pipe, for fittings required to separate the abandoned system from the active system.

Article 8.3 Material

Sand slurry consists of a mixture of water and sand with an approximate ratio of seven (7) gallons of water per cubic foot of sand. Sand may consist of native material with a particle size distribution such that one hundred percent (100%) of the material passes the No. 4 U.S. Standard Sieve and contains no lumps, frozen material, organic matter, or other deleterious material.

Grout is to consist of a Portland cement, water, lime and sand. Portland cement is to be Type II, Sand is to meet the requirements of sand slurry.

Concrete is to be class C-6 in accordance with MASS Division 30.

Solid copper retainer disc (Mueller Co. Catalog No H-15535) or equal.

Article 8.4 Construction

A. General

Decommissioning will require the Contractor to excavate, expose and remove different parts, pieces and assemblies of the water system as well as salvage identified components. Salvaged pieces are to be delivered to the Utility Company. The ends of the water lines four inch and greater that are remain in service (pressurized) are to be capped, restrained, and backed up with a thrust block. A Utility Company representative must witness all decommissioning. Water lines to remain in service after abandonment of adjacent pieces are to be disinfected in accordance with AWWA C651.

The Contractor is to restore the area of Work to preconstruction conditions. The Contractor is to provide written notice to the Engineer forty-eight (48) hours prior beginning decommissioning Work.

B. Water Main

The decommission in place method of water mains requires emptying the line, placing of a one foot (1') thick concrete plug with vent tube at the higher end of the line, filling the pipe with a quantity of sand slurry or grout mixture equal to the total calculated volume from the newly installed plug to the point of injection then finally placing a one foot concrete plug at the injection end of the pipe. The concrete plugs the pipe and the slurry fills the pipe. Work is typically started on the downhill end of the pipe.

In the event the pipeline to be abandoned is cracked or crushed, the Contractor shall excavate to the next joint of pipe and install the plug. Crushed pipe sections or portions thereof are to be removed and disposed of by the Contractor.

Where the main is being decommissioned by removal, the Contractor is to excavate down to and remove the water pipe.

C. Water Service

Water service decommissioning requires a disconnect permit from the Utility Company. To obtain the Utility Company disconnect permit the Contractor is to provide to the Utility Company and Engineer a schedule, disconnect location (lot, block, subdivision name, address), and record of who will perform the service disconnect. The Contractor is to post the Utility Company permit and the Right-of-Way permit at the job site.

The abandonment method for disconnection of a copper water service at the main line will include turning off the corporation stop at the main, cutting or disconnecting the copper at the corporation stop and thaw wire, placement of a solid copper retainer disc in the corporation stop, removal of the key box with operating rod, and providing a record of the service connection location via swing ties to permanent structures.

Abandonment of larger services requires that the service line must be capped and or blind flanged at or cut out of the main. This may include, but not be limited to, removal and replacement of water main pipe, blind flanging tapping sleeves, capping tees. In most cases this work will require a water turnoff.

D. Fire Hydrant

The hydrant assembly is all pipes, fittings, valves and other parts from the tee at the main and/or service to and including the fire hydrant.

Upon inspection of the exposed hydrant assembly components, the Engineer will determine which components are to be salvaged. Non-salvageable parts are to be transported by the Contractor to a disposal site approved for disposal of construction debris.

The hydrant assembly components to be removed and salvaged at each hydrant location where the hydrant is to be salvaged include:

- Hydrant assembly (head, barrel, and shoe)
- Hydrant gate valve
- Hydrant gate valve box

- Hydrant leg

The Contractor shall install a plug in the branch connection on the tee in the water main where the hydrant assembly is removed. If the water main is to be returned to an active state then the plug is to be visually checked for leakage by the Engineer and Utility Company Inspector. At no additional cost, the Contractor will be required to expose the cap if it is buried and the Engineer has not completed the visual check for leakage. In most cases this work will require a water turnoff.

E. Well

The Contractor shall use the following procedure when abandoning wells:

1. Remove the existing well pump and appurtenances. The well pump and appurtenances are to be carefully removed to avoid damage and delivered to the property owner after removal.
2. Backfill the well casing to ten feet (10') above the screen with disinfected sand or gravel. Sand is to be used as backfill adjacent to water bearing strata consisting of sand. Gravel is to be used as backfill adjacent to water bearing strata consisting of gravel. Disinfected sand or gravel is defined as sand or gravel washed in a one part per million chlorine/water solution prior to the backfilling operation. The Contractor is to provide proof to the Engineer that any imported sand or gravel has been disinfected prior to backfilling the casing.
3. If the aquifer is pressurized, place a seal over the top of the disinfected sand or gravel to seal the aquifer. The seal may consist of bentonite chips or other suitable means, as approved by the Engineer.
4. Backfill the next section of well casing for a minimum distance of ten feet (10') with concrete or cement grout. If necessary, the depth of the concrete or cement grout may have to exceed ten feet (10') to ensure the lower aquifer is thoroughly sealed. The concrete or cement grout is to be placed from the bottom upward through a pipe or tremie tube in such a way as to avoid segregation or dilution of the material. The concrete or cement grout is to be cured for a minimum of thirty-six (36) hours prior to proceeding with the next step.
5. Backfill the next section of well casing to fifteen feet (15') below the ground surface with gravel. Disinfected gravel is not required in this zone.
6. Excavate the area adjacent to the top of the well to a depth of five feet (5') and cut the casing at this level. Then backfill the remaining ten feet (10') of well casing with bentonite, concrete, or cement grout. Weld a metal cap on top of the well casing to ensure the well is sealed. Mark the cap stating that the well is abandoned with the date of abandonment.
7. Backfill the area within a two foot (2') minimum radius from the center of the well casing to a level which is two inches (2") above the top of the sealed well casing with concrete or cement grout to preclude the downward migration of water along the outside of the casing. Then backfill the remainder of the excavated hole with native soils and restore the Work site.

8. As part of this bid item, the Contractor shall be responsible for topsoil and reseeding all lawn areas damaged by the Contractor during the well abandonment operation. In addition, the Contractor shall be responsible for the repair and/or replacement of all existing utilities, driveways, trees, utility markers, survey monuments, fences, retaining walls, buildings, sidewalks, gardens, landscaping, and other private improvements damaged by the Contractor as a result of the well abandonment operation.
9. The Contractor shall provide a log of the well abandonment to the Engineer prior to receiving final payment for this Work. The log is to describe the materials used in the abandonment and the depths below existing grade each type of material was used, in addition to any other pertinent information regarding the abandonment.
10. The Contractor is to obtain well information through investigation if the well logs are not provided herein.

The Contractor may employ, at his/her option, an alternate method of abandoning the wells that conforms to the requirements of ANSI/AWWA Standard A 100. In the event the Contractor elects to obtain approval to employ an alternate method, he/she shall first secure the approval of the ADEC and then submit a Substitution Request form to the Engineer for approval. The substitution request is to clearly identify the method the Contractor wishes to employ; clearly reference applicable sections of ANSI/AWWA Standard A 100 which allow the Contractor's proposed method of abandonment; and, include written approval from the ADEC specific for these particular wells.

Article 8.5 Measurement

Salvage and disposal costs are to be included in the bid item and will not be measured separately.

Quantity measurement for pipeline to be decommissioned in place is per linear foot for each nominal pipeline size regardless of type of pipe. For pipe to be decommissioned in place no separate measurement will be made for pipe removed due to damaged ends.

Quantity measurement for pipeline to be decommissioned by removal will be made based on the Engineers measurement and observations.

Quantity measurements for decommissioning water services are on per each basis regardless of the effort required to locate the connection point to the main.

Quantity measurements for decommissioning wells are on a per each basis which includes but not limited to verifying the well construction and removal of internal and external components.

Quantity measurement for removal of fire hydrants are per each and includes costs of salvaging and delivering parts and pieces as described above.

Unless specifically identified for payment under a separate pay item, the unit price bid to complete the Work includes all costs, labor, equipment and materials to complete the Work including, but not limited to, the following incidental items:

- Excavation;
- Backfill and compaction;
- Import of classified material
- Disposal of unusable material;
- Removal and replacement of ground surface features
- adjustment to finish grade;
- protection and/or restoration of all existing utilities;
- maintenance of existing water distribution system flows;
- shoring excavations
- protection of existing light and utility poles;
- restoration of existing private or public improvement such as but not limited to:
 - driveways;
 - signage, mail boxes, newspaper boxes,
 - trees and shrubs located on private property;
- landscaping, utility markers, survey monumentation;
- cleanup, and miscellaneous items required to complete the Work as shown on the Drawings
- maintenance of vehicular traffic and/or pedestrian access

Costs incurred for completion of these incidental Work items are considered including in the bid unit cost.

Article 8.6 Basis of Payment

Payment for this Work is to be in accordance with Division 10, Section 10.07 - Measurement and Payment, and includes full payment for all Work described in this Section.

Payment is to be made under the following unit:

ITEM	UNIT
Decommission Pipeline in Place (Pipeline Nominal Size)	Linear Foot
Decommission Pipeline by Removal (Pipeline Nominal Size)	Linear Foot
Decommission Water Service 3/4" to 2" copper pipe	Each
Decommission Water Service (Pipeline Nominal Size) (Type of Pipe)	Each
Decommission Well (Size, Depth)	Each
Decommission Fire Hydrant Assembly (Type)	Each

**MUNICIPALITY OF ANCHORAGE
STANDARD SPECIFICATIONS**

**DIVISION 60
WATER SYSTEMS
STANDARD DETAILS**

**STANDARD CONSTRUCTION SPECIFICATIONS
DIVISION 60
INDEX OF STANDARD DETAILS**

60-1	MJ Cap and Plug
60-2	Relocate Water Main (Sewer/Storm Drain)
60-3	Tracer Wire
60-4	Joint Bonding
60-5	Typical Pipe Angle Marker
60-6	Thrust Block
60-7	Mid-Span Thrust Block
60-8	Typical Valve Box (VB)
60-9	Dust Pan with Thaw Wires
60-10	Single Pumper “L” Base Fire Hydrant Assembly
60-11	Double Pumper “L” Base Fire Hydrant Assembly
60-12	Fire Hydrant Guard Posts
60-13	1” Water Service Connect
60-14	Water Service Connect - 1-1/2” and 2”
60-15	Irrigation System
60-16	Adjust Service Key Box
60-17	Small Diameter Water Service Under Foundation
60-18	Large Diameter Water Service Under Foundation
60-19	Water Service Extension Stub
60-20	Anode Detail
60-21	Anode Wire Connection

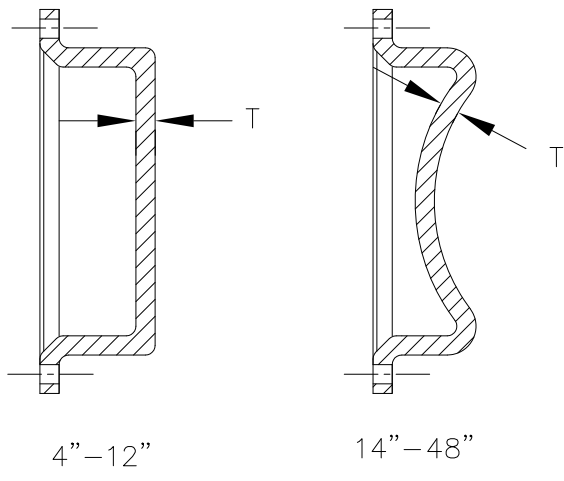

MJ
CAP

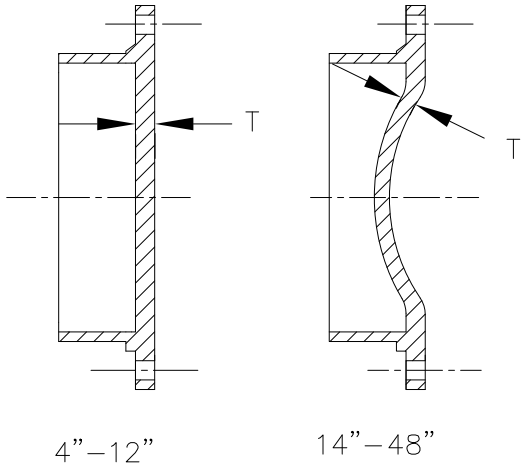

MJ
PLUG

- NOTES:
1. MECHANICAL JOINT RESTRAINT EBAA IRON MEGALUG OR EQUAL.
 2. COST OF THIS FITTING TO BE INCLUDED IN BID PRICE OF PIPE.
 3. T = THICKNESS PER AWWA C110 OR C153 STANDARDS.



SCALE:
NTS

APPROVED:

REVISED:
1/2015

MJ CAP AND PLUG

SECTION #
60.02

DETAIL #
60-01

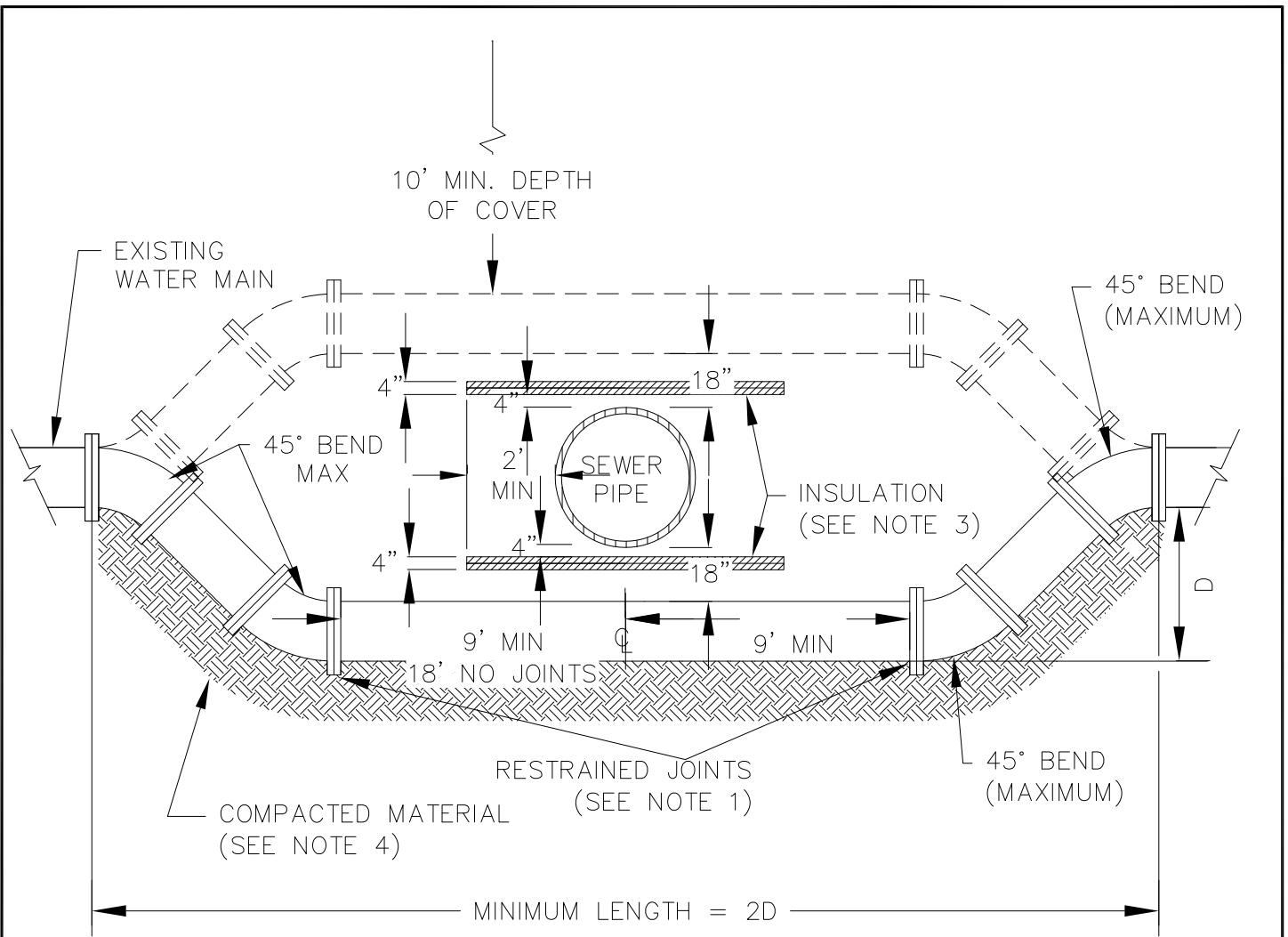

NOTES:

1. ALL PIPE AND FITTINGS SHALL BE RESTRAINED BY USE OF MEGALUG® AND/OR FIELD LOK® GASKETS OR EQUAL.
2. RELOCATED WATER MAIN SHALL HAVE A MINIMUM SEPARATION OF THIRTY-SIX INCHES (36") BETWEEN STORM AND WATER. IF LESS THAN THIRTY-SIX INCHES (36") OF SEPARATION CANNOT BE OBTAINED THEN FOUR INCHES (4") OF INSULATION IS REQUIRED. IF EIGHTEEN INCHES (18") OF SEPARATION CANNOT BE MAINTAINED BETWEEN WATER AND SEWER OR STORM AN ADEC WAIVER IS REQUIRED.
3. RIGID BOARD INSULATION MUST BE HIGH DENSITY POLYSTYRENE, MIN. 60 P.S.I., EQUIVALENT TO R-20 PER FOUR INCH (4") THICKNESS. INSULATION SHALL BE BE POSITIONED NO LESS THAN OR EQUAL TO FOUR INCHES (4") FROM SEWER PIPE.
4. ALL MATERIALS USED TO RELOCATE WATER LINE SHALL BE APPROVED BY THE ENGINEER.

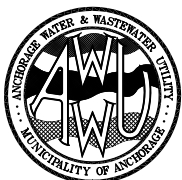

SCALE:
NTS
APPROVED:
REVISED:
1/2015

RELOCATE WATER MAIN (SEWER/STORM DRAIN)

SECTION #
60.02

DETAIL #
60-02

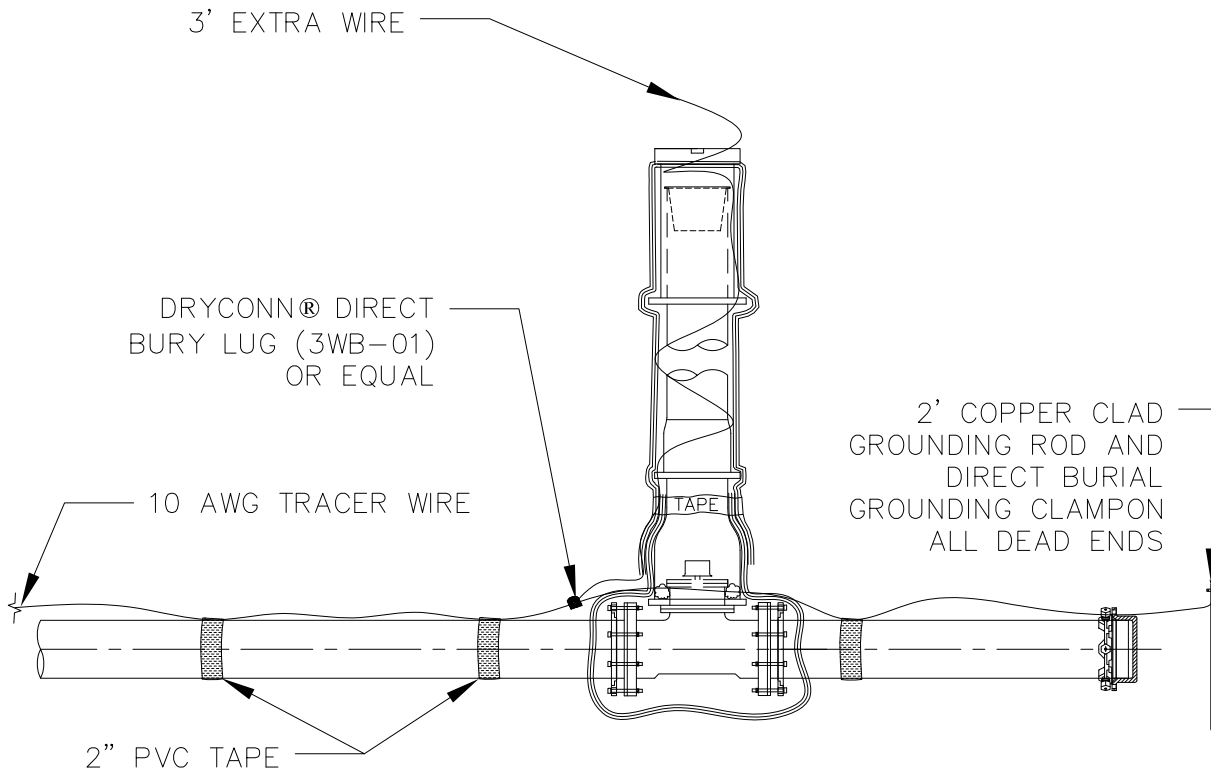

NOTE:

1. RUN A DIRECT BURIAL #10 AWG SOLID (.1019" DIAMETER), STEEL CORE SOFT DRAWN HIGH STRENGTH TRACER WIRE, 600# AVERAGE TENSILE BREAK LOAD, 30 MIL HIGH MOLECULAR WEIGHT-HIGH DENSITY BLUE POLYETHYLENE JACKET COMPLYING WITH ASTM-D-1248, 30 VOLT RATING TRACER LINE CONTINUOUSLY ALONG THE PVC MAIN LINE, TAPING IT TO THE PIPE EVERY 5' WITH 2" WIDE 10 MIL. PVC PIPE TAPE.
2. SPLICE A WIRE ON AT EVERY VALVE RISER AND BRING LOCATE WIRE UP INTO THE VALVE CAN WITH 3' OF EXTRA WIRE USING A DRYCONN® DIRECT BURIAL LUG (3WB-01) OR EQUAL, FOLLOWING MANUFACTURES RECOMENDATIONS.
3. INSTALL GROUNDING RODS ON BOTH ENDS AND AS REQUIRED.

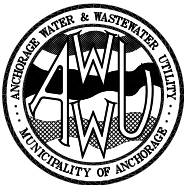

SCALE:
NTS
APPROVED:
REVISID:
1/2015

TRACER WIRE

SECTION #
60.02

DETAIL #
60-03

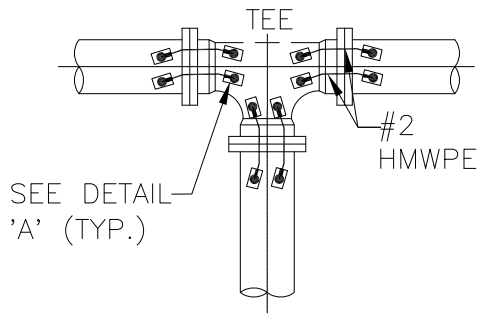

JOINT BONDING OF A TEE

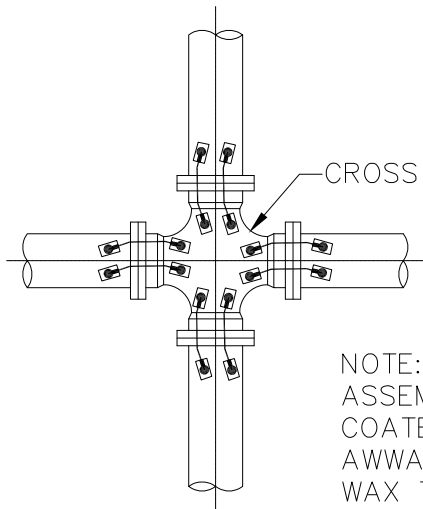

JOINT BONDING OF A CROSS

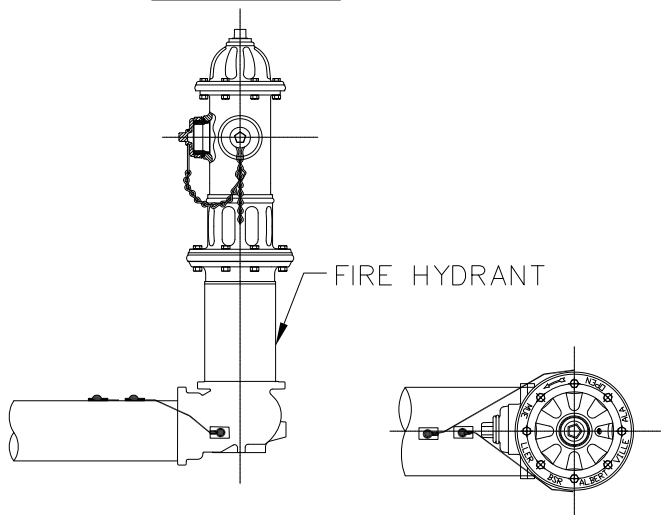

SIDE VIEW

TOP VIEW

JOINT BONDING OF A HYDRANT

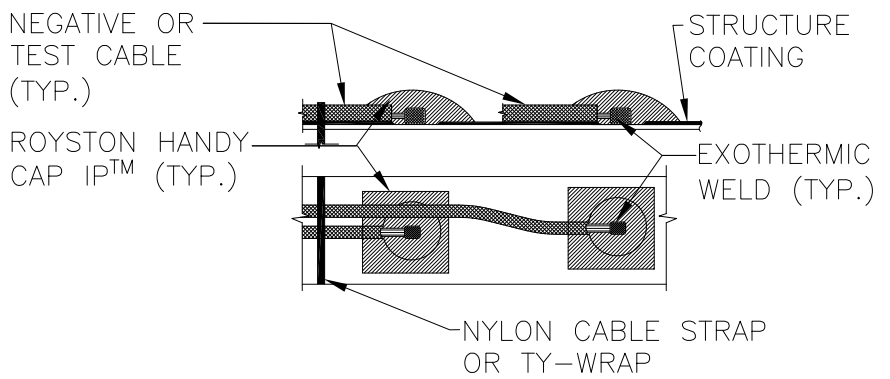

DETAIL 'A'

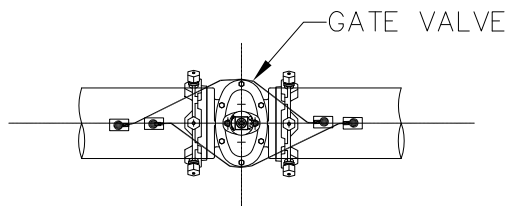

TOP VIEW

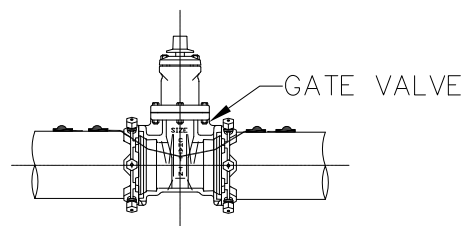

SIDE VIEW

JOINT BONDING ACROSS VALVE

NOTE: ENTIRE VALVE ASSEMBLY TO BE FIELD COATED WITH 4-PART AWWA C217 WAX TAPE SYSTEM.

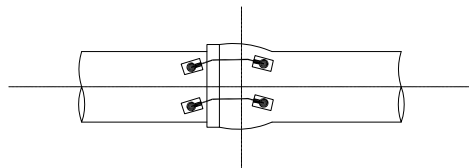

JOINT BONDING BELL/SPIGOT PIPE

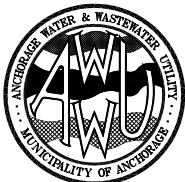

SCALE:
NTS
APPROVED:
REVISOR:
1/2015

JOINT BONDING

SECTION #
60.02

DETAIL #
60-04

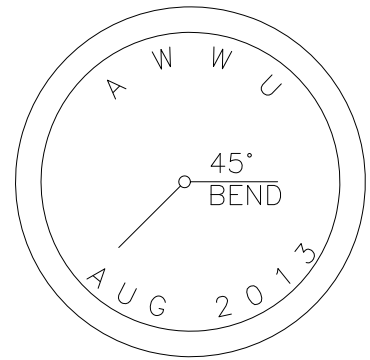
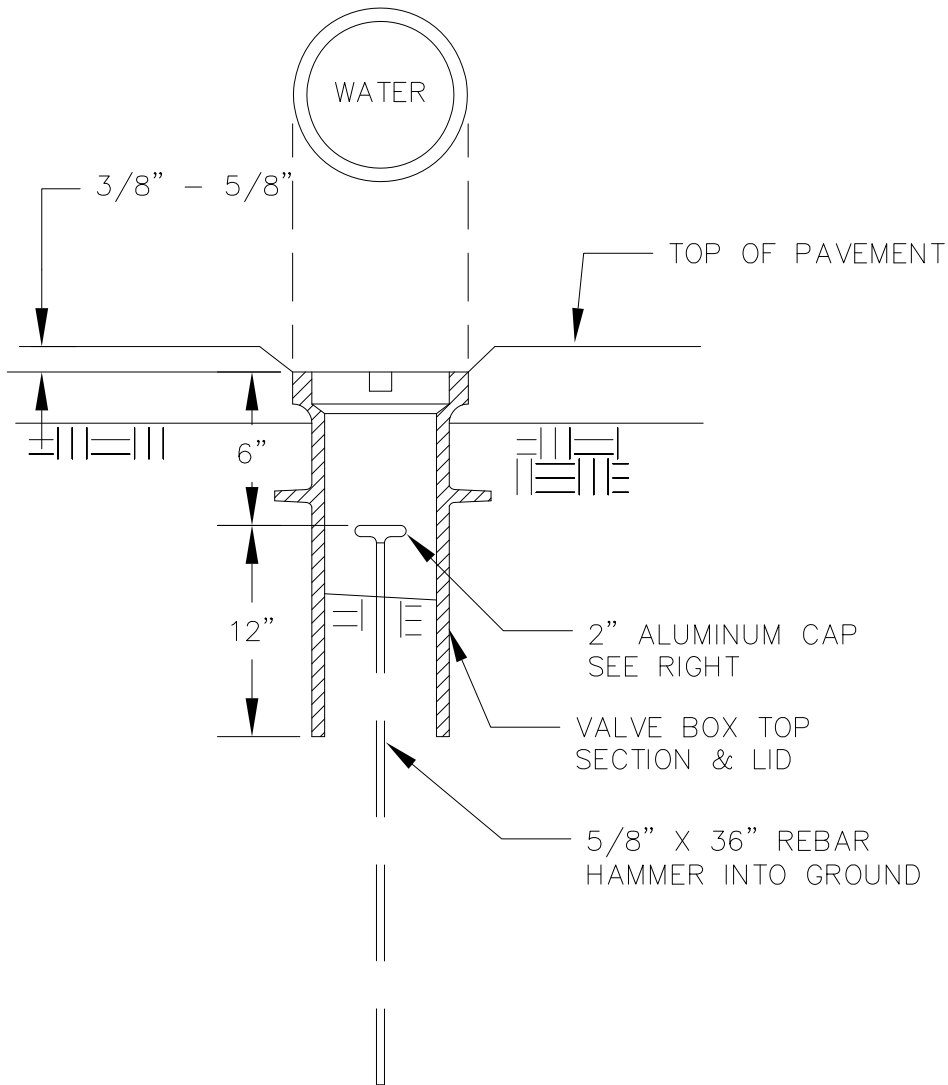

2" ALUMINUM CAP

NOTE: BEND SHOWN ON ALUMINUM CAP SHALL MATCH ACTUAL INSTALLED WATER MAIN BEND.

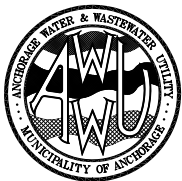

SCALE:
NTS

APPROVED:

REVISED:
1/2015

TYPICAL PIPE ANGLE MARKER

SECTION #
60.02

DETAIL #
60-05

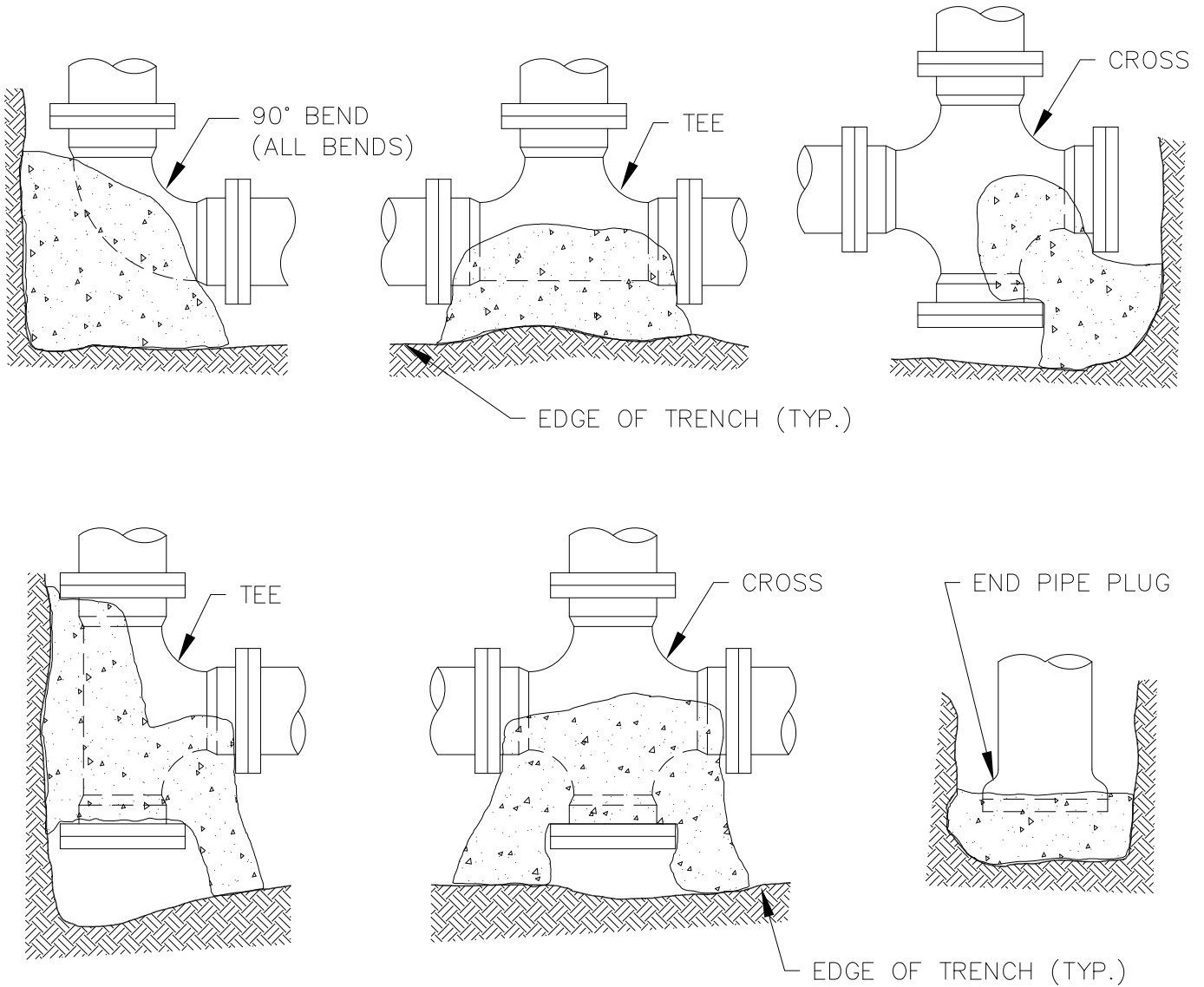

NOTE:

1. MINIMUM THICKNESS OF PRE-CAST CONCRETE THRUST BLOCKS SHALL BE 6-INCH OR AS PER THE CONTRACT SPECIFICATIONS, AND IN CONFORMANCE WITH DIVISION 30 OF MASS.
2. THRUST BLOCK MAY NOT BE USED IN LIEU OF THRUST RESTRAINT
3. CAST IN PLACE THRUST BLOCKS MUST BE CAST AGAINST UNDISTURBED SOIL (HATCH)

MINIMUM BASE AREA SQUARE FEET				
PIPE SIZE	PLUG	90° BEND	45° BEND	22 1/2° BEND
6"	2.0	2.0	1	1
8"	2.5	2.5	1.5	1.5
10"	4.5	4.5	2.5	2.5
12"	6	6	3.5	3.5
14"	8	8	4.5	4.5
16"	10.5	10.5	6	6
24"	24	24	13	13

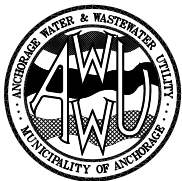

SCALE:
NTS

APPROVED:

REVISED:
1/2015

THRUST BLOCK

SECTION #
60.02

DETAIL #
60-06

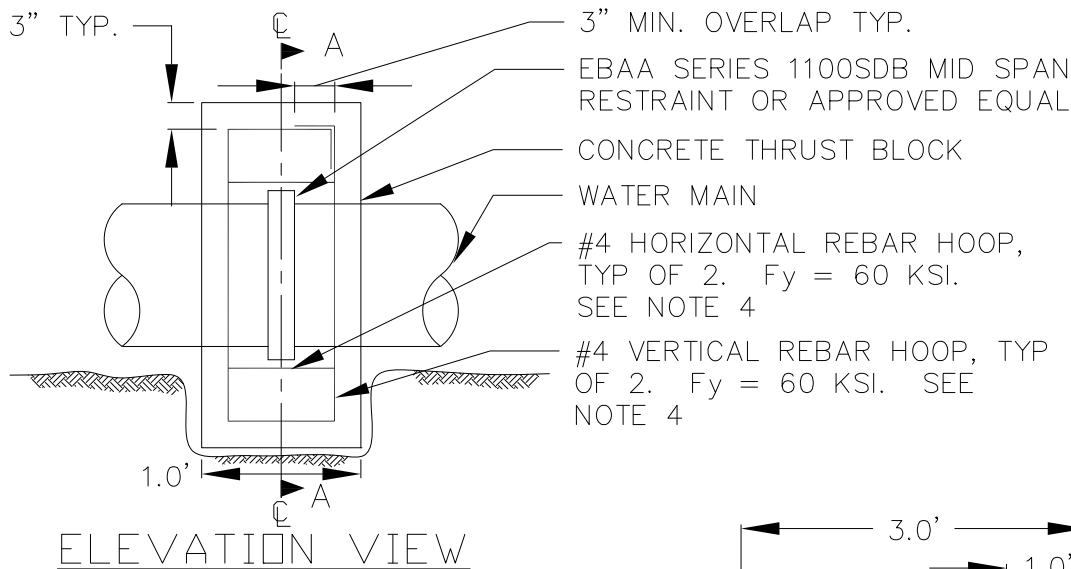

EBAA SERIES 1100SDB MID SPAN RESTRAINT OR APPROVED EQUAL

WATER MAIN (8")

#4 REBAR HOOP, TYP. $F_y = 60$ KSI. SEE ELEVATION VIEW

CONCRETE THRUST BLOCK

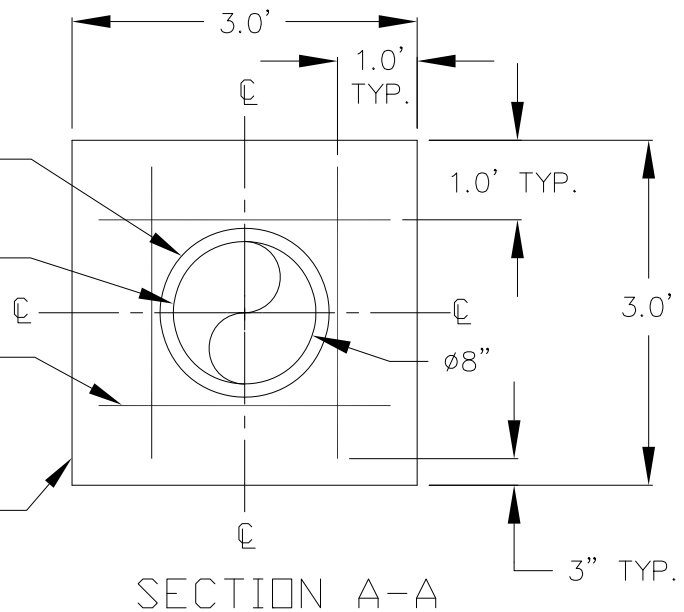

MID SPAN THRUST ANCHOR NOTES:

1. INSTALL MID SPAN THRUST ANCHOR TO PROVIDE TEMPORARY RESTRAINT TO THE END OF EXISTING WATER LINE MAIN, SIZED ACCORDING TO PIPE DIAMETER.
2. INSTALL EBAA SERIES 1100SDB MID SPAN RESTRAINT PER MANUFACTURER'S INSTRUCTIONS.
3. BACKFILL AROUND THRUST ANCHOR SHALL BE TYPE II-A CLASSIFIED FILL COMPACTED TO A MINIMUM OF 95% MAXIMUM DENSITY.
4. PROVIDE FOUR CONTINUOUS #4 REBAR HOOPS IN THRUST ANCHOR. PLACE HOOPS PARALLEL TO HORIZONTAL AND VERTICAL AXIS 2 EACH.
5. CONCRETE SHALL REACH 75% OF 4000 PSI DESIGN MAXIMUM STRENGTH BEFORE PUTTING THRUST BLOCK ANCHOR INTO SERVICE.
6. WHERE NEW PIPE IS USED, CONTRACTOR MAY CONSTRUCT THE THRUST BLOCK AND PIPE ASSEMBLY COMPLETE BEFORE INSTALLING INTO THE WATER SYSTEM.

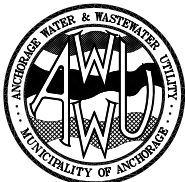

SCALE:
NTS

APPROVED:

REVISED:
1/2015

MID-SPAN THRUST BLOCK

SECTION #
60.02

DETAIL #
60-07

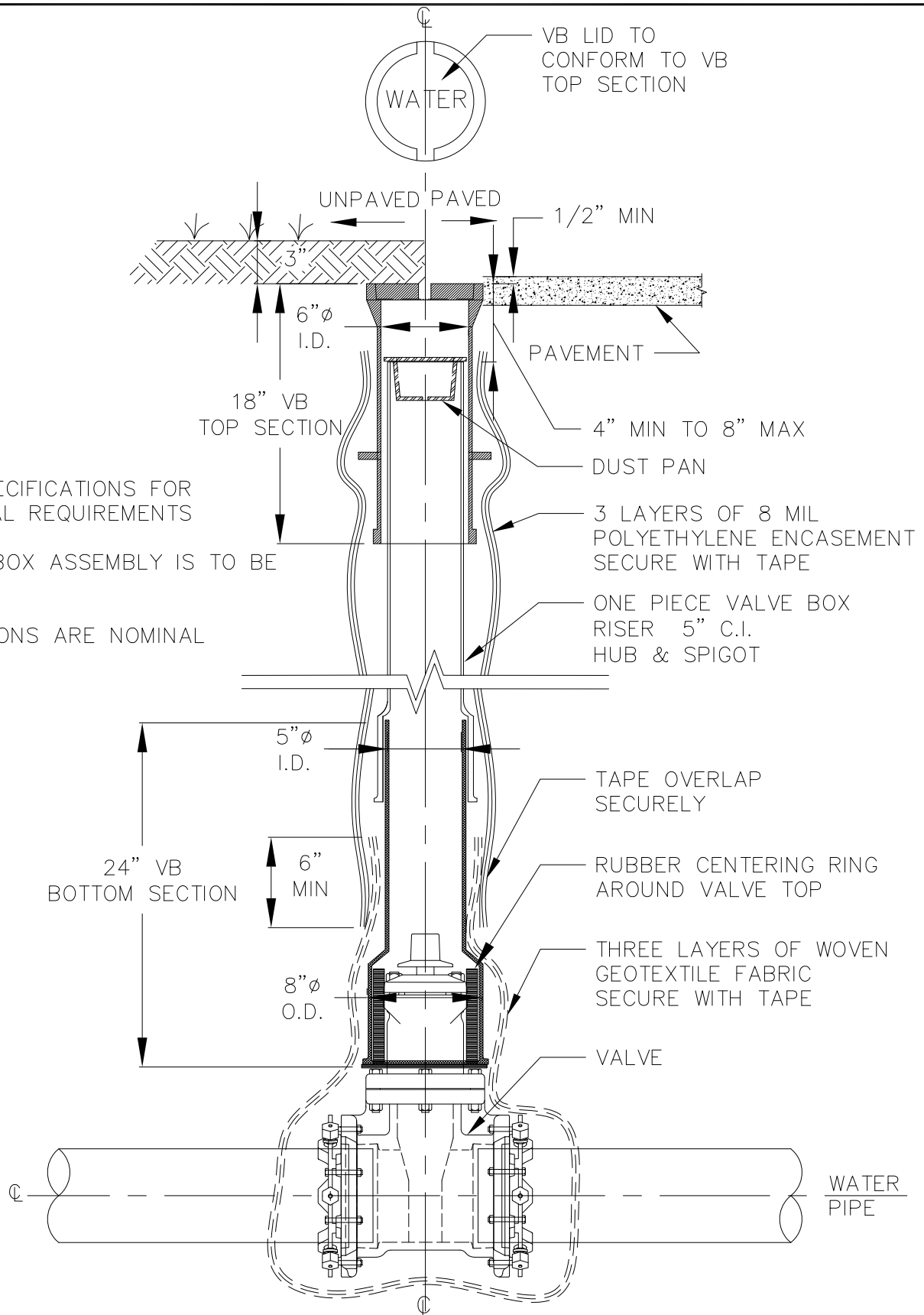

NOTES:

1. SEE SPECIFICATIONS FOR MATERIAL REQUIREMENTS
2. VALVE BOX ASSEMBLY IS TO BE PLUMB
3. DIMENSIONS ARE NOMINAL

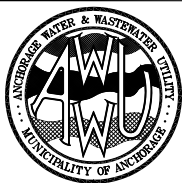

SCALE:
NTS

APPROVED:

REVISED:
1/2015

TYPICAL VALVE BOX (VB)

SECTION #
60.03

DETAIL #
60-08

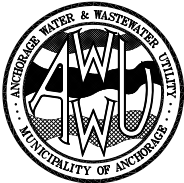
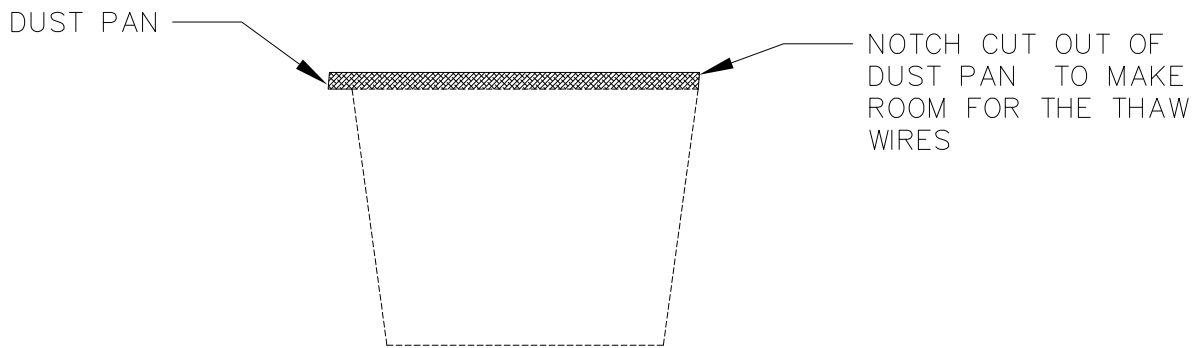
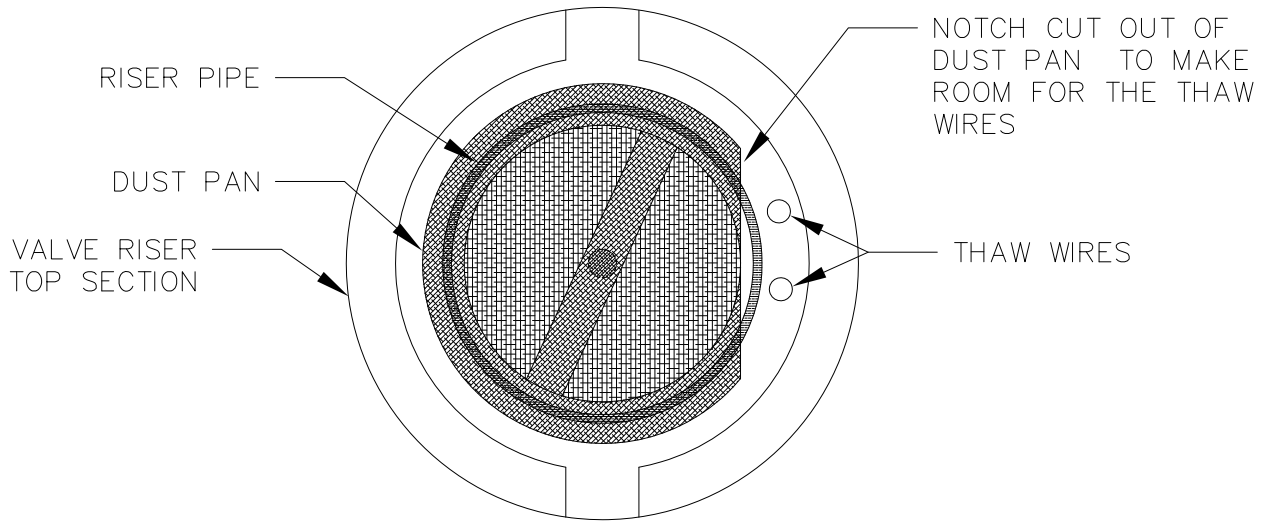

SCALE:
NTS

APPROVED:

REVISED:
1/2015

DUST PAN WITH THAW WIRES

SECTION #
60.03

DETAIL #
60-09

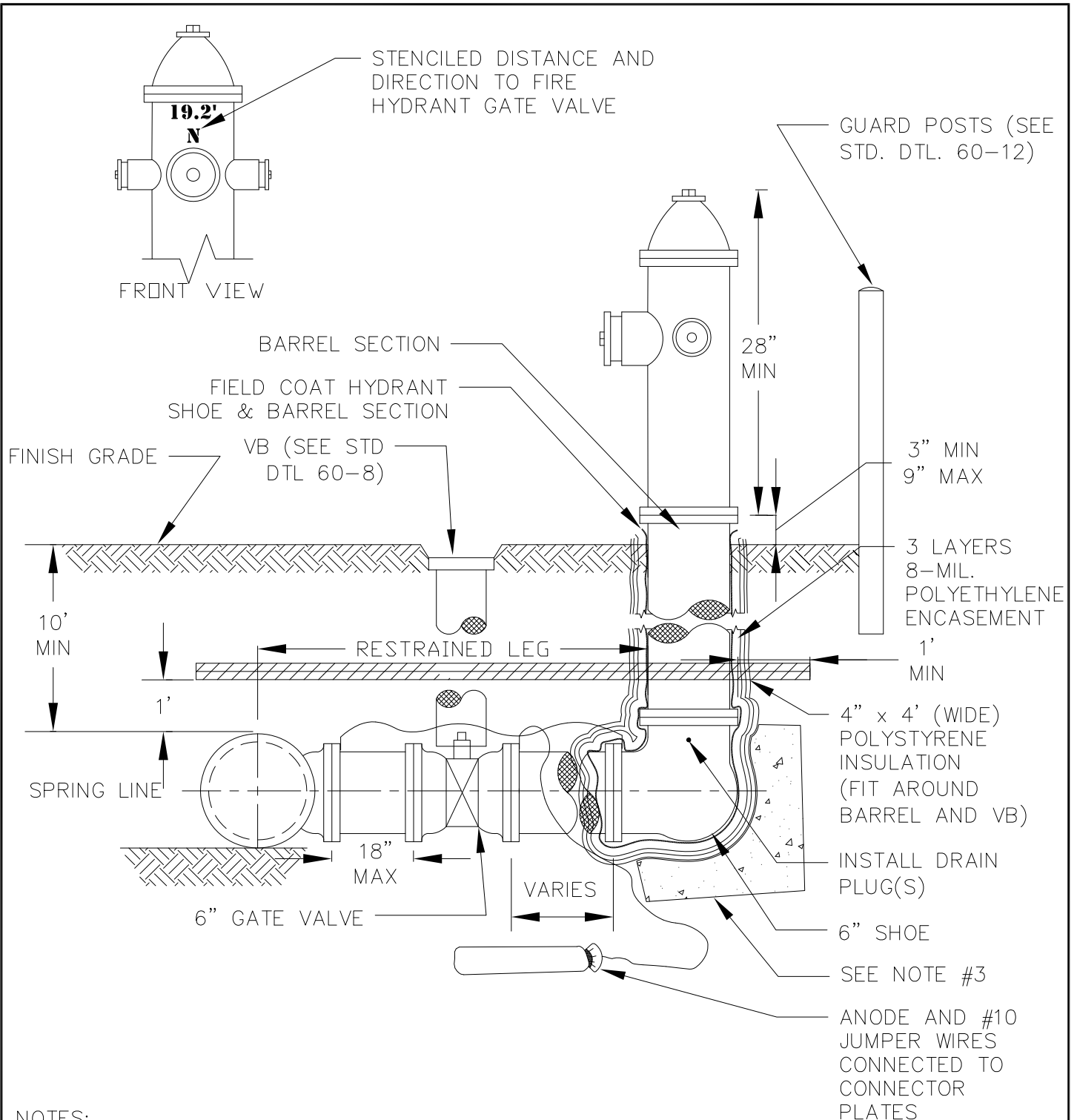

NOTES:

1. HYDRANT BARREL SHALL BE INSTALLED PLUMB AND THE LEG SHALL BE LEVEL.
2. ALL BACKFILL MATERIAL WITHIN 3 FEET AROUND HYDRANT BARREL SHALL BE NFS.
3. ALL PVC C-900 HYDRANT LEG SHALL HAVE THRUST BLOCKS (SEE MASS DETAIL 60.06).
4. DUCTILE IRON HYDRANT LEGS DO NOT REQUIRE A THRUST BLOCK

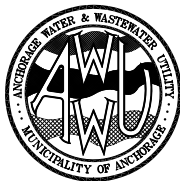

SCALE:
NTS

APPROVED:

REVISED:
1/2015

SINGLE PUMPER "L" BASE FIRE HYDRANT ASSEMBLY

SECTION #
60.04

DETAIL #
60-10

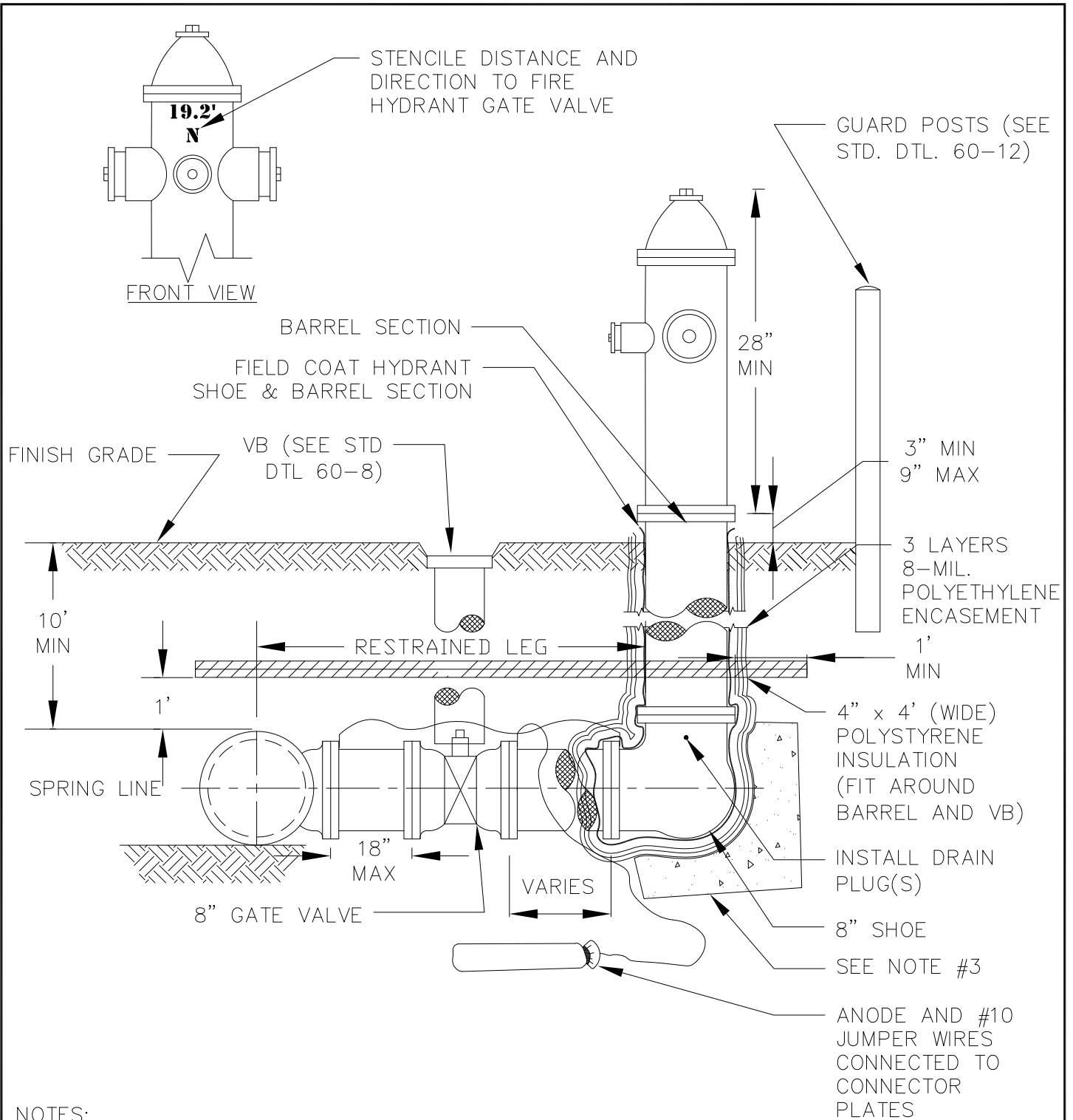

NOTES:

1. HYDRANT BARREL SHALL BE INSTALLED PLUMB AND THE LEG SHALL BE LEVEL.
2. ALL BACKFILL MATERIAL WITHIN 3 FEET AROUND HYDRANT BARREL SHALL BE NFS.
3. ALL PVC C-900 HYDRANT LEG SHALL HAVE THRUST BLOCKS (SEE MASS DETAIL 60.06).



SCALE:
NTS

APPROVED:

REVISED:
1/2015

**DOUBLE PUMPER "L" BASE
FIRE HYDRANT ASSEMBLY**

SECTION #
60.04

DETAIL #
60-11

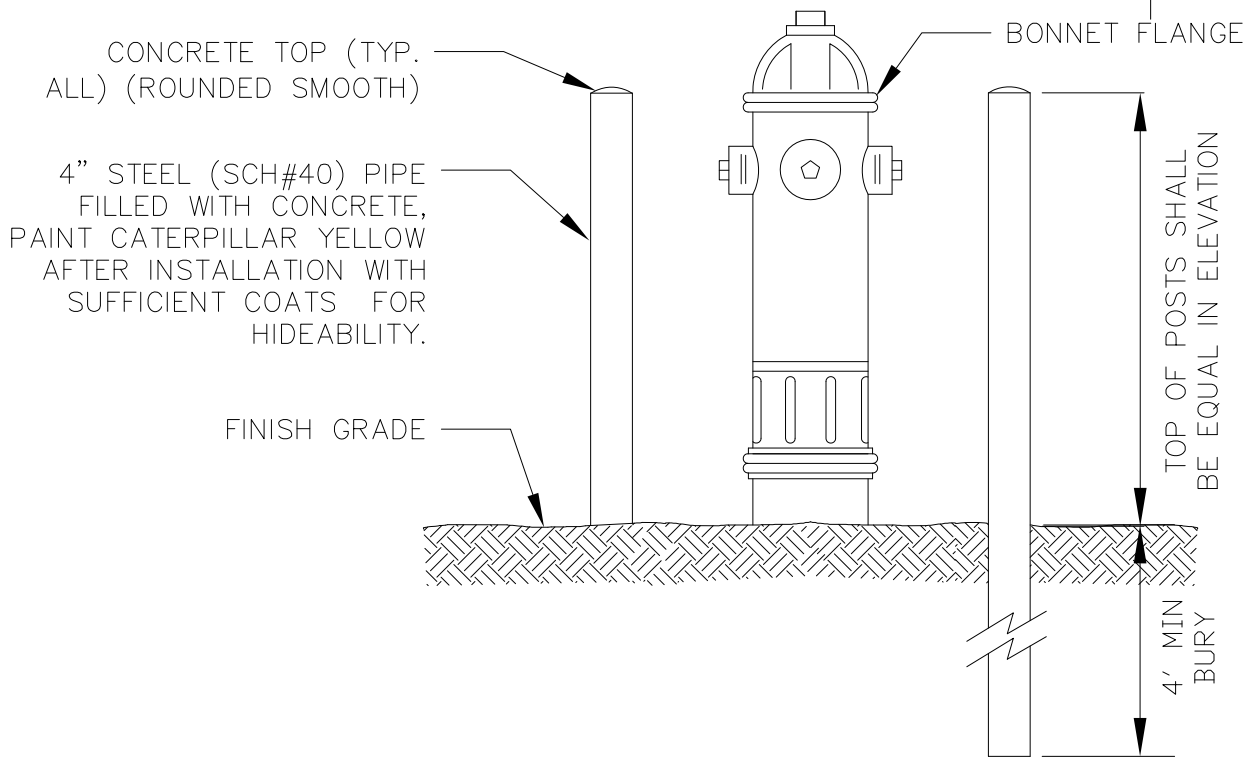
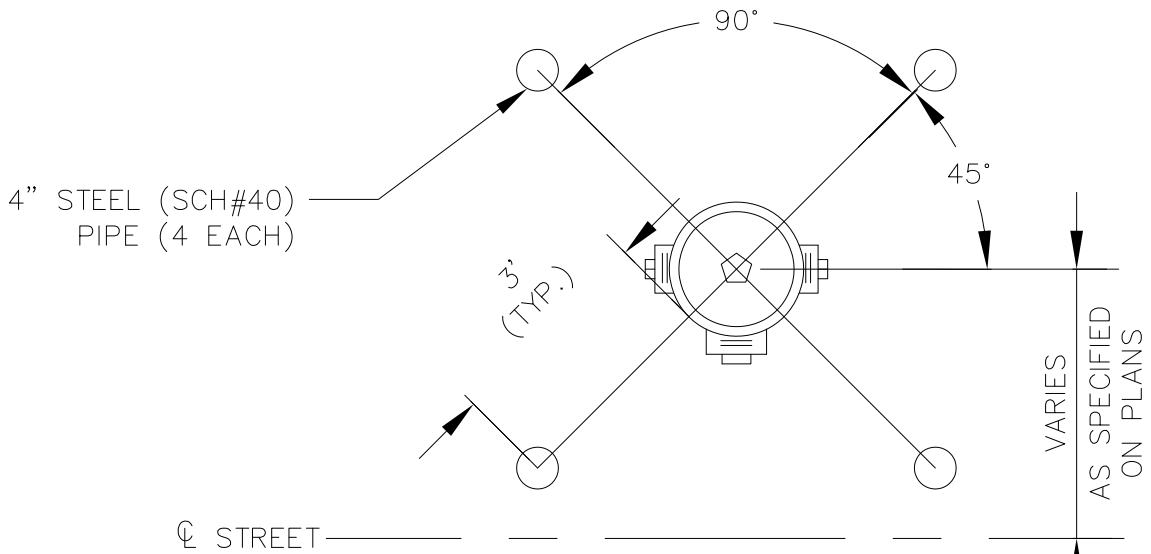

- NOTES:
1. GUARD POSTS WILL BE FURNISHED & INSTALLED BY THE CONTRACTOR AND APPROVED BY THE ENGINEER.
 2. GUARD POSTS SHALL BE INSTALLED PLUMB AND LOCATED TO ALLOW UNRESTRICTED ACCESS TO PUMPER AND HOSE CONNECTIONS.



SCALE:
NTS

APPROVED:

REVISED:
1/2015

FIRE HYDRANT GUARD POSTS

SECTION #
60.04

DETAIL #
60-12

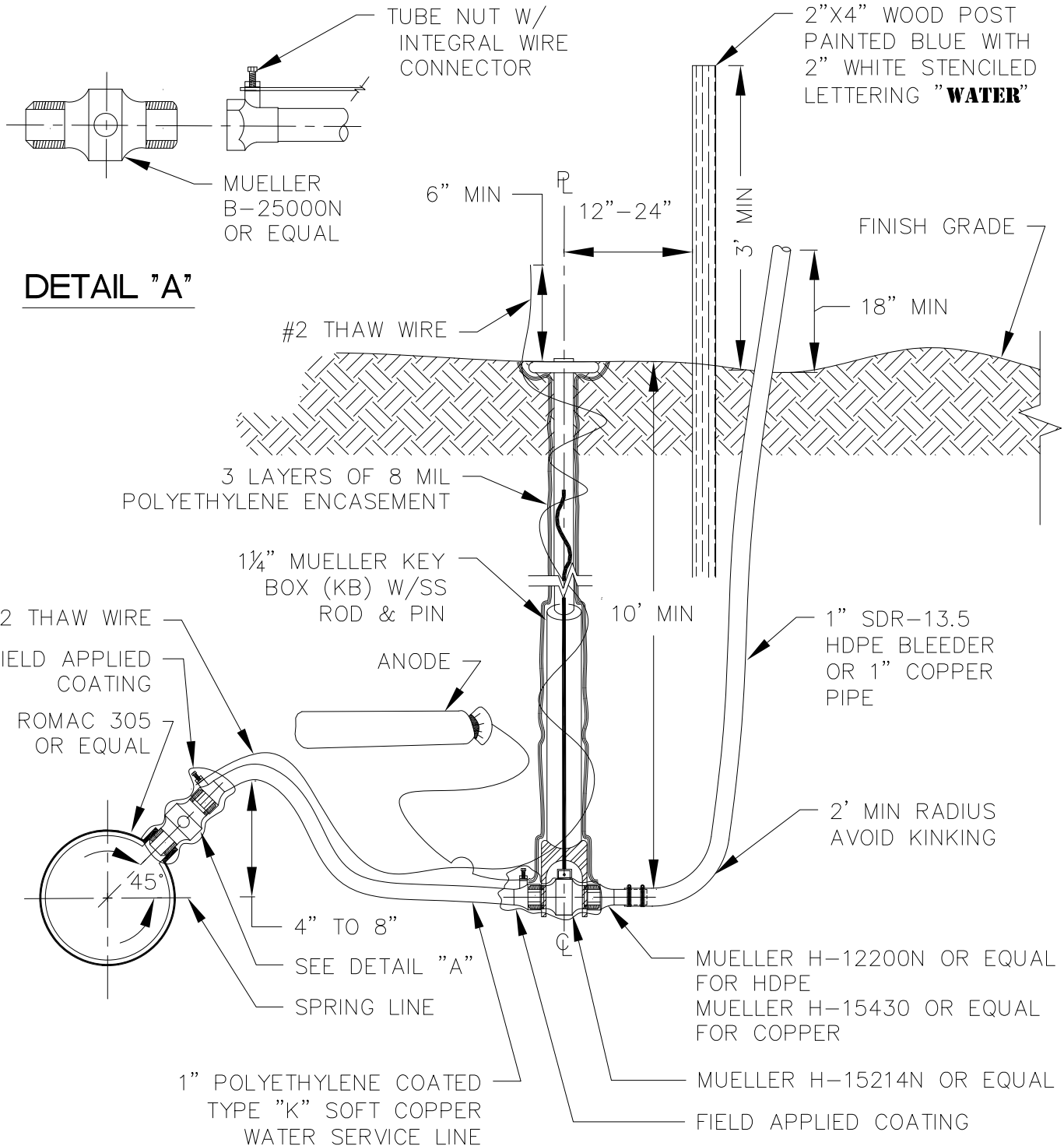

NOTES:

1. STAINLESS STEEL (SS) WRAP AROUND SERVICE SADDLE TO BE USED ON ALL TAPS. PVC TAPS ARE TO BE DONE IN ACCORDANCE WITH THE UTILITY COMPANY PVC TAPPING GUIDE.
2. THAW WIRE IS TO BE #2 GAUGE HMWPE INSULATED COPPER WIRE THAT IS LAID PARALLEL TO THE SERVICE LINE WITHOUT CONTACTING THE SERVICE LINE.

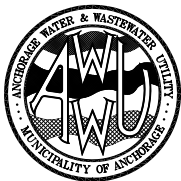

SCALE:
NTS

APPROVED:

REVISED:
1/2015

1" WATER SERVICE CONNECT

SECTION #
60.05

DETAIL #
60-13

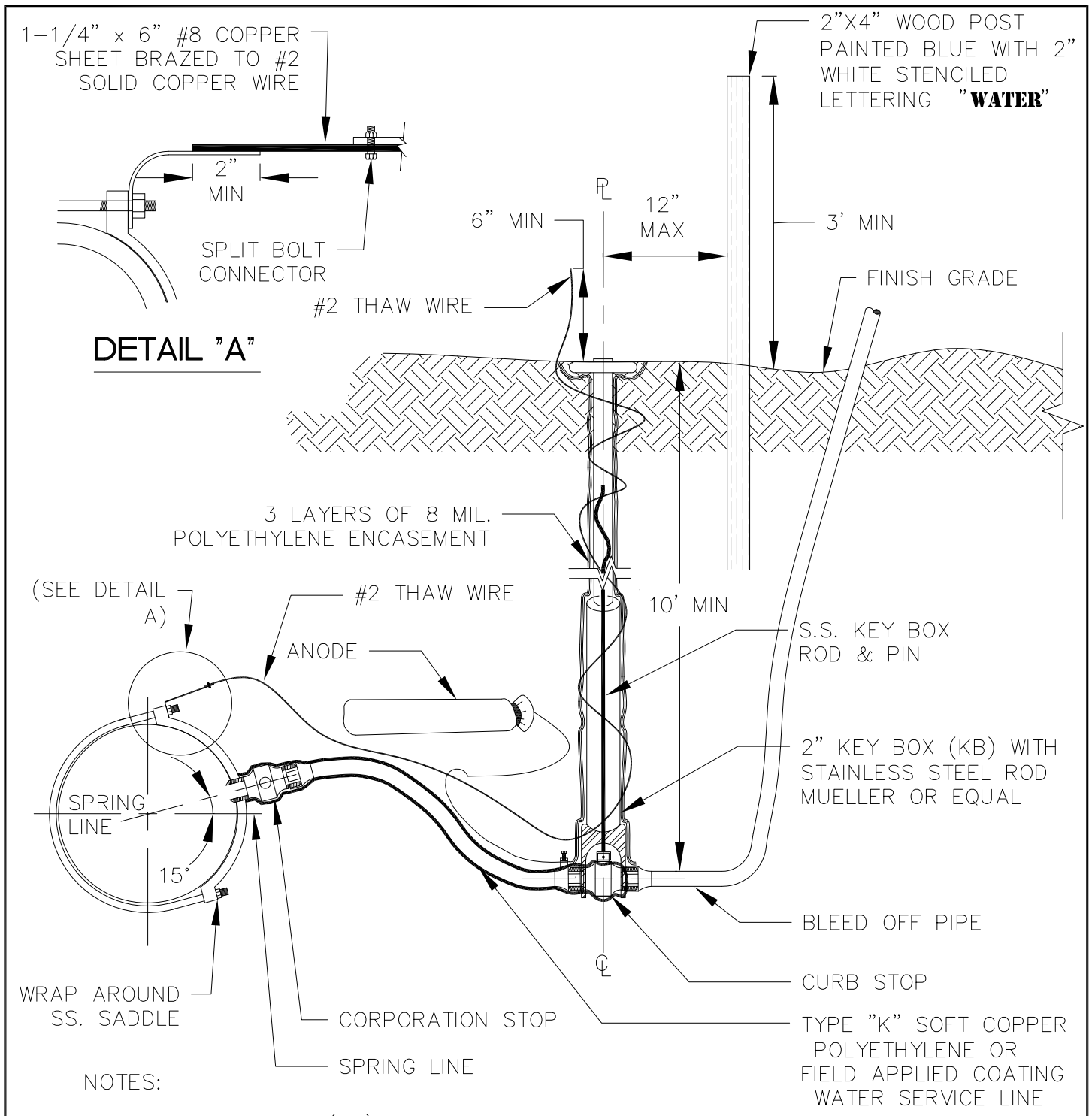

NOTES:

1. STAINLESS STEEL (SS) WRAP AROUND SERVICE SADDLE TO BE USED ON ALL TAPS. PVC TAPS MUST BE A MINIMUM OF 3' APART
2. THAW WIRE IS TO BE #2 GAUGE HMWPE INSULATED COPPER WIRE THAT IS LAID PARALLEL TO THE SERVICE LINE WITHOUT CONTACTING THE SERVICE LINE .



SCALE:
NTS

APPROVED:

REVISED:
1/2015

WATER SERVICE CONNECT

1-1/2" AND 2"

SECTION #
60.05

DETAIL #
60-14

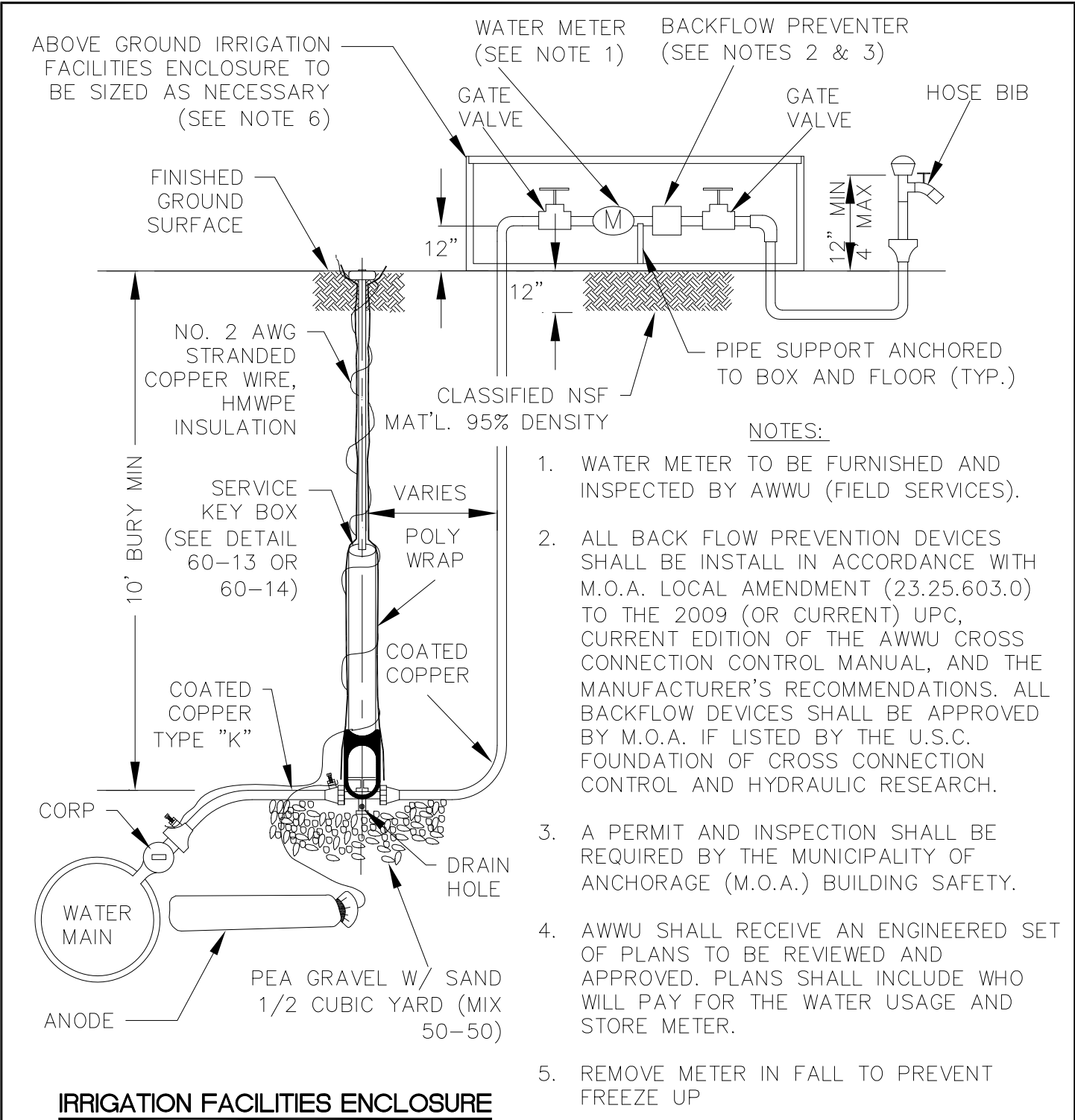

IRRIGATION FACILITIES ENCLOSURE

6. FOR SECURITY AND PROTECTION, IT IS RECOMMENDED THAT THE ENCLOSURE BE FABRICATED WITH 1-1/2"x 1-1/2" ANGLE IRON (FRAME) COVERED W/ FLAT EXPANDED METAL (MESH) PRIMED AND PAINTED. ENCLOSURE SHALL BE SIZED TO ENCLOSE ALL ABOVE FINISH GRADE APPURTENANCES AND SHALL PROVIDE ADEQUATE DRAINAGE TO KEEP THE BACKFLOE PREVENTER FROM BECOMING SUBMERGED.

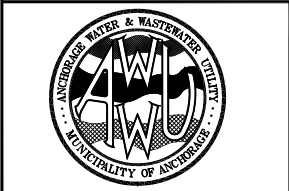

SCALE:
NTS

APPROVED:

REVISED:
1/2015

IRRIGATION SYSTEM

SECTION #
60.05

DETAIL #
60-15

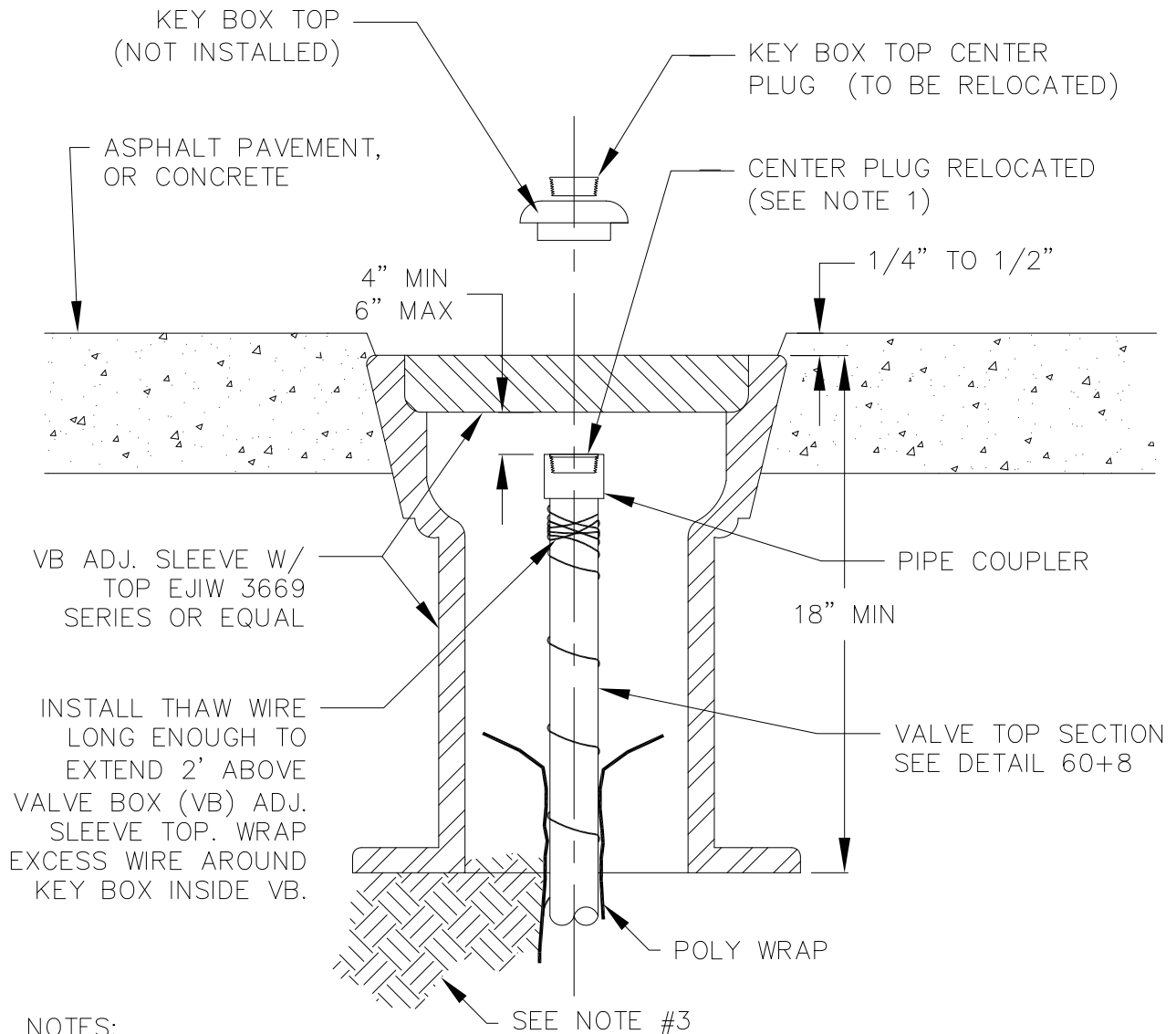

NOTES:

1. REMOVE KEY BOX TOP AND INSTALL PIPE COUPLING ON STANDARD KEY BOX, REMOVE CENTER PLUG FROM KEY BOX TOP AND INSTALL INTO TOP OF PIPE COUPLER.
2. TYPICAL INSTALLATION WHEN KEY BOX FALLS WITHIN ASPHALT PAVEMENT, CONCRETE WALK OR DRIVEWAY.
3. ALL BACKFILL MATERIAL AROUND VALVE BOX SHALL BE NFS AND COMPACTED TO 95% MAX. DENSITY.

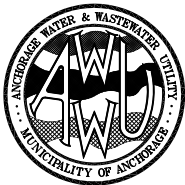

SCALE:
NTS

APPROVED:

REVISED:
1/2015

ADJUST SERVICE KEY BOX

SECTION #
60.05

DETAIL #
60-16

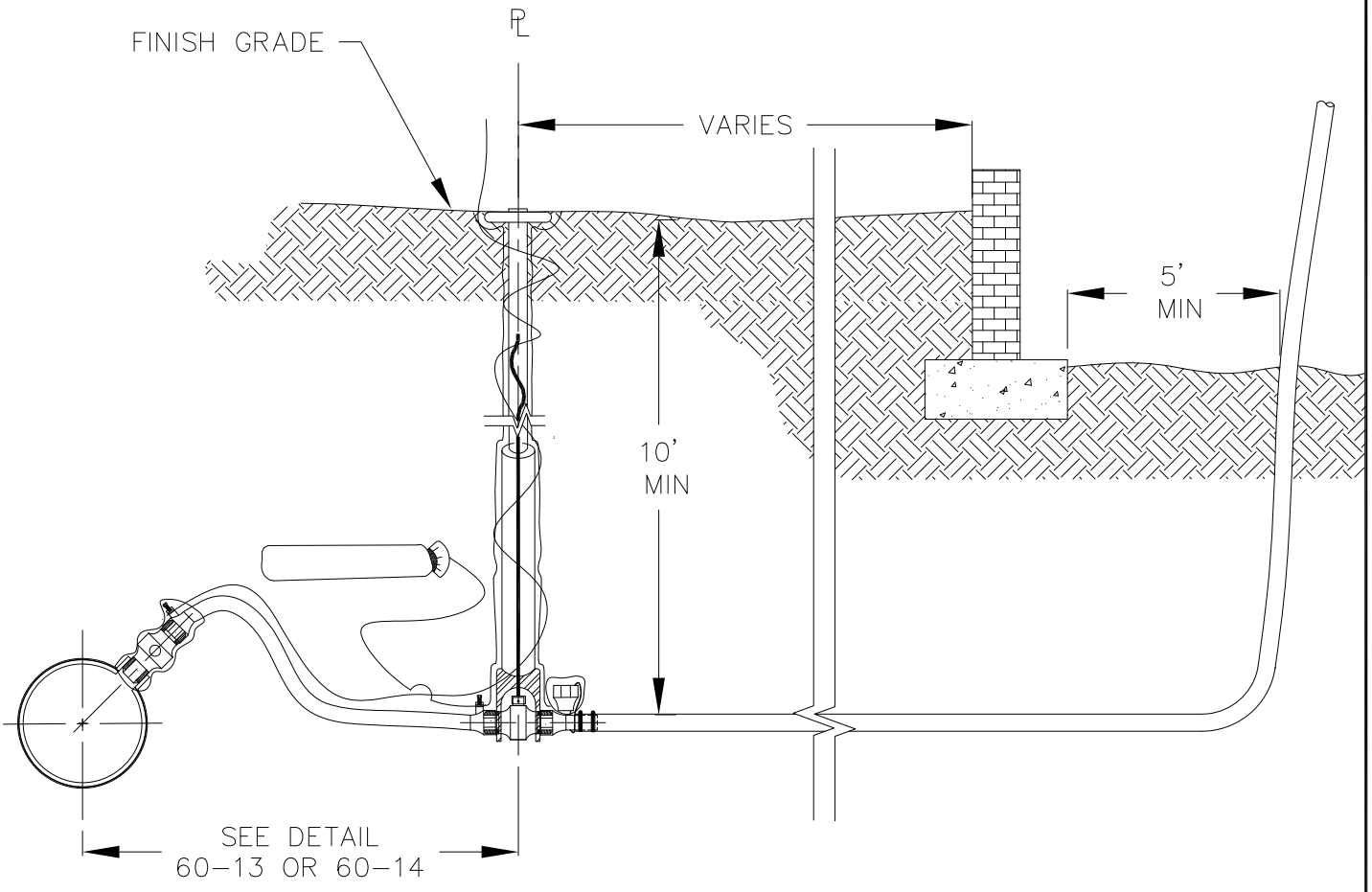

SCALE:
NTS

APPROVED:

REVISED:
1/2015

SMALL DIAMETER WATER SERVICE EXTENSION UNDER FOUNDATION

SECTION #
60.05

DETAIL #
60-17

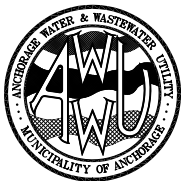
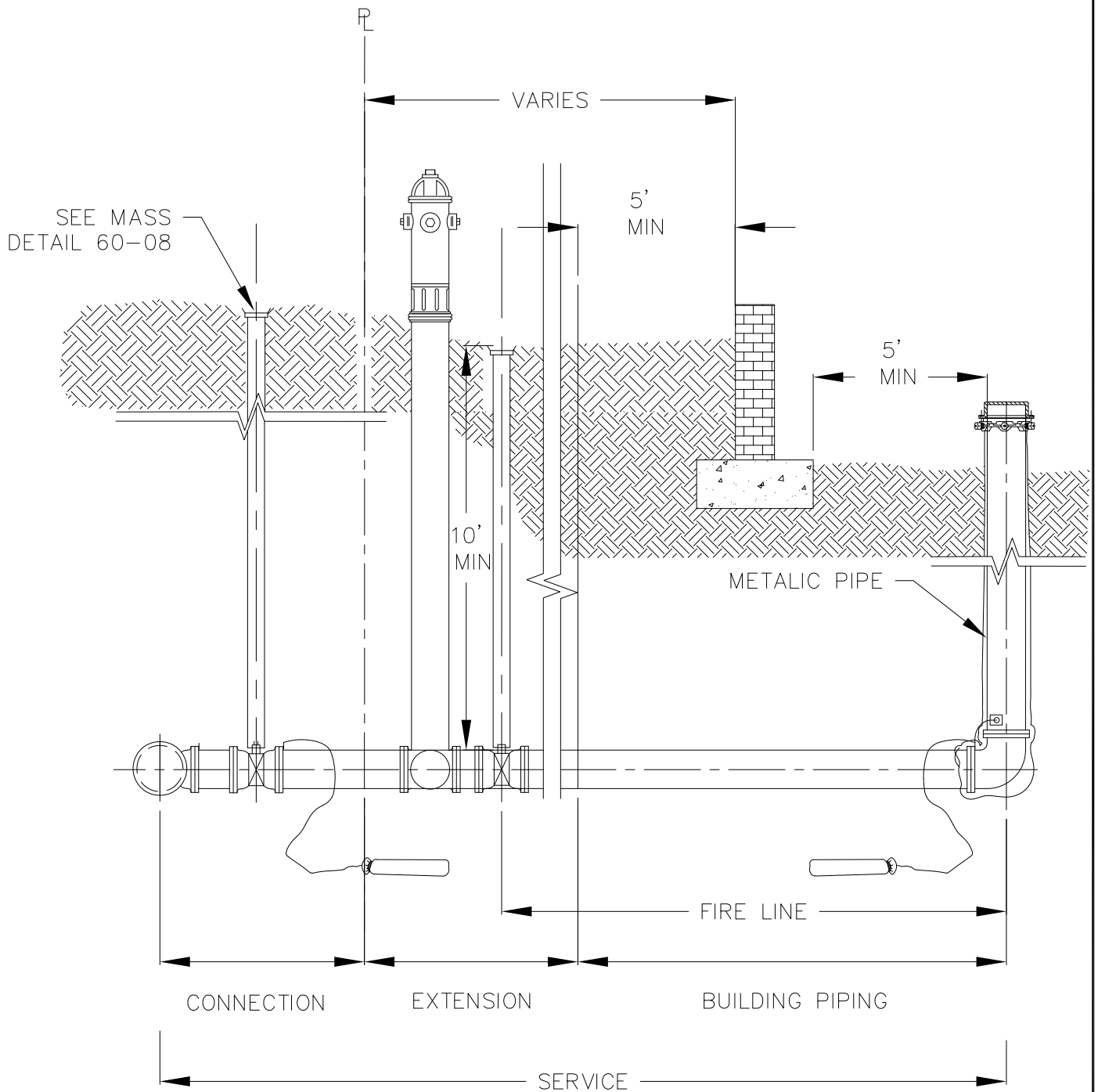

SCALE:
NTS

APPROVED:

REVISED:
1/2015

LARGE DIAMETER WATER SERVICE UNDER FOUNDATION

SECTION #
60.05

DETAIL #
60-18

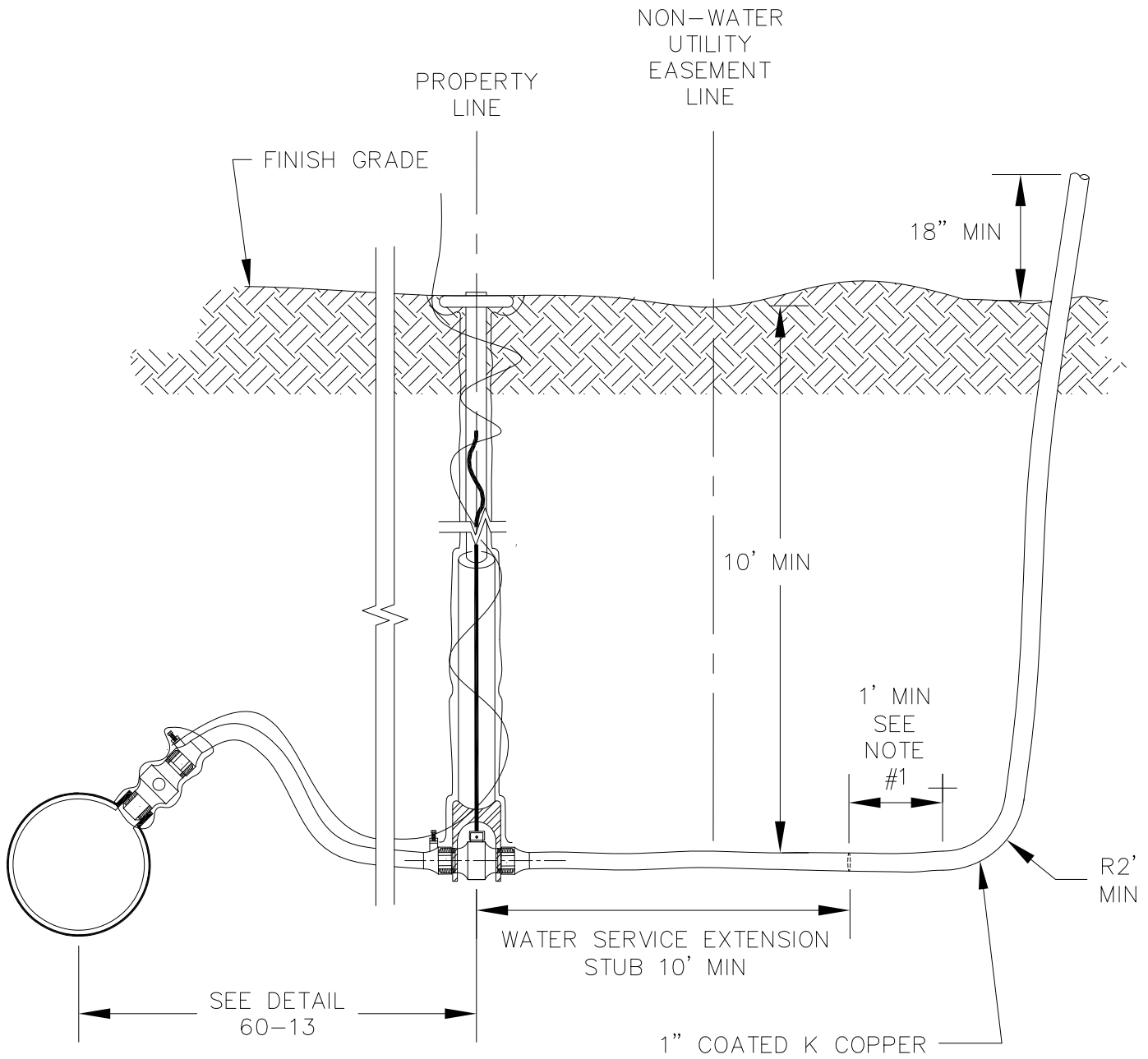

NOTES:

1. EXTENDING FROM THE EXTENSION STUB IS TO BE ACCOMPLISHED BY MAKING A CLEAN CUT ONE FOOT FROM THE BEGINNING OF THE VERTICAL BEND.
2. THE EXISTING CONNECTION AND EXTENSION STUB ARE TO BE FLUSHED PRIOR TO EXTENDING THE EXTENSION.

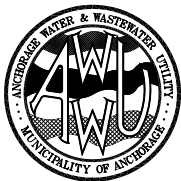

SCALE:
NTS

APPROVED:

REVISED:
1/2015

WATER SERVICE EXTENSION STUB

SECTION #
60.05

DETAIL #
60-19

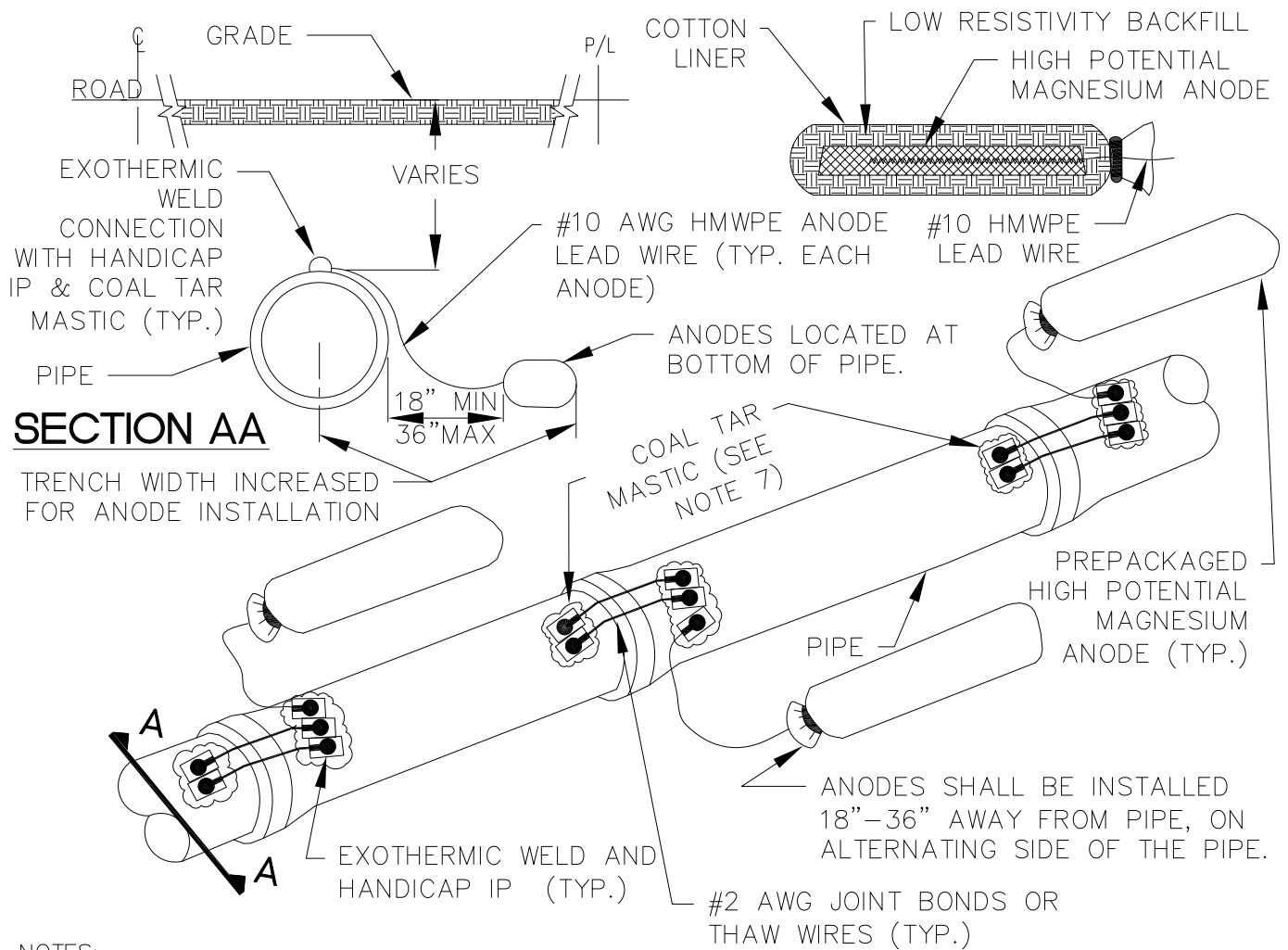

NOTES:

1. HIGH POTENTIAL MAGNESIUM ANODES SHALL BE PREPACKAGED IN A CLOTH BAG WITH A BACKFILL MIXTURE OF 75% GYPSUM, 20% BENTONITE AND 5% SODIUM SULFATE. THE ANODES SHALL HAVE A 20 lb. BARE WEIGHT AND APPROXIMATELY 70 lb. PACKAGED WEIGHT.
2. ANODES SHALL BE INSTALLED AT A MAXIMUM SPACING OF 18 FEET OF BURIED PIPE BETWEEN ANODES. AN ANODE IS REQUIRED ON THE FIRST AND LAST JOINT OF PIPE. AN ADDITIONAL TWO (2) ANODES MUST BE INSTALLED ON THE EXISTING TIE-IN PIPE.
3. CONTRACTOR SHALL PROVIDE COORDINATES OR PIPE STATIONING FOR EACH ANODE INSTALLED.
4. TWO #2 AWG JOINT BOND WIRES ARE REQUIRED, WHEN ANODE INSTALLATIONS ARE REQUIRED.
5. ALL CABLES SHALL BE SINGLE CONDUCTOR, STRANDED COPPER, WITH TYPE HMWPE INSULATION RATED FOR 600 VOLTS.
6. SPLIT-BOLT CONNECTIONS SHALL NOT BE ALLOWED ON ANY UNDERGROUND CONDUCTORS. IF SPLICES ARE REQUIRED, COMPRESSION CONNECTIONS (BURNDY OR APPROVED EQUAL) SHALL BE USED. COMPRESSION CONNECTIONS SHALL BE SEALED WITH A HEAT SHRINK SLEEVE RATED FOR BELOW GRADE USE.
7. EXOTHERMIC WELDS SHALL BE MADE IN STRICT ACCORDANCE WITH THE MANUFACTURER'S RECOMMENDATIONS (NOTE: COPPER CONDUCTOR SLEEVES ARE REQUIRED FOR #10 WIRE BY SOME MANUFACTURERS). THE EXOTHERMIC WELD AREA SHALL BE COATED WITH HANDICAP IP OR EQUAL AND ANY BASE METAL EXPOSED AFTER INSTALLATION OF HANDICAP IP MUST BE COATED WITH COAL TAR MASTIC.
8. AT FIRE HYDRANT LOCATIONS, INSTALL ONE ANODE (18"-36" AWAY FROM THE PIPE) AT THE MIDPOINT BETWEEN THE TEE FROM THE MAIN LINE PIPE AND THE HYDRANT SHOE.

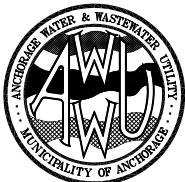

SCALE:
NTS
APPROVED:
REVISID:
1/2015

ANODE DETAIL

SECTION #
60.06

DETAIL #
60-20

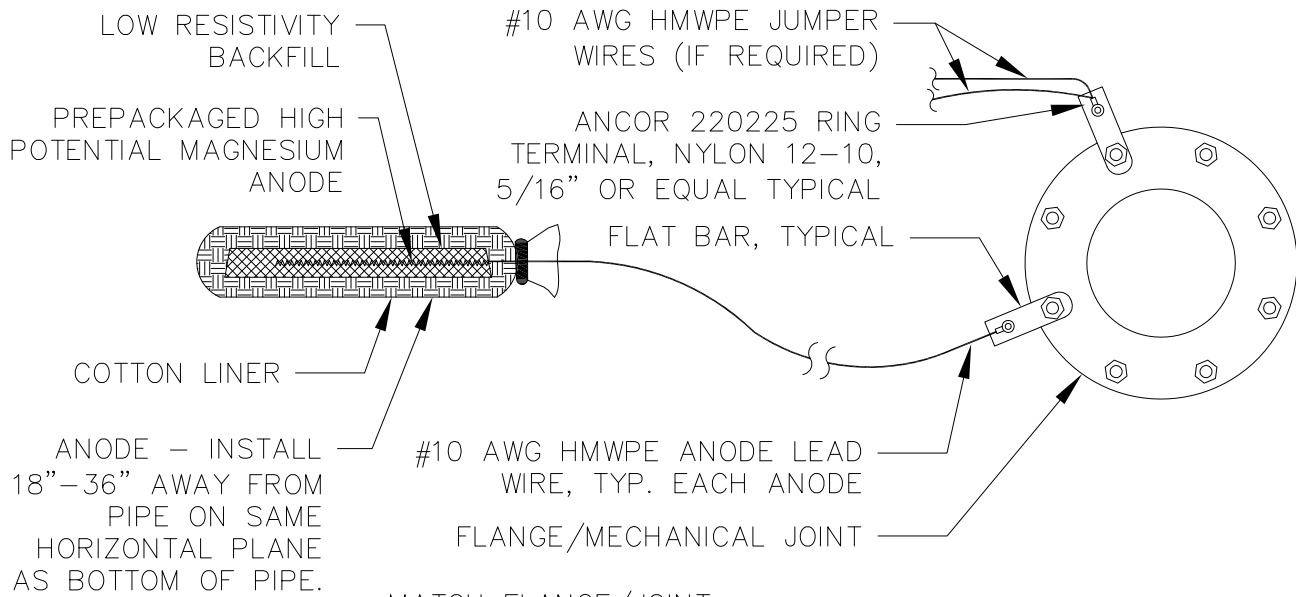

MATCH FLANGE/JOINT
BOLT HOLE DIAMETER

2½" x 6" FLAT BAR
STAINLESS STEEL (TYPE 316)
MATERIAL ⅛" THICKNESS

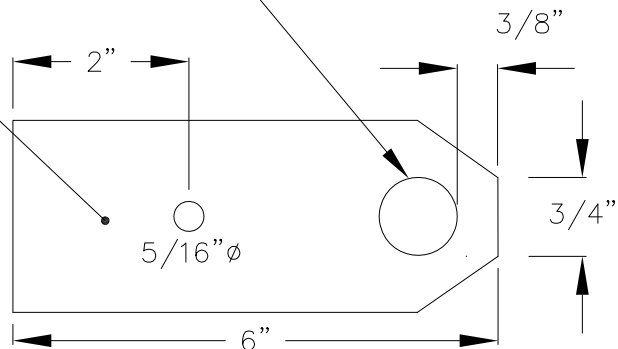

ANODE WIRE CONNECTION NOTES:

1. CONTRACTOR TO FABRICATE FLAT BAR.
2. INSTALL FLAT BAR ON BODY SIDE OF FLANGE OR MECHANICAL JOINT. REMOVE COATING AT THE FLAT BAR LOCATION PRIOR TO INSTALLATION. METAL TO METAL CONTACT IS REQUIRED. REPAIR VISIBLE COATING DAMAGE WITH DENSYL TAPE AND PRIMER.
3. CONNECT WIRE WITH COMPRESSION RING CONNECTOR AND 1/4"Ø x 1" STAINLESS STEEL BOLT (TYPE 316) WITH WASHER AND SELF LOCKING NUT.
4. TWO #10 AWG HMWPE JUMPER WIRES REQUIRED TO CONNECT EACH VALVE/HYDRANT.
5. WRAP ELECTRICAL INSULATION TAPE AROUND RING CONNECTOR AND BOND STRAP (WIRE END ONLY). DENSYL TAPE OR APPROVED EQUAL.
6. WRAP ELECTRICAL INSULATION TAPE A MINIMUM OF 3" DOWN ON WIRE INSULATION TO ENCAPSULATE CONNECTION.

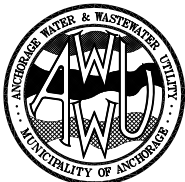

SCALE:
NTS
APPROVED:
REVISID:
1/2015

ANODE WIRE CONNECTION

SECTION #
60.06

DETAIL #
60-21

