

**MUNICIPALITY OF ANCHORAGE
STANDARD SPECIFICATIONS**

**DIVISION 55
STORM DRAIN SYSTEMS**

**STANDARD CONSTRUCTION SPECIFICATIONS
FOR STORM DRAIN SYSTEMS
DIVISION 55
INDEX**

SECTION 55.01	GENERAL	1
Article 1.1	Scope of Work.....	1
Article 1.2	Applicable Standards	1
Article 1.3	Surveys	2
Article 1.4	Concrete and Mortar	2
Article 1.5	Payment - General	2
SECTION 55.02	FURNISH AND INSTALL PIPE	3
Article 2.1	General	3
Article 2.2	Material	3
Article 2.3	Construction	7
Article 2.4	Measurement	9
Article 2.5	Basis of Payment	9
SECTION 55.03	SUBDRAINS AND PERFORATED STORM MAINS	10
Article 3.1	General	10
Article 3.2	Material	10
Article 3.3	Construction	10
Article 3.4	Measurement	10
Article 3.5	Basis of Payment	11
SECTION 55.04	MODIFICATIONS TO EXISTING MANHOLES OR CATCH BASINS	12
Article 4.1	General	12
Article 4.2	Materials	12
Article 4.3	Construction	12
Article 4.4	Measurement	13
Article 4.5	Basis of Payment	13
SECTION 55.05	MANHOLES AND CATCH BASIN MANHOLES	14
Article 5.1	General	14
Article 5.2	Material	14
Article 5.3	Construction	15
Article 5.4	Measurement	16
Article 5.5	Basis of Payment	16
SECTION 55.06	WATERTIGHT MANHOLE FRAMES AND COVER.....	17
Article 6.1	General	17
Article 6.2	Material	17
Article 6.3	Construction	17
Article 6.4	Measurement	17
Article 6.5	Basis of Payment	17

SECTION 55.07	ADJUST MANHOLE CONE, MANHOLE RING, OR CATCH BASIN TO FINISH GRADE	18
Article 7.1	General	18
Article 7.2	Material	18
Article 7.3	Construction	18
Article 7.4	Measurement	19
Article 7.5	Basis of Payment	19
SECTION 55.08	THIS SECTION INTENTIONALLY LEFT BLANK.....	20
SECTION 55.09	CONSTRUCT CATCH BASIN.....	21
Article 9.1	General	21
Article 9.2	Material	21
Article 9.3	Construction	21
Article 9.4	Measurement	21
Article 9.5	Basis of Payment	21
SECTION 55.10	RELOCATE CATCH BASIN OR CATCH BASIN MANHOLE.....	22
Article 10.1	General	22
Article 10.2	Material	22
Article 10.3	Construction	22
Article 10.4	Measurement	22
Article 10.5	Basis of Payment	22
SECTION 55.11	REMOVE MANHOLE OR CATCH BASIN	23
Article 11.1	General	23
Article 11.2	Construction	23
Article 11.3	Measurement	23
Article 11.4	Basis of Payment	23
SECTION 55.12	THIS SECTION INTENTIONALLY LEFT BLANK.....	24
SECTION 55.13	ABANDON CATCH BASIN LEAD	25
Article 13.1	General	25
Article 13.2	Materials	25
Article 13.3	Construction	25
Article 13.4	Measurement	25
Article 13.5	Basis of Payment	25
SECTION 55.14	CONSTRUCT STORM DRAIN CLEANOUT	26
Article 14.1	General	26
Article 14.2	Material	26
Article 14.3	Measurement	26
Article 14.4	Basis of Payment	26
SECTION 55.15	ADJUST STORM DRAIN CLEANOUT TO FINISH GRADE	27
Article 15.1	General	27
Article 15.2	Material	27
Article 15.3	Construction	27
Article 15.4	Measurement	27

Article 15.5	Basis of Payment	27
SECTION 55.16	CONSTRUCT DROP CONNECTION	28
Article 16.1	General	28
Article 16.2	Material	28
Article 16.3	Construction	28
Article 16.4	Measurement	28
Article 16.5	Basis of Payment	28
SECTION 55.17	FLUME DOWNDRAIN	29
Article 17.1	General	29
Article 17.2	Materials	29
Article 17.3	Construction	29
Article 17.4	Measurement	29
Article 17.5	Basis of Payment	29
SECTION 55.18	FOOTING DRAIN SERVICES.....	30
Article 18.1	General	30
Article 18.2	Material	30
Article 18.3	Construction	30
Article 18.4	Measurement	30
Article 18.5	Basis of Payment	30
SECTION 55.19	CONSTRUCT OPEN DITCH	31
Article 19.1	General	31
Article 19.2	Construction	31
Article 19.3	Measurement	31
Article 19.4	Basis of Payment	31
SECTION 55.20	CULVERT	32
Article 20.1	General	32
Article 20.2	Material	32
Article 20.3	Construction	32
Article 20.4	Measurement	32
Article 20.5	Basis of Payment	32
SECTION 55.21	FIN DRAIN	33
Article 21.1	General	33
Article 21.2	Materials	33
Article 21.3	Construction	33
Article 21.4	Measurement	33
Article 21.5	Basis of Payment	34
SECTION 55.22	OIL AND GRIT SEPARATOR	35
Article 22.1	General	35
Article 22.2	Materials	35
Article 22.3	Construction	35
Article 22.4	Measurement	35
Article 22.5	Basis of Payment	36

SECTION 55.23	UNDERGROUND DETENTION AND INFILTRATION SYSTEMS.....	37
Article 23.1	General	37
Article 23.2	Related Standards	37
Article 23.3	Materials	37
Article 23.4	Construction	37
Article 23.5	Measurement	38
Article 23.6	Basis of Payment	38
SECTION 55.24	THIS SECTION INTENTIONALLY LEFT BLANK.....	39
SECTION 55.25	STORM DRAIN CLOSED CIRCUIT TELEVISION INSPECTIONS.....	40
Article 25.1	General	40
Article 25.2	Submittals	40
Article 25.3	Material	40
Article 25.4	Construction	41
Article 25.5	Measurement	44
Article 25.6	Basis of Payment	44
SECTION 55.26	CURED IN PLACE PIPE (CIPP) LINING	45
Article 26.1	Description	45
Article 26.2	Submittals	45
Article 26.3	Materials	46
Article 26.4	Construction	47
Article 26.5	Work Incidental to CIPP	51
Article 26.6	Measurement	53
Article 26.7	Basis of Payment	53

**STANDARD CONSTRUCTION SPECIFICATIONS
FOR STORM DRAIN SYSTEMS
DIVISION 55**

SECTION 55.01 GENERAL

Article 1.1 Scope of Work

The Work covered by these Specifications consists of providing all plant, labor, equipment, supplies, transportation, handling, storage, and performance of all operations necessary to complete the construction for the pipe laying, jointing, and testing of storm drain systems and culverts.

Requirements for earthwork including trench excavation and backfill are specified in Division 20 - Earthwork.

Article 1.2 Applicable Standards

The latest revision of the following standards of the American Society for Testing and Materials (ASTM), the American Association of State Highway and Transportation Officials (AASHTO), and the American Water Works Association (AWWA) are hereby made part of this Specification.

ASTM A48 (AASHTO M-105)	Standard Specifications for Gray Iron Castings
ASTM C76	Specification for Reinforced Concrete
ASTM C150	Specification for Portland Cement
ASTM C478 (AASHTO M-199)	Specification for Precast Reinforced Concrete Manhole Sections
ASTM C990	Specification for Joints for Concrete Pipe, Manholes, and Precast Box Sections Using Preformed Flexible Joint Sealants
ASTM D1248	Polyethylene Plastics Molding and Extrusion Materials, Type III, High Density
ASTM D2321	Standard Practice for Underground Installation of Thermoplastic Pipe
ASTM D3035	Polyethylene Plastic Pipe (SDR-PR) Based on Controlled Outside Diameter
ASTM D3350	Polyethylene Plastics and Fittings Materials
ASTM F2648	2 to 60 inch Corrugated Polyethylene Pipe & Fittings
AASHTO M-36	Corrugated Steel Pipe & Fittings
AASHTO M-45	Sand for Cement Mortar
AASHTO M-190	Bituminous Coating of CMP
AASHTO M-196	Corrugated Aluminum Pipe & Fittings

AASHTO M-245	Precoated Galvanized Steel Culverts and Underdrains
AASHTO M-246	Precoated Galvanized Steel Sheets for Culverts and Underdrains
AASHTO M-274	Corrugated Aluminized Pipe and Fittings
AASHTO M-252	Corrugated Polyethylene Pipe 3"-10" diameter
AASHTO M-294	Corrugated Polyethylene Pipe, 12" diameter and larger
AASHTO M-306	Drainage, Sewer, Utility, and Related Castings

Article 1.3 Surveys

The Contractor shall layout in the field the alignment and grade of Work to be done under the Contract. The Contractor shall be responsible for the preservation of all line stakes, grade stakes, and hubs. In the event of their loss or destruction, the Contractor shall be responsible for their proper replacement. The line and grade for pipes shall be given from reference hubs offset from each manhole or cleanout. The Contractor shall be responsible for the transfer of the control points from the reference hubs to such hubs or batter boards as needed for the prosecution of the Work.

All survey work shall adhere to Division 65 – Construction Survey.

Article 1.4 Concrete and Mortar

A. Miscellaneous Concrete

All concrete used in the construction of storm drain systems with the exception of precast manholes, manhole risers, cones, and catch basin barrels shall be Class A-3, as defined in Division 30, Section 30.01, Article 1.6 - Mix Requirements for Classes of Concrete. Concrete Work shall conform to Division 30 – Portland Cement Concrete.

B. Mortar

Cement for mortar used in the construction of storm drain systems shall conform with the requirements of ASTM C-150, Type II. Sand shall conform with the requirements of AASHTO M-45. The mortar shall be composed of one (1) part cement and three (3) parts sand. The addition of lime is not permitted.

Article 1.5 Payment - General

Payment for all Work included in this Division shall be in accordance with Division 10, Section 10.07 - Measurement and Payment and shall include full payment for all Work described.

SECTION 55.02 FURNISH AND INSTALL PIPE

Article 2.1 General

The Work under this Section consists of the performance of all operations pertaining to furnishing and installing pipe for storm drain systems.

In the case of Owner-furnished pipe, the Owner shall allot to the Project pipe to accomplish the Work in amounts exactly matching the Contractor's pay quantities for pipe. Any surplus pipe left over from this allotment at the end of the Project shall be returned from the Contractor's job sites to the Owner's designated pipe yard. If the Contractor withdraws from the Owner's pipe yard more than the amount required to match the payment quantities, the Contractor shall pay the Owner on the basis of the Owner's invoice price for pipe (including freight), plus ten percent (10%) overhead to reimburse the Owner for handling, warehousing, inspection, and administration.

Article 2.2 Material

A. General

All piping shall be in accordance with the Contract Documents conforming to the size and class or model shown and specified.

B. Corrugated Metal Pipe (CMP)

Corrugated metal pipe shall only be used in culvert crossings and similar applications. CMP use in a piped storm drain system is prohibited without approval from Street Maintenance and the Municipal Engineer. Corrugated metal pipe is intended to refer to both steel and aluminum. The pipe shall conform to the following specifications:

1. Steel: Corrugated steel pipe shall meet the requirements of AASHTO M-36.
2. Aluminum: Corrugated aluminum pipe shall conform to the requirements of AASHTO M-196.
3. Aluminum Coated (Aluminized): Corrugated aluminized pipe shall conform to the requirements of AASHTO M-36 and AASHTO M-274.

All CMP fittings shall be fabricated in a workmanlike manner, develop the full strength of the material being joined, and finished to conform to the appropriate requirements of AASHTO M-36, AASHTO M-196 and AASHTO M-274.

Corrugated steel and aluminum pipe shall be jointed by using coupling bands applied as recommended by the manufacturer and approved by the Engineer.

Dissimilar metals may only be used in extending in place metal CMP and reattachment of dissimilar metal end sections provided an electrical insulating material, at least one-sixteenth inch (1/16") in thickness, is used to separate the dissimilar materials.

All angles, bolts, and nuts shall be as recommended by the manufacturer for the type of pipe used and as approved by the Engineer.

The metal gauge for pipe to be used shall be in accordance with the Contract Documents.

If bituminous coating of CMP is required by the Contract Documents, the bituminous coating shall conform to the requirements of AASHTO M-190.

All welding performed by the Contractor on aluminum pipe shall incorporate the use of 4043 or 5356 alloy for welding wire. The welding shall be accomplished by either the "TIG" (tungsten, inert gas shielded) or "MIG" (metal arc welding, inert gas shielded) process.

End Section for Corrugated Metal Pipe - Galvanized steel and aluminum end sections shall be flared, beveled, shop-assembled units to serve as structural, hydraulic and esthetic treatment to corrugated metal pipe culverts. They may be attached to culverts by threaded bolts, by riveting or bolting in accordance with the manufacturer's standard procedure. End sections shall have a turned-down lip or toe plate at the wide end to act as a cutoff. Materials for steel end sections shall be galvanized steel conforming to the requirements of AASHTO M-36. The gauge shall be as follows:

- 16 Ga. Through 24" in diameter or 29" X 18" pipe-arch
- 14 Ga. 30" in diameter and 36" X 22" pipe-arch
36" in diameter and 43" X 27" pipe-arch
- 12 Ga. Over 36" in diameter and 43" X 27" pipe-arch
(except that the center panels of 60" in diameter and larger
and 72" x 44" pipe-arch and larger, shall be 10 Ga.)

Galvanized stiffener angles shall supplement the usual reinforced side edges for sixty inches (60") in diameter and larger, seventy-nine by forty-nine inch (79" x 49") pipe-arch and larger.

If the end section is shop attached to a stub of pipe, the pipe stub shall not be lighter in gauge than the end section.

Materials for aluminum end sections shall comply with the provisions of AASHTO M-196 and fabrication shall comply with the requirements above.

C. Precoated Corrugated Metal Pipe (PCMP)

All precoated corrugated metal pipe and connecting bands shall be coated to meet the AASHTO DESIGNATION: M-245 and M-246 and the coating shall be 10 mils minimum thickness each side. All exposed edges including any perforated hole edges shall be coated with a liquid coating supplied by the supplier of the precoated corrugated pipe. All metal utilized for the precoated metal pipe shall conform to SubArticle 2.2.B - Corrugated Metal Pipe. All metal pipe utilized shall have a nominal wall thickness of 16 gauge for pipes twenty-one inches (21") and larger and 18 gauge for pipes eighteen inches (18") and smaller, unless otherwise noted.

D. Corrugated Polyethylene Pipe (CPEP)

Corrugated polyethylene pipe shall conform to the following specifications:

1. Three inch through ten inch (3" through 10") diameters: AASHTO M-252 or ASTM F2648.
2. Twelve inch (12") and larger diameters: AASHTO M-294 or ASTM F2648.

The corrugated polyethylene pipe covered by these specifications is classified as follows:

Type C - This pipe shall have a full circular cross-section with a corrugated surface both inside and outside. Corrugations may be either annular or helical.

Type S - This pipe shall have a full circular cross-section, with an outer corrugated pipe wall and a smooth inner liner. Corrugations may be either annular or helical.

Type CP - This pipe shall be Type C with Class 2 perforations.

Type SP - This pipe shall be Type S with Class 2 perforations.

All CPEP fittings shall be rotational or blow molded and shall conform to the fitting requirements of AASHTO M-252 or M-294.

Contractor shall join CPEP segments per the manufacturer's recommendations. When a bell and spigot joint is utilized, the Contractor shall ensure that the rubber gasket is correctly inserted into the joint and that the bell is on the upstream end of the pipe.

For connections not using manufactured couplings, the Contractor shall join three inch to ten inch (3" - 10") CPEP with couplings corrugated to match the pipe corrugations or with push-on couplings with locking devices. Contractor shall join twelve inch (12") and larger CPEP with couplings, corrugated to match the index in the pipe corrugations and in a width not less than three-quarters (3/4) of the nominal pipe diameter. All couplings shall be manufactured to lap equally to a distance on each jointed pipe and shall provide a positive means of closure.

All flared end sections and saddles shall be constructed of the same material as the pipe and shall be factory assembled units to serve as structural, hydraulic, and/or aesthetic end treatment to CPEP culverts. CPEP connections shall be as recommended by the manufacturer. The cost of the end section and saddles shall be incidental to the pipe.

CPEP may be connected to CMP or may be used between or connected to dissimilar metals. When CPEP is used as a connection, the Contractor shall construct the connection utilizing a joint specifically manufactured for that type of connection or shall construct the connection in accordance with Standard Detail 55-1.

Contractor shall not insert any portion of the bell of CPEP pipe into any manhole, catch basin, or catch basin manhole unless that portion will be completely removed when the pipe is trimmed to two inches (2") inside the manhole in accordance with Article 5.3, SubArticle B – Storm Drain Manholes and Catch Basin Manholes.

E. High Density Polyethylene Pipe (HDPEP)

High density polyethylene pipe shall conform to the following specifications:

The polyethylene resin shall be classified by ASTM D-1248 as Type III, Class C, Category 5, Grade P34, and have a minimum ASTM D-3350 cell classification of 335434C and a designation of PE 3408 by the Plastic Pipe Institute.

The polyethylene compound shall be suitably protected against ultraviolet light degradation by means of a two percent (2%) concentration of carbon black, well dispersed by pre-compounding in with the resin (by the resin manufacturer).

The pipe shall contain no recycled compound except that generated in the manufacturer's own plant from resin of the same specification from the same raw material supplier. The pipe shall be homogeneous throughout and free of visible cracks, holes, foreign inclusions, or other deleterious defects, and shall be identical in color, density, melt index, and other physical properties.

The pipe shall be designed according to the ISO modified formula in ASTM D-3035. The design pressure rating shall be expressed in terms of the static working pressure in psi for water at 73.4°F according to ASTM D-2837. The minimum allowable pressure rating for gravity pipe shall be 52 psi.

Join pipe lengths to one another using thermal butt fusion. Butt fusion of pipes shall be performed in accordance with the pipe manufacturer's recommendations for equipment and technique, using the correct size equipment and technique. Butt fusion will be performed only by personnel certified as competent by the polyethylene material supplier.

The Contractor shall provide butt fusion equipment compatible with the piping system being used as necessary to complete all joints on the project. All costs in connection with this equipment shall be included in the price bid for pipe installation.

Provide wall pipes or wall fitting as recommended by the pipe manufacturer to connect storm drain and catch basin drain pipes to manholes and catch basins.

Installation of all components shall be accomplished using the manufacturer's recommendations. Unless the Contractor's personnel are certified in the installation of polyethylene pipe, the pipe suppliers shall provide pipe personnel to instruct the Contractor in the handling, installation, and testing of their products. The Contractor shall provide one supplier's representative at the start of construction for on-site services. Additional technical representative services, if necessary, shall also be at the Contractor's expense.

Random tests of field joints will be made by the Engineer, as necessary, as a quality control measure. The Contractor shall be responsible for removal or repair of unsatisfactory butt fusion joints.

F. Polypropylene Pipe (PP)

Polypropylene pipe shall conform to the following specifications:

The pipe shall meet AASHTO M-330. All pipe and fitting joints shall be watertight per ASTM-D3212.

G. Detectable Warning Tape

Detectable underground warning tape is required for installation of all pipe types. Warning tape must not be less than five (5) mil, foil backed, six inches (6") wide vinyl tape, colored green, with "Caution Buried Storm Drain Line Below" continuously printed in black along the tape length.

Article 2.3 Construction

A. Excavation and Backfill

Excavation and backfill for furnishing and installing pipe shall be in accordance with Division 20, Section 20.13 - Trench Excavation and Backfill.

B. Pipe Grade and Alignment

Variance of individual pipe sections from established line and grade shall not be greater than those listed in the table below, providing that such variance does not result in a level or reverse sloping invert.

Allowance Diameter (Inches)	Tolerance (Feet)
8	0.03
10	0.03
12	0.03
14	0.04
16	0.04
18 and greater	0.05

During the progress of the Work, the Contractor shall provide instruments such as transits, levels, laser devices, and other facilities for transferring grades from offset hubs or for setting of batter boards or other construction guides from the control points and bench marks provided by the Contractor. The Contractor shall provide qualified personnel to use such instruments and who shall have the duty and responsibility for placing and maintaining such construction guides. The Contractor shall notify the Engineer forty-eight (48) hours prior to taking measurements on newly installed section of line and/or appurtenances for Record Documents.

If the method of transferring grades from the offset hubs to the pipe require batter-boards, they shall be at least one by six inches (1" x 6") supported on two by four inch (2" x 4") stakes or approved metal rods and shall be placed every twenty-five feet (25'). At least three boards must be in place at any given time to facilitate checking of line and grade. Both line and grade shall be checked for each piece of pipe laid, except at tunnels where methods acceptable to the Engineer shall be used to carry forward line and grade.

The practice of pushing in uncompacted backfill over a section of pipe to provide a platform for transit and level alignment and grade observations shall be subject to the approval of the Engineer. If intermittent backfilling is allowed, backfilling shall be accomplished in accordance with Division 20, Section 20.13 - Trench Excavation and Backfill.

Due to the flexibility of the CPEP, the Contractor shall exert due care while placing bedding and/or filter material and compacting adjacent to and over the pipe. All

placement bedding and/or filter material and compaction shall be per the manufacturer's recommendations.

C. Pipe Laying

CMP and PCMP pipe shall be laid in Class C Bedding and CPEP and HDPEP pipe shall be laid in Class D Bedding unless otherwise required by the Contract Documents or directed by the Engineer.

The Contractor shall exert due care in handling the precoated corrugated metal pipe or while placing bedding and/or filter material around the pipe so as not to damage the coating. The Contractor shall obtain a liquid coating supplied by the precoated corrugated metal supplier which will be painted over scratched or cut sections of the pipe.

Pipe laying shall in all cases proceed upgrade. Each pipe shall be laid true to line and grade and in such a manner as to form a close concentric joint with the adjoining pipe. The alignment of the installed pipe shall appear straight to visual observations and shall be such that a full circle of light can be seen between manholes, etc., when sighting along all points of the pipe circumference. Each section of pipe shall be handled carefully and placed accurately. Each section of pipe shall be properly supported to ensure true alignment and an invert which is smooth and free from roughness or irregularity. On helical pipe, the laps shall not impede the flow and all seams shall be aligned uniformly for the length of the run. At all times, when Work is not in progress, open ends of pipe and fittings shall be securely and satisfactorily closed so that no undesirable substances shall enter the pipe or fittings. All pipe shall be laid in accordance with the respective manufacturer's recommendations. Pipe shall not be laid when the bottom of the ditch or the sides to one foot (1') above the pipe are frozen. Backfill containing frozen material shall not be placed, nor shall the trench be left open during freezing weather so that the temperature of the material near the pipe goes below freezing.

At connections to manholes or catch basins, a minimum eight foot (8') length of pipe shall be provided from the outside edge of the structure to the first pipe joint.

Detectable warning tape shall be continuously laid with the pipe and be at least twenty-four inches (24") and no more than thirty-six inches (36") above the pipe.

D. Low Pressure Air Test

Where watertight pipe is specified on the Drawings, the Contractor must perform a low pressure air test on specified plastic pipes in accordance with ASTM F1417.

E. Televising Storm Drains.

New storm drains twelve inch (12") and greater in diameter shall be inspected by closed circuit television (CCTV) after completion of trench backfill and finished grading but prior to the placement of pavement or permanent trench resurfacing, to determine the existence and extent of any obstructions, structural deficiencies, or sags.

CCTV of storm drains shall be performed in accordance with Section 55.25 – Storm Drain Closed Circuit Television Inspections. CCTV for new pipe and subdrain installations is incidental to the respective bid items.

Article 2.4 Measurement

Measurement for all sizes of pipe shall be based on the horizontal distances and shall be from center to center of manholes, from the center of manholes to center of catch basins, from center of manholes to center of cleanout wye, and from center of manhole to end of pipe including flared end sections. Televising storm drains is considered incidental to the pay item and no separate payment shall be made.

Article 2.5 Basis of Payment

Payment for this Work shall be in accordance with Division 10, Section 10.07 - Measurement and Payment, and shall include full payment for all Work described in this Section.

Payment shall be made under the following units.

ITEM	UNIT
Furnish, Install, and Televising Pipe (Nominal Size, Material)	Linear Foot

SECTION 55.03 SUBDRAINS AND PERFORATED STORM MAINS

Article 3.1 General

The Work under this Section consists of the performance of all operations pertaining to furnishing and installing subdrains and perforated storm drain mainlines.

Article 3.2 Material

- A. All piping shall be in accordance with the Contract Documents and shall be the sizes shown and specified.
- B. The Contractor shall use perforated steel, perforated aluminum or perforated aluminized coated corrugated metal pipe as noted. Corrugated metal pipe shall conform to the provisions of Section 55.02 - Furnish and Install Pipe. Perforations shall be located and sized in accordance with the requirements of AASHTO M-36.
- C. Corrugated Polyethylene Pipe (CPEP) shall conform to the provisions of Section 55.02 - Furnish and Install Pipe. Size and locate perforations in accordance with the requirements of AASHTO M-252 for pipe diameters three to ten inches (3" to 10") and AASHTO M-294 for pipe diameters twelve to sixty inches (12" to 60"). Perforations shall be Class 2. Perforations shall be cleanly cut so that water inflow is not restricted and shall be uniformly spaced along the length of the pipe.

Unless shown otherwise on drawings, Type D Filter Material shall be used on all CPEP pipe diameters three to ten inches (3" to 10") and Type C Filter Material shall be used on all CPEP pipe diameters from twelve to sixty inches (12" to 60").

- D. Geotextile fabric shall conform to Division 20, Section 20.25 – Geotextile Fabric, and shall be non-woven, pervious drainage material.

Article 3.3 Construction

Unless shown otherwise on drawings, refer to Standard Detail 55-3 for construction of subdrains and perforated storm drain mainlines. Each phase of construction shall be accomplished in accordance with the applicable sections of these Specifications. Excavation and backfill for furnishing and installing of subdrains and perforated storm drain mainlines shall be in accordance with Division 20, Section 20.13 - Trench Excavation and Backfill. Furnish and install subdrains and perforated storm drain mainlines in accordance with Section 55.02 - Furnish and Install Pipe. Furnish filter material in accordance with Division 20, Section 20.17 - Furnish Filter Material.

Article 3.4 Measurement

Measurement for all sizes of pipe shall be based on the horizontal distances and shall be from center to center of manholes, from the center of manholes to center of catch basins, from center of manholes to center of cleanout wye, and from center of manhole to end of pipe including flared end sections. Measurement includes furnishing, installing, and televising pipe; furnishing and placing filter material; and, when required by the Contract Documents, furnishing and installing geotextile fabric.

Article 3.5 Basis of Payment

Payment for this Work shall be in accordance with Division 10, Section 10.07 - Measurement and Payment, and shall include full payment for all Work described in this Section.

Payment shall be made under the following units:

ITEM	UNIT
Furnish, Install & Televiser Subdrain (Nominal Size, Material, and Type of Filter Material)	Linear Foot
Furnish, Install & Televiser Subdrain with Geotextile (Nominal Size, Material, Type of Filter Material, and Type of Geotextile Fabric)	Linear Foot
Furnish, Install & Televiser Perforated Storm Mains (Nominal Size, Material, and Type of Filter Material)	Linear Foot
Furnish, Install & Televiser Perforated Storm Mains with Geotextile (Nominal Size, Material, Type of Filter Material, and Type of Geotextile Fabric)	Linear Foot

SECTION 55.04 MODIFICATIONS TO EXISTING MANHOLES OR CATCH BASINS

Article 4.1 General

The Work under this Section consists of rehabilitating and providing new connections to existing manholes or catch basins. The Contractor shall provide all labor and materials required to furnish and install new manhole and catch basin components needed.

Modifications to existing manholes or catch basins can include, but are not limited to, furnishing and installing new pipe penetrations, as well as removal and replacement of manhole covers and frames, grade rings, cone section, barrel ring/riser section, base section, and ladder rungs.

Article 4.2 Materials

The materials for replacement components to be used in the Work are to comply with the requirements of this Division, the Standard Details, and the Drawings. The Contractor shall furnish new, unused materials for those components identified to be replaced.

Article 4.3 Construction

The Contractor shall reuse components that are not identified to be replaced. Damage by the Contractor that renders any such component unusable is to be replaced by the Contractor with new material at no additional cost to the Owner. If the Contractor finds that a component that is not identified to be replaced cannot be moved, adjusted, repaired, or worked on without damaging the component, the Engineer shall be notified in order to assess the component's ability to be re-used.

Excavation, shoring, dewatering, backfill, and compaction efforts required for modifications to existing manholes or catch basins shall be in accordance with Division 20 - Earthwork.

The Contractor shall remove and replace manhole and catch basin components as identified in the Drawings. Upon removal of manhole components, the Contractor shall clean and prepare remaining and connecting component parts prior to installation of replacement parts; this includes removal of existing grout and sealants. Installation of new sections is to be constructed to produce a smooth, regular, watertight surface.

Salvaged components shall be removed in a workman-like manner and delivered to a site as directed by the Engineer. Non-salvageable materials shall be removed to a Contractor-provided disposal site.

Connections to existing manholes or catch basins shall be made in a workmanlike manner. The invert shall be brought into the existing manhole at the elevation shown on the Drawings. The downstream pipe in manholes shall be screened to prevent entry of mortar or other debris from entering the system.

After connection is made to a storm drain manhole and the mortar holding the pipe in place has set, cut the pipe off evenly so that no more than two inches (2") of pipe protrudes into the manhole and remove any screening.

Upon completion of manhole or catch basin modifications, the Contractor shall restore the existing grade and surrounding area to preconstruction conditions.

Article 4.4 Measurement

Modifications to existing manholes and connections to manholes shall be measured as complete units in place. Unless specifically identified for payment under a separate bid item, all excavation, shoring, dewatering, backfill, compaction, restoration of existing preconstruction conditions, and disposal of unusable material necessary to complete the Work is incidental.

Article 4.5 Basis of Payment

Payment for this Work shall be in accordance with Division 10, Section 10.07 - Measurement and Payment, and shall include full payment for all Work described in this Section.

Payment shall be made on the following basis:

ITEM	UNIT
Remove and Replace Manhole Cover and Frame	Each
Remove and Replace Grade Ring	Each
Remove and Replace Manhole Cone Section	Each
Remove and Replace Manhole Barrel Ring/Riser Section	Each
Remove and Replace Manhole Base Section	Each
Remove and Replace Ladder Rung	Each
Connect to Existing Storm Drain Manhole	Each
Connect to Existing Storm Drain Catch Basin	Each

SECTION 55.05 MANHOLES AND CATCH BASIN MANHOLES

Article 5.1 General

The Work under this Section consists of the performance of all Work required for the construction of storm drain manholes and catch basin manholes complete with frames and covers.

Article 5.2 Material

A. Frames and Covers

Manhole and catch basin manhole frames and covers shall conform to the Standard Details, meet the requirements of ASTM A-48/AASHTO M-306, and be rated Heavy Duty (H-20 loading minimum). Gray cast iron shall have a minimum tensile strength of 35,000 pounds per square inch (PSI). Inlet grates shall conform to the Standard Details and the requirements of ASTM A536. Manhole frames, covers, and grates shall be furnished with machined horizontal bearing surfaces. The cover or grate shall not rock when rotated to any position in the frame.

Gray iron castings shall have appropriate certifications and be individually marked in accordance with the requirements of AASHTO M-306.

B. Reinforced Concrete Manholes

Material used in the construction of reinforced concrete manholes shall conform to the requirements of ASTM C-478 and the Standard Details. Cones shall be eccentric unless otherwise approved. Forty-eight inch (48") reinforced concrete pipe may be used for manhole riser sections as an alternate. This pipe shall conform to the requirements of ASTM C-76 with a minimum thickness of five inches (5").

Each precast concrete barrel section and eccentric cone shall be set and sealed by use of a pre-molded plastic gasket pipe joint sealer as manufactured by Henry Co, Ram-Nek Sealant Division or equal and installed to the manufacturer's specification and meets ASTM C990. Each concrete adjusting ring and manhole cover/frame that falls outside of a paved road section shall be set and sealed by a pre-molded plastic gasket sealer. Each concrete adjusting ring and manhole cover/frame that falls in a paved road section/sidewalk shall be set in a full bed of mortar. Mortar shall conform to Division 55, Section 55.01, Article 1.4B. The joints shall be constructed so as to produce a smooth, regular, watertight surface. Water shall be added in minimum amounts to provide plasticity in placing the mortar.

Refer to Division 30, Section 30.01, Article 1.6 - Mix Requirements for Classes of Concrete, for Specifications pertaining to Class A-3 concrete as required in forming manhole inverts.

Reinforcement steel shall conform to the requirements of ASTM A-185, ASTM A-615, Grade 60 steel, or better, and the Standard Details.

Article 5.3 Construction

A. General

Excavation and backfill for the construction of storm drain manholes and catch basin manholes shall be in accordance with Division 20, Section 20.13 - Trench Excavation and Backfill.

All portions of the manholes must be approved by the Engineer prior to installation in the storm drain system. The Contractor shall provide timely notice (at least two Working days in advance of casting) to allow time for the Engineer to arrange for necessary inspections. Installation of manhole sections without the Engineer's written approval shall not be allowed. This approval does not relieve the Contractor of the responsibility for protection of manholes against damage during handling and installation.

The manhole frames and covers shall be brought to grade in accordance with Standard Details unless otherwise shown on the Drawings or approved by the Engineer. Manhole rings shall be set in a full bed of mortar and made secure. Grade adjustment rings must be set centered over the manhole and catch basin cone or lid opening with no lateral offset. No more than a one-quarter inch (1/4") lateral offset is permitted between grade adjustment rings. Total cumulative offset between grade adjustment rings shall not exceed one-half inch (1/2"). Manhole rings and catch basin frames shall be set centered on the opening with a maximum lateral offset of one-half inch (1/2") permitted.

Manholes shall be installed at the location shown on the Drawings and primary leads shall enter radially at the invert elevations specified. The base section shall be set plumb on a prepared surface. Prepared surface shall be compacted to a minimum of ninety-five percent (95%) of maximum density.

In the case of precast manhole barrel sections where holes need to be bored to provide for the storm drain pipe, the diameter of the bore shall not exceed the outside diameter of the storm drain pipe plus one and one-half inches (1.5").

Where indicated on the Drawings, a stub shall be provided for future connections to the manhole. The stub shall be sized and positioned as indicated. The end of the stub shall be stopped with a wooden plug, concrete biscuit, or other adequate methods to prevent water, earth, or other substances from entering the pipe. Manholes up to twelve feet (12') in depth shall have ten foot (10') stubouts; over twelve feet (12') in depth shall have twenty foot (20') stubouts.

In the case of poured-in-place manhole construction, if the Contractor elects to accomplish the manhole construction utilizing more than one continuous concrete pour, a keyed construction joint shall be used. These manholes shall have poured-in-place bases. Precast concrete barrel sections shall be set and sealed with premolded plastic gasket. Premolded plastic gaskets for sealing pre-cast concrete barrel sections for manholes shall meet ASTM C-990 and shall be installed in accordance with the manufacturer's recommendations. Gaskets shall be trimmed on the inside of the manhole to prevent the excess gasket material from entering the storm drain lines.

B. Storm Drain Manholes and Catch Basin Manholes

Contractor shall construct storm drain manholes in accordance with the Drawings and Standard Details. In the invert of manholes, Contractor shall construct a catch of eighteen inches (18”) minimum depth, unless otherwise specified.

After connecting the storm drain pipe to reinforced concrete manhole or catch basin, seal annular space around pipe penetrations with cement mortar, or an approved equal. Mortar used in the sealing of joints and connections shall conform to Division 55, Section 55.01, Article 1.4B. After the mortar has firmly set, Contractor shall cut the pipe evenly so that no more than two inches (2”) of the pipe protrudes into the manhole.

Article 5.4 Measurement

Manholes and catch basin manholes shall be measured as units complete in place. Depth of manholes and catch basin manholes shall be based upon a measurement to the nearest foot from top of casting to the top of the base slab. Standard depths for manholes and catch basin manholes shall be constructed in accordance with the Standard Details and designated as to type.

TYPE	STANDARD DEPTH
Type I, II, III	twelve feet (12')

All depths over the specified standard depth shall be paid for under the bid item "Additional Depth to Manhole" as defined below:

Additional Depth for Manholes:

This item consists of the construction of additional depth to manholes over and above the twelve foot (12') depth specified below. Additional depth to manholes and catch basin manholes shall be complete in place.

Article 5.5 Basis of Payment

Payment for this Work shall be in accordance with Division 10, Section 10.07 - Measurement and Payment, and shall include full payment for all Work described in this Section.

Payment shall be made on the following basis:

ITEM	UNIT
Construct (Type, Diameter*) Manhole	Each
Construct (Type) Catch Basin Manhole	Each
Additional Depth to (Type) Manhole	Linear Foot

* For Type III manholes, include the diameter in the descriptor for the appropriate pay item.

SECTION 55.06 WATERTIGHT MANHOLE FRAMES AND COVER

Article 6.1 General

The Work under this Section consists of the performance of all Work required for the construction of watertight manhole frames and covers.

Article 6.2 Material

Watertight frames and covers for manholes and similar appurtenances shall conform to the Standard Details, meet the requirements of ASTM A-48/AASHTO M-306, and be rated Heavy Duty (H-20 loading minimum). Gray cast iron shall have a minimum tensile strength of 35,000 PSI. Contact surfaces between frames and covers shall be machined to provide a uniform contact surface. Manhole covers shall have identification letters as shown on the Standard Details.

Article 6.3 Construction

Provide watertight manhole frames and covers as indicated on the Drawings and in accordance with the Standard Details.

Article 6.4 Measurement

Watertight manhole frames and covers shall be measured as complete units in place.

Article 6.5 Basis of Payment

Payment for this Work shall be in accordance with Division 10, Section 10.07 - Measurement and Payment, and shall include full payment for all Work described in this Section.

Payment is to be made only for the additional cost of furnishing and installing the watertight frame and cover which exceeds the cost of the standard frame and cover included in the completed manhole unit price.

Payment shall be made under the following unit:

ITEM	UNIT
Additional Cost of Watertight Manhole Frame and Cover	Each

SECTION 55.07 ADJUST MANHOLE CONE, MANHOLE RING, OR CATCH BASIN TO FINISH GRADE

Article 7.1 General

The Work under this Section consists of providing all operations pertaining to the adjustment of existing manholes or catch basins to finish grade. All broken and/or missing manhole or catch basin components are to be replaced with new materials furnished and installed by the Contractor in accordance with these Specifications.

Article 7.2 Material

All materials used in the adjustment of manhole cones and rings including mortar, steps, barrel sections, premolded plastic gaskets, etc., shall conform to the requirements for manholes as outlined in Section 55.05 - Manholes and Catch Basin Manholes.

All materials used in the adjustment of catch basins shall conform to the requirements for catch basins as outlined in Section 55.09 - Construct Catch Basin.

Radial concrete manhole blocks may be used for upward adjustments in certain cases if approved by the Engineer.

The Contractor may utilize Neenah R-1979 Series Manhole Adjusting Rings, or an approved equal, for adjusting the manhole to finished grade.

Article 7.3 Construction

The Contractor shall make adjustments to existing manholes and catch basins in accordance with the applicable Standard Details. Each precast concrete barrel, cone section, or adjusting ring shall be set upon and sealed with a premolded plastic gasket which shall meet ASTM C990. The casting can be set in a bed of mortar with steel adjusting shims in the event the grade will not allow the premolded plastic gasket material. The steel shims shall be placed in four locations as a minimum and must be approved by the Engineer.

Grade adjustment rings must be set centered over the manhole and catch basin lid opening or cone with no lateral offset. No more than a one-quarter inch (1/4") lateral offset is permitted between grade adjustment rings. Total cumulative offset between grade adjustment rings shall not exceed one-half inch (1/2"). Manhole rings and catch basin frames shall be set centered on the opening with a maximum lateral offset of one-half inch (1/2") permitted.

Rotational as well as vertical displacement of the catch basin top and casting might occur. All adjustments will be accomplished as directed by the Engineer.

A horizontal milling process whereby the casting is milled to lower the top to meet the finish grade of the street is an approved method of lowering the manhole grade. This method must be submitted to the Engineer for approval.

Contractor shall remove and replace pavement around the manhole in such a way to minimize impact to the travel path of the roadway. Contractor shall either use infrared treatment to fuse old and new pavement or shall make the pavement cut in such a way to prevent a straight-line patch from occurring perpendicular to the direction of travel. Pavement cuts shall be made in a diamond shape in relation to the travel path rather

than a square shape. Contractor shall adjust the manhole or catch basin to finish grade prior to placement of asphalt pavement. Contractor shall have an inventory of extra grade rings, comprised of a few of each adjustment height (2" through 6"), available on site during paving. New asphalt shall not be cut for adjustments.

Any damage to manholes or catch basins resulting from construction under this Contract shall be repaired or the damaged portion replaced at the Contractor's expense. All inverts, benchwalls, and catch areas shall be left clean and free from any foreign materials.

Article 7.4 Measurement

Manhole cone, manhole ring, and catch basin adjustments shall be measured as units, complete in place.

Article 7.5 Basis of Payment

Payment for this Work shall be in accordance with Division 10, Section 10.07 - Measurement and Payment, and shall include full payment for all Work described in this Section.

Payment for manhole cone or ring adjustments shall include full compensation for changes in height per the applicable Standard Details, unless otherwise directed by the Engineer. In no case will payment for both ring and cone adjustments be made for the same manhole. Any adjustments requiring cutting of new asphalt shall not be paid and shall be deducted from the plan quantity.

Payment shall be made under the following unit:

ITEM	UNIT
Adjust Storm Drain Manhole Cone	Each
Adjust Storm Drain Manhole Ring	Each
Adjust Catch Basin to Finish Grade	Each

SECTION 55.08 THIS SECTION INTENTIONALLY LEFT BLANK

SECTION 55.09 CONSTRUCT CATCH BASIN

Article 9.1 General

The Work under this Section consists of the performance of all operations pertaining to the construction and installation of catch basins.

Article 9.2 Material

Materials used in the construction of catch basins shall conform to the requirements of ASTM C-478 and the Standard Details.

For concrete used in the formation of catch basin base slabs, refer to Division 55, Section 55.01, Article 1.4A.

Mortar used in the construction of catch basins, including sealing of joints and connections, shall conform to Division 55, Section 55.01, Article 1.4B.

Article 9.3 Construction

Excavation and backfill for furnishing and installing of catch basin shall be in accordance with Division 20, Section 20.13 - Trench Excavation and Backfill.

Reducing slab shall be set and sealed by a pre-molded plastic gasket joint sealer as manufactured by Henry Co., Ram-Nek Sealant Division or equal and installed to the manufacturer's specification. Plastic gasket joint sealers shall meet ASTM C-990.

Contractor shall bring catch basin rings and covers to the grades shown on the Drawings. Grade stakes defining the elevation of the casting, and hub stakes with tacks to define the line for the curb face shall be set by the Contractor. The Contractor may accomplish final setting of the casting by wedging it up with masonry material as approved by the Engineer. The casting shall then be set in a full bed of mortar and made secure.

All joints and connections are to be mortared. The joints shall be made so as to produce a smooth, regular, watertight surface. Water shall be added in minimum amounts to provide plasticity in placing the mortar.

After connecting the storm drain pipe to catch basin, seal annular space around pipe penetration with cement mortar, or an approved equal. After the mortar has set firmly, the pipe is to be cut off evenly so that no more than two inches (2") of the pipe protrudes into the catch basin.

Article 9.4 Measurement

Catch Basins shall be measured as units complete in place.

Article 9.5 Basis of Payment

Payment for this Work shall be in accordance with Division 10, Section 10.07 - Measurement and Payment, and shall include full payment for all Work described in this Section.

Payment shall be made on the following basis:

ITEM	UNIT
Construct Catch Basin	Each

SECTION 55.10 RELOCATE CATCH BASIN OR CATCH BASIN MANHOLE

Article 10.1 General

The Work under this Section consists of providing all operations pertaining to relocating of existing catch basin or catch basin manholes.

Article 10.2 Material

All materials used in relocation of catch basins or catch basin manholes shall conform to the requirements for catch basins as outlined in Section 55.05 - Manholes and Catch Basin Manholes and Section 55.09 - Construct Catch Basin.

Article 10.3 Construction

The Contractor shall note the fact that the relocation of more than one type of catch basin or catch basin manhole may be required under this Contract. All excavation, trenching and backfill necessary for the removal and relocation shall be considered incidental to this item. The Contractor shall backfill the excavation with suitable, non-frost-susceptible material and compact it to not less than ninety-five percent (95%) of maximum density as directed by the Engineer. If additional material is required for backfill it will be paid for under the item "Furnish Trench Backfill." Existing leads may require relocation up to a maximum length of fifteen feet (15') to provide proper alignment. Such relocation shall be considered incidental to this Item. Pipe used shall be the same size and type as the existing leads. The relocated catch basin or catch basin manholes shall be adjusted to finish grade as directed by the Engineer.

Article 10.4 Measurement

Relocation of catch basins or catch basin manholes will be measured on a basis of units complete in place at the new location and accepted by the Engineer.

Article 10.5 Basis of Payment

Payment for this Work shall be in accordance with Division 10, Section 10.07 - Measurement and Payment, and shall include full payment for all Work described in this Section.

Payment shall be made under the following units:

ITEM	UNIT
Relocate Catch Basin	Each
Relocate Catch Basin Manhole	Each

SECTION 55.11 REMOVE MANHOLE OR CATCH BASIN

Article 11.1 General

The Work under this Section consists of providing all operations pertaining to the removal and disposal or salvage of existing manholes or catch basins.

Article 11.2 Construction

Salvaged materials shall be removed in a workman-like manner and delivered to a site as directed by the Engineer. Non-salvageable materials shall be removed to a Contractor-provided disposal site.

Any excavation required in the removal shall be considered incidental to this item. The Contractor shall backfill the excavation with a suitable, non-frost susceptible material and compact it to not less than ninety-five percent (95%) of maximum density as directed by the Engineer. If additional material is required for backfill, it will be paid for under the Item "Furnish Trench Backfill." Existing pipes shall be suitably plugged and abandoned unless otherwise noted.

Article 11.3 Measurement

Removal of existing manholes or catch basins will be measured as units.

Article 11.4 Basis of Payment

Payment for this Work shall be in accordance with Division 10, Section 10.07 - Measurement and Payment, and shall include full payment for all Work described in this Section.

Payment shall be made under the following units:

ITEM	UNIT
Remove Manhole	Each
Remove Catch Basin	Each

SECTION 55.12 THIS SECTION INTENTIONALLY LEFT BLANK

SECTION 55.13 ABANDON CATCH BASIN LEAD

Article 13.1 General

The Work under this Section consists of performing all operations pertaining to the abandonment of catch basin leads. Catch basin leads to be abandoned may be crushed in place, filled with sand slurry, or removed, at Contractor's option and approval by the Engineer.

Article 13.2 Materials

Sand slurry shall consist of a mixture of water and sand with an approximate ratio of seven gallons of water per cubic foot of sand. Native materials that contain no lumps, frozen material, organic matter, or other deleterious material are acceptable for use in the slurry mixture.

Article 13.3 Construction

Contractor shall abandon catch basin leads as shown on the Drawings. The opening in the storm drain manhole where the catch basin lead enters shall be plugged with concrete grout and abandoned per Contractor's option and approval by the Engineer.

Where catch basin leads lie within trench excavation, as called for in the Drawings and Specifications, the leads shall be removed.

Article 13.4 Measurement

Abandonment of each catch basin lead shall be measured as a complete unit. This item will include materials, excavations, placement of materials, disposal of unusable materials, backfill, and incidental operations.

Article 13.5 Basis of Payment

Payment for this Work shall be in accordance with Division 10, Section 10.07 - Measurement and Payment, and shall include full payment for all Work described in this Section.

Payment shall be made under the following unit:

ITEM	UNIT
Abandon Catch Basin Lead	Each

SECTION 55.14 CONSTRUCT STORM DRAIN CLEANOUT

Article 14.1 General

The Work under this Section consists of the performance of all Work required for the construction and installation of storm drain cleanouts.

Article 14.2 Material

Materials used in the construction of storm drain cleanouts shall conform to the Standard Details.

Article 14.3 Measurement

Storm drain cleanouts shall be measured as units, complete in place.

Article 14.4 Basis of Payment

Payment for this Work shall be in accordance with Division 10, Section 10.07 - Measurement and Payment, and shall include full payment for all Work described in this Section.

Payment shall be made on the following basis:

ITEM	UNIT
Construct Storm Drain Cleanout	Each

SECTION 55.15 ADJUST STORM DRAIN CLEANOUT TO FINISH GRADE

Article 15.1 General

The Work under this Section consists of providing all operations pertaining to adjustment of existing cleanouts to finish grade. All broken and/or missing cleanout components are to be replaced with new materials furnished and installed by the Contractor in accordance with these Specifications.

Article 15.2 Material

All materials used in the adjustment of cleanouts shall conform to the requirements for cleanouts as outlined in Section 55.14 - Construct Storm Drain Cleanout.

Article 15.3 Construction

The Contractor may be required to adjust more than one type of cleanout under this Contract. All adjustments will be accomplished as directed by the Engineer. Any damage to cleanouts resulting from construction under this Contract shall be repaired or the damaged portion replaced at the Contractor's expense.

Article 15.4 Measurement

Cleanout adjustments will be measured per unit, complete in place.

Article 15.5 Basis of Payment

Payment for this Work shall be in accordance with Division 10, Section 10.07 - Measurement and Payment, and shall include full payment for all Work described in this Section.

Payment shall be made under the following unit:

ITEM	UNIT
Adjust Storm Drain Cleanout to Finish Grade	Each

SECTION 55.16 CONSTRUCT DROP CONNECTION

Article 16.1 General

The Work under this Section consists of the performance of all Work required for the construction and installation of storm drain drop connections to manholes.

Article 16.2 Material

Pipe and fittings used in the construction of drop connections for storm drain shall conform to the requirements of Section 55.02 - Furnish and Install Pipe and the Standard Details.

For materials used in the construction of the concrete cradle, refer to Division 55, Section 55.01, Article 1.4A.

Article 16.3 Construction

Excavation and backfill for the construction of drop connection to manhole shall be in accordance with Division 20, Section 20.13 - Trench Excavation and Backfill.

Over-excavation under drop connection shall require compaction of not less than ninety-five percent (95%) of the maximum density prior to installation of the pipe and fittings, or the concrete cradle.

Article 16.4 Measurement

Storm drain drop connections shall be measured as units, complete in place.

Article 16.5 Basis of Payment

Payment for this Work shall be in accordance with Division 10, Section 10.07 - Measurement and Payment, and shall include full payment for all Work described in this Section.

Payment shall be made on the following basis:

ITEM	UNIT
Construct Storm Drain Drop Connection	Each

SECTION 55.17 FLUME DOWNDRAIN

Article 17.1 General

The Work under this Section consists of performing all operations pertaining to furnishing and installing flume downdrain(s) with anchor assemblies at locations shown on the Drawings.

Article 17.2 Materials

All material utilized in the fabrication of the galvanized metal flume downdrain(s) shall conform to Section 55.02 - Furnish and Install Pipe with a minimum sheet thickness of six-hundredths inches (0.060").

Article 17.3 Construction

The flume downdrain(s) shall be fabricated in accordance with the details and dimensions shown on the Drawings. No dissimilar metal shall be allowed at any installation. Anchor assemblies shown on the Drawings may be used with an aluminum installation provided the anchor assemblies are electrically insulated. All flume sections shall be connected together and to the existing pipe by means of galvanized bolts as indicated on the Drawings.

Article 17.4 Measurement

Measurement shall be based on the horizontal length of flume downdrain measured from the top end of the flume downdrain to end of flared or half-round metal pipe modified end section complete in place with anchors properly placed in the ground and bolted to the flume downdrain pipe.

Article 17.5 Basis of Payment

Payment for this Work shall be in accordance with Division 10, Section 10.07 - Measurement and Payment, and shall include full payment for all Work described in this Section.

Payment shall be made under the following unit:

ITEM	UNIT
Furnish and Install Flume Downdrain (Size)	Linear Foot

SECTION 55.18 FOOTING DRAIN SERVICES

Article 18.1 General

The Work under this section includes all material, labor, and equipment necessary for construction, connection, and/or disconnection/reconnection of footing drain services to the storm drain system.

Article 18.2 Material

For new footing drain service construction, Contractor shall provide CPEP (Type S) pipe bedded in Filter Material (Type B), or as specified on the Drawings. Connect footing drain services to the storm drain with a saddle of a type recommended by the pipe manufacturer.

For reconnection of footing drain services, Contractor shall reconnect the existing footing drain service to the storm drain with a saddle of appropriate size and of a type recommended by the pipe manufacturer.

Article 18.3 Construction

Excavation and backfill for the construction of footing drain services shall be in accordance with Division 20, Section 20.14 - Trench Excavation, Backfill and Compaction for Service Connections and is incidental to the service connection bid item. The number and approximate location of footing drain services are shown on the Drawings.

Contractor shall follow the footing drain saddle manufacturer's recommendations for installation, including ensuring that the connection is the correct size and shape and that the cut edges are smooth.

Article 18.4 Measurement

Footing drain services is measured as units, complete in place.

The Work under this Section includes all materials, equipment, and Work required to construct, connect, disconnect, and/or reconnect the footing drain services as indicated on the Drawings and in accordance with this Division and Division 20 – Earthwork. Such materials, equipment, and Work are incidental and no additional payment is made for the following:

Trench Excavation and Backfill, Unusable or Surplus Excavation, Disposal of Unusable or Surplus Material, Usable Excavation, Type B Filter Material, Furnish and Install Pipe, Mechanical Compaction, Type II Trench Backfill, Shoring, Sheeting, Bracing, and Canousa Wrap.

Article 18.5 Basis of Payment

Payment for this Work shall be in accordance with Division 10, Section 10.07 - Measurement and Payment, and shall include full payment for all Work described in this Section.

ITEM	UNIT
Disconnect/Reconnect Footing Drain Service	Each
Construct Footing Drain Service (Size)	Each

SECTION 55.19 CONSTRUCT OPEN DITCH

Article 19.1 General

The Work under this Section consists of the performance of all Work required for the excavation, embankment and spreading of material necessary to construct an open ditch.

Article 19.2 Construction

A. Excavation

Excavation shall be to the grade and ditch cross section shown on the Drawings. The final ditch shall have no projections of roots, stumps, rock, or similar matter. Material hauled from the job site for disposal shall be paid for under Division 20, Section 20.10, Article 10.7 – Disposal of Unusable Material.

B. Embankment

Embankment shall be to the shape and at the location shown on the Drawing. The type of material utilized to construct ditch banks and dikes shall be as noted on the Drawing, or as approved by the Engineer. If additional material is required for embankment, it will be paid for under Division 20 - Earthwork.

C. Cleanup

The Contractor shall maintain the ditch and keep it open and free from all debris, as directed by the Engineer until final acceptance.

Article 19.3 Measurement

Measurement for open ditch construction shall be per linear foot along the slope of the ditch.

Article 19.4 Basis of Payment

Payment for this Work shall be in accordance with Division 10, Section 10.07 - Measurement and Payment, and shall include full payment for all Work described in this Section.

Payment shall be made on the following basis:

ITEM	UNIT
Construct Open Ditch	Linear Foot

SECTION 55.20 CULVERT

Article 20.1 General

The Work under this Section consists of the performance of all materials and operations required to furnish and install culverts.

Article 20.2 Material

All material utilized in the fabrication of culverts shall conform to Section 55.02 - Furnish and Install Pipe.

Article 20.3 Construction

Excavation and backfill for furnishing and installing of culverts shall be in accordance with Division 20, Section 20.13 - Trench Excavation and Backfill.

The Contractor shall furnish and install culverts as shown on the Drawings. The pipe shall be installed to the alignment and grades as required by the Drawings. The pipe shall be installed so that there is a minimum of twelve inches (12") of cover over the pipe before the placement of surfacing materials. Excavation, backfilling, compaction, and grading or ditching necessary to direct water into or out of the culvert, are incidental items and no separate payment shall be made.

Where additional backfill material is required, it shall be classified fill or backfill in accordance with Division 20, Section 20.21 – Classified Fill and Backfill and as directed by the Engineer. Disposal of unusable material shall be paid under "Disposal of Unusable Material" as designated in the Bid Proposal.

Article 20.4 Measurement

Measurement of culverts shall be per linear foot along the slope of the pipe from end to end.

Article 20.5 Basis of Payment

Payment for this Work shall be in accordance with Division 10, Section 10.07 - Measurement and Payment, and shall include full payment for all Work described in this Section.

Payment shall be made on the following basis:

ITEM	UNIT
Culvert (Pipe Size, Material, Gauge, Shape)	Linear Foot

SECTION 55.21 FIN DRAIN

Article 21.1 General

The Work under this Section consists of performing all operations pertaining to furnishing and installing an impervious subsurface fin drain system as shown on the Drawings or as directed by the Engineer.

Article 21.2 Materials

The fin drain system shall consist of a flexible, impervious, vertical core made of a deeply dimpled, high-strength styrene sheet and a perforated storm pipe enveloped in a non-woven polypropylene filter fabric.

The subsurface fin drain system shall be Miradrain 6200 XL, or an approved equal.

A. Fin Core

The fin core shall consist of a deeply dimpled, high-strength, non-biodegradable styrene sheet. Provide fin core which is dimpled on both sides of the shaft. Dimple pattern shall create open channels between the dimples 0.40 to 0.80 cm wide and not less than 0.80 cm deep, which allows water flow along the face of the fin core on both sides in all directions.

B. Filter Fabric

The filter fabric shall conform to the requirements of Division 20, Section 20.25 - Geotextile Fabric for subsurface drainage and riprap lining (Type C Geotextile) or an approved equal.

C. Pipe

The perforated encased pipe shall conform to the requirements of Section 55.02 - Furnish and Install Pipe. Compaction adjacent to the pipe shall conform to Division 20, Section 20.13 - Trench Excavation and Backfill and the manufacturer's recommendations. The perforations in the pipe shall conform to Section 55.03 - Subdrains and Perforated Storm Mains.

Article 21.3 Construction

Contractor shall install the fin drain in accordance with the manufacturer's recommendations and the applicable provisions of Division 20, Section 20.17 - Furnish Filter Material; Section 20.01, Article 1.5 - Compaction Standards; Section 20.25 - Geotextile Fabric; Section 55.02 - Furnish and Install Pipe; Section 55.03 - Subdrains and Perforated Storm Mains; and this Section. The Work under this Section shall include mechanical compaction, non-woven geotextile fabric, pipe, fin core, installing the fin drain system, filter material (Type C), Trench Excavation and Backfill, and Disposal of Unusable Material.

Article 21.4 Measurement

The method of measurement for furnishing and installing the fin drain shall be per linear foot based on the horizontal distance measured from center of manhole to center of manhole and center of manhole to center of cleanout riser.

Article 21.5 Basis of Payment

Payment for this Work shall be in accordance with Division 10, Section 10.07 - Measurement and Payment, and shall include full payment for all Work described in this Section.

Payment shall be made under the following unit:

ITEM	UNIT
Furnish and Install Fin Drain (Size, Type)	Linear Foot

SECTION 55.22 OIL AND GRIT SEPARATOR

Article 22.1 General

The Work under this section consists of performing all operations pertaining to constructing a storm drain oil and grit separator, complete with manhole structure, frames, covers, and diversion apparatus as shown on the Drawings, or as the Engineer directs.

Article 22.2 Materials

Contractor shall furnish and install a Stormceptor oil and grit separator manufactured by:

Rinker Materials/Stormceptor 800 NE Tenney Road, Suite 413 Vancouver, WA 98685 Phone: 503-572-9894 FAX: 503-296-2023	Local Contacts: D & S Concrete, Inc. 2140 E 84th Ct Anchorage, AK 99507 Phone: 907-349-6031 FAX 907-349-4597 or an approved equal.	Local Contacts: CONTECH Vortechinics OGS Systems 111 E. 100th Avenue Anchorage, Alaska 99515 Phone: 907-344-1144 Fax: 907-344-1174. or an approved equal.
--	--	--

Contractor shall backfill the excavation with Type II Classified Fill and Backfill material. If foundation material is required, provide "Foundation Backfill (Type II)."

The storm drain manhole shall conform to the requirements of Section 55.05 - Manholes and Catch Basin Manholes and the Drawings. The diversion apparatus shall conform to the requirements of the oil and grit separator manufacturer's specifications and Standard Detail 55-29B.

Contractor shall provide access to the structure through two (2) manhole frames and covers. The smaller cover shall conform to Standard Detail 55-4. The manufacturer of the oil and grit separator shall provide the larger cover clearly marked "oil/grit separator" and the larger cover shall support HS-20 loadings.

Article 22.3 Construction

Contractor shall install the separator in accordance with Section 55.05 - Manholes and Catch Basin Manholes and the separator unit manufacturer's specifications.

Contractor shall backfill around the manhole with a minimum of three feet (3') Type II Classified Fill and Backfill to the full depth of the manhole, compacted in accordance with Division 20, Section 20.21 - Classified Fill and Backfill. Classified Fill and Backfill is incidental to this pay item, and no separate payment shall be made.

Article 22.4 Measurement

Oil and grit separator is measured as a complete unit in place and shall include the concrete manhole, diversion apparatus, frames, covers, and classified backfill. All clearing and grubbing, excavation, backfill, compaction, and disposal of unusable material necessary to construct the oil and grit separator, is incidental to this Work item. Foundation backfill, if required, will be paid pursuant to Division 20, Section 20.19 - Furnish Foundation Backfill.

Article 22.5 Basis of Payment

Payment for this Work shall be in accordance with Division 10, Section 10.07 - Measurement and Payment, and shall include full payment for all Work described in this Section.

Payment will be made under the following unit:

ITEM	UNIT
Oil and Grit Separator (Model #)	Each

SECTION 55.23 UNDERGROUND DETENTION AND INFILTRATION SYSTEMS

Article 23.1 General

The Work under this Section consists of performing all operations pertaining to furnishing and installing an underground detention and infiltration chamber system as required by the Drawings and these Specifications.

Contractor shall furnish all labor, materials, equipment, and incidentals necessary to install the system, appurtenances, and incidentals in accordance with the Drawings, these Specifications, and the Manufacturer's requirements.

Article 23.2 Related Standards

ASTM F2418 – Standard Specification for Polypropylene Corrugated Wall Stormwater Collection Chambers.

ASTM F2787 – Standard Practice for Structural Design of Thermoplastic Corrugated Wall Stormwater Collection Chambers.

Article 23.3 Materials

Contractor shall furnish and install a Contech ChamberMaxx underground detention and infiltration chamber system, or an approved equal.

Contech Engineered Solutions
9025 Centre Pointe Drive
West Chester, OH 45069
Phone: 1-800-338-1122

Local Contact:
Contech Engineered Solutions
111 W. 100th Avenue
Anchorage, Alaska 99515
Phone: 907-344-1144
Fax: 907-344-1174.

The chambers shall be constructed of injection molded polypropylene copolymer formulated for high impact and stress cracking resistance and sustained structural performance during high temperatures. The chamber shall be designed and manufactured in accordance with ASTM F2418 and F2787.

The chambers shall be designed to AASHTO LRFD Bridge Design Specifications (Section 12), as applied to material and performance requirements for buried thermoplastic pipes. Design live load shall be the AASHTO HS-20 and HS-25 truck, including multiple lane presence factors, over a minimum cover of 18 inches and chamber row spacing of 5 inches or greater.

Article 23.4 Construction

The Contractor shall participate in an on-site preconstruction meeting with the supplier prior to the scheduled delivery date of the system.

The system shall be installed per the manufacturer/supplier installation instructions, the Drawings, and these Specifications. The Contractor shall carry out the installation in strict accordance with OSHA and manufacturer's safety requirements.

Underground detention and infiltration systems shall be inspected by closed circuit television (CCTV) after completion of backfill and finished grading but prior to the

placement of pavement or other permanent resurfacing, to determine the existence and extent of any obstructions, structural deficiencies, or sags. CCTV shall be performed in accordance with Section 55.25 – Storm Drain Closed Circuit Television Inspections and is incidental to this bid items.

Article 23.5 Measurement

An underground detention and infiltration system is measured as a complete unit in place and shall include the containment row(s), diversion manhole, manifold piping, inspection port, geotextile, scour protection, and classified backfill. All clearing and grubbing, excavation, backfill, compaction, and disposal of unusable material necessary to construct the underground chamber system, is incidental to this Work item.

Article 23.6 Basis of Payment

Payment for this Work shall be in accordance with Division 10, Section 10.07 - Measurement and Payment, and shall include full payment for all Work described in this Section.

Payment shall be made under the following unit:

ITEM	UNIT
Underground Chamber System	Each

SECTION 55.24 THIS SECTION INTENTIONALLY LEFT BLANK

SECTION 55.25 STORM DRAIN CLOSED CIRCUIT TELEVISION INSPECTIONS

Article 25.1 General

The Work under this Section consists of providing all operations associated with video inspection and recording of storm drain assets.

This Work may be required multiple times and at different phases of construction.

New and replaced storm drains twelve inch (12") and greater in diameter shall be inspected by closed circuit television (CCTV) after completion of trench backfill and finished grading but prior to the placement of pavement or permanent trench resurfacing, to determine the existence and extent of any obstructions, structural deficiencies, or sags.

Storm drain pipe being rehabilitated using cured in place pipe lining shall be inspected by CCTV during and after pipe preparation and after lining is completed.

Traffic control may be required to access storm drain manholes, catch basins, catch basin manholes, and other assets. The MOA makes no warranty as to the condition of the pipe, manholes, catch basins, or access points.

Article 25.2 Submittals

Submittals are to be provided to the Engineer for review and acceptance as stated in Division 10, Section 10.05, Article 5.6 – Product Data. Submittals, at a minimum, are to include applicable items identified below:

1. Video
2. CCTV Equipment product data, when requested

Article 25.3 Material

CCTV equipment includes vehicles, computers, software programs, viewing devices, cameras, cables, portable power sources, lights, blowers, winches and all related equipment needed to satisfactorily complete a CCTV inspection.

The camera is to process video in color with a lens having a focal distance between one inch (1") and infinity (∞), be capable of autofocus, manual focus and have an adjustable iris. The in-pipe target is to be viewable with the camera at a perpendicular angle to the target and the camera at zero zoom. For cameras with zoom lens capability, calibration and in-pipe measurements are to be taken at zero zoom. Analog Video output and capture is to be a minimum of 400 lines per inch.

The camera is to be transporter mounted for six inch (6") diameter and larger pipe line inspections, have built in lighting with pan and tilt capabilities of 360° rotation and 270° tilt. Illumination is to be adjustable and capable of providing a clear and well lit picture. Lighting is to be planned and executed based upon the size and type of pipe being inspected.

CCTV performed using digital high-resolution camera(s) equipped with wide angled lens(es) that provide 360 degree spherical and side scanning capabilities that provide "unfolded" views of the pipe, and propelled by a transporter that travels faster than 30 feet per minute, may be used as an alternative to a pan and tilt camera / transporter.

This alternative will only be used if the contractor can comply with all other requirements of this specification section.

Pole mounted cameras may be used to video storm structures and pipe connections.

All in-pipe equipment is to be certified to operate in conditions found in wet/submerged storm drain pipes and manholes without adverse effects to the equipment or the storm drain system. Typically this will require, but not limit, the camera to operate in grease, sludge, mud, gravel, one hundred percent (100%) humidity, and other adverse environments.

Article 25.4 Construction

Where required, the Contractor is to complete a CCTV inspection at the following points of construction;

- Condition Assessment – The primary goal of this inspection is to document the condition of an existing storm drain asset through the use of video and photographic documentation. This information will assist engineers and planners to plan and prioritize any needed repairs.
- Pre-rehabilitation – This inspection takes place during or after pipe preparation and prior to the rehabilitation of a storm drain asset. The video is used to ensure that the pipe is ready for rehabilitation and to look for places that may interfere with the planned rehabilitation. The video and photographic documentation is to be provided to the Engineer for review prior to beginning rehabilitation.
- Prior to Acceptance of New Pipe – Prior to acceptance of newly installed pipe, a CCTV inspection is performed to look for deficiencies in the work. If no deficiencies are found, the CCTV of storm drain pipe is to set baseline condition of the newly installed pipe from which future CCTV inspections will be used to document changes in the condition of the pipe.
- Post rehabilitation – This inspection takes place after rehabilitation of the pipe has been accomplished and will be used to determine Substantial Completion.
- Rehabilitation acceptance – This inspection will take place approximately one month prior to the end of the Warranty Period. It is the responsibility of the Contractor to request CCTV of the rehabilitated storm drain asset. The Warranty will be automatically extended to 30 days past the Rehabilitation Acceptance CCTV or Warranty expiration date, whichever is later.

The Contractor shall notify the Engineer two (2) working days in advance of the anticipated date of the televising. The Engineer or their designee is to be provided unobstructed access to CCTV facilities from set up to tear down of the CCTV equipment. During the CCTV inspection the Engineer or their designee may require the Contractor to backup, adjust the camera and investigate with the CCTV equipment any points they may deem of interest.

The Engineer will review the CCTV video to determine conformance with the specification. The Contractor is to correct deficiencies where the video does not meet the standards stated herein at no additional cost to the Owner.

A. Storm Drain Main CCTV Inspection

The camera is to be centered in the pipe and move in a downstream direction at a uniform rate stopping and recording all joints and points of coding. At no time is the rate to exceed a rate of thirty feet per minute (30 ft/min), unless using the digital high-resolution camera identified as an alternative in Article 25.3. When the camera is not able to complete the inspection, after several attempts and cleaning of the storm drain pipe, then the inspection of the current segment is to be abandoned and started from a reverse setup going against the storm drain flow.

The camera lens is to be kept clear of condensation, oils, grease and debris during the CCTV inspection. Lighting intensity is to be adjusted to minimize glare. Picture quality shall be adjusted to provide a clear in-focus picture of the entire periphery of the pipeline.

The Contractor is to complete a thorough examination of stopping points prior to continuing the inspection. The following partial list of required stopping points are provided below:

- Manholes - Pipe penetrations and barrel sections are to be videoed.
- Joints – camera shall rotate 360° to provide a potential view of all portions of the joint. The rotation is to occur at a metered rate over no less than twenty seconds.
- Cracks and fractures – provide a close up view of the point of interested (POI) and a perspective view indicating the extent and/or length of the POI and how close the nearest pipe joint is.
- Holes, breaks, lining failures and/or deformations – provide a close up and perspective view of the POI. Adjust the view to make apparent any voids behind the POI.
- Lateral connections – inspect the hole cut into the pipe and associated repairs at all lateral connections.
- Changes in alignment, sags or crests – The view should be long enough and lit such that the change can be estimated.

B. Storm Drain Cleaning

When the storm drain line to be inspected by CCTV is slated to be rehabilitated, the pipe cleaning process identified in Section 55.26 shall be followed.

In all other circumstances, the Contractor is to clean the storm drain lines by removing grit, loose solids, grease, and any debris that is present. Debris is to be trapped at the end of the CCTV inspection run and properly hauled off and disposed.

Storm drain line cleaning is to be accomplished using a high velocity jet or mechanically powered equipment. Selection of the equipment used is to be based on the condition of the storm drain line at the time the work commences.

The Contractor is to take due care to avoid damaging the pipe or impact lateral connections.

Cleaning is to be completed by the Contractor within 144 hours and no less than one hour prior to inspection.

C. Flow Control

CCTV video will not be accepted when the water depth is greater than twenty-five percent (25%) of the pipe diameter.

Flow control is required for the successful completion of the CCTV inspection. The Contractor is to schedule inspections at low flow times, assist with a high velocity hydraulic jet, provide storm drain flow control or any combination of the above to meet the water depth requirement.

D. Distance Measurement

The distance shall be measured between the exit of the start structure and the entrance of the finish structure for a true measurement of the length of the pipe segment. It shall be recorded in standard units and the video display readout shall display units to one-tenth of a foot. The camera cable shall be retracted to remove slack to ensure an accurate footage reading. The cable footage counter is to be accurate to the nearest third of a foot (1/3').

E. Deliverables

A minimum of two digital photos are to be taken of each defect, one showing a perspective view and one showing a close-up view. The photo is to have on-screen information such as the distance into the inspection, the starting asset number and the ending asset number.

The Contractor is to submit to the Engineer within five days of completing the CCTV inspection video files, photographs, and the storm drain inspection database. Photographs, video, folders, and other data will be properly referenced within the contractor's database.

The data may be provided on CD's, DVD's, USB Thumb Drives, or portable hard drive. The data shall include the following:

	Data View	Audio	Written
Report No.	X		X
Date of CCTV inspection	X	X	X
Current weather conditions	X		X
MOA Storm Drain Grid page number	X		X
Upstream and downstream manhole structure numbers, storm drain access point or station numbers.	X	X	X
GPS coordinate locations for upstream and downstream manholes and/or any other storm drain access points. GPS receivers shall provide sub-meter accuracy	X		X
Location, size, type, and length of pipe.	X	X	X

	Data View	Audio	Written
Direction of flow and measurement ("From" manhole/storm drain access point/station number "To" manhole/storm drain access point/station number)			X
Tape Counter Footage (current distance along reach)	X		Beginning & End
Sketch showing the street and cross streets where the TV inspection was made			X
Description and location of each defect		X	X
Description and location of each connection		X	X

Recorded images showing steam, inadequate lighting, or poor image quality will be cause for rejection. Rejected recordings will be rerecorded by the Contractor at no additional cost to the Owner.

If the Engineer determines that corrections are needed, the documentation is to be resubmitted after corrective action has taken place.

Article 25.5 Measurement

CCTV measurement is not to overlap and is to occur once per bid item under which it is being paid for regardless of the number of times the CCTV camera views any one piece of pipe during that pay item. Measurement of footage is to be based on footage counter shown in the video.

Article 25.6 Basis of Payment

Payment for this Work shall be in accordance with Division 10, Section 10.07 - Measurement and Payment, and shall include full payment for all Work described in this Section.

Payment includes all labor, tools, equipment, apparatus and incidentals required to complete the Work. At a minimum, no additional payment will be granted for setups, reverse setups, tear downs, relocation, overlapping video footage per bid item, lost or damaged equipment, property owner coordination, and jetting during CCTV activities. Pipe cleaning in preparation for CCTV is incidental unless required for the Prepare Pipe for Lining bid item, in which case the Work is paid under that bid item. Storm drain flow control is considered incidental, unless provided for as a bid item.

Acceptance of new pipe CCTV is incidental to the bid item Furnish & Install Pipe or Furnish & Install Subdrain.

Payment shall be made under the following units:

ITEM	UNIT
Condition Assessment CCTV	Linear Foot
Pre-rehabilitation CCTV	Linear Foot
Post Rehabilitation CCTV	Linear Foot
Rehabilitation Acceptance CCTV	Linear Foot

SECTION 55.26 CURED IN PLACE PIPE (CIPP) LINING

Article 26.1 Description

The Work under this Section consists of the performance of all operations pertaining to preparing the storm drain pipe for the installation of the lining system, furnishing and installing a cured in place pipe (CIPP) lining system for storm drain pipe rehabilitation, and the subsequent Warranty Close-out Inspection, all in accordance with the pipe lining system manufacturer's recommendations and industry standards.

The Work shall include the performance of a closed-circuit television inspection, including DVD recording of the pre-lining pipe condition, providing all operations pertaining to pipe cleaning, the removal of all intruding pipe ends, intruding pipe material, and other obstructions and deleterious material, within the pipe cross-section and throughout the full length of the pipe, which may interfere with the installation or service performance of the lining system, and any other preparatory Work recommended by the lining system manufacturer and industry standards.

The Contractor shall furnish all labor, materials, and equipment for doing the Work including storm drain line cleaning, storm drain flow control and pipe lining installation. The CIPP shall meet the requirements of ASTM F1216 or ASTM F1743 or ASTM F2019. The CIPP shall extend the full length of the host pipe being rehabilitated and shall provide a structurally sound, impermeable, jointless, close-fitting pipe that when cured is mechanically fixed inside the host pipe. If applicable, removal and replacement of the existing host pipe in those areas shown on the drawings shall be accomplished before the liner is inserted.

Polyvinyl Chloride (PVC) fold and form pipe liner installed per ASTM F1504, ASTM F1867, or ASTM F1871 will not be acceptable.

Article 26.2 Submittals

Submit the following for review and approval by the Engineer:

1. Product information for the lining system materials, methods of repair and SDS's for all materials used.
2. Calculations showing that the lining thickness and strength has been designed to meet the requirements of this specification.
3. Verification of the pipe diameters in the Drawings
4. Material sample test results including soil cell testing, chemical resistance, SDR, creep and long-term structural loading tests.
5. Sampling and testing plan for the CIPP.
6. Installers proof of manufacturer's certification.
7. Information confirming that the pipe conforms to the requirements of the Materials Section of this Specification.
8. Submit documented evidence of the ability and capacity of the CIPP installer to perform this work. Submit the name and qualifications of the senior installation supervisor who will be on the project whenever lining materials are

being handled, impregnated with resin, or installed. The senior installation supervisor shall have installed a minimum of 3,000 feet of similar CIPP liner of the same CIPP system in storm drains. If the Contractor does not have a senior installation supervisor that meets these requirements, the Contractor shall provide a manufacturer's representative who is qualified in the CIPP lining work at the project site for the first seven (7) days of CIPP installation while the first two sections of liner is being installed in the host pipe. Contractor shall submit evidence of the manufacturer representative's experience and qualifications for approval by the Engineer prior to the site visit.

Article 26.3 Materials

The hydraulic capacity of the lined pipes shall equal or exceed 100% of the original unlined pipe.

A. Felt or Fiberglass Tube

The tube shall consist of one or more layers of flexible, needled felt or an equivalent woven and/or non-woven material capable of carrying resin, withstanding installation pressures and curing temperatures and compatible with the resin system used. The felt tube shall meet the requirements of ASTM D5813.

Fiberglass tubing shall consist of at least two separate tubes made of corrosion resistant (E-CR) glass fibers in accordance with ASTM D578. The fiberglass tube shall meet the requirements of ASTM F2019.

B. Resin/Catalyst

The contractor shall furnish an ultraviolet (UV) or thermosetting polyester or vinylester resin compatible with the approved liner and a compatible catalyst system as specified by the resin manufacturer. The resin manufacturer shall provide the Contractor with their recommended curing cycle and shall submit the same to the Engineer for approval.

C. Structural Requirements

Design Criteria: The cured in place pipe thickness shall be calculated per ASTM F1216, Appendix X.1 The cured-in-place-pipe thickness shall be calculated and designed based upon the following physical condition of the existing pipe to be rehabilitated.

1. Pipes shall be considered partially or fully deteriorated, as indicated on the drawings or special provisions.
2. All pipes shall be considered to have a depth of bury as provided in the Contract Documents. If not provided, use no less than five feet (5').
3. All pipes shall be subject to a water table as provided in the Contract Documents. If not provided, use not less than two feet (2') above the invert of the pipe.
4. All pipes shall have a minimum of 5% ovality reduction factor in the circumference.
5. A factor of safety of not less than 2.0 shall be applied.

6. The enhancement factor K shall not be higher than 7.
7. The CIPP shall have a wall thickness that is no less than 10 percent (10%) larger than the minimum calculated design thickness.

D. Mechanical Properties

The CIPP when cured shall have the following minimum values when tested in accordance with ASTM F1216 by an independent testing laboratory:

1. Flexural Strength (tested in accordance with ASTM D790) 4,500 psi
2. Flexural Modulus (tested in accordance with ASTM D790) 250,000 psi
3. Chemical Resistance Meet Minimum Requirements of ASTM F1216, Table X2.1

Article 26.4 Construction

A. General

The Contractor shall carry out this operation in strict accordance with all OSHA and manufacturer's safety requirements. Particular attention is drawn to those safety requirements involving working with scaffolding, entering confined spaces and operations with hot media.

The Contractor shall take all necessary precautions and actions to prevent debris from entering the pipe. Contractor shall remove any debris that enters the system due to construction, including the downstream system.

B. Storm Drain Pipe and Structure Cleaning

The designated storm pipe sections from storm structure to storm structure shall be cleaned using high velocity jet, or mechanically powered equipment. Selection of the equipment used shall be based on the condition of the storm pipes and structures at the time the Work commences. The equipment shall be capable of removing dirt, grease, rocks, sand, pipe coating debris and other materials and obstructions from the storm pipes and structures. If cleaning of an entire section cannot be successfully performed from one structure, the equipment shall be set up on the other structure and cleaning again attempted.

During cleaning operations, satisfactory precautions shall be taken in the use of cleaning equipment. Care shall be exercised to avoid damage to the pipes and structures during cleaning. If the bottom of the pipe is corroded or missing, the cleaning process shall be limited to getting the bottom smooth enough to allow the pre-lining CCTV and to support the lining operation. Extra caution shall be used to ensure that the Contractor does not wash away material that is outside the diameter of the existing pipe section. If the Contractor operation results in a significant wash-out, the Contractor shall import classified material to fix the wash-out. Repair of the wash-out, including placement and the cost of the imported material, is incidental to the Work and no separate payment is made.

The Contractor shall be responsible for and repair, at no cost to the Owner, any damage to a structurally sound (no cracks, breaks or loss of pipe wall thickness) storm pipe caused by use of the cleaning equipment. Further, the Contractor shall

be responsible for any damage to properties connected to the storm drain which result from the pipe cleaning operation.

Cleaning shall be performed to a level required so that television inspection and storm drain pipe rehabilitation can be properly accomplished. Contractor may use CCTV to monitor work during the cleaning of the storm drain pipe to determine whether the pipe is sufficiently cleaned, at which point the Contractor shall CCTV the pipe in accordance with Section 55.25 – Storm Drain Closed Circuit Television Inspections and provide a copy to the Engineer for final acceptance of the storm drain pipe cleaning. If television inspection shows the cleaning to be unsatisfactory, the Contractor shall be required to re-clean and re-inspect the storm drain line by television inspection until the cleaning is shown to be satisfactory, at no additional cost to the Owner.

If the Contractor wishes to use AWWU water for this work, the Contractor shall obtain a hydrant permit from AWWU prior to obtaining water from any hydrant. Any damage to the hydrant or water system resulting from misuse or work not in compliance with the fire hydrant permit by the Contractor shall be repaired by the Contractor at no cost to the Owner.

C. Material Removal and Disposal

All sludge, dirt, sand, rocks, grease, and other solid or semisolid material resulting from the cleaning operation shall be removed at the downstream structure of the section being cleaned. Passing material from structure to structure will not be permitted. Collected material shall be disposed of by the Contractor in accordance with Division 10, Section 10.04, Article 4.9 – Disposal Sites. Disposal of the collected material is incidental to the Work and no separate payment is made.

D. Pre-Lining Inspection

The Contractor shall inspect the storm drain pipe immediately before the insertion of the impregnated tube to assure that the pipe is clean and existing pipe conditions are acceptable for lining.

Inspection of pipes shall be performed by experienced personnel trained in locating breaks, obstacles, and lateral connections by closed-circuit television, completed in accordance with Section 55.25 – Storm Drain Closed Circuit Television Inspections. The interior of the pipe shall be carefully inspected to determine the location of any conditions which may prevent proper installation of the pipe lining, and it shall be noted so that these conditions can be corrected. Immediately after the inspection is complete, the Contractor shall provide the Engineer with an inspection recording and suitable log for later reference.

If the pre-insertion video inspection reveals an obstruction in the existing pipe (heavy solids, dropped joint, collapsed pipe, etc.) that cannot be removed with conventional pipe cleaning equipment, then the Contractor shall contact Engineer immediately to determine how to deal with the obstruction.

E. Bypass Storm Flows

Contractor shall bypass storm drain flows in accordance with Article 26.5, SubArticle A – Bypass Storm Flows.

F. Resin Impregnation

The Contractor shall designate a location where the felt tube will be impregnated with resin, using distribution rollers and vacuum, to thoroughly saturate the felt tube prior to its dispatch for installation. A catalyst system or additive(s) compatible with the resin and tube may be used per the manufacturer's recommendation. However, they shall not impair or reduce the resin's ability to withstand the minimum chemical resistance or load bearing criteria. The quantity of resin used for tube impregnation shall be sufficient to fill the volume of air voids in the tube with additional allowances for polymerization shrinkage and the loss of resin through cracks and irregularities in the original pipe wall.

G. Installation

If an additional sleeve or tube is required for liner protection, the Contractor shall install it per the manufacturer's recommendations prior to pipe lining.

The wetted out tube shall be transported and protected until it is inserted through an existing structure. The insertion area, equipment platform, etc., shall be securely protected, and all damaged structures shall be repaired by the Contractor.

The CIPP shall be installed in accordance with ASTM F1216 or ASTM F1743. Care shall be taken not to overstress the felt or fiberglass tube at the elevated curing temperatures, which may cause damage or failure prior to cure.

H. Curing

After completion of the insertion, the Contractor shall follow manufacturer's recommended curing method. The Contractor shall use a hot water recirculation, steam system, or ultraviolet light (depending on the requirements described below), capable of delivering a consistent cure of the resin.

The Contractor shall be responsible for moving or conveying water to the work area. The curing temperature shall be as recommended by the resin manufacturer.

For water or steam cure, the heat source shall be fitted with suitable monitors to gauge the temperature of the outgoing and incoming curing water or steam. Another such gauge shall be placed between the impregnated tube and the invert to the original pipe at all manholes along the length of the liner (including intermediate manholes) to determine the temperatures during the resin curing process. Initial cure may be considered completed when the exposed portions of the felt tube pipe appear to be hard, and the remote sensing device indicates the temperatures to be adequate, as recommended by the resin/catalyst system manufacturer. Curing temperatures and duration shall comply with previously submitted data and information.

For heat cured CIPP, cool the hardened cured-in-place-pipe to a temperature below one hundred degrees Fahrenheit (100° F) before relieving the internal pressure. Cool down shall be accomplished with water. Careful attention shall be taken not to cool too quickly to eliminate the possibility of thermoshock. Care shall be taken in the release of the internal pressure so that a vacuum will not be

developed that could damage the newly installed liner. Cool down process may vary depending on the installation technique of the manufacturer/Contractor.

For UV cure the Contractor shall provide equipment capable of delivering desired UV light intensity, pressure, and temperature uniformly throughout the liner. The UV light intensity, pressure, and temperature shall be continuously monitored by both computer and video as recommended by the liner manufacturer.

Samples shall be obtained for testing as stated below.

I. Fit/Finish

The finished pipe shall be continuous over the entire length of the storm drain section. The finished liner shall tightly conform to the walls of the existing host pipe. No gap or annular space between the finished liner and the host pipe shall be allowed or be visible at the structure, lateral connection, or other exposed points within the finished liner section. The finished liner shall be homogenous throughout and free of any protrusions, holes, cracks, etc., which in the opinion of the Engineer will affect the liner's structural integrity, hydraulic performance, future maintenance access, and overall line performance.

At liner termination points in manholes, provide a smooth transition from the liner to the existing pipe end. If necessary, grind the exposed liner edge smooth to eliminate rough or abrupt edges that may collect debris or hamper CCTV equipment operation.

J. Reinstatement of Lateral Connections

Reinstate lateral connections, if necessary, using trenchless techniques in accordance with the liner manufacturer's requirements. The Work shall be accomplished from within the storm drain line. Excavation to reinstate lateral connections will not be allowed. Re-opening of the lateral entrances shall be performed in a manner to prevent blockage of flows at the opening. The reinstated connection opening shall be no less than 95 percent and no more than 100 percent of the size of the original connection opening. The reinstated connection shall be smooth and uniform with no rough edges or protrusions along the trimmed edge of the liner that could cause debris to collect at the connection opening. Each reinstated connection shall be thoroughly inspected with the camera during the post rehabilitation CCTV inspection to confirm that the final fit and finish is acceptable. The CCTV inspection will include stopping at each reinstated connection, pausing for 10 seconds and view the entire circumference of the reinstated connection.

If the Contractor cuts through the liner outside of the lateral connection to be reinstated, the Contractor shall repair the damaged liner at no additional cost to the Owner.

K. Clean Up

After the installation Work has been completed and all testing accepted, the Contractor shall clean up the entire project area. The Contractor shall dispose of all excess material and debris not incorporated into the permanent installation.

L. Sampling and Testing

Sampling and testing shall meet the requirements of ASTM F-1216 or ASTM F-1743. Deviations from sampling methods described in the appropriate ASTM shall be reviewed and approved or denied in advance of the start of construction. Sampling and testing shall include the following:

1. Prepare a minimum of three CIPP samples from each diameter of liner installed.
2. Samples shall be large enough to provide a minimum of five specimens.
3. Test for initial tangent flexural modulus of elasticity and flexural stress in accordance with ASTM D790 and meet the requirements of Article 26.3, SubArticle D. Mechanical Properties within this specification.
4. Verify that the liner thickness of the sample meets the requirements of this specification.
5. Submit test results to the Engineer for review and approval.

M. Post-Rehabilitation Television Inspection

After the liner is inserted and lateral connections have been reinstated, the Contractor shall complete a television inspection of the CIPP and submit the video and log to the Engineer for review. The final television inspection shall conform to Section 55.25 – Storm Drain Closed Circuit Television Inspections and to the requirements of this Specification. The entire circumference of the liner and each reinstated lateral connection shall be observed during the television inspection. The Contractor shall by-pass or temporarily block the storm drain flow in accordance with Article 26.5, SubArticle A – Bypass Storm Flows, if necessary to achieve this condition. The entire circumference of the liner shall be readily visible with the television camera.

N. Final Acceptance

The final acceptance for the liner will be based on visual observation results of the post-rehabilitation television inspection and satisfactory sampling and testing results. During the post-rehabilitation television inspection, the Engineer will examine the pipe wall for deformation or damage. The Contractor shall correct deformations and reinspect as required by the Engineer.

Article 26.5 Work Incidental to CIPP

A. Bypass Storm Flows

The Contractor shall bypass the storm flows around those sections of pipe designated for rehabilitation on an as-required basis.

Prior to construction, the Contractor shall submit to the Engineer a plan detailing the scheduled deployment of pumps, hoses, and other equipment necessary to maintain storm flows during construction. The Contractor shall ensure that pumping systems shall be of sufficient capacity to handle existing flow plus additional flow that may occur during a rainstorm for the duration of all operations requiring such bypass. A minimum of 500 gpm capacity will be required for bypass pumping but flows can be expected as large as 2700 gpm during storm events.

The Contractor shall provide a primary bypass pump in good working order and reliable or provide a standby pump of the same or equal capacity that is connected into the bypass piping system and immediately ready for operation. The pumping system shall be such that the hydraulic gradient both upstream and downstream of the piping being bypassed will not reach elevations that will cause damage to the properties being served. This will require close attention to the elevation of the upstream head needed to actuate the pumping cycle and the rate of discharge flow from the pumps. Under no circumstances shall the Contractor allow the discharge of storm water on the ground.

If pumping is required on a 24-hour basis, engines shall be equipped in a manner to keep noise to a minimum and the Contractor shall provide full-time, 24-hour monitoring and observation of the bypass pump when bypass pumping is occurring.

The Contractor is reminded that after-hours pumping may require a permit to exceed the allowable noise levels. Should such a permit not be available for certain locations, such lack of availability shall not be cause for a claim for additional compensation or time extension.

The Contractor shall be liable for all damages which result from storm drainage flows not properly maintained during the progress of the Work, including damages to private property which occur as a direct or indirect result of inadequate control of the storm drainage flows while the storm drainage bypass operation is ongoing.

All Work as described in this SubArticle, including bypass pumping of existing storm flows and all dewatering operations/efforts associated with rehabilitation of existing storm drain pipe, shall be incidental to the project and no separate payment shall be made.

B. Disposal of Water Generated by Lining Operations

Contractor is responsible for obtaining all necessary permits for disposal of water generated during lining operations. Contractor shall collect and dispose of all water generated during lining operations around those section(s) of pipe designated for rehabilitation on an as-required basis.

Prior to construction, Contractor shall submit to the Engineer a plan detailing the necessary permits acquired and the method of collecting and disposing of water generated during lining operations.

Contractor's methods for collection and disposal of water generated from pipe preparation and lining operations shall comply with the current Municipality of Anchorage MS4 Permit (Permit No. AKS-052558) and the current ADEC Standards including, but not limited to, the Alaska Water Quality Standards (18 AAC 70) and Alaska Water Quality Criteria Manual for Toxic and Other Deleterious Organic and Inorganic Substances. For more information refer to the following website:

<https://dec.alaska.gov/water/water-quality/standards>

All Work as described in this SubArticle, including collection and disposal of all water generated during lining operations and obtaining all necessary permits, shall be incidental to this project and no separate payment shall be made.

Article 26.6 Measurement

Measurement for preparing pipe for lining shall be based on actual length of pipe on a linear foot basis without respect to pipe diameter. Closed-circuit television inspection of the pipe including delivery of the DVD to the Engineer is incidental to this pay item and no additional payment shall be made.

Measurement for all sizes of lining pipe shall be based on the horizontal distances and will be for actual linear footage for liner installed in the field and shall be measured between the pipe ends along the length of the pipe.

Measurement for reinstatement of lateral connections shall be per each.

Article 26.7 Basis of Payment

Payment for this Work shall be in accordance with M.A.S.S. Section 10.07 Measurement and Payment as amended in these specifications and shall include full payment for all Work as described in this Section.

Payment for furnishing and installing CIPP liner includes furnishing all materials and performing the Work specified in this Section, including liner, resin, storm drain line cleaning and preparation, sampling and testing, and sealing the liner in the manholes.

Payment for reinstating lateral connections shall constitute full payment for furnishing labor and equipment required to reinstate lateral connections shown in the drawings.

Unit cost payment shall be made on the following basis:

ITEM	UNIT
Prepare Pipe for Lining	Linear Foot
Furnish and Install CIPP Liner (Diameter)	Linear Foot
Reinstate Lateral Connection	Each

**MUNICIPALITY OF ANCHORAGE
STANDARD SPECIFICATIONS**

**DIVISION 55
STORM DRAIN SYSTEMS
STANDARD DETAILS**

**STANDARD CONSTRUCTION SPECIFICATIONS
DIVISION 55
INDEX OF STANDARD DETAILS**

- 55-1 CPEP Storm Pipe Connection
- 55-2 Corrugated Metal Pipe Band
- 55-3 Subdrain / Perforated Storm Mains
- 55-4 Storm Drain Manhole Type I - Pipe \leq 24"
- 55-5 Storm Drain Manhole Type II - 24" to 36"
- 55-6 Storm Drain Manhole Type III
- 55-7 Storm Drain Manhole Cover
- 55-8 Storm Drain Top Intake Cover
- 55-9 Storm Drain Beehive Intake Cover
- 55-10 Manhole Heights
- 55-11 Precast Concrete Reducing Slab (72" or 48" to 26")
- 55-12 Precast Concrete Reducing Slab (72" to 48")
- 55-13 Precast Concrete Two Hole Reducing Slab (72" to two 25 1/2")
- 55-14 Precast Concrete Reducing Slab (112" to 72")
- 55-15 Precast Concrete Reducing Slab (140" to 72")
- 55-16 Precast Concrete Reducing Slab (168" to 72")
- 55-17 Manhole Cone Adjustment
- 55-18 Manhole Ring Adjustment
- 55-19 Curb Inlet Frame and Hood for Type 1 Curb and Gutter
- 55-20 Curb Inlet Grates for Type 1 Curb and Gutter
- 55-21 Curb Inlet for Type 2 Curb and Gutter
- 55-22 Precast Catch Basin
- 55-23 Storm Drain Cleanout
- 55-24 Storm Drain Drop Connection (2' Min Drop)
- 55-25 Storm Drain Drop Connection (4' Min Drop)
- 55-26 Footing Drain Service
- 55-27 Driveway Culvert Details
- 55-28 Dual Entry Manhole
- 55-29A Oil and Grit Separator Bypass
- 55-29B Oil and Grit Separator Bypass Manhole

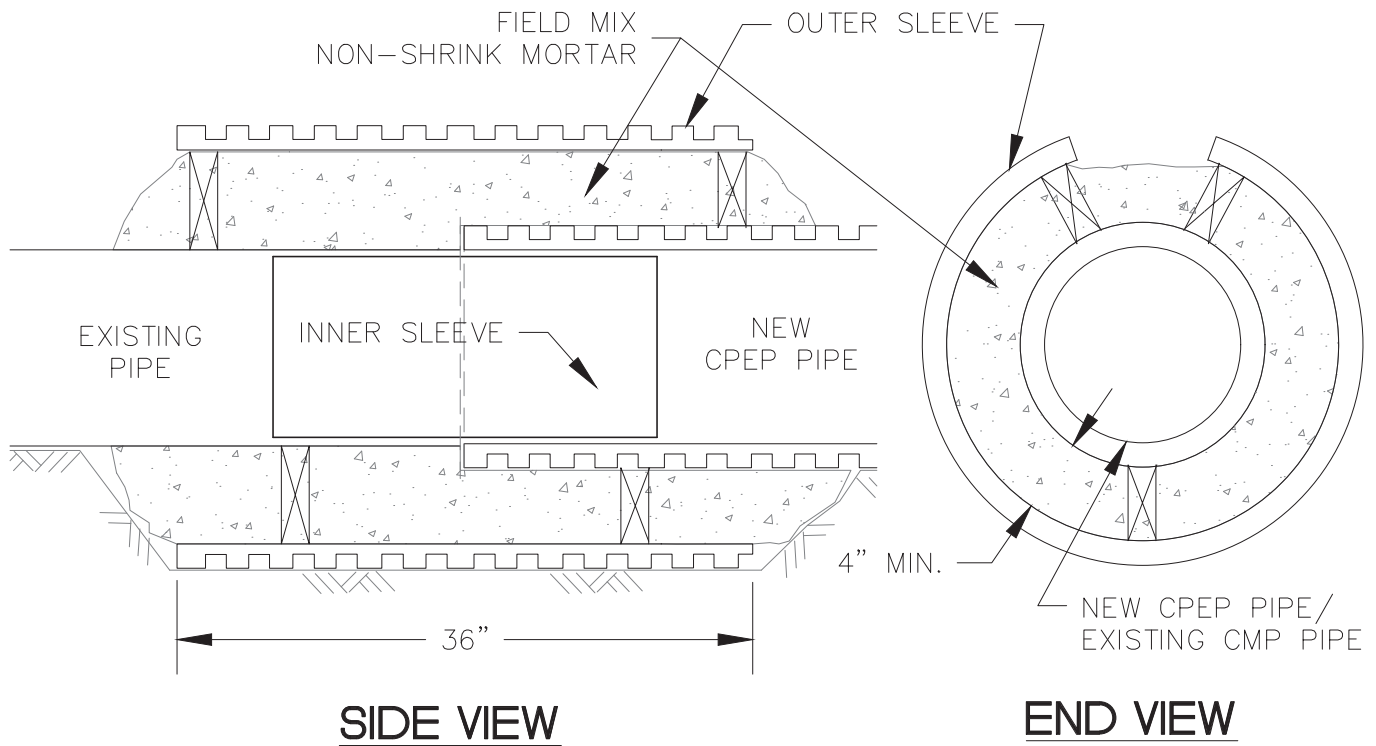

SIDE VIEW

END VIEW

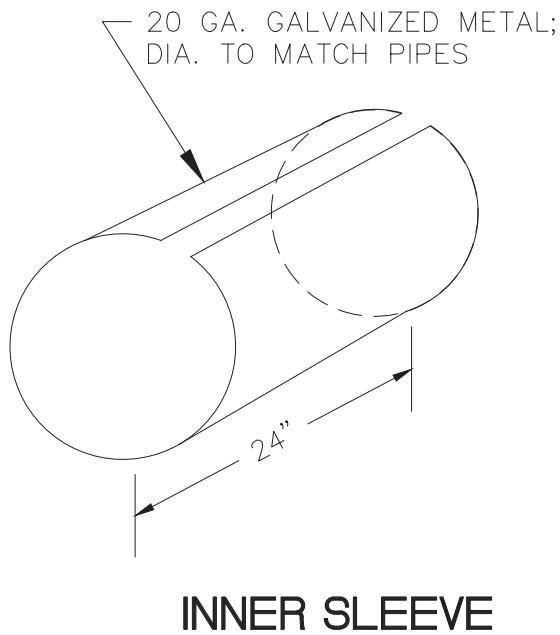

NOTE:

1. MATCH INVERTS OF EXISTING PIPE AND NEW CPEP PIPE. INNER SLEEVE SHALL FORM A SMOOTH TRANSITION, WITHOUT AN ABRUPT EDGE WITH NEW CPEP PIPE AND EXISTING CMP PIPE.
2. INSTALL 24" LONG INNER SLEEVE.
3. INSTALL A 36" LONG OUTER SLEEVE, CENTER ON JOINT, AS A CONCRETE FORM.
4. FILL OUTER SLEEVE WITH NON-SHRINK MORTAR.
5. USE POTABLE WATER IN MINIMUM AMOUNTS TO PROVIDE PLASTICITY IN PLACING THE MORTAR.
6. BACKFILL AND COMPACT TRENCH.

 <p>MUNICIPALITY OF ANCHORAGE</p>	<p>SCALE: N.T.S.</p> <p>APPROVED:</p> <p>REVISED: 2/24</p>	<p>CPEP STORM PIPE CONNECTION</p>	<p>SECTION # 55.02</p> <p>DETAIL # 55-1</p>
--	--	--	---

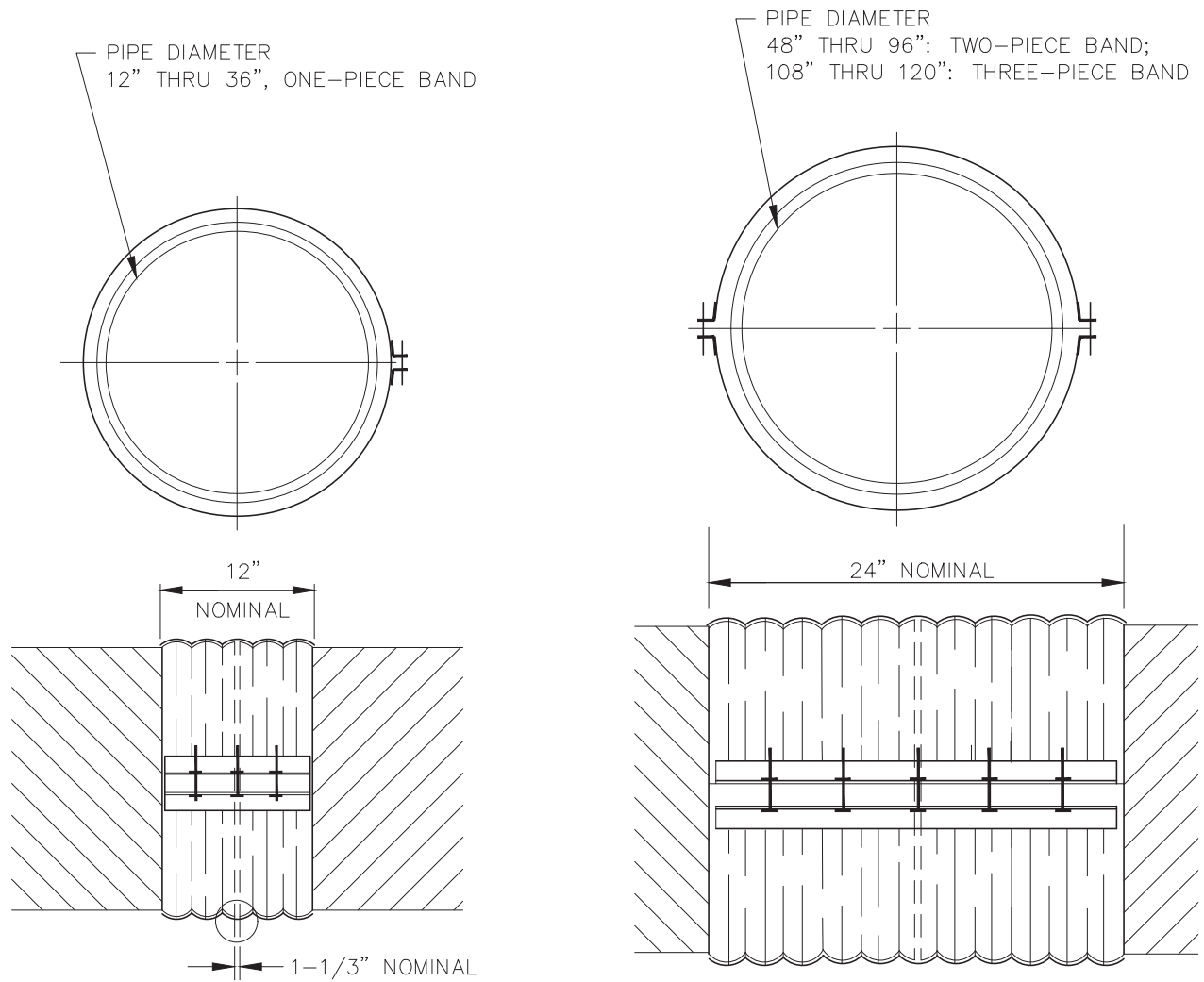

NOTE:

1. 12" THRU 36" PIPE ENDS RE-CORRUGATED TO ANNULAR (2 VALLEYS MIN. PER END).
2. 48" THRU 120" PIPE ENDS RE-CORRUGATED TO ANNULAR (4 VALLEYS MIN. PER END).
3. BAND ANGLES TO BE 2"x2"x12" GA. MIN.
4. BAND MATERIAL AND FABRICATION SHALL CONFORM TO AASHTO M-36 AND AASHTO M-218; PROVIDE 16 GAUGE BANDS FOR 12" THRU 120" DIAMETER PIPES.
5. DIMPLED TYPE CONNECTING BANDS ARE ALLOWABLE ONLY WHERE FITTINGS ARE USED IN NEW OR EXISTING CONSTRUCTION, FOR REPAIRS TO DAMAGED CMP, AND FOR EXTENSIONS TO CMP WITHOUT ANNULAR ENDS. SIZE BANDS IN ACCORDANCE WITH ABOVE SCHEDULE (MIN. 12").
6. BOLT SIZE SHOULD BE 1/2" DIAMETER BY 8" LONG. NUTS SHALL BE PROVIDED WITH A WASHER.

 <p>MUNICIPALITY OF ANCHORAGE</p>	<p>SCALE: N.T.S.</p> <p>APPROVED:</p> <p>REVISED: 2/24</p>	<p>CORRUGATED METAL PIPE BAND</p>	<p>SECTION # 55.02</p> <p>DETAIL # 55-2</p>
--	--	--	---

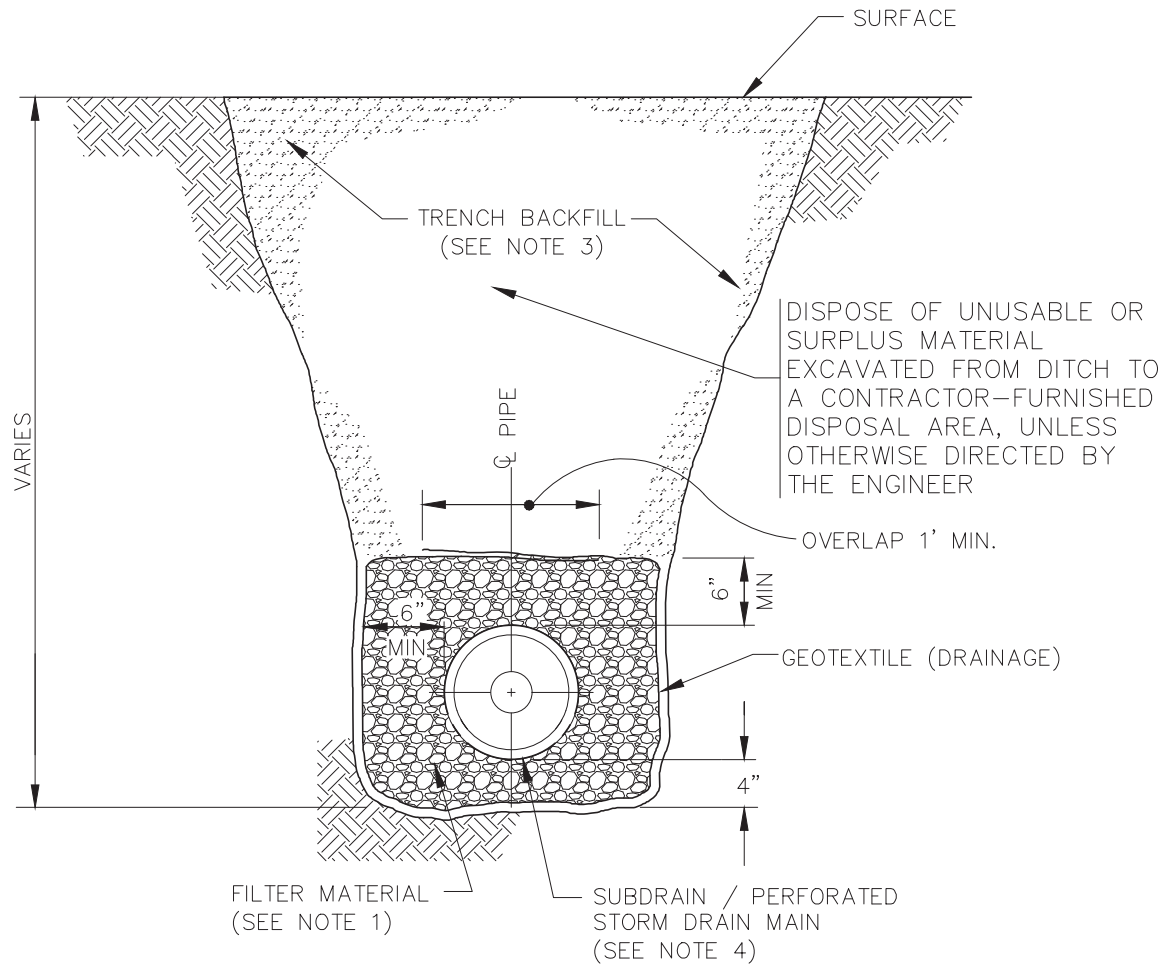

NOTE:

1. PROVIDE FILTER MATERIAL TYPE AS SPECIFIED IN THE CONTRACT DOCUMENTS.
2. COMPACT BACKFILL UNDER THE EXISTING OR PROPOSED ROAD PRISM TO A MINIMUM OF 95% OF MAXIMUM DENSITY.
3. TRENCH BACKFILL SHALL BE CLASSIFIED BACKFILL AS SPECIFIED IN THE DRAWINGS.
4. PERFORATION PATTERN AS SHOWN ON THE DRAWINGS. IF NO PERFORATION PATTERN PROVIDED ON DRAWINGS, USE CLASS 2 PATTERN, EITHER 45° OR 60°, AS SPECIFIED IN THE APPROPRIATE AASHTO STANDARD.

MUNICIPALITY



OF ANCHORAGE

SCALE:
N.T.S.

APPROVED:

REVISED:
2/24

**SUBDRAIN / PERFORATED
STORM MAIN**

SECTION #
55.03

DETAIL #
55-3

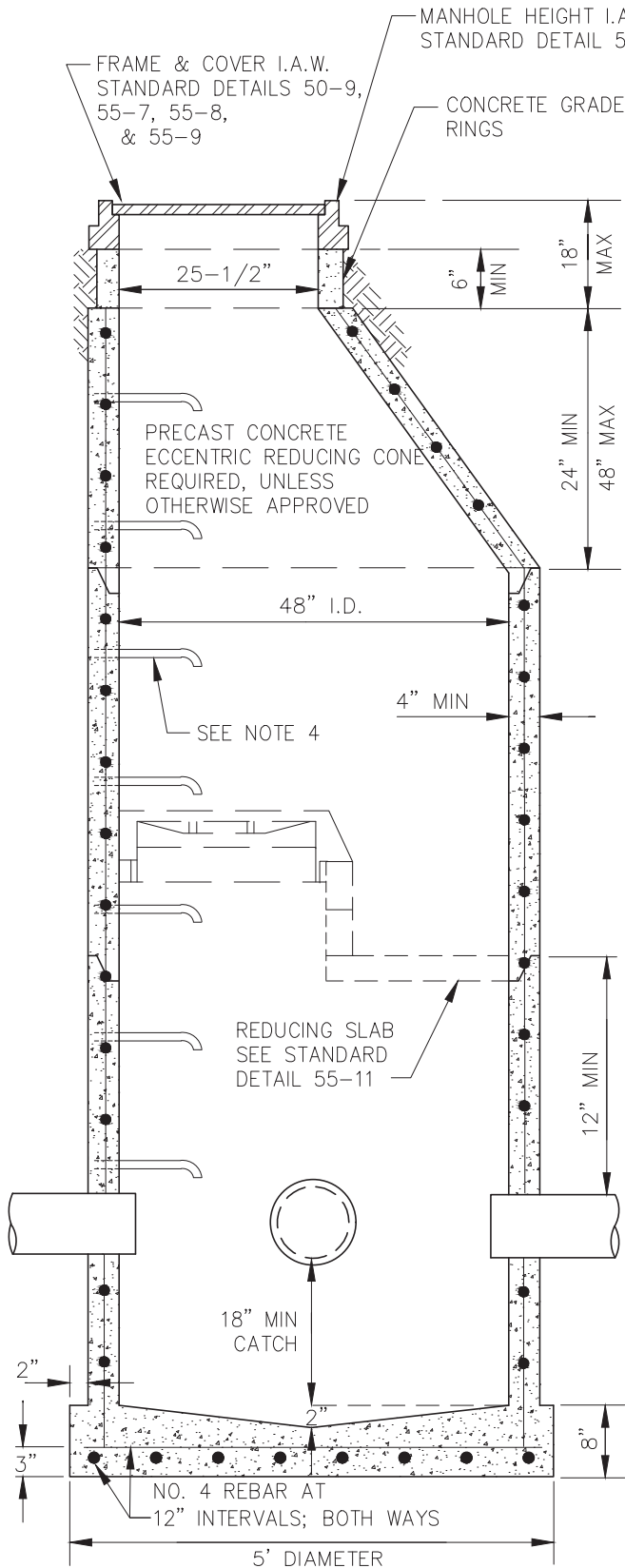

NOTE:

1. MANHOLE SECTIONS SHALL CONFORM TO A.S.T.M. C-478.
2. EXTEND PIPE 2" INTO MANHOLE. SEAL PIPE PENETRATIONS WITH NON-SHRINKABLE GROUT MIXED WITH POTABLE WATER I.A.W. MANUFACTURERS RECOMMENDATIONS.
3. BLOCKOUTS SHALL BE FORMED.
4. PLACE RUNGS 12" ON-CENTER ON UNOBSTRUCTED SIDE OF MANHOLE 18" MAX. FROM BOTTOM OF MANHOLE & 8" MAX. FROM TOP OF CONE. IF UNOBSTRUCTED SIDE NOT AVAILABLE, BOTTOM RUNG TO BE PLACED 6" OVER SMALLEST PIPE. WHEN USING REDUCING CONE, MAXIMUM DEPTH TO FIRST LADDER RUNG IS 26". WHEN USING FLAT SINGLE ACCESS LIDS, THE MAXIMUM DEPTH TO THE FIRST LADDER RUNG IS 30". SEE MANHOLE STEP STANDARD DETAIL 50-6.
5. MANHOLE SHALL HAVE MINIMUM OF ONE 6" GRADE RING.
6. BACKFILL AROUND MANHOLE WITH A MINIMUM OF 3' TYPE II CLASSIFIED FILL & BACKFILL. BACKFILL SHALL BE INCIDENTAL TO COST OF MANHOLE INSTALLATION.
7. CATCH BASIN LEADS SHALL ENTER THE MANHOLE AT LEAST ONE PRIMARY LEAD DIAMETER ABOVE THE TOP OF THE PRIMARY LEAD UNLESS MINIMUM PIPE SLOPES CANNOT BE ACHIEVED.
8. STEEL REQ'D FOR BARREL SHALL CONFORM TO A.S.T.M. C-478. EMBED STEEL IN BASE SO THAT FIRST BARREL SECTION IS CONNECTED WITH BASE.
9. "RAM-NEK" OR EQUAL AND PRIME BARREL JOINTS. HEAT "RAM-NEK" AND SEAL SURFACES BEFORE FINAL ASSEMBLY.
10. PRIMARY LEADS NOT TO EXCEED 24" CPEP OR HDPEP WITH INCLUDED ANGLE BETWEEN LEADS GREATER THAN OR EQUAL TO 135°, OR PRIMARY LEADS NOT TO EXCEED 18" CPEP OR HDPEP WITH INCLUDED ANGLE LESS THAN 135°.
11. A TYPE I MANHOLE SHALL NOT BE USED WHEN BOTH CATCH BASIN AND ACCESS FUNCTIONS ARE REQUIRED.

 MUNICIPALITY OF ANCHORAGE	SCALE: N.T.S. APPROVED: REVISED: 2/24	<h2 style="margin: 0;">STORM DRAIN MANHOLE</h2> <h3 style="margin: 0;">TYPE I</h3> <h3 style="margin: 0;">PIPE ≤ 24"</h3>	SECTION # 55.05 DETAIL # 55-4
---	---	---	--

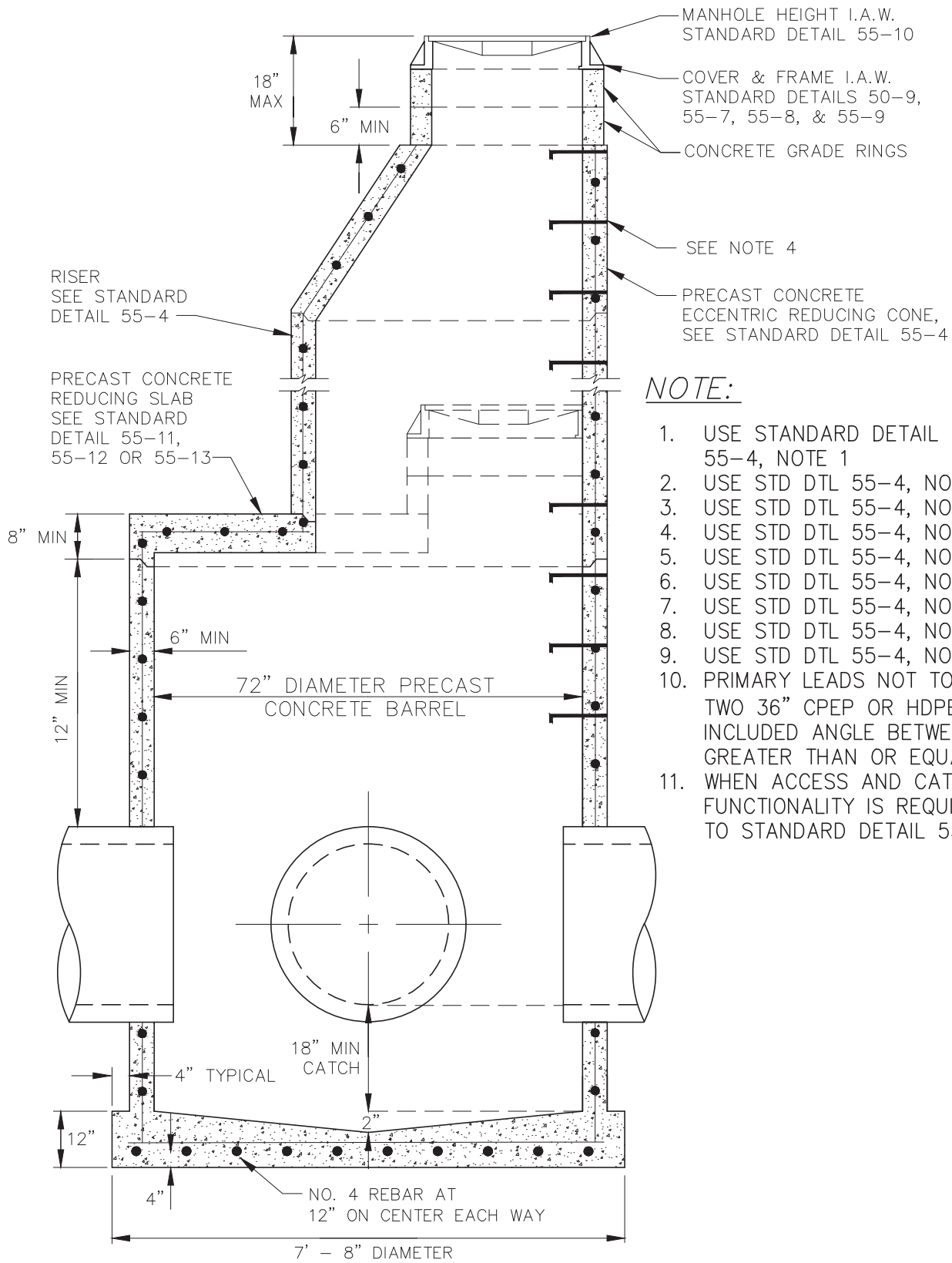

NOTE:

1. USE STANDARD DETAIL (STD DTL) 55-4, NOTE 1
2. USE STD DTL 55-4, NOTE 2
3. USE STD DTL 55-4, NOTE 3
4. USE STD DTL 55-4, NOTE 4
5. USE STD DTL 55-4, NOTE 5
6. USE STD DTL 55-4, NOTE 6
7. USE STD DTL 55-4, NOTE 7
8. USE STD DTL 55-4, NOTE 8
9. USE STD DTL 55-4, NOTE 9
10. PRIMARY LEADS NOT TO EXCEED TWO 36" CPEP OR HDPEP WITH INCLUDED ANGLE BETWEEN LEADS GREATER THAN OR EQUAL TO 135°.
11. WHEN ACCESS AND CATCH BASIN FUNCTIONALITY IS REQUIRED, REFER TO STANDARD DETAIL 55-28.



SCALE:
N.T.S.

APPROVED:

REVISED:
2/24

**STORM DRAIN MANHOLE
TYPE II
24" TO 36"**

SECTION #
55.05

DETAIL #
55-5

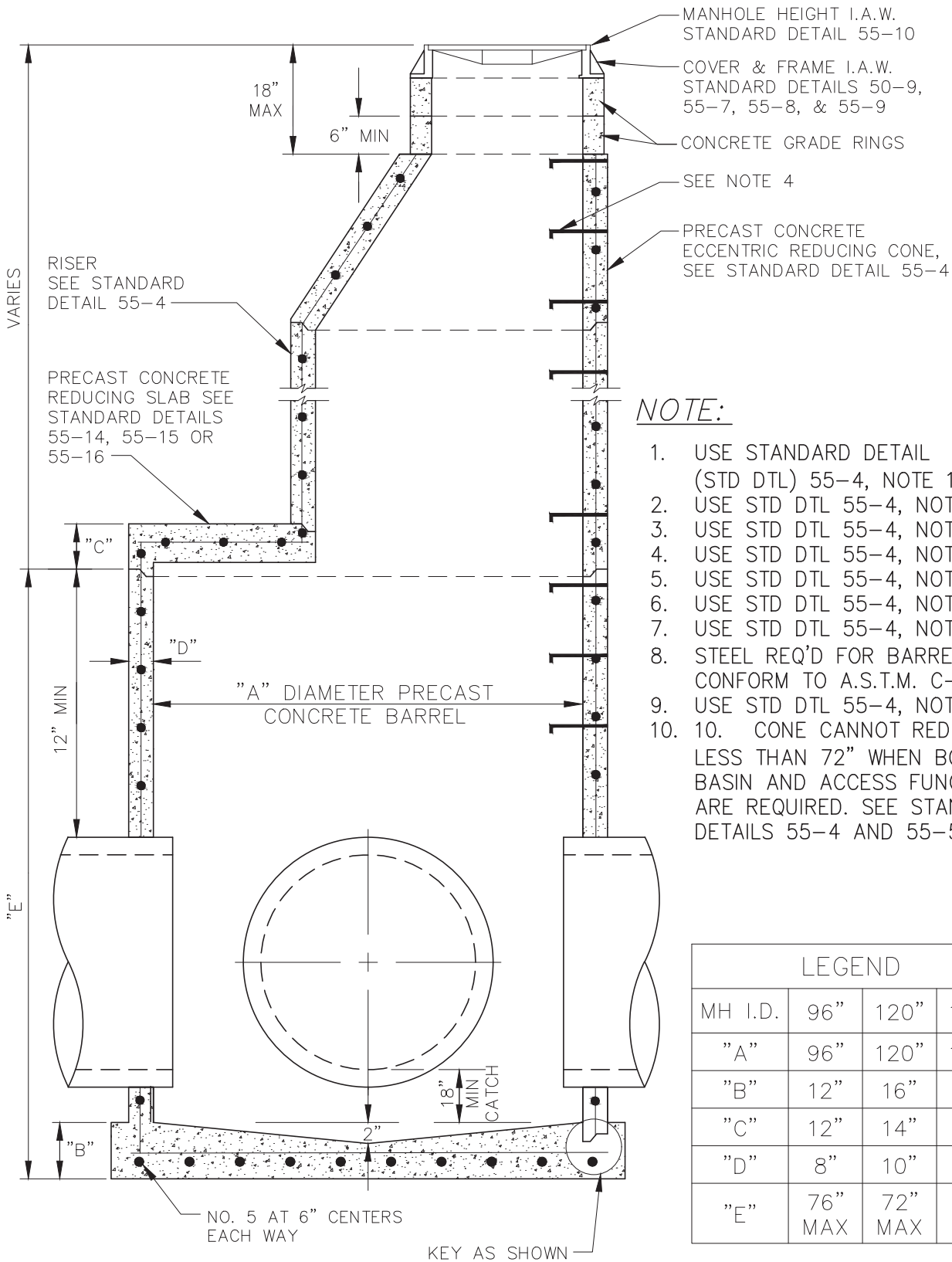

- NOTE:**
1. USE STANDARD DETAIL (STD DTL) 55-4, NOTE 1
 2. USE STD DTL 55-4, NOTE 2
 3. USE STD DTL 55-4, NOTE 3
 4. USE STD DTL 55-4, NOTE 4
 5. USE STD DTL 55-4, NOTE 5
 6. USE STD DTL 55-4, NOTE 6
 7. USE STD DTL 55-4, NOTE 7
 8. STEEL REQ'D FOR BARREL SHALL CONFORM TO A.S.T.M. C-478.
 9. USE STD DTL 55-4, NOTE 9
 10. 10. CONE CANNOT REDUCE TO LESS THAN 72" WHEN BOTH CATCH BASIN AND ACCESS FUNCTIONS ARE REQUIRED. SEE STANDARD DETAILS 55-4 AND 55-5.

LEGEND			
MH I.D.	96"	120"	144"
"A"	96"	120"	144"
"B"	12"	16"	16"
"C"	12"	14"	16"
"D"	8"	10"	12"
"E"	76" MAX	72" MAX	56" MAX



SCALE:
N.T.S.

APPROVED:

REVISED:
2/24

STORM DRAIN MANHOLE TYPE III

SECTION #
55.05

DETAIL #
55-6

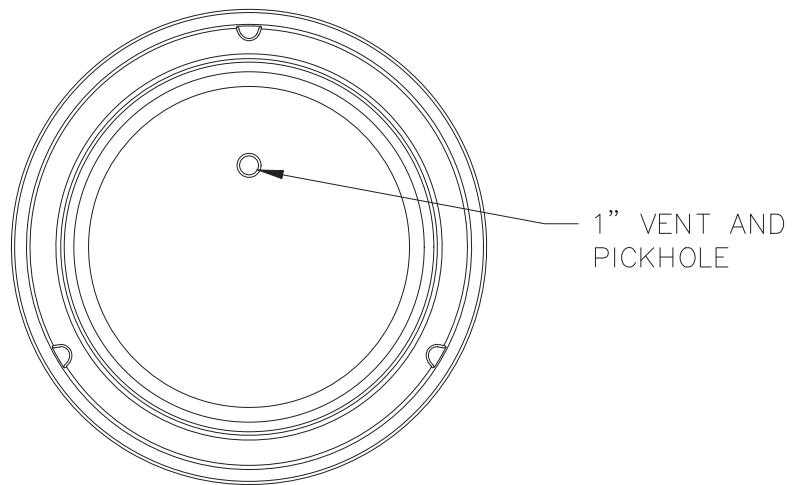
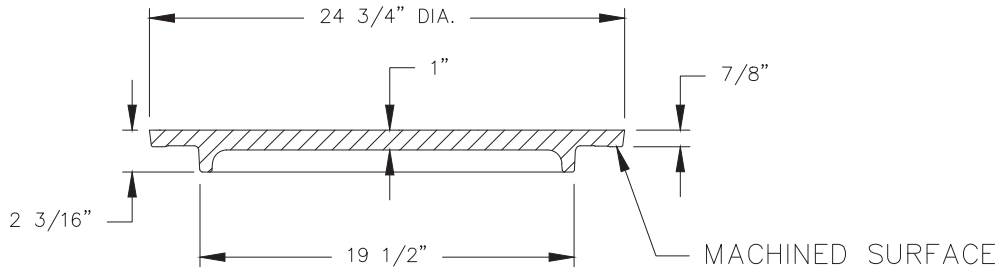
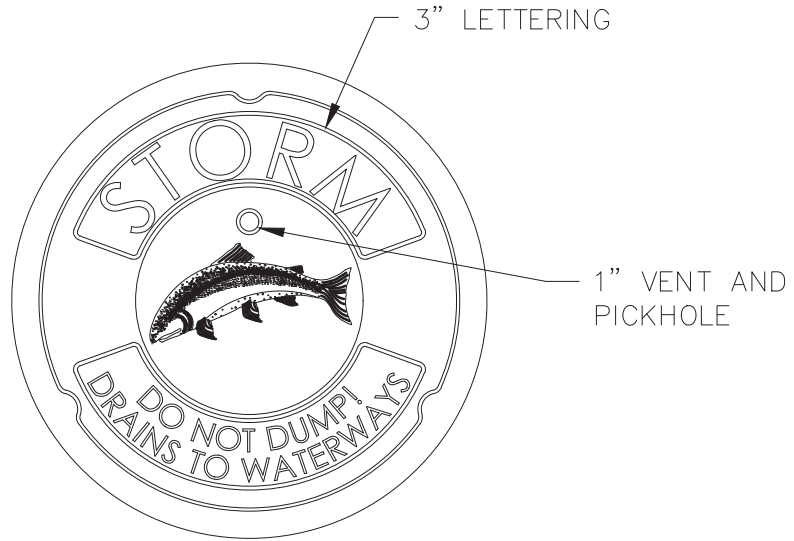

SCALE:
N.T.S.

APPROVED:

REVISED:
2/24

STORM DRAIN MANHOLE COVER

SECTION #
55.05

DETAIL #
55-7

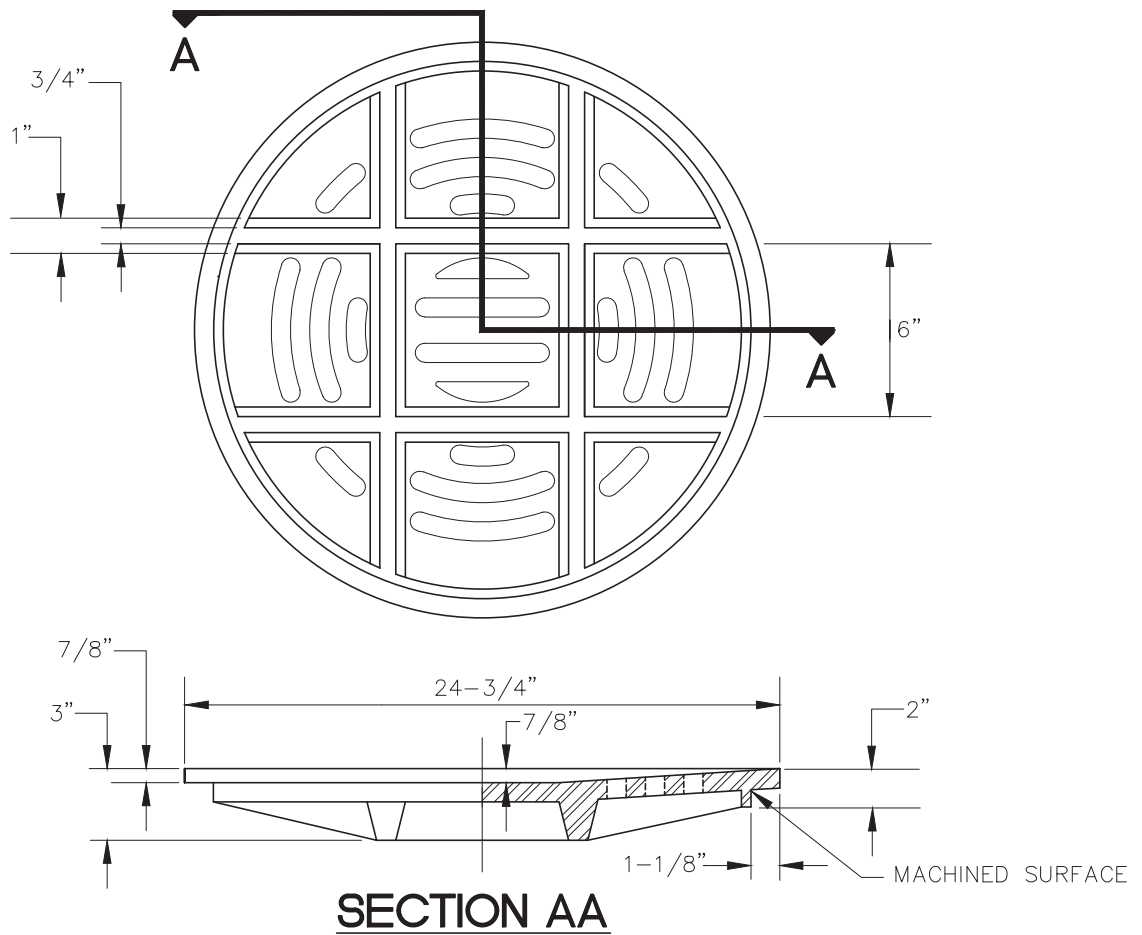

2000 P.S.I. STRENGTH REQUIREMENT
 FOR TRANSVERSE BREAKING LOAD
 PER A.S.T.M. A-438

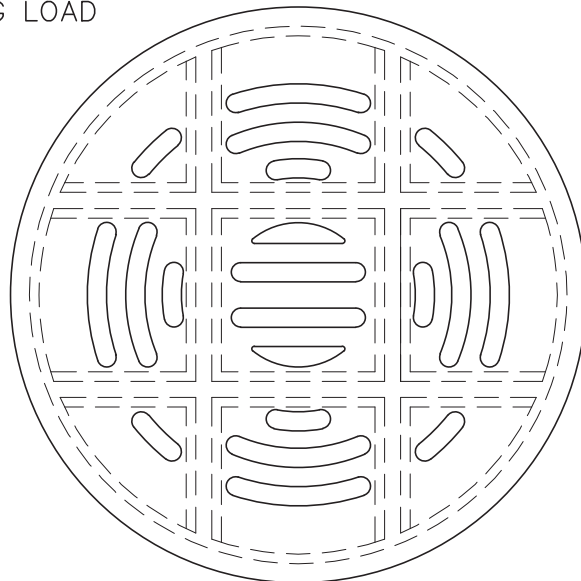

 <p>MUNICIPALITY OF ANCHORAGE</p>	<p>SCALE: N.T.S.</p> <p>APPROVED:</p> <p>REVISED: 2/24</p>	<p>STORM DRAIN TOP INTAKE COVER</p>	<p>SECTION # 55.05</p> <p>DETAIL # 55-8</p>
--	--	--	---

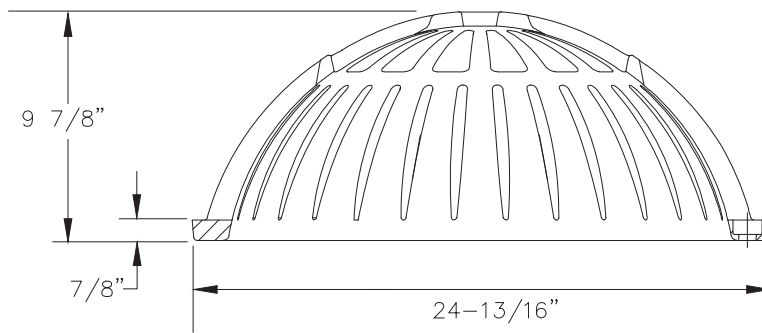
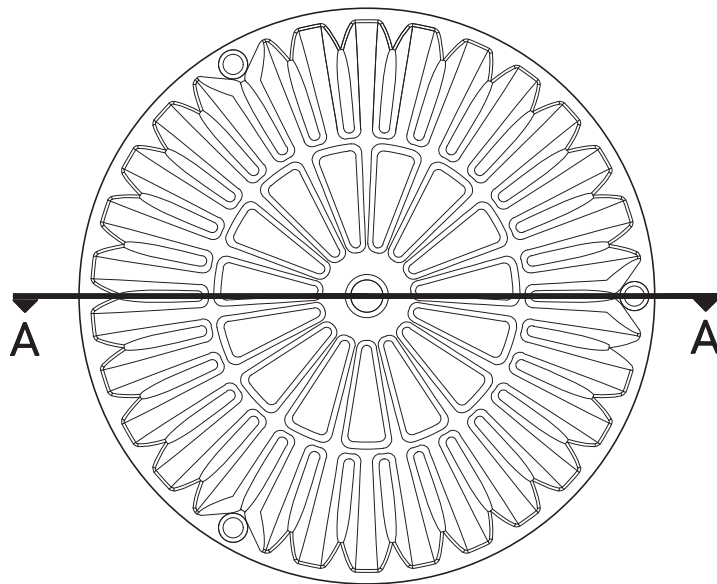

SECTION AA

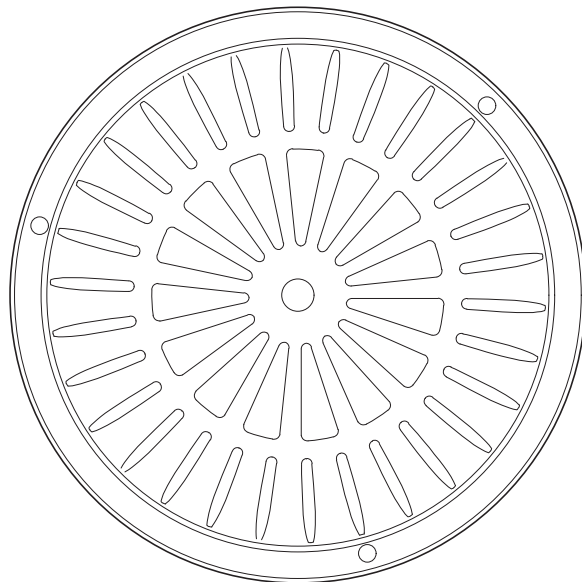

MUNICIPALITY



OF ANCHORAGE

SCALE:
N.T.S.

APPROVED:

REVISED:
2/24

**STORM DRAIN
BEEHIVE INTAKE COVER**

SECTION #
55.05

DETAIL #
55-9

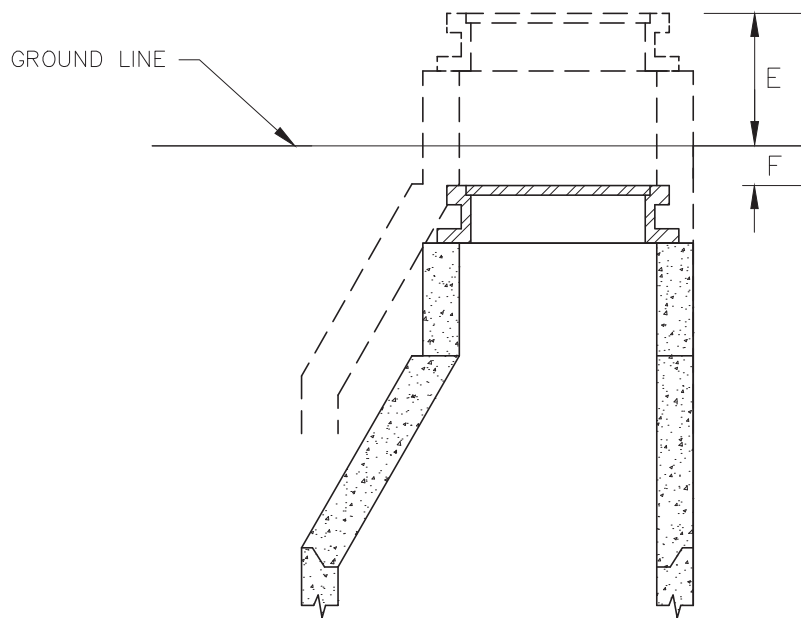

LOCATION	E	F
LANDSCAPED AREAS, GRAVEL STREETS, AND ALLEY AREAS WHERE TRAVELED		0" TO 2"
UNDEVELOPED AND CLASSIFIED WETLAND AREAS ¹	24" TO 36"	
ASPHALT PAVED VEHICLE SURFACES (FEATHER PAVEMENT AT EDGE TO SMOOTH TRANSITION)		1/2" TO 1"
ASPHALT PAVED PEDESTRIAN SURFACES ²		0" TO 1/2"
CONCRETE PAVED SURFACES		0" TO 1/4"

NOTES:

1. MANHOLES WITHIN THE CLEAR ZONE SHALL MEET CLEAR ZONE REQUIREMENTS.
2. PAVEMENT AROUND MANHOLES INSTALLED MORE THAN 1/4" BELOW GRADE SHALL BE BEVELED WITH A SLOPE NOT STEEPER THAN 50 PERCENT.

MUNICIPALITY



OF ANCHORAGE

SCALE:
N.T.S.

APPROVED:

REVISED:
2/24

MANHOLE HEIGHTS

SECTION #
55.05

DETAIL #
55-10

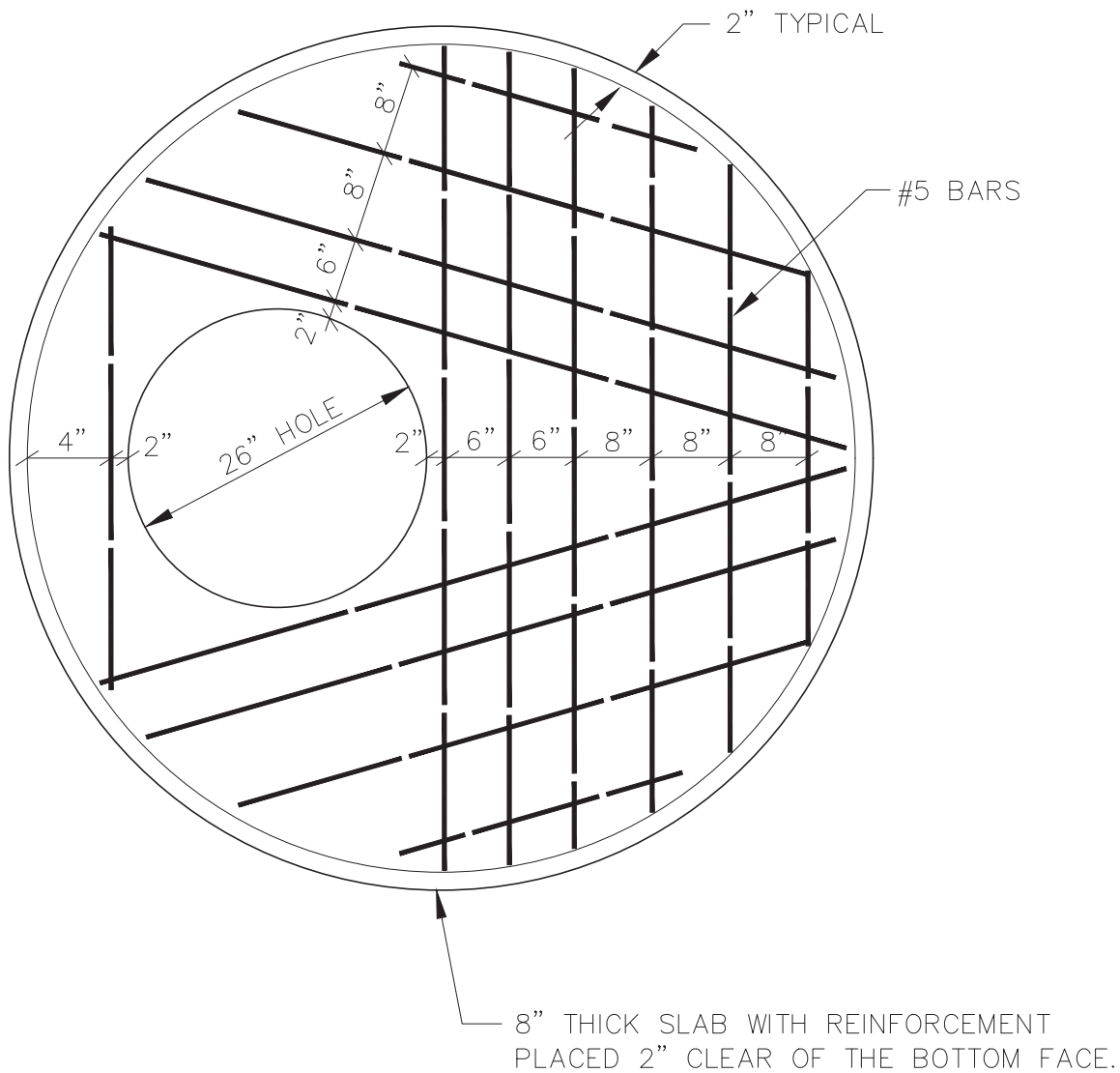

MUNICIPALITY



OF ANCHORAGE

SCALE:
N.T.S.

APPROVED:

REVISED:
2/24

**PRECAST
CONCRETE REDUCING SLAB
(72" OR 48" TO 26")**

SECTION #
55.05

DETAIL #
55-11

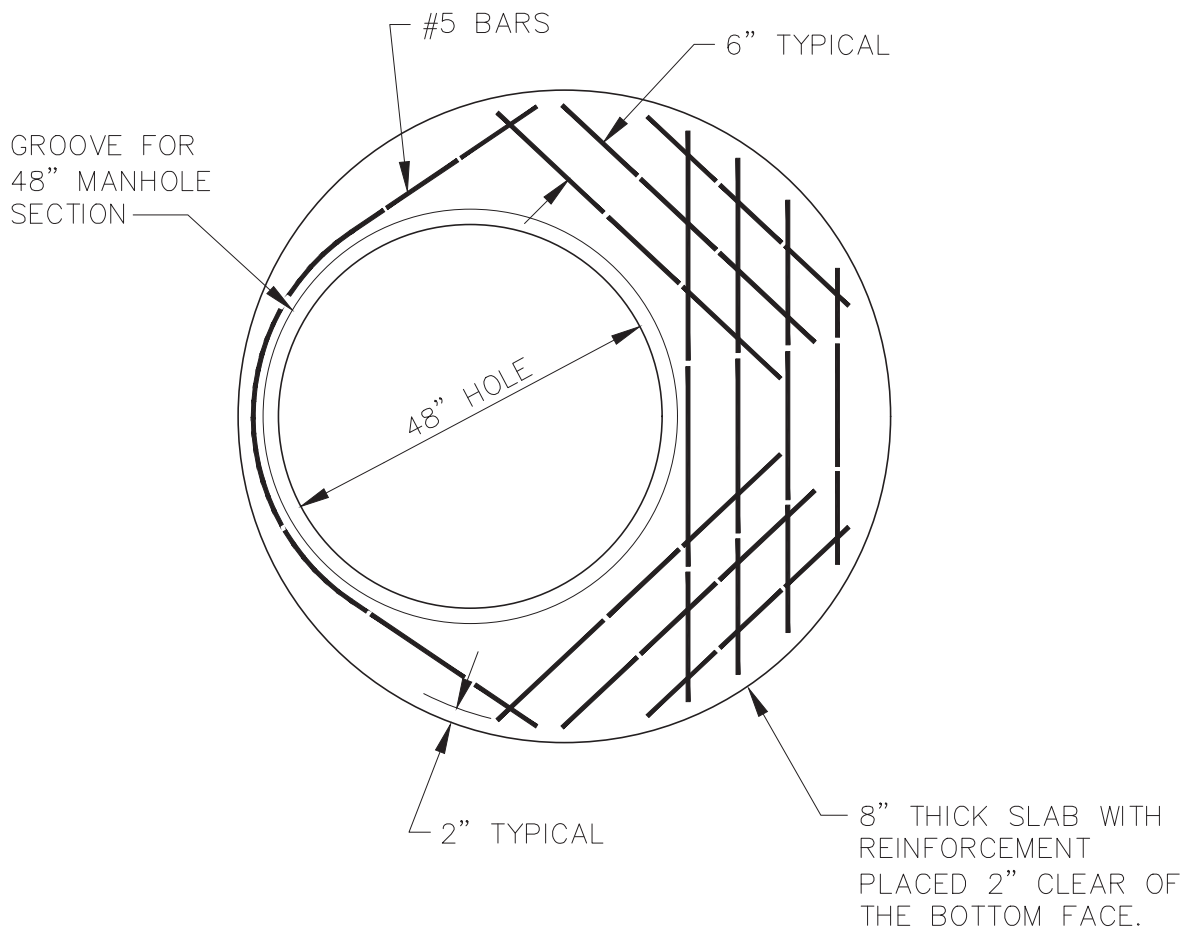

MUNICIPALITY



OF ANCHORAGE

SCALE:
N.T.S.

APPROVED:

REVISED:
2/24

**PRECAST
CONCRETE REDUCING SLAB
(72" TO 48")**

SECTION #
55.05

DETAIL #
55-12

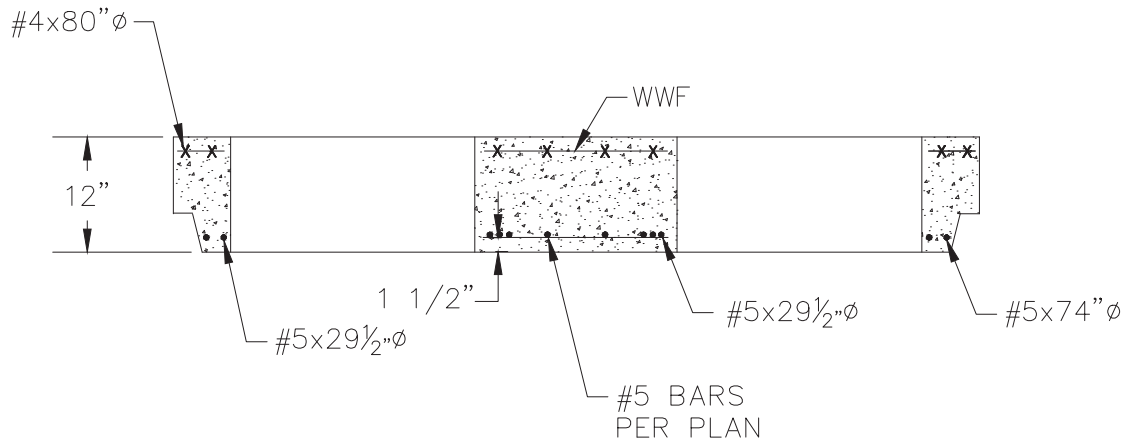
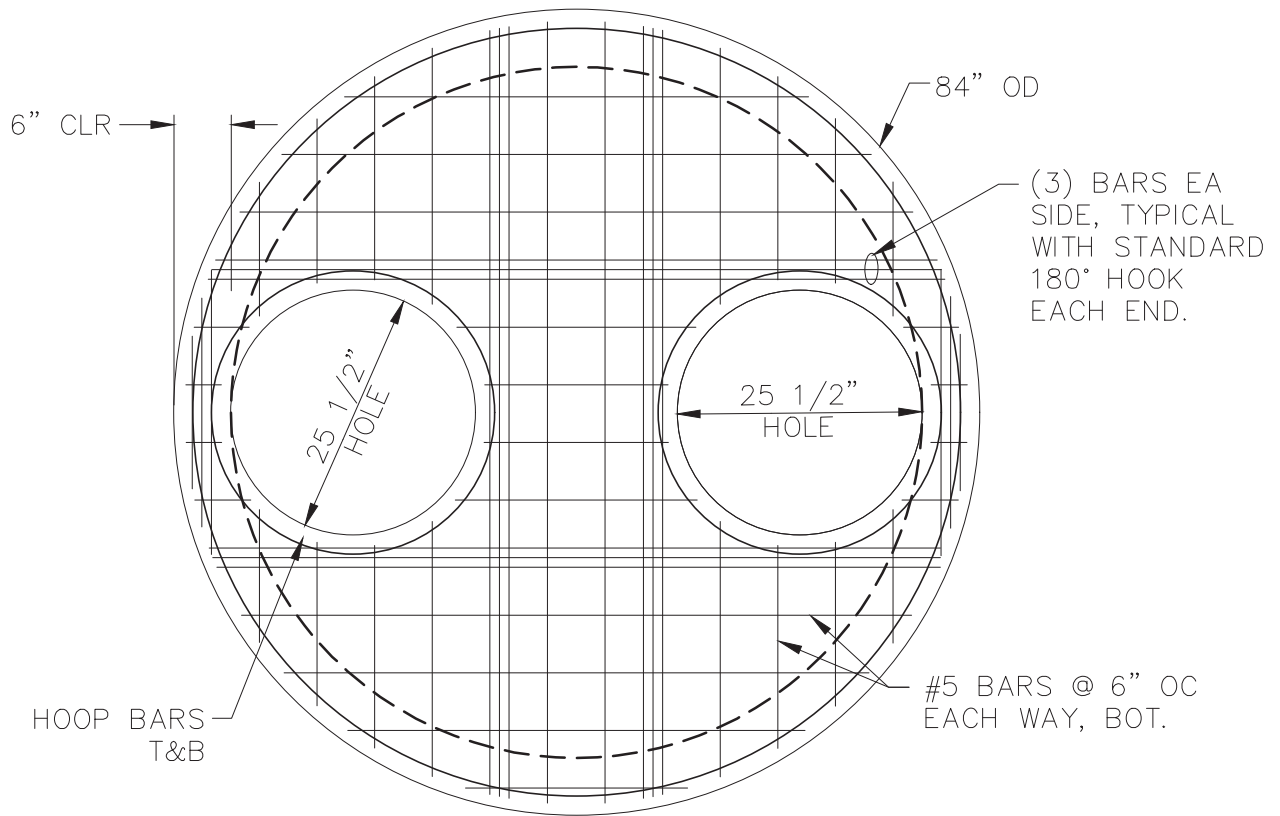

MUNICIPALITY



OF ANCHORAGE

SCALE:
N.T.S.

APPROVED:

REVISED:
2/24

PRECAST CONCRETE TWO HOLE REDUCING SLAB (72" TO TWO 25 1/2")

SECTION #
55.05

DETAIL #
55-13

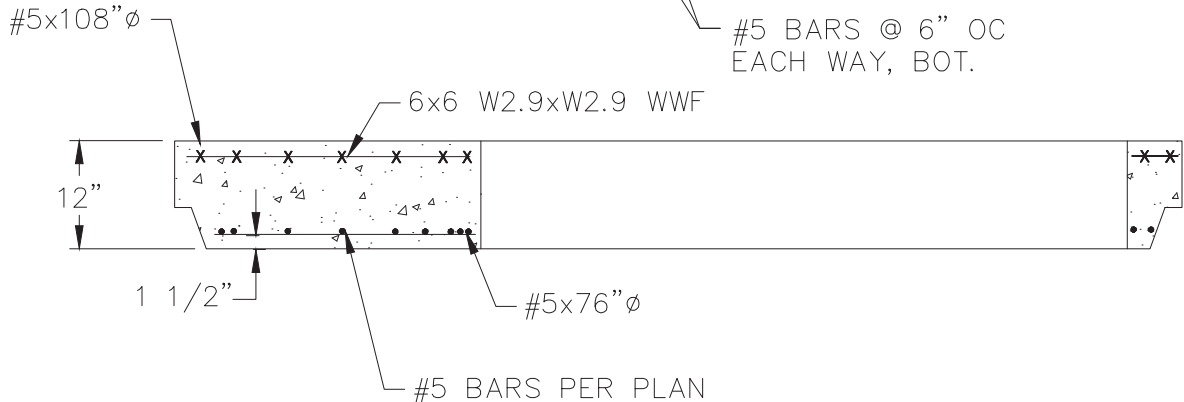
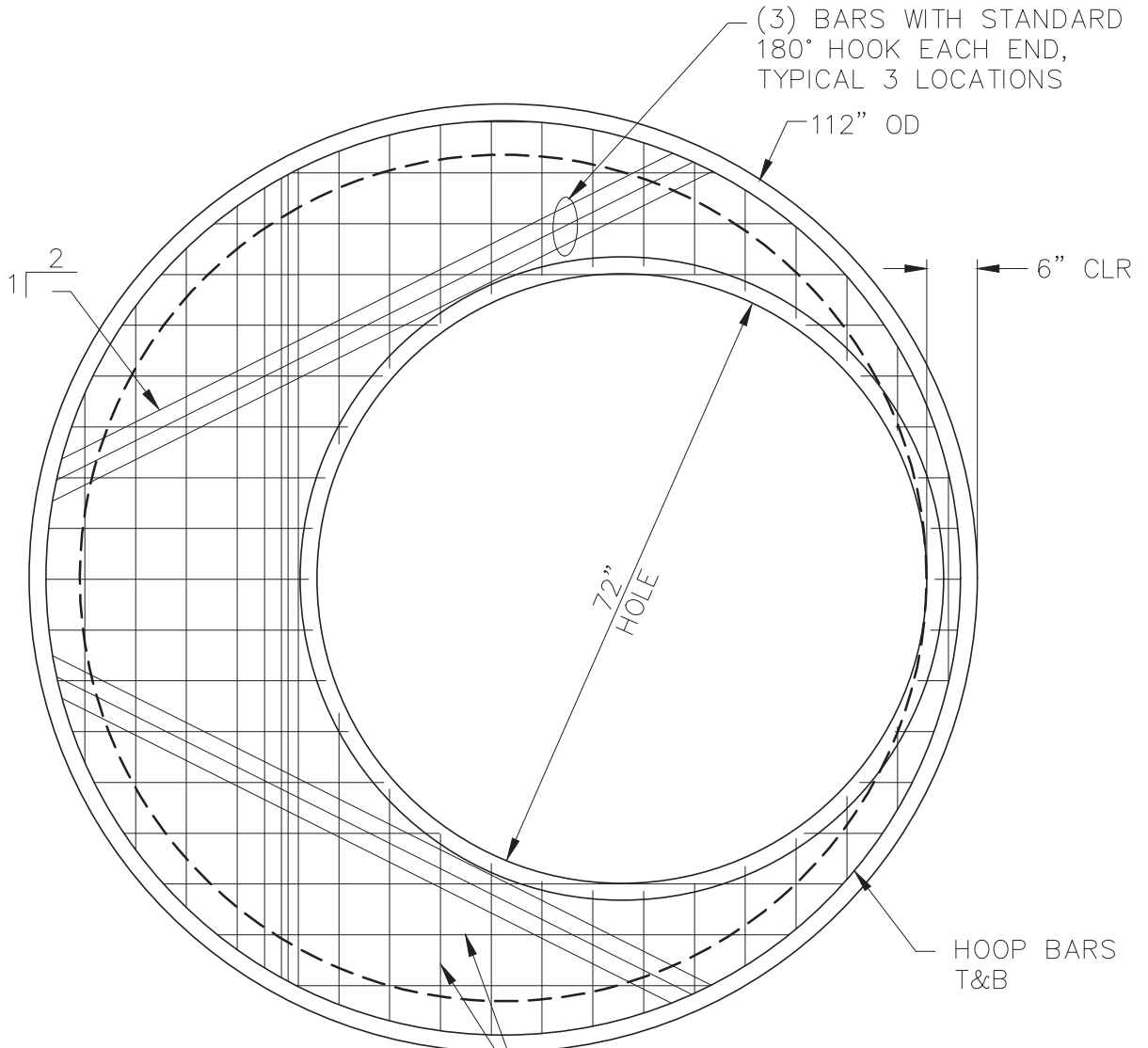

 <p>MUNICIPALITY OF ANCHORAGE</p>	<p>SCALE: N.T.S.</p> <p>APPROVED:</p> <p>REVISED: 2/24</p>	<p>PRECAST CONCRETE REDUCING SLAB (112" TO 72")</p>	<p>SECTION # 55.05</p> <p>DETAIL # 55-14</p>
--	--	--	--

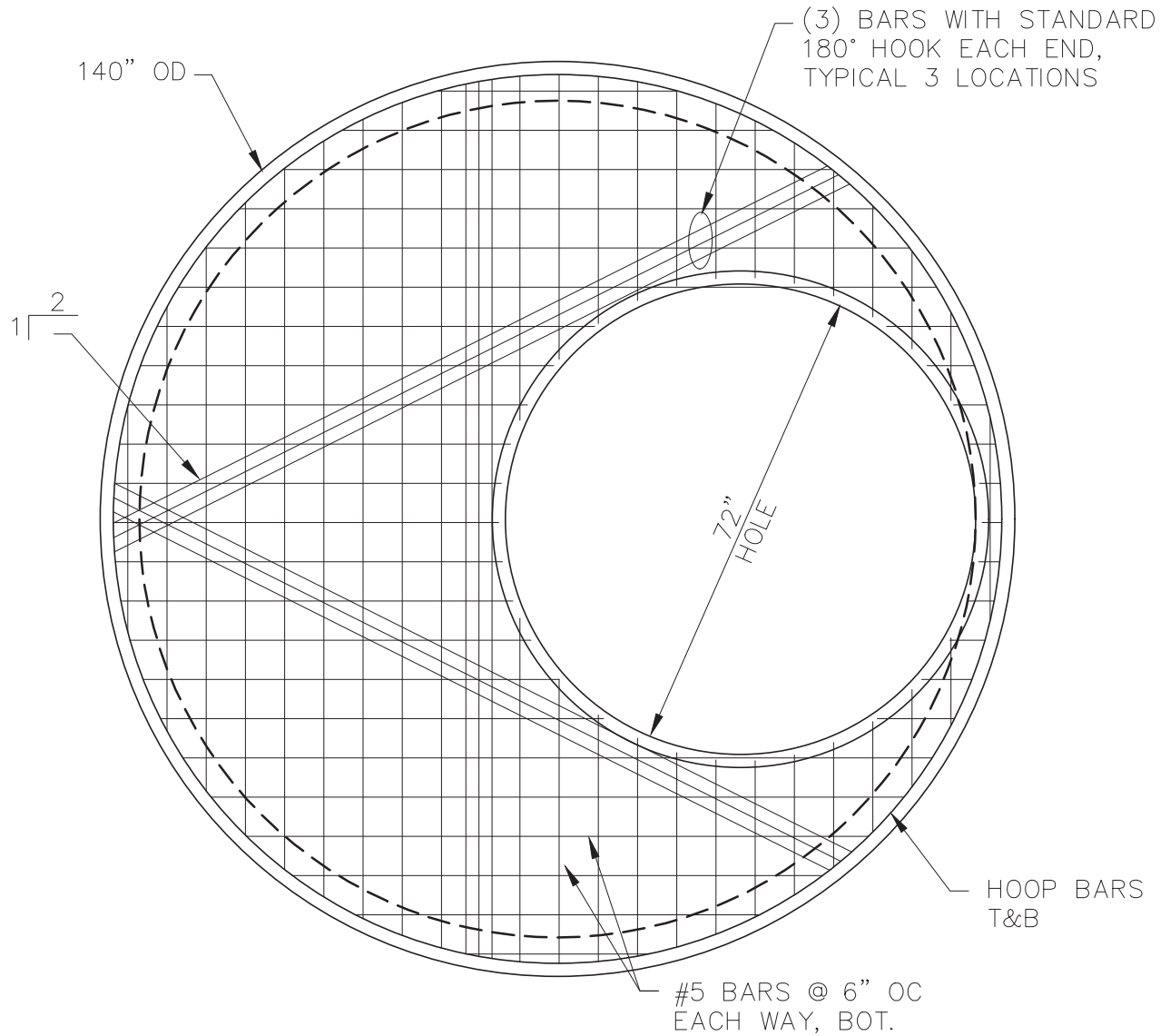

**PRECAST
 CONCRETE REDUCING SLAB
 (140" TO 72")**

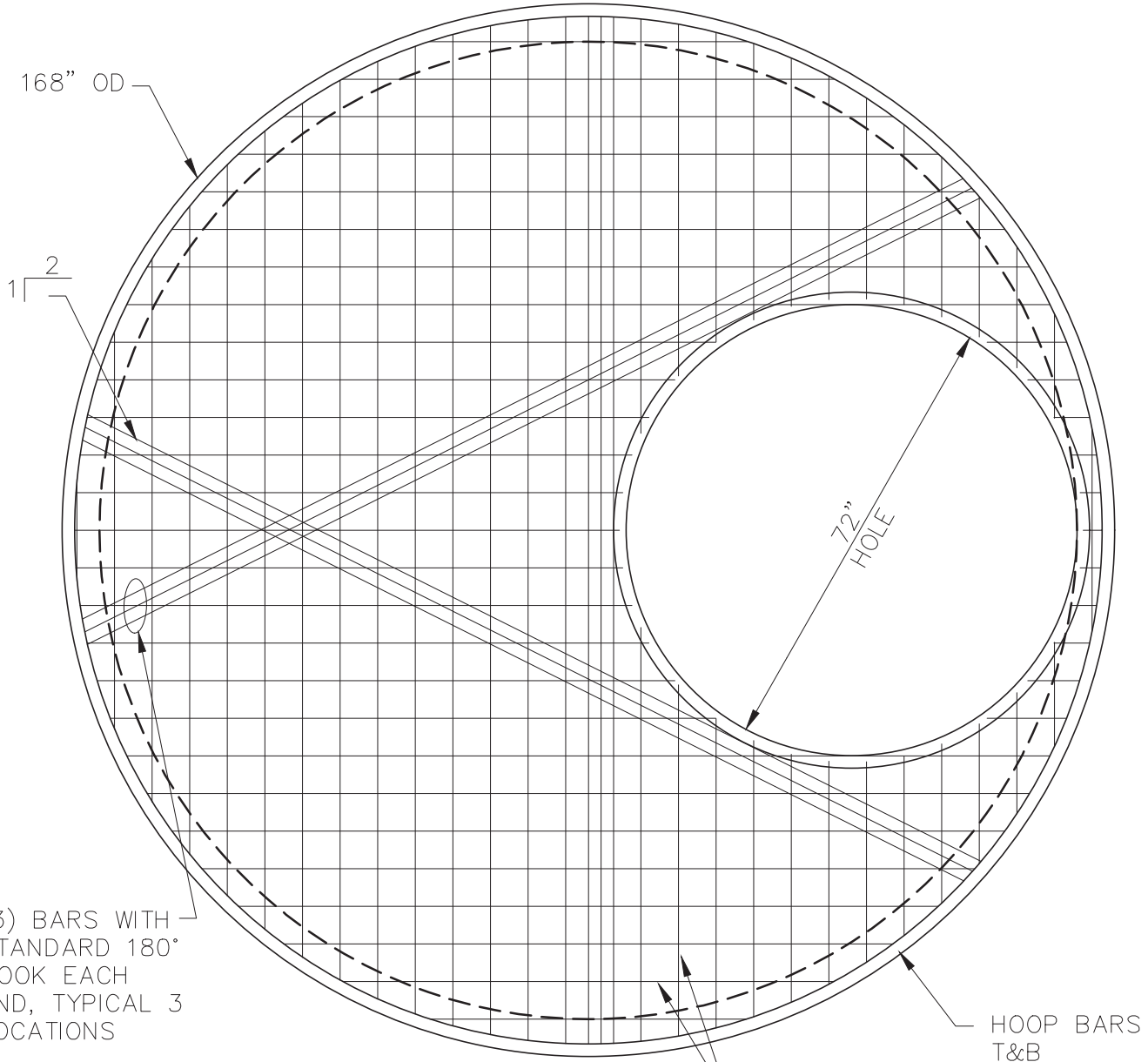

(3) BARS WITH STANDARD 180° HOOK EACH END, TYPICAL 3 LOCATIONS

#5 BARS @ 6" OC EACH WAY, BOT.

HOOP BARS T&B

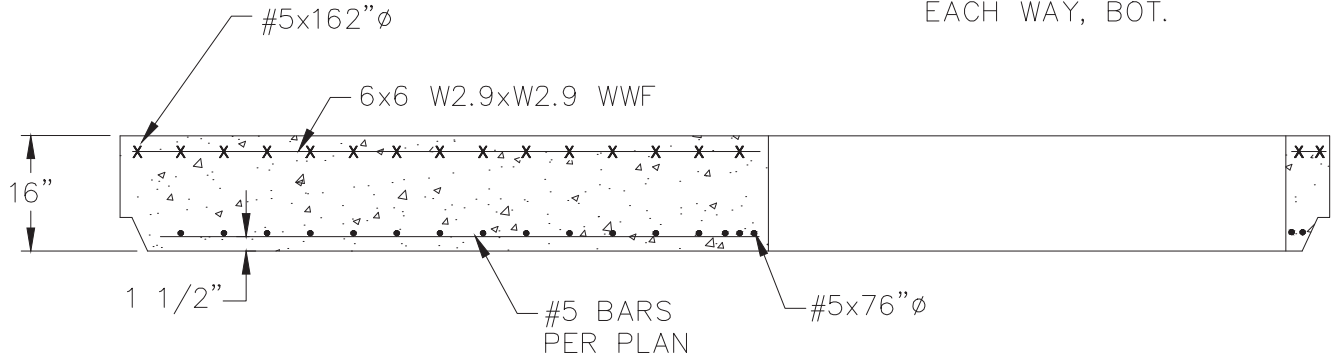

SCALE:
N.T.S.
APPROVED:
REVISED:
2/24

PRECAST CONCRETE REDUCING SLAB (168" TO 72")

SECTION #
55.05
DETAIL #
55-16

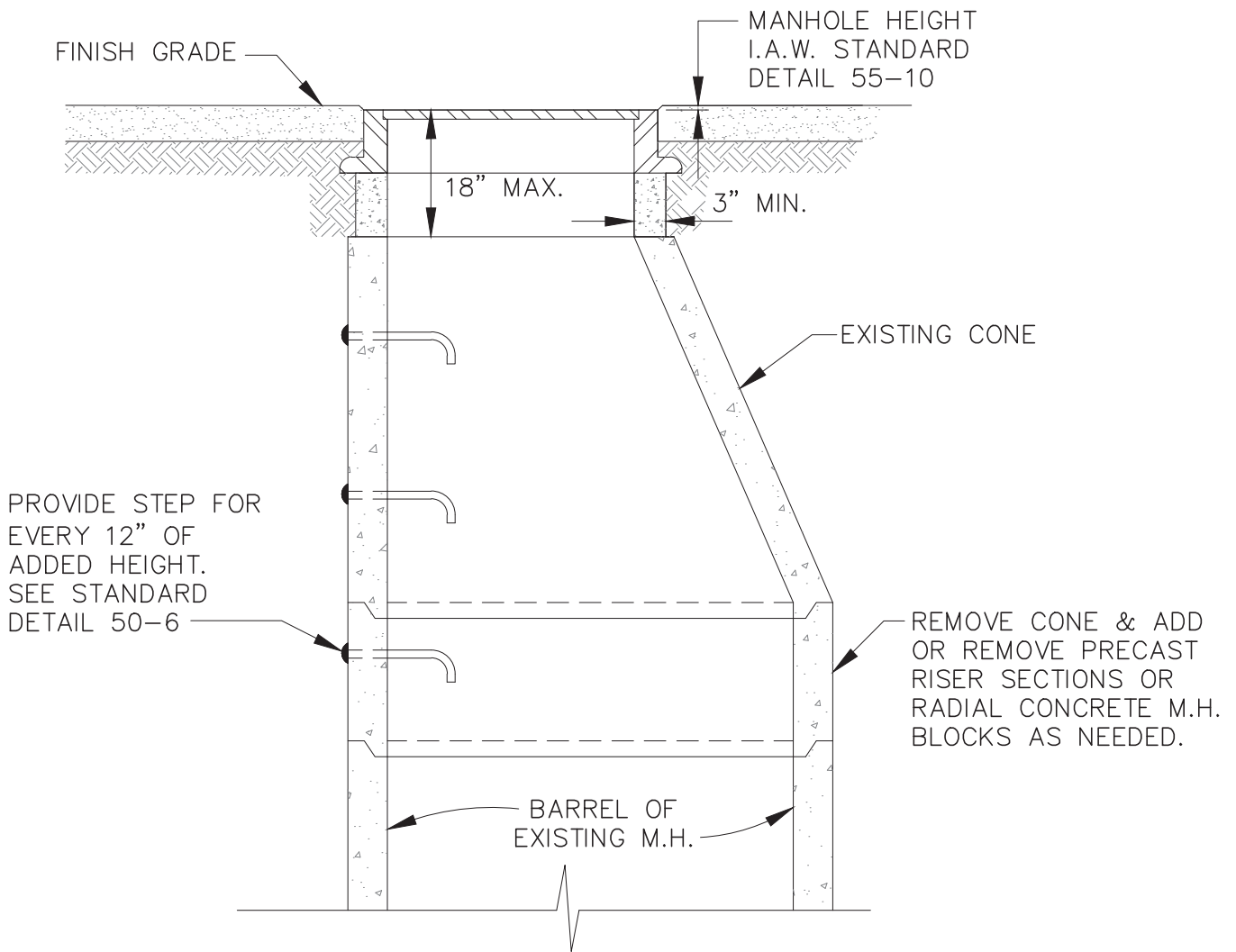

NOTE:

1. RESET CONCRETE GRADE RING IN BEDDING MATERIAL AS SPECIFIED IN SECTION 55.05, ARTICLE 5.2.B – REINFORCED CONCRETE MANHOLES.
2. REFER TO ASTM DESIGNATION C-478 FOR DESIGN AND STRENGTH REQUIREMENTS.
3. RESET CONE IN RAM-NEK OR EQUAL.

 <p>MUNICIPALITY OF ANCHORAGE</p>	<p>SCALE: N.T.S.</p> <p>APPROVED:</p> <p>REVISED: 2/24</p>	<p>MANHOLE CONE ADJUSTMENT</p>	<p>SECTION # 55.07</p> <p>DETAIL # 55-17</p>
--	--	---	--

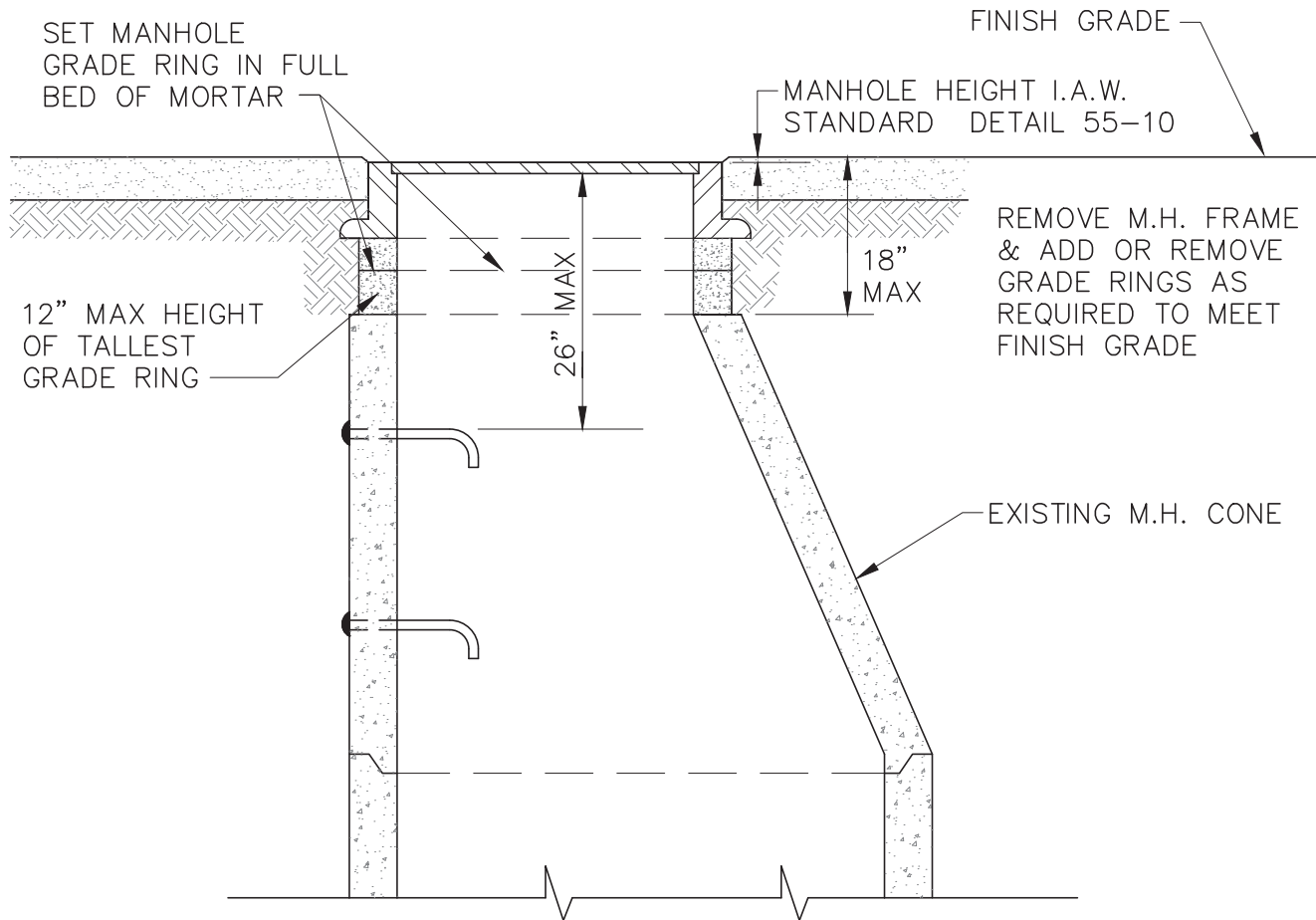

NOTE:

1. REFER TO ASTM DESIGNATION C-478 FOR DESIGN AND STRENGTH REQUIREMENTS.
2. WHEN AN ADJUSTMENT OF GREATER THAN 12" IN GRADE RINGS IS REQUIRED, ADJUST CONE I.A.W. STANDARD DETAIL 55-17 RATHER THAN GRADE RINGS.
3. IF NECESSARY, SHIM MANHOLE FRAME WITH STUD WASHERS, TO ADJUST FRAME TO THE DEPTH IN ACCORDANCE WITH STANDARD DETAIL 55-10. WHEN SHIMS ARE USED, SET MANHOLE FRAME IN A FULL BED OF MORTAR WITH SHIMS.

 <p>MUNICIPALITY OF ANCHORAGE</p>	<p>SCALE: N.T.S.</p> <p>APPROVED:</p> <p>REVISED: 2/24</p>	<h1>MANHOLE RING ADJUSTMENT</h1>	<p>SECTION # 55.07</p> <p>DETAIL # 55-18</p>
--	--	--------------------------------------	--

(2) 1" HANDLING HOLES ON A 30" DIA. BOLT CIRCLE

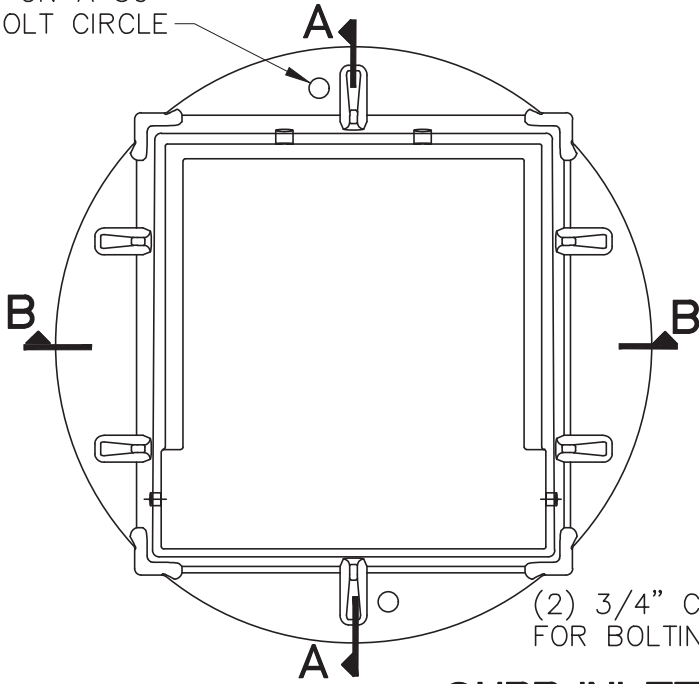

(2) 3/4" CORED HOLES FOR BOLTING TO T-BACK

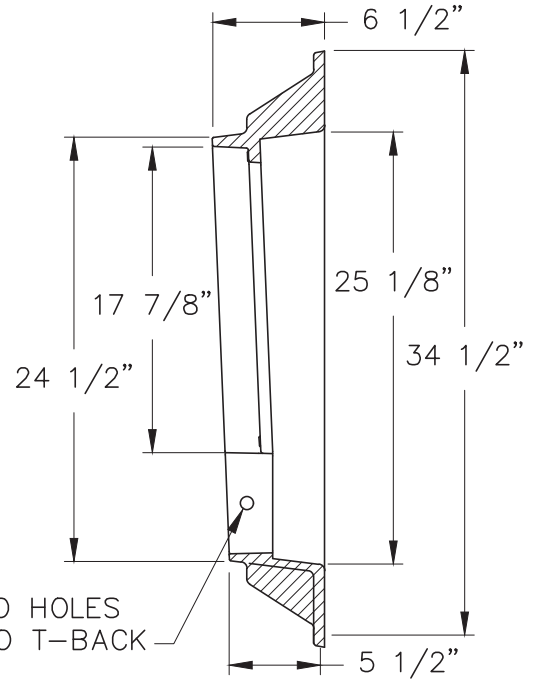

CURB INLET FRAME

SECTION AA

(2) 1" CORED WEEP HOLES

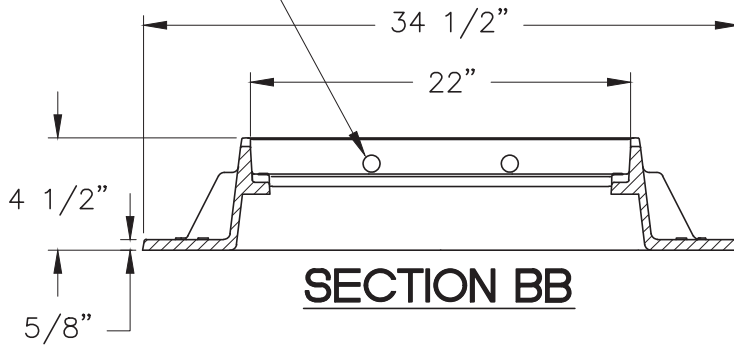

SECTION BB

3/4" RAISED LETTERS (RECESSED FLUSH)

RAISED FISH (RECESSED FLUSH)

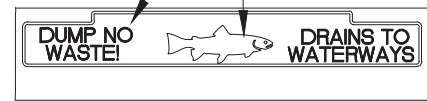

SECTION DD

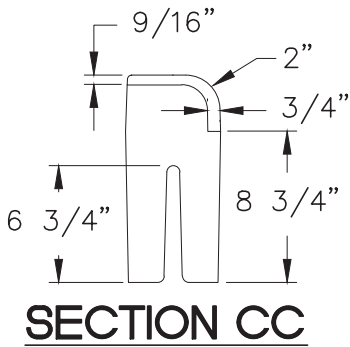

SECTION CC

CURB INLET HOOD

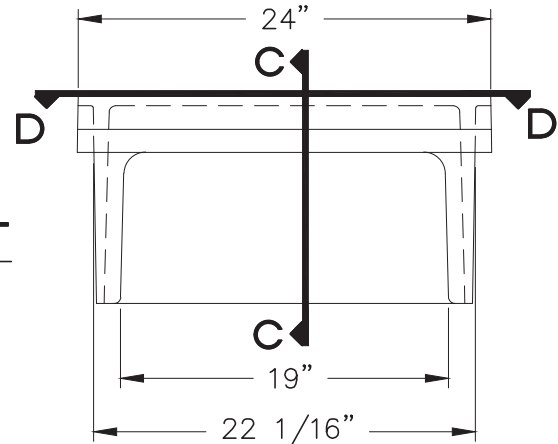

NOTE:

1. MINIMUM CASTING WEIGHT SHALL BE 400 LBS. FOR CURB INLET FRAME, HOOD & GRATE.
2. CURB INLET HOOD & GRATE SHALL CONFORM TO ASTM A536.



SCALE:
N.T.S.
APPROVED:
REVISED:
2/24

**CURB INLET
FRAME AND HOOD
FOR TYPE 1 CURB and GUTTER**

SECTION #
55.05&09
DETAIL #
55-19

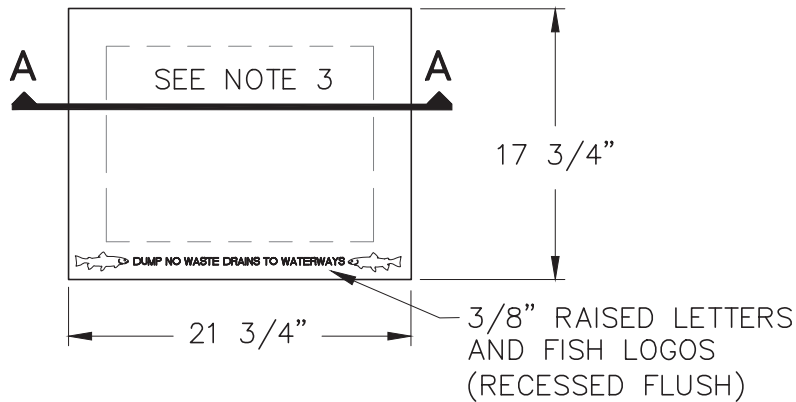

CURB INLET GRATE

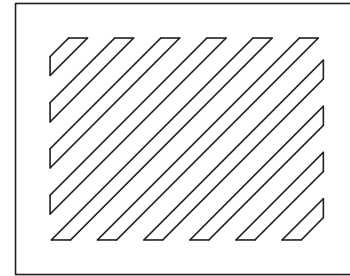

1" DIAGONAL BARS
WITH 1-1/2" OPENINGS

DIAGONAL GRATE

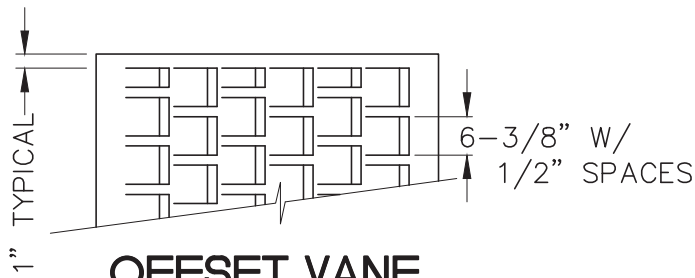

OFFSET VANE GRATE

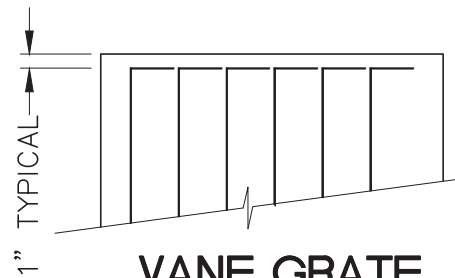

VANE GRATE

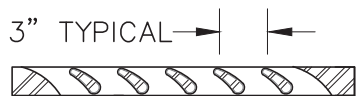

SECTION AA

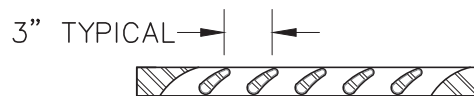

SECTION AA

NOTE:

1. MINIMUM CASTING WEIGHT SHALL BE 400 LBS. FOR CURB INLET FRAME, HOOD & GRATE.
2. CURB INLET HOOD & GRATE SHALL CONFORM TO ASTM A536.
3. GRATE SHALL BE AS SHOWN ON THE DRAWINGS OR SPECIFIED BY THE ENGINEER.

MUNICIPALITY



OF ANCHORAGE

SCALE:
N.T.S.

APPROVED:

REVISED:
2/24

**CURB INLET GRATES
FOR TYPE 1 CURB and GUTTER**

SECTION #
55.05&09

DETAIL #
55-20

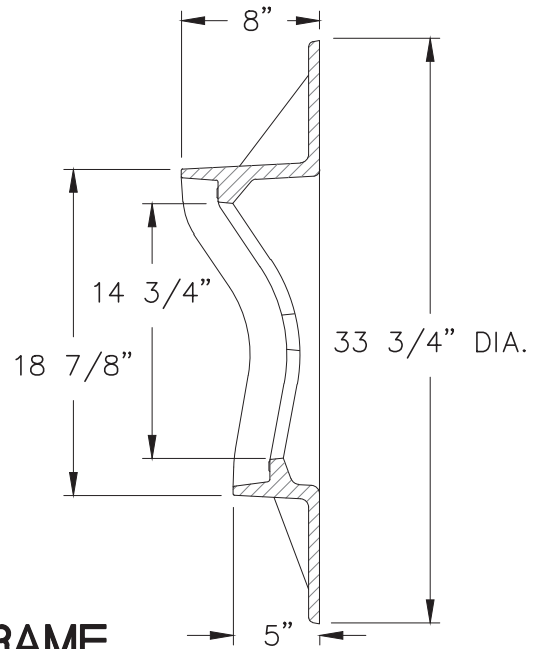
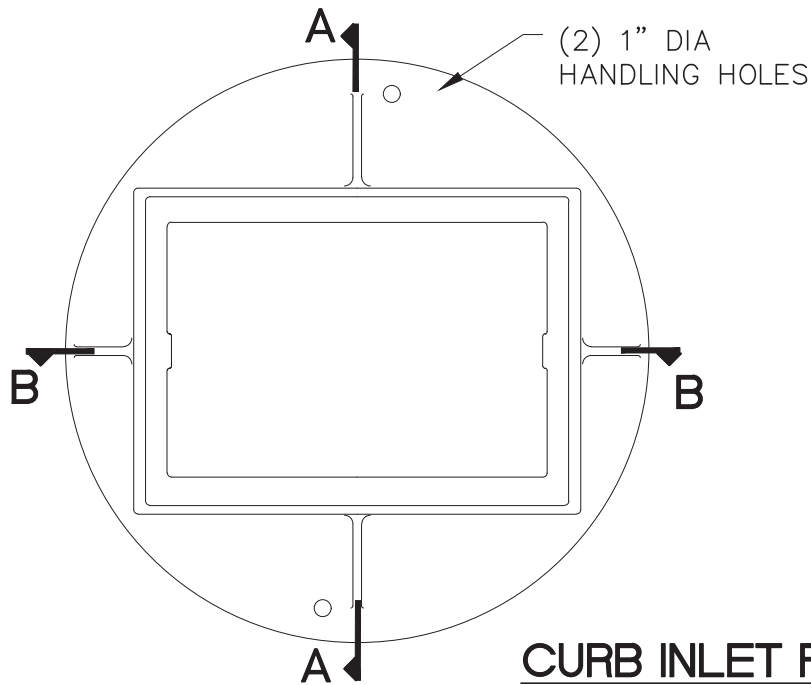

SECTION AA

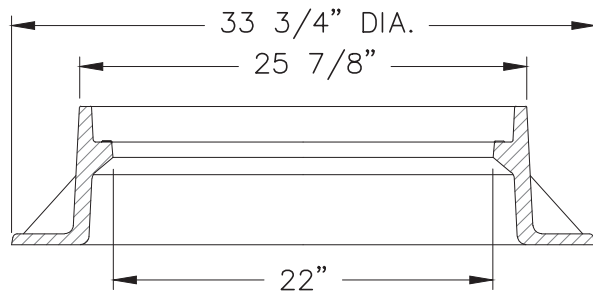

SECTION BB

NOTE:

1. MINIMUM CASTING WEIGHT SHALL BE 400 LBS. FOR CURB INLET FRAME & GRATE.
2. CURB INLET GRATE SHALL CONFORM TO ASTM A536.
3. GRATE SHALL BE AS SHOWN ON THE DRAWINGS OR SPECIFIED BY THE ENGINEER.

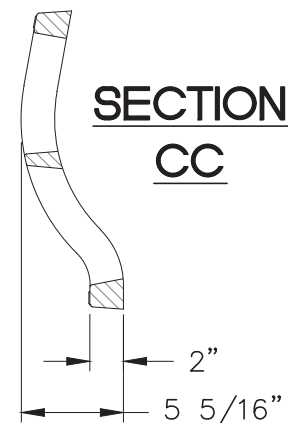
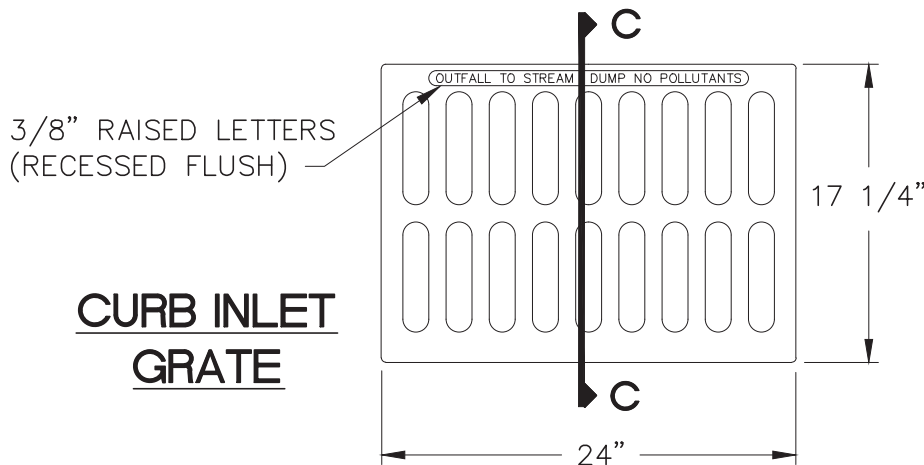

SCALE:
N.T.S.
APPROVED:
REVISED:
2/24

**CURB INLET
FOR TYPE 2 CURB and GUTTER**

SECTION #
55.09
DETAIL #
55-21

CATCH BASIN INLET

- FOR TYPE 1 CURB & GUTTER
SEE STANDARD DETAILS 55-19
AND 55-20
- FOR TYPE 2 CURB & GUTTER
SEE STANDARD DETAIL 55-21

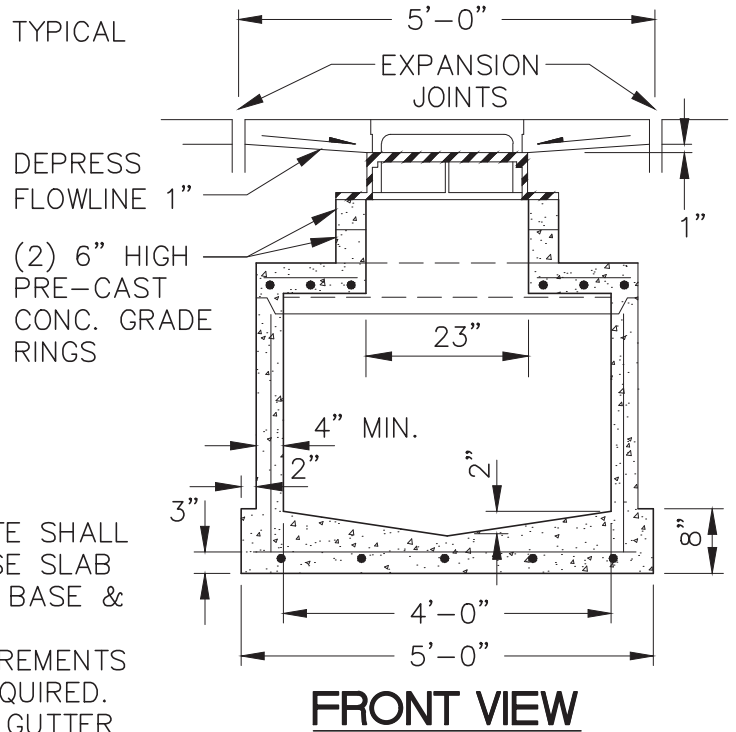
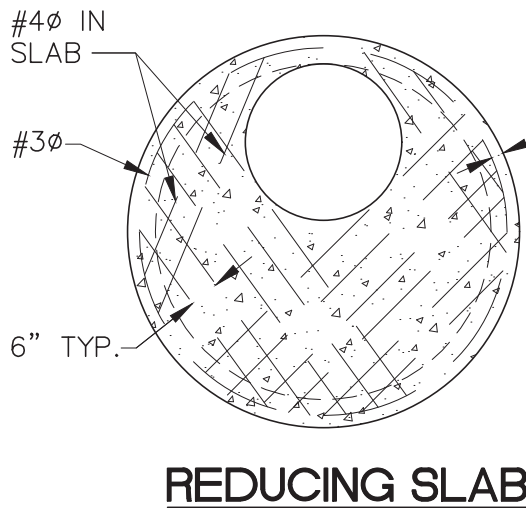
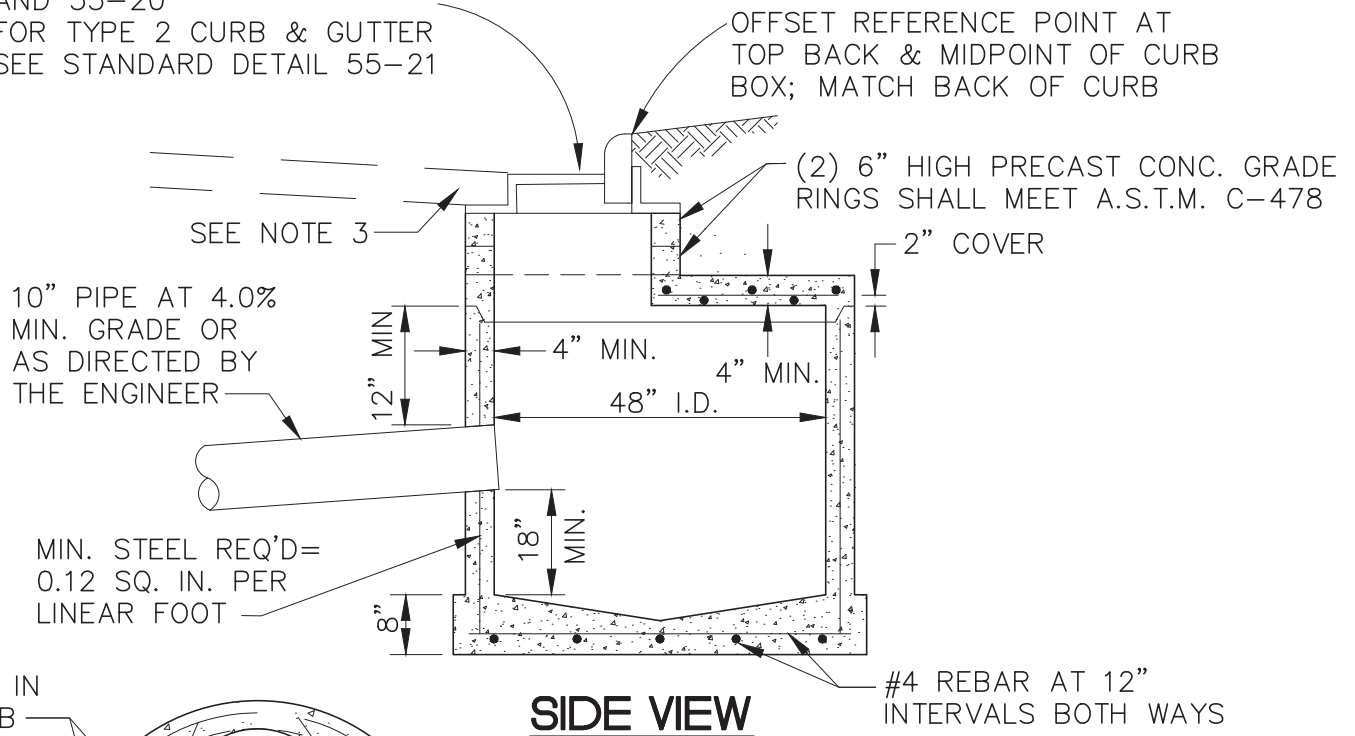

NOTE:

1. COMPRESSIVE STRENGTH OF CONCRETE SHALL BE MINIMUM 4000 P.S.I., EXCEPT BASE SLAB WHICH MAY BE 3000 P.S.I. CONNECT BASE & BARREL WITH CONTINUOUS STEEL.
2. SEE ASTM C-478 FOR DESIGN REQUIREMENTS AND MINIMUM REINFORCING STEEL REQUIRED.
3. AT CATCH BASIN, DELETE CONCRETE GUTTER PAN. FOR TYPE 1 CURB & GUTTER PAVE TO FACE OF CATCH BASIN INLET. FOR TYPE 2 CURB & GUTTER PROVIDE 5" CONCRETE GUTTER PAN BETWEEN CASTING AND EDGE OF ASPHALT.

 <p>MUNICIPALITY OF ANCHORAGE</p>	<p>SCALE: N.T.S.</p> <p>APPROVED:</p> <p>REVISED: 2/24</p>	<p>PRECAST CATCH BASIN</p>	<p>SECTION # 55.09</p> <p>DETAIL # 55-22</p>
--	--	-----------------------------------	--

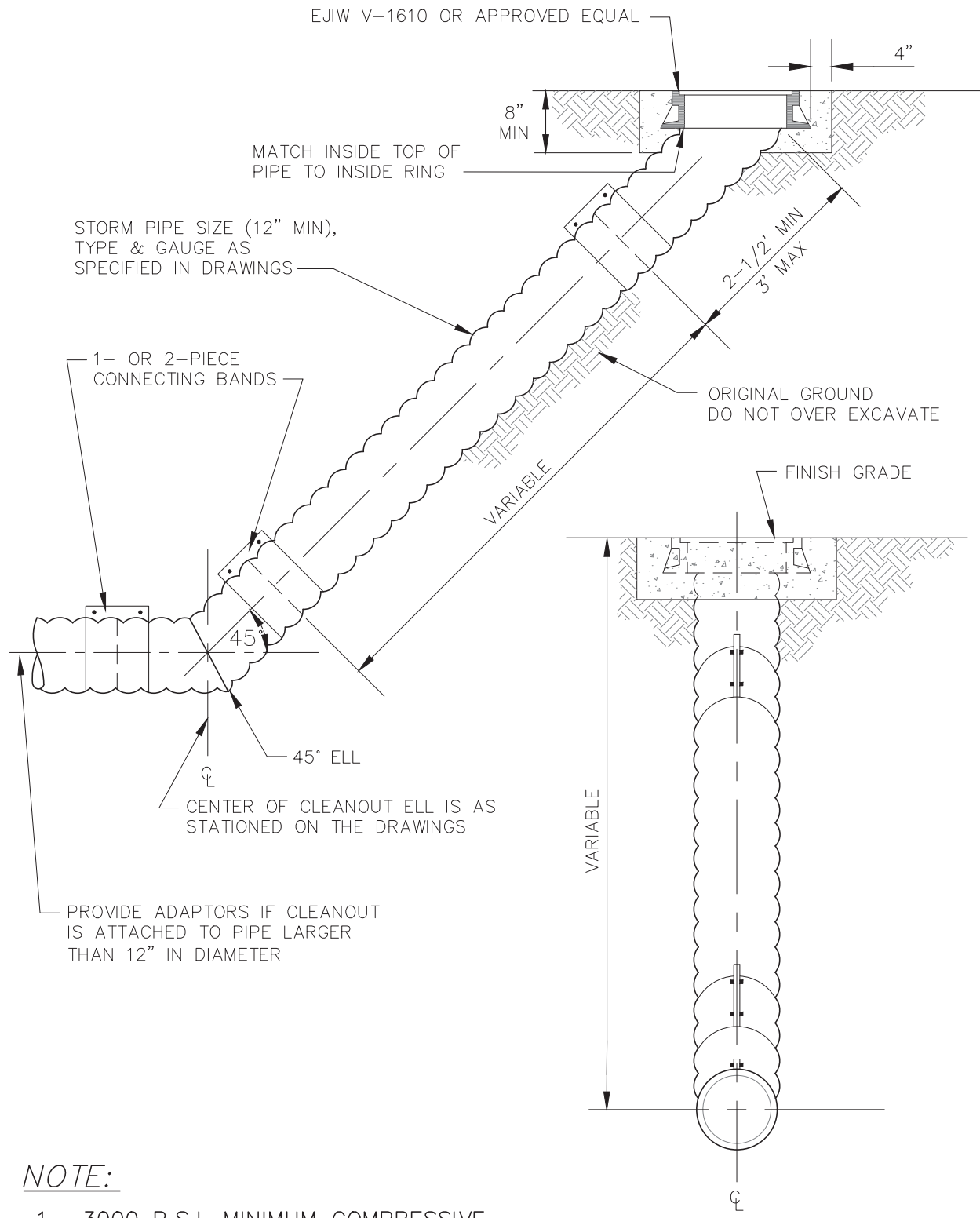

NOTE:

1. 3000 P.S.I. MINIMUM COMPRESSIVE STRENGTH CONCRETE.

 <p>MUNICIPALITY OF ANCHORAGE</p>	<p>SCALE: N.T.S.</p> <p>APPROVED:</p> <p>REVISED: 2/24</p>	<h1>STORM DRAIN CLEANOUT</h1>	<p>SECTION # 55.14</p> <p>DETAIL # 55-23</p>
--	--	-------------------------------	--

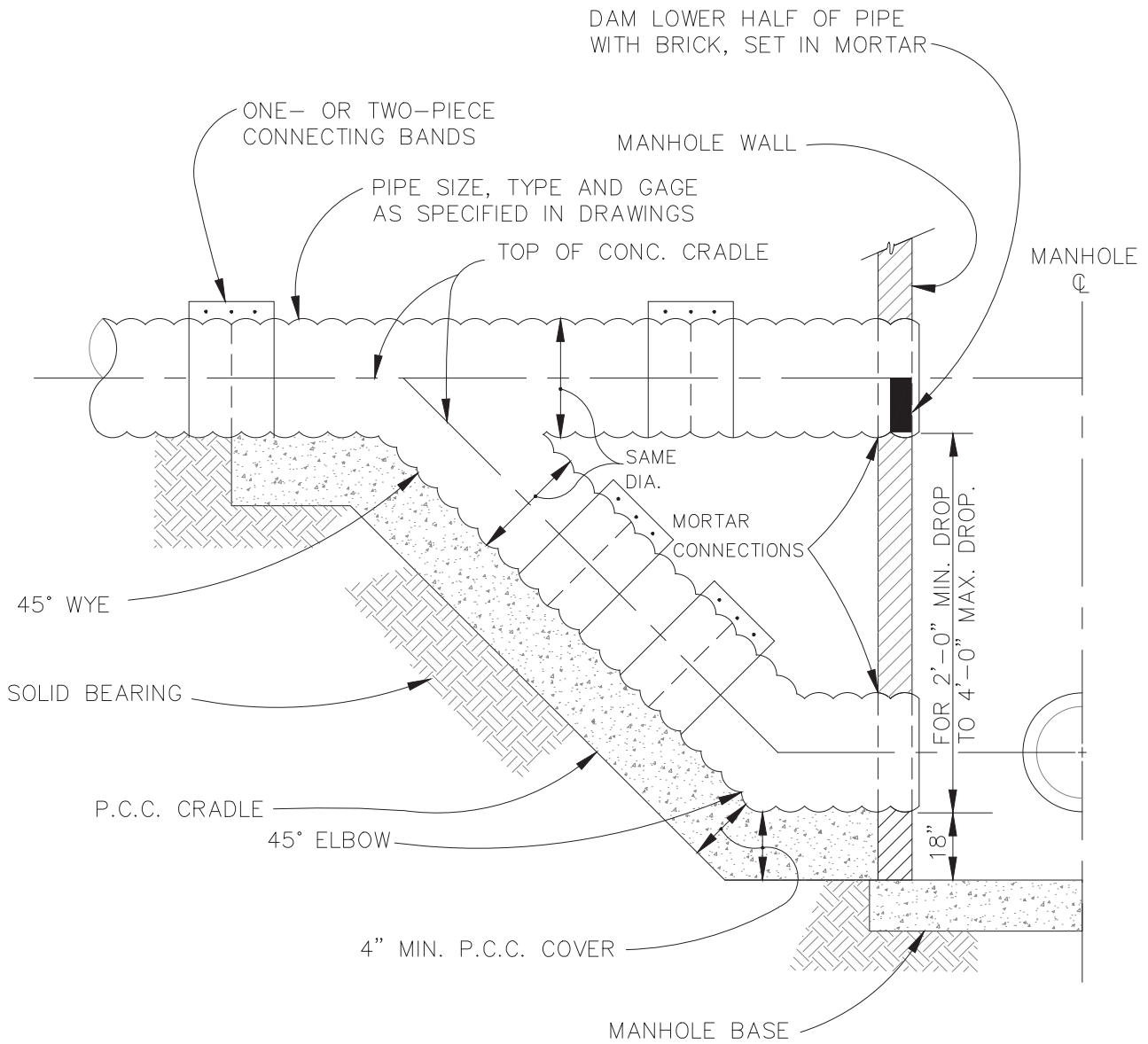

NOTE:

1. 3000 P.S.I. MIN. COMPRESSIVE STRENGTH CONCRETE FOR CRADLE.
2. PIPE SHALL PROTRUDE 2" INTO MANHOLE.



SCALE:
N.T.S.
APPROVED:
REVISED:
2/24

STORM DRAIN DROP CONNECTION (2' MIN. DROP)

SECTION #
55.16

DETAIL #
55-24

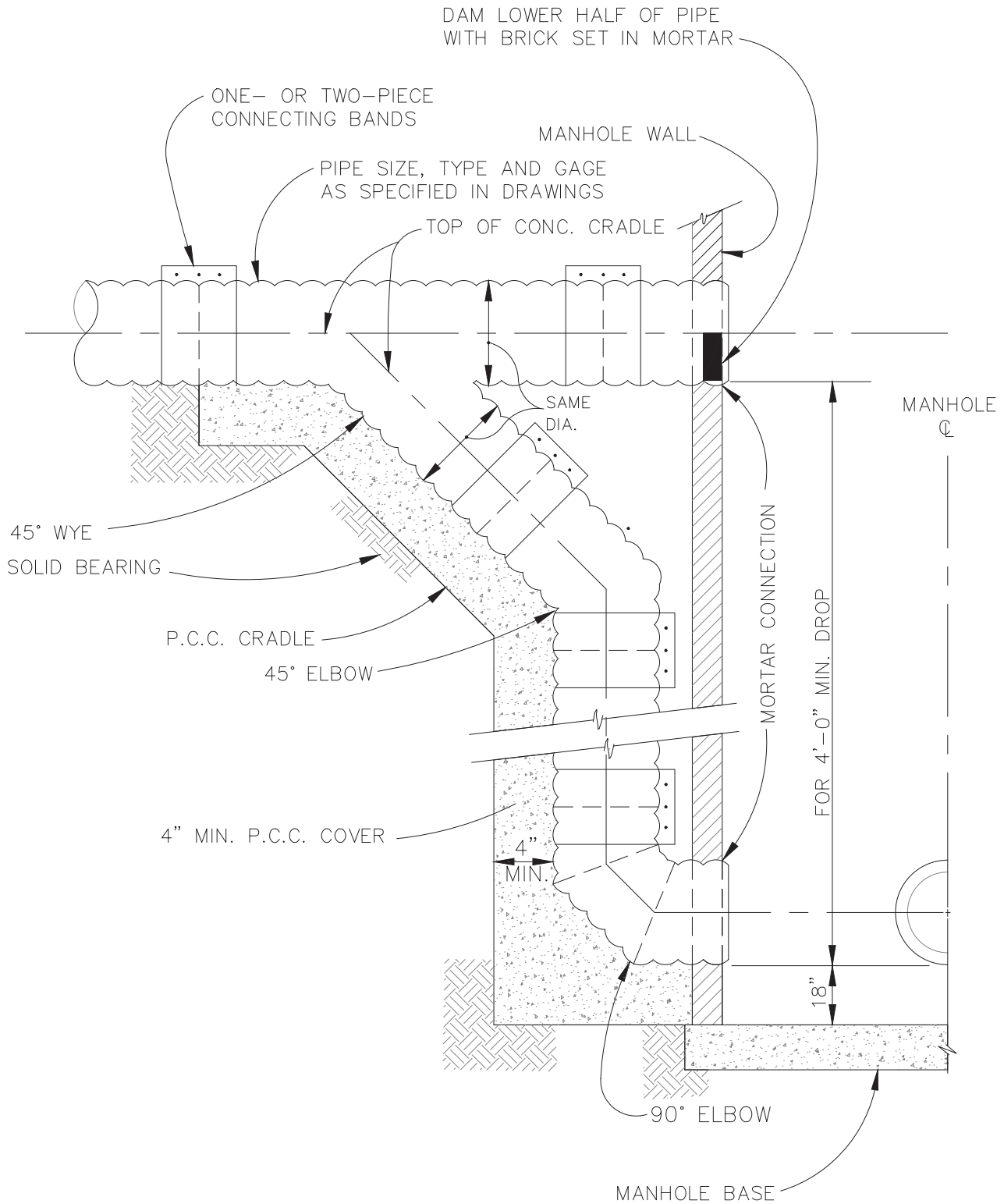

NOTE:

1. 3000 P.S.I. MIN. COMPRESSIVE STRENGTH CONCRETE FOR CRADLE
2. PIPE SHALL PROTRUDE 2" INTO MANHOLE.

STORM DRAIN DROP CONNECTION (4' MIN. DROP)

MUNICIPALITY



OF ANCHORAGE

SCALE:
N.T.S.

APPROVED:

REVISED:
2/24

SECTION #
55.16

DETAIL #
55-25

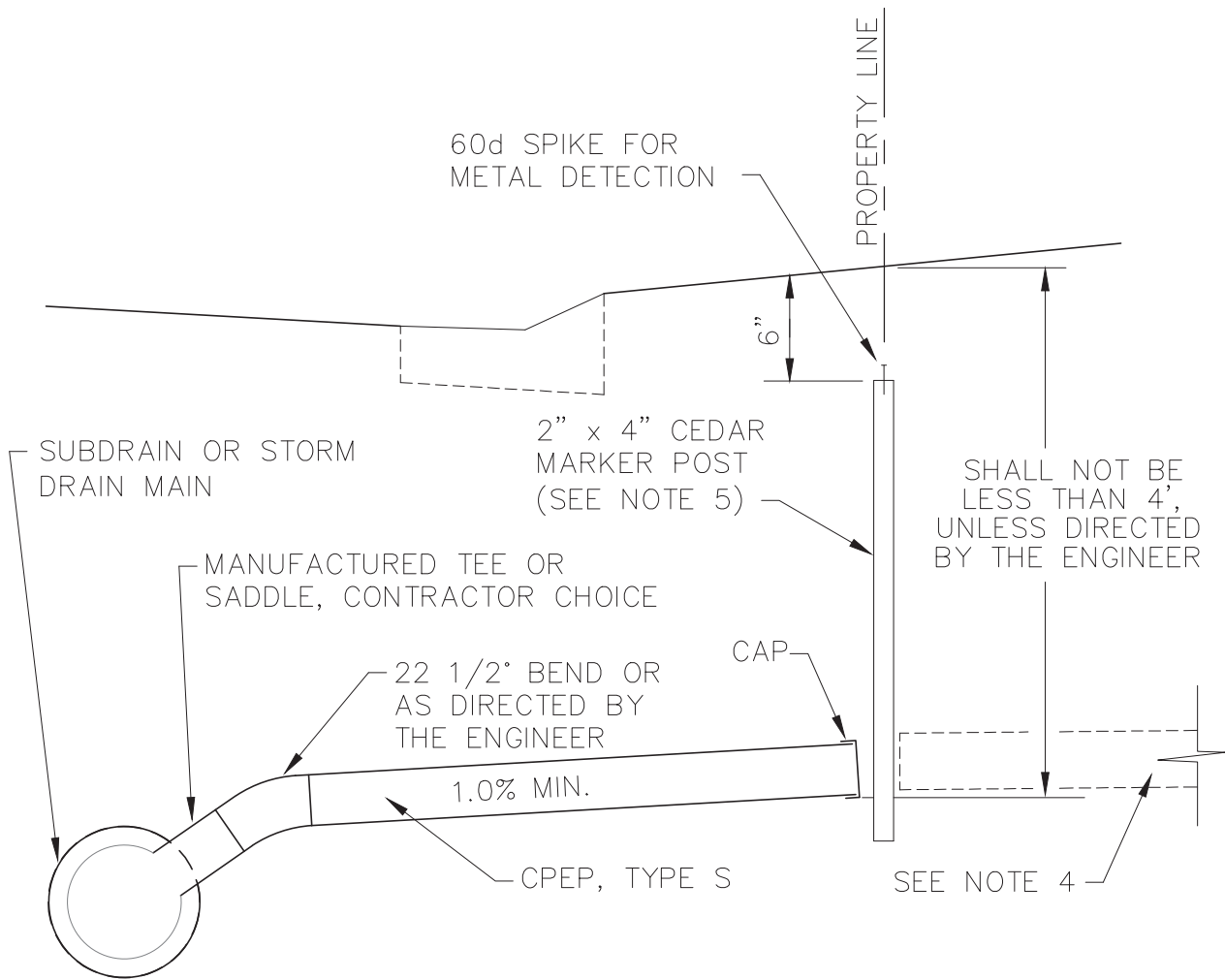

NOTE:

1. FINAL LOCATION OF THE FOOTING DRAIN SERVICE MAY BE ADJUSTED BY THE ENGINEER.
2. BACKFILL WITH TYPE II CLASSIFIED FILL AND BACKFILL WITHIN ROAD PRISM. BACKFILL WITH NATIVE MATERIAL BEHIND CURB.
3. WHEN FOOTING DRAIN CONNECTS DIRECTLY TO A MANHOLE, OMIT THE 22 1/2° BEND AND CONSTRUCT THE INVERT A MINIMUM OF 1' ABOVE THE DOWNSTREAM INVERT.
4. CONNECT TO ON-PROPERTY FOOTING DRAIN, WHEN PRESENT, AT PROPERTY LINE, AND OMIT MARKER POST. CONTRACTOR SHALL ADAPT AND PROVIDE BELL-REDUCER OR COUPLING CONNECTION TO EXISTING FOOTING DRAIN OF WHATEVER PIPE SIZE AND TYPE AND RESOLVE CONNECTION DETAILS WITH PROPERTY OWNER AND THE ENGINEER. CONNECTION TO EXISTING FOOTING DRAIN SHALL BE INCIDENTAL TO THIS PAY ITEM, AND NO ADDITIONAL PAYMENT SHALL BE MADE.
5. THE MARKER POST FOR A FOOTING DRAIN SERVICE TO AN UNDEVELOPED LOT SHALL EXTEND 3 FEET ABOVE GRADE. THE WORD "STORM" SHALL BE STENCILED ON THE SECTION OF POST PROTRUDING FROM THE GROUND.

MUNICIPALITY



OF ANCHORAGE

SCALE:
N.T.S.

APPROVED:

REVISED:
2/24

FOOTING DRAIN SERVICE

SECTION #
55.18

DETAIL #
55-26

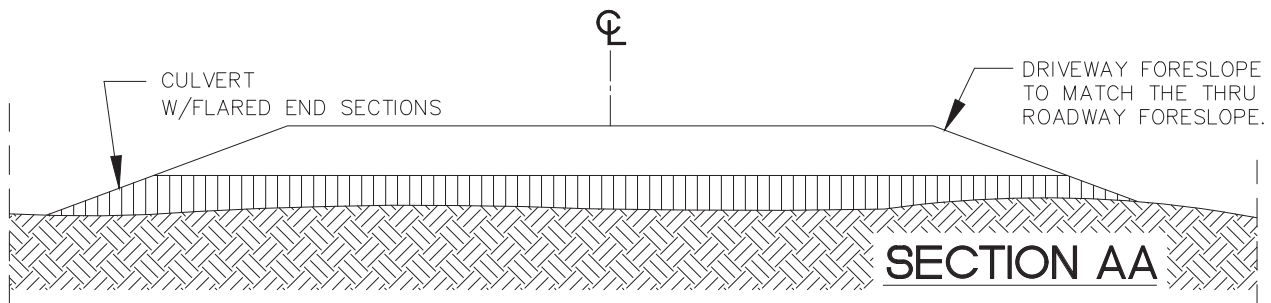
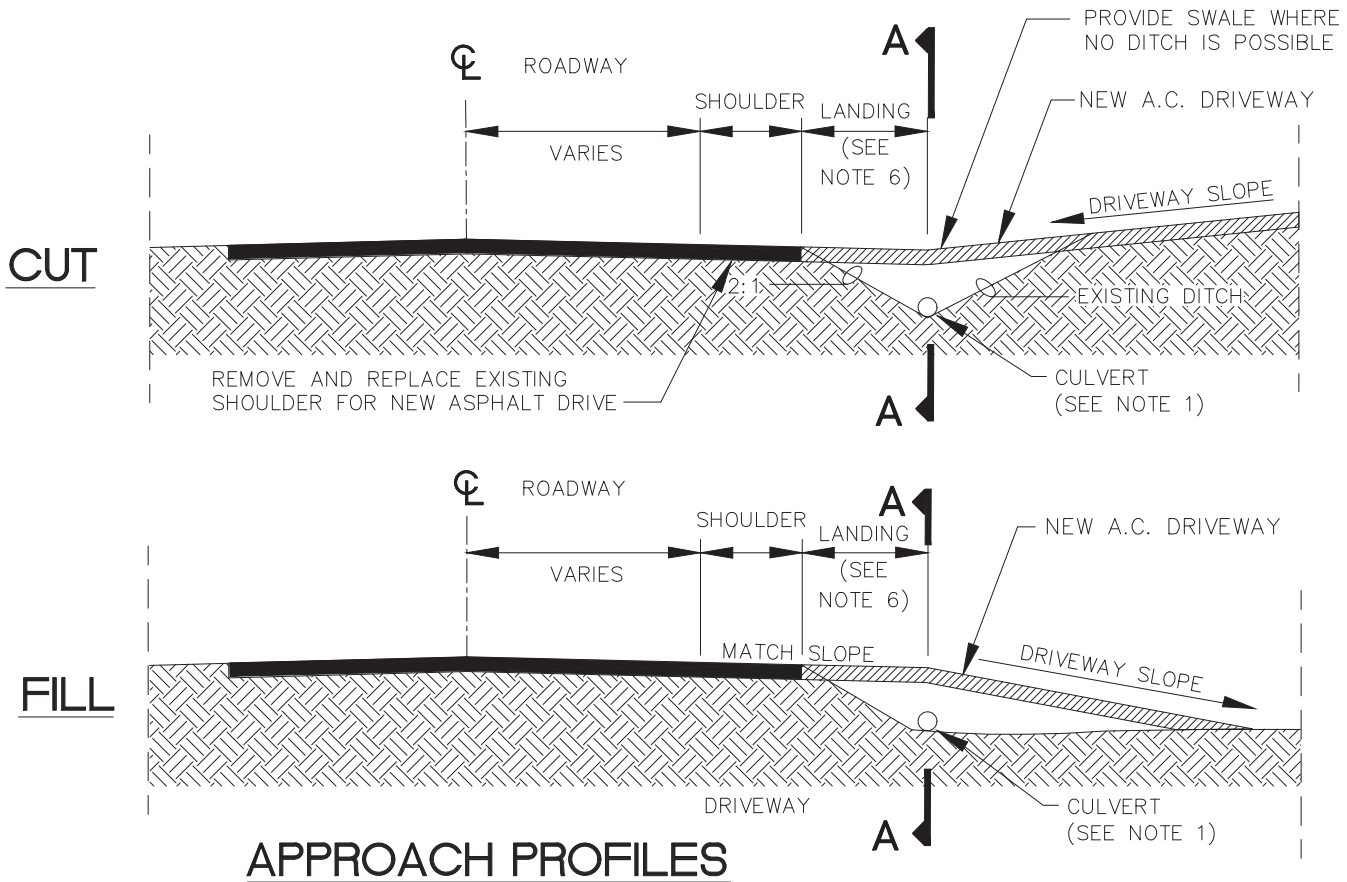

NOTE:

1. CULVERT DIAMETER IS MINIMUM 18" OR AS SPECIFIED IN THE DRAWINGS.
2. CULVERT INVERTS SHALL MATCH BOTTOM OF DITCH PROFILE. CONTRACTOR SHALL GRADE DITCH ON BOTH ENDS OF CULVERT PRIOR TO INSTALLATION TO ENSURE POSITIVE DRAINAGE.
3. DRIVEWAY CULVERTS SHALL HAVE A MINIMUM 12" COVER FROM BOTTOM OF A.C. PAVEMENT TO TOP OF PIPE.
4. CULVERT SHALL BE BEDDED IN MINIMUM 6" CLASS "C" BEDDING MATERIAL. BACKFILL SHALL BE TYPE II-A CLASSIFIED FILL & BACKFILL COMPACTED TO 95% OF MAXIMUM DENSITY. BACKFILL AND BEDDING ARE INCIDENTAL TO COST OF CULVERT INSTALLATION.
5. CULVERT END SECTIONS SHALL BE FLARED AND ARE INCIDENTAL TO CULVERT INSTALLATION.
6. LANDING AREA MAXIMUM SLOPE $\pm 2\%$. RESIDENTIAL DRIVEWAY, 12' MINIMUM. COMMERCIAL/INDUSTRIAL DRIVEWAY, 20' MINIMUM.

MUNICIPALITY



OF ANCHORAGE

SCALE:
N.T.S.

APPROVED:

REVISED:
2/24

DRIVEWAY CULVERT DETAILS

SECTION #
55.21

DETAIL #
55-27

CATCH BASIN INLET

- FOR TYPE 1 CURB & GUTTER SEE STANDARD DETAILS 55-19 AND 55-20
- FOR TYPE 2 CURB & GUTTER SEE STANDARD DETAIL 55-21

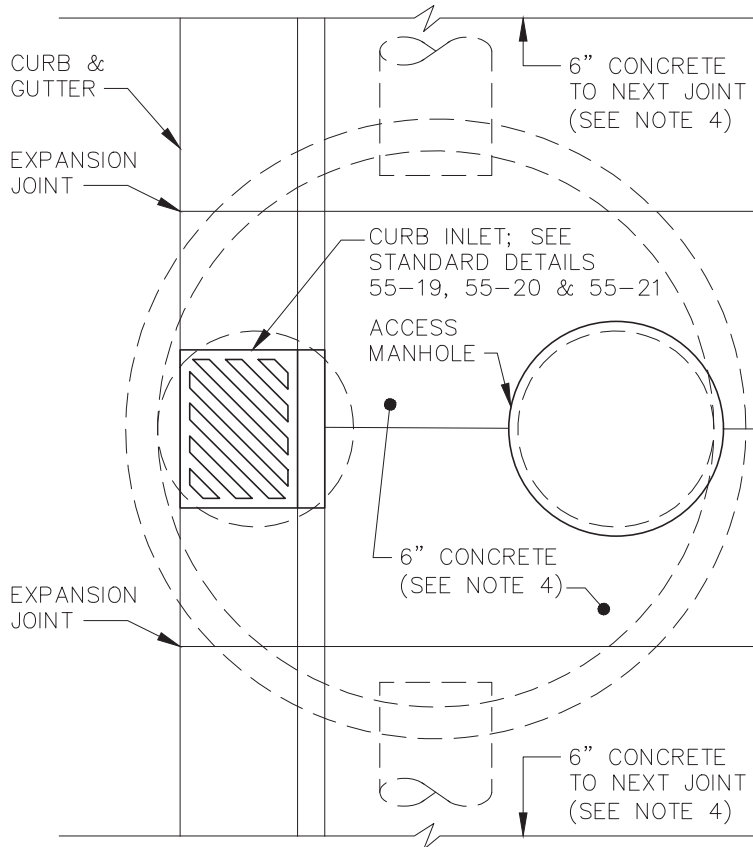
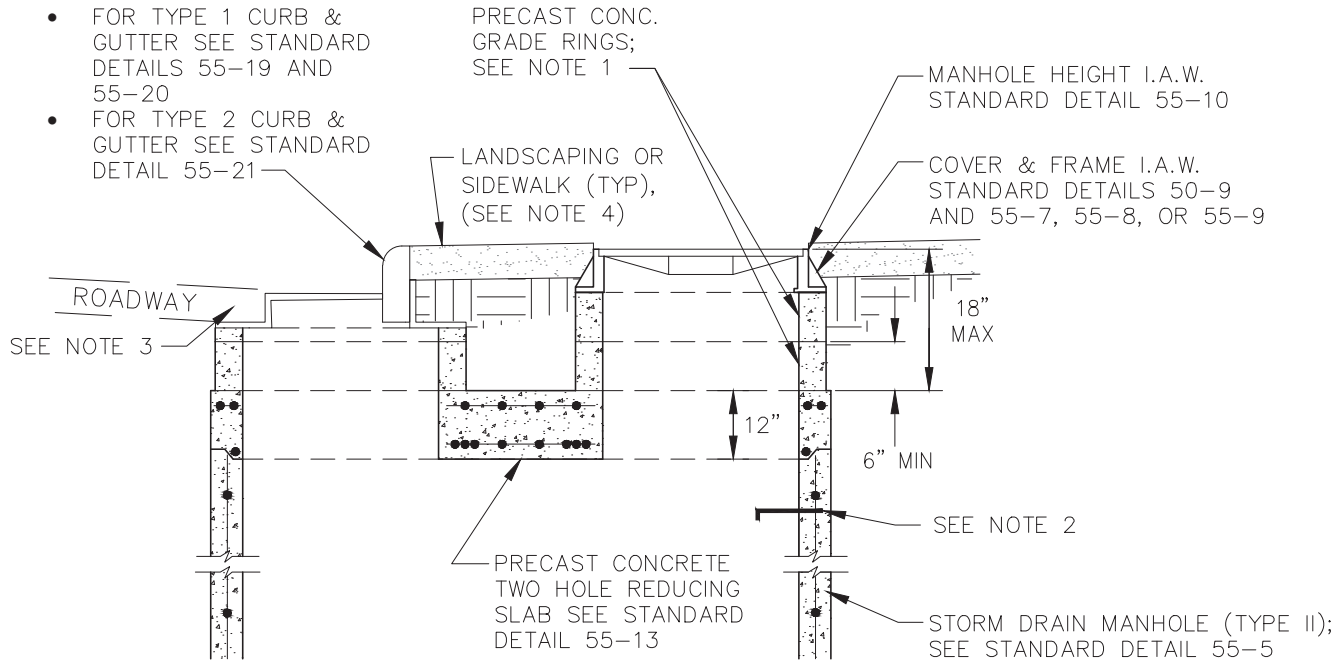

NOTE:

1. MANHOLE SHALL HAVE MINIMUM OF ONE 6" GRADE RING. A 3" GRADE RING UNDER THE CATCH BASIN IS SUFFICIENT FOR THE TWO-HOLE CONFIGURATION.
2. CONTRACTOR SHALL ALIGN THE MANHOLE SO THAT THE LADDER RUNGS ARE IN LINE WITH THE MANHOLE ACCESS LID. THE MAXIMUM DISTANCE TO FIRST LADDER RUNG IS 34".
3. AT CATCH BASIN, DELETE CONCRETE GUTTER PAN. FOR TYPE 1 CURB & GUTTER PAVE TO FACE OF CATCH BASIN INLET. FOR TYPE 2 CURB & GUTTER PROVIDE 5" CONCRETE GUTTER PAN BETWEEN CASTING AND EDGE OF ASPHALT.
4. WHEN ACCESS MANHOLE IS LOCATED IN A CONCRETE SIDEWALK, INCREASE CONCRETE THICKNESS TO 6-INCHES.

MUNICIPALITY



OF ANCHORAGE

SCALE:
N.T.S.

APPROVED:

REVISED:
2/24

DUAL ENTRY MANHOLE

SECTION #
55.05

DETAIL #
55-28

BYPASS MANHOLE
(TYPE II); SEE
STANDARD DETAIL 55-5.

SEE STANDARD
DETAIL 55-29B

LADDER RUNGS (TYP)

INLET PIPE

A

A

PLACE MANHOLE OPENINGS
OVER GATE HANDWHEEL
AND OVER LADDER RUNGS

WATERMAN CL-10
CANAL GATE OR
APPROVED EQUAL

10" CPEP
BYPASS PIPE

OIL AND GRIT
SEPARATOR;
STORMCEPTOR OR
APPROVED EQUAL

OUTLET PIPE

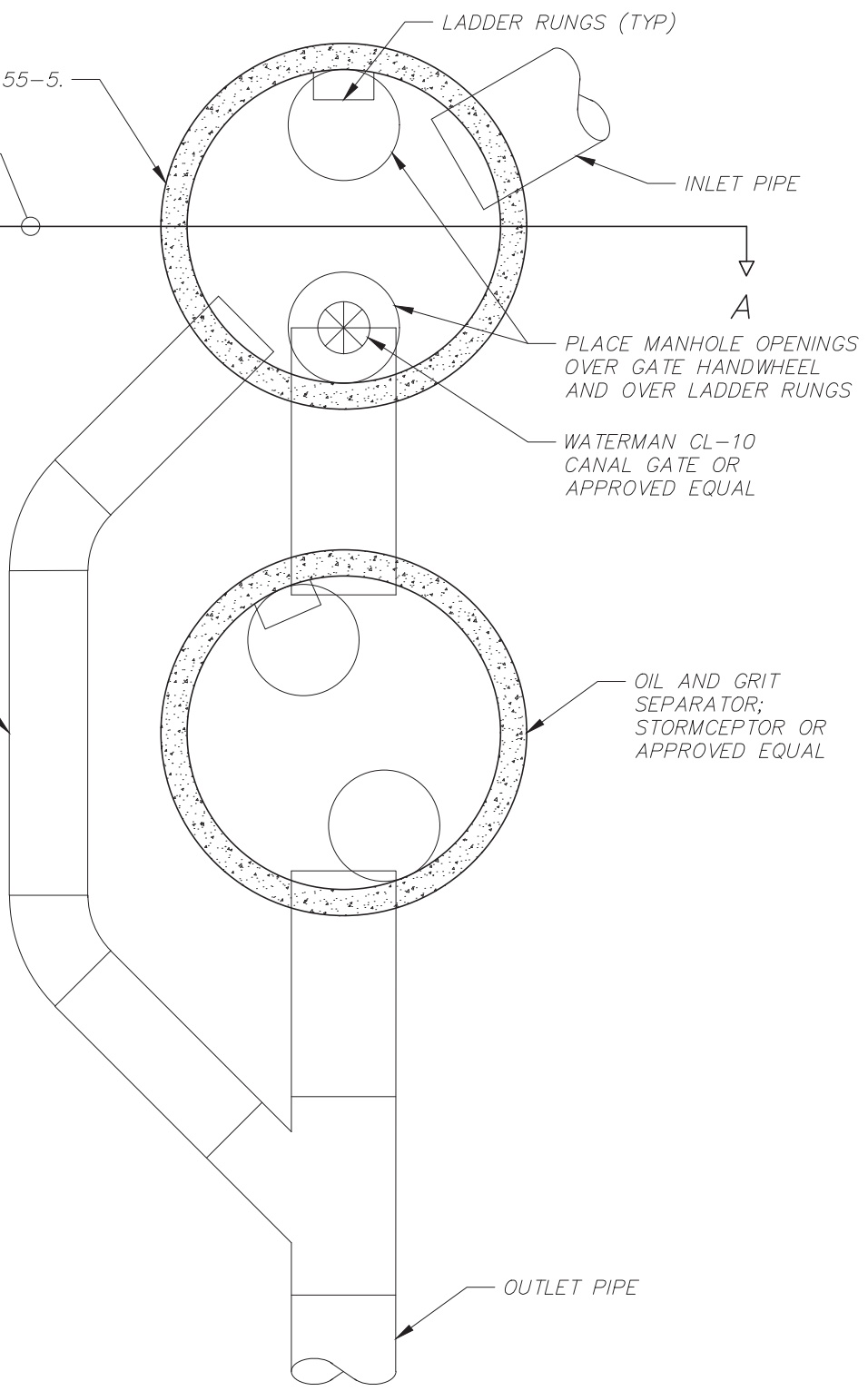

MUNICIPALITY



OF ANCHORAGE

SCALE:
N.T.S.

APPROVED:

REVISED:
2/24

OIL AND GRIT SEPARATOR BYPASS

SECTION #
55.22

DETAIL #
55-29A

MANHOLE HEIGHT I.A.W.
STANDARD DETAIL 55-10

COVER & FRAME I.A.W.
STANDARD DETAILS
50-9 & 55-7

EXTEND NO-RISE HANDWHEEL
12-INCHES (MAX) FROM TOP
OF CASTING

10" CPEP
BYPASS PIPE

CONC. GRADE
RINGS (TYP)

PRECAST CONCRETE TWO
HOLE REDUCING SLAB SEE
STANDARD DETAIL 55-13

OUTLET PIPE

WATERMAN CL-10
CANAL GATE OR
APPROVED EQUAL,
MOUNTED ON
OUTLET PIPE

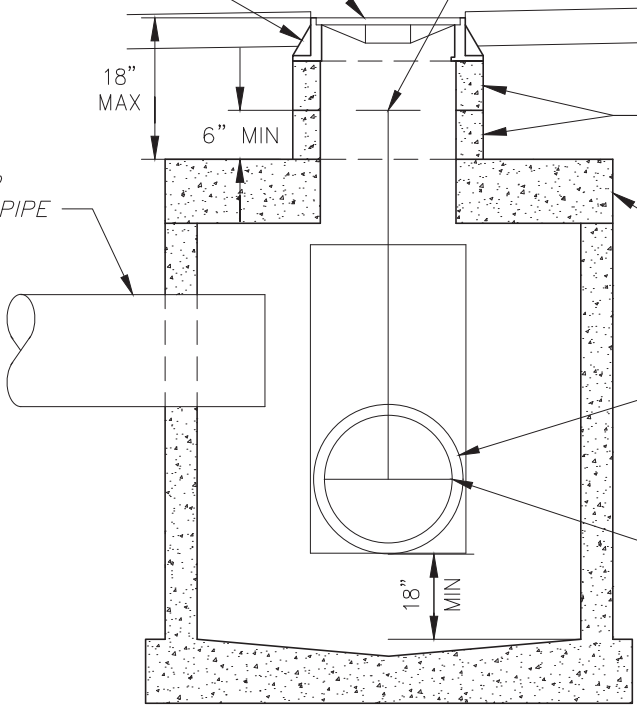

SECTION A-A

MUNICIPALITY



OF ANCHORAGE

SCALE:
N.T.S.

APPROVED:

REVISED:
2/24

OIL AND GRIT SEPARATOR BYPASS MANHOLE

SECTION #
55.22

DETAIL #
55-29B