



Municipality of Anchorage



Handout M.02

Garage Appliance Protection

Code Requirements

The 2003 International Mechanical Code (Section 303.4), the 2003 International Fuel Gas Code (Section 303.4), and the 2003 Uniform Plumbing Code (Section 508.14 (2)) all require that equipment/water heaters be protected from damage. The 2003 IMC, and 2003 IFGC state: "Equipment shall not be installed in a location where it is subject to mechanical damage unless it is protected by approved barriers." The 2003 UPC states: "Such equipment shall be located or protected so it is not subject to physical damage by a moving vehicle." The question posed is, what is substantial and adequate? Since people come to different conclusions on what might be considered substantial and adequate, these minimum requirements have been set forth.

Physical Requirements

1. An equipment platform installed in a garage or within a room accessed from the garage shall be a minimum of 18" in height under all conditions.
2. If the equipment platform is a minimum 24" high and the equipment does not extend beyond the face of the platform, additional barriers are not required.
3. If equipment is installed in an alcove, a barrier will not be required as long as the equipment does not protrude beyond the face of the wall and the height of the alcove platform, measured from the floor to the top of the platform, is a minimum of 24" in height.
4. If the equipment platform is less than 24" high, one or more barriers must be installed.
5. The barriers must be a minimum 30" high and be constructed of a minimum 2" diameter schedule 40 iron pipe.
6. The barrier must have a minimum 6" setback from the platform or equipment. The maximum unprotected distance shall not exceed five (5) feet.
7. The barrier must be installed per one of the following methods:
 - a. Buried a minimum of 2'-0" deep in compacted soil and imbedded in concrete slab.
 - b. Set in a minimum 1'-0" X 1'-0" square X 1'-0" deep block of concrete (slab included).
 - c. Secured to the wood framed garage floor with flange and stainless steel bolts and imbedded in concrete slab.
 - d. Secured to the concrete slab using a floor flange with a minimum of 4 3/8" diameter X 3-1/2" long galvanized or stainless anchor bolts.
8. Piping is not allowed to be surface mounted on the face of the platform, where it may be subjected to damage.
9. Unit heaters and related piping shall be mounted clear of any potential vehicle interference.
10. Physical clear width and depth of the garage must be maintained per Title 21. (See Figure 3)

Ron Thompson, Building Official
Effective date: May 15, 2006
(Ref. 01-05; 04-06)

PLATFORM REQUIREMENT

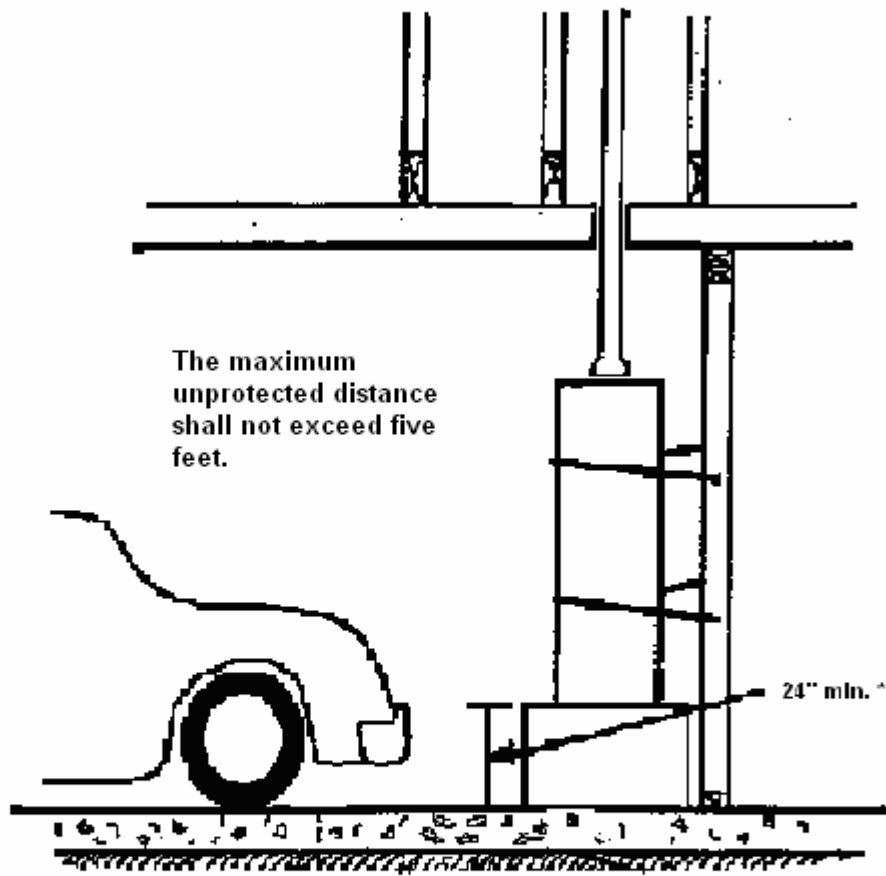

*If garage door openings are over 8' high, the minimum requirement is 30".

Protection of Appliances

Figure 1

POST LOCATION

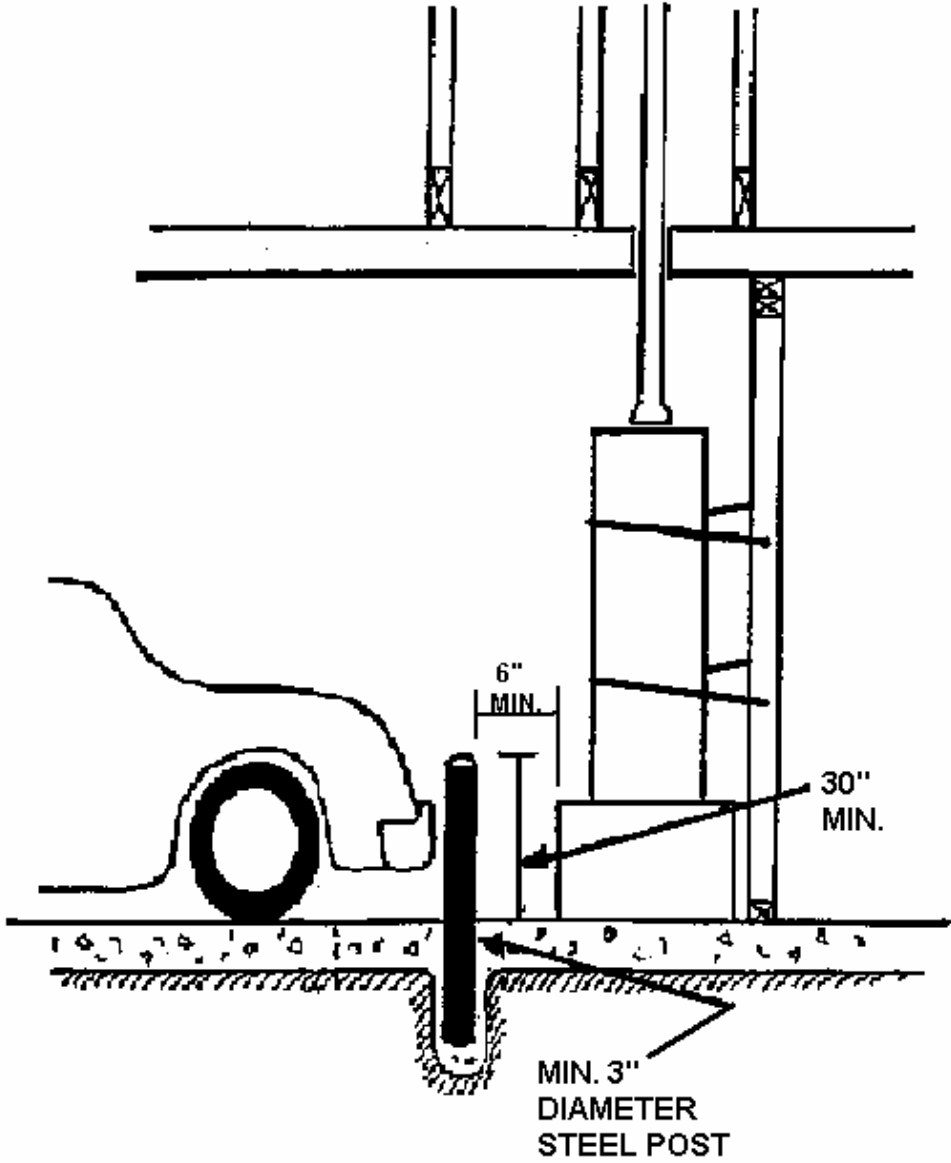

PROTECTION OF APPLIANCES

FIGURE 2

EXAMPLES

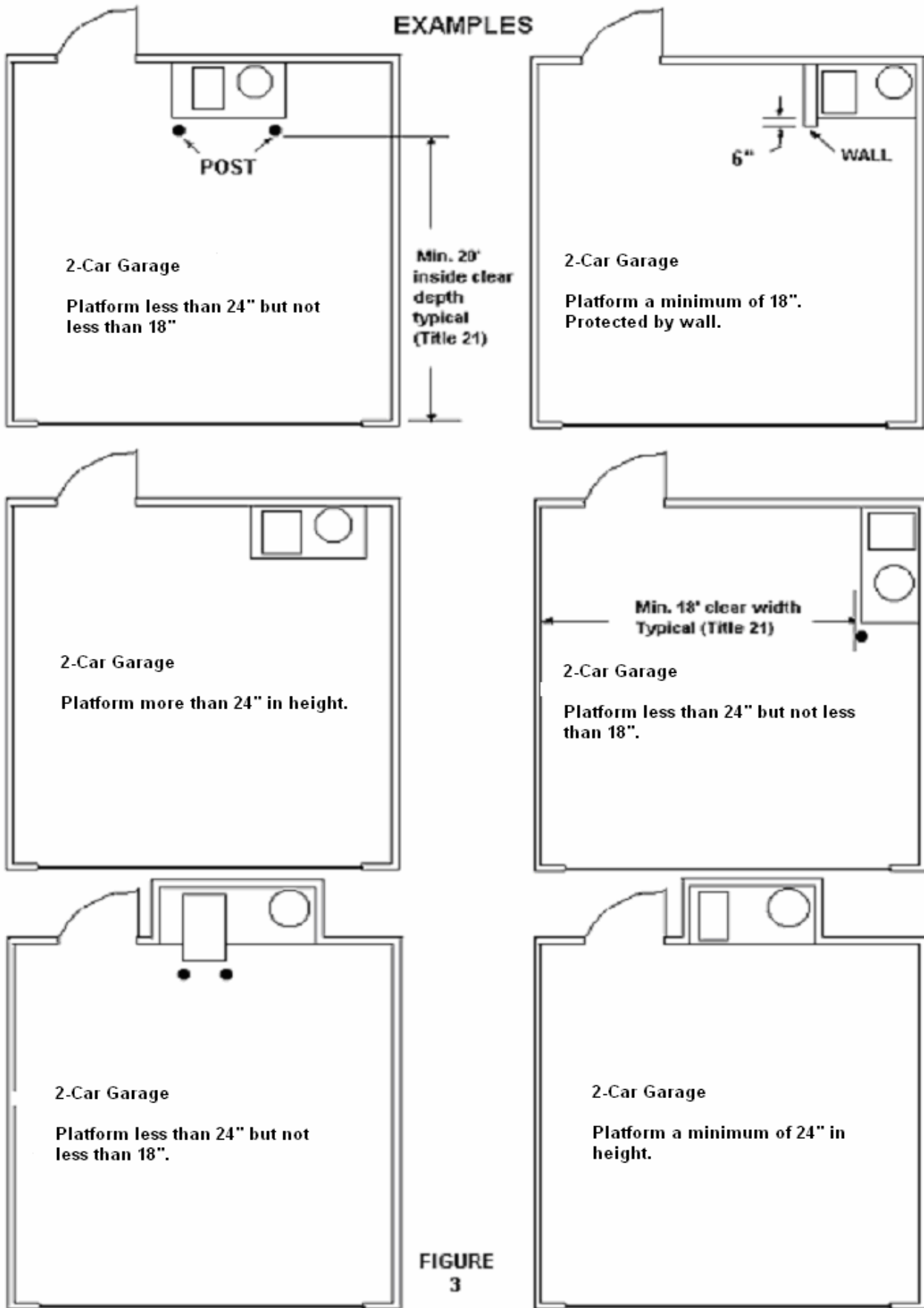

FIGURE 3