



Municipality of Anchorage

Traffic Department



ADDENDUM



Traffic Sign Manual



In accordance with the Alaska Traffic Manual (ATM), all traffic control signs installed on state roads are required to conform to the ATM. Traffic control signs on roads under municipal jurisdiction are required to conform to the ATM "as far as practicable." Uniformity of type, size, and use of signs on all roads promotes understandability and leads to a safer and more efficient transportation network. In this spirit, private property owners are encouraged to conform to the same standards when installing devices on roads that are on private property.

The ATM is comprised of the Alaska Traffic Manual Supplement and the Manual on Uniform Traffic Control Devices Millennium Edition (MUTCD). Within the Municipality the Municipal Traffic Engineer is given authority in Anchorage Municipal Code Title 9 for the placement and maintenance of all traffic control devices. Anchorage Municipal Code Title 21 provides authority for the Municipal Traffic Engineer to review all building permits and site plans to ensure on-site circulation is safe. In this effort, all traffic control devices installed within Municipal jurisdiction must conform to the standards and requirements set forth in the ATM and the MUTCD.

In the effort to provide uniformity, the Alaska Department of Transportation and Public Facilities has published the Alaska Sign Design Specifications (ASDS) manual. The manual is available for free download from <http://www.dot.state.ak.us/stwddes/dcstraffic/asdsintro.shtml>. This manual is hereby adopted for the design of traffic control signs within the Municipality of Anchorage. Following is a short Addendum of additional signs used within the Municipality. Copies of this addendum are available for free download from <http://www.muni.org/traffic/indexsafety.cfm>. Hardcopies can be requested from the Municipality of Anchorage Traffic Department located at 4700 S. Bragaw Street, Anchorage, Alaska 99507.

Please note, all signs should be installed using Telspar posts in accordance with the attached mounting and installation details.

If you have any questions about the installation of traffic control signs, please call the Traffic Department at 343-8406.

Robert E. Kniefel, P.E.
Municipal Traffic Engineer

REGULATORY



R1-2P
30" X 12"



R5-2P
24" X 8"

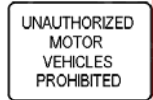

R5-3A
30" X 24"



R7-107M
18" X 18"



R7-108R
12" X 18"



R7-118
12" X 18"



R7p-113
12" X 18"



R7p-113H
12" X 18"



R7p-113T
12" X 18"



R7p-114
12" X 18"



R7p-114T
12" X 18"



R7p-115
12" X 18"



R7p-123
12" X 18"



R7p-125
12" X 18"



R7p-134
12" X 36"



R7p-141
12" X 18"



R7-201
12" X 6"



R7-203D
12" X 6"



R7-203L
12" X 6"



R7-203R
12" X 6"



R7-203T
12" X 6"



R10-11E
30" X 30" Post
36" X 36" Overhead



R10-11F
30" X 30" Post
36" X 36" Overhead



R10-100U
30" X 36"

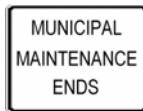

R11-12
30" X 24"

WARNING



W16-1C
18" X 18"



W17-1
24" X 24"

SCHOOL

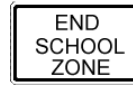

S5-2B
24" X 18" 25-30 MPH
30" X 24" 35-45 MPH
36" X 30" 50-55 MPH

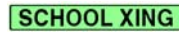

W16-10p
36" X 8"



S6-2
24" X 18" 25-30 MPH
30" X 24" 35-45 MPH
36" X 30" 50-55 MPH

OBJECT MARKERS

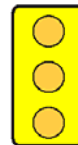

OM2-1V
6" X 15"

MISCELLANEOUS



DTA-1
30" X 30"



DTA-2
30" X 30"



D3-1P
See specifications
Below



D13-3
12" X 18"



NW-1
24" X 36"



D11-2
12" X 18"

NOTE: Within the Municipality of Anchorage, all street signs, except the D3-1P used in conjunction with private streets, shall be D3-1D series when post mounted.

Private Street Sign Specification

Private Street Sign Specifications

The Municipality of Anchorage Traffic Department has established the following guidelines for the production and installation of a 'private' street sign (D3-1P). The lower portion of the sign should follow the standard 8" D3-1D guidelines as set forth in the Alaska Department of Transportation and Public Facilities Alaska Sign Design Specifications – see attached. All streets and roadways designated as 'private' must adhere to the following guidelines.

D3-1P 'PRIVATE' STREET SIGN

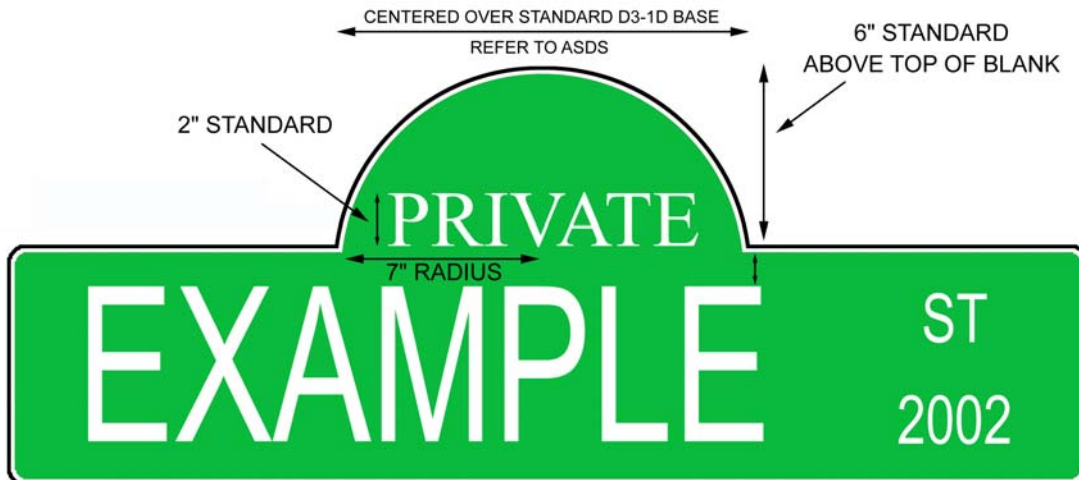

NOTE: All signs should be installed on Telspar posts in accordance with the attached mounting and installation details.

D3-1D

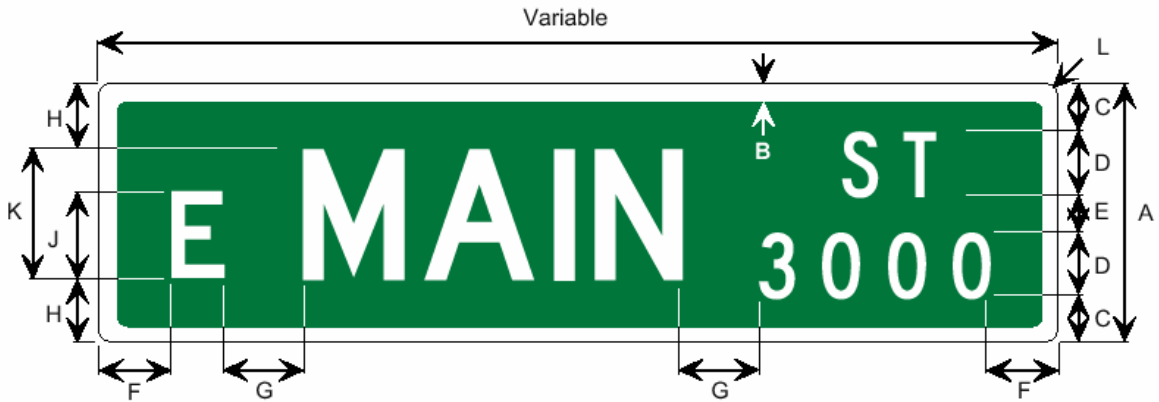

Border and Legend: White
Background: Green

Print legend on both
sides of sign.

* Letters may be series B, C, or D.

Road Class	Dimensions (inches)										
	A	B	C	D	E	F	G	H	J	K	L
Local Rds w Spd Limits <= 25MPH	8	0.5	1.5	2*	1	2	3	2	3*	4*	1.5
All Other Roads	12	0.5	2.0	3*	2	3	4	3	4*	6*	1.5

Installation Details

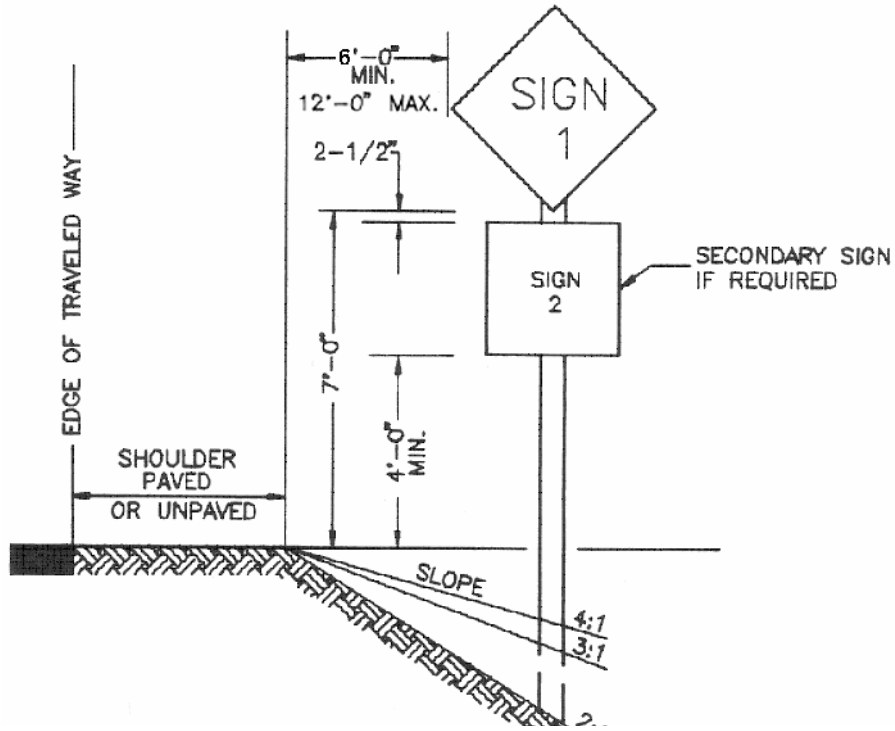

Sign Placement Shoulder Without Curb

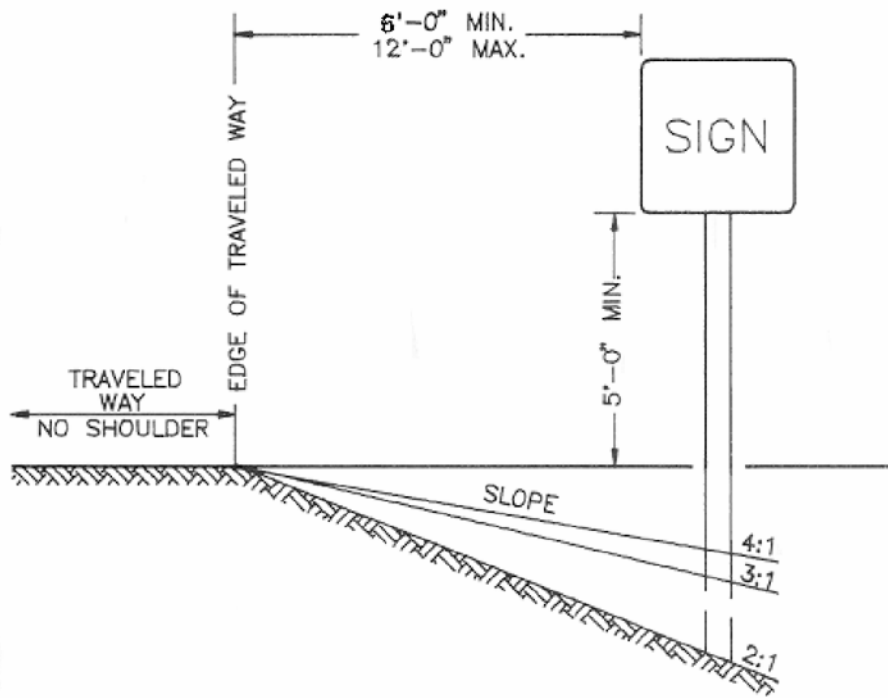

Sign Placement No Curb Or Shoulder

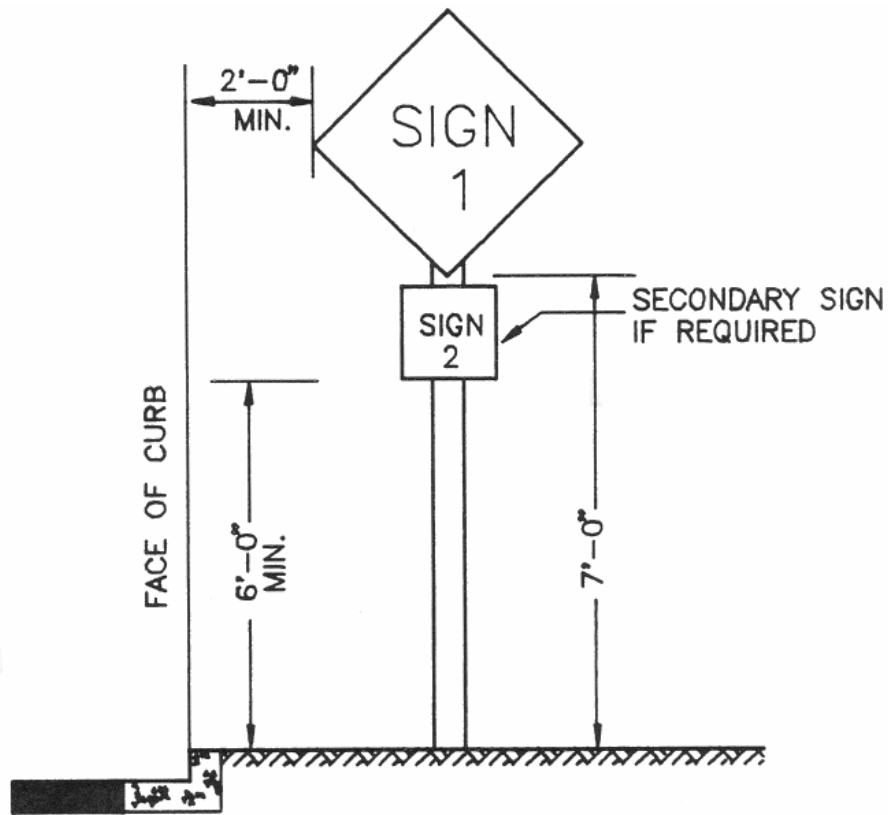

Sign Placement Curb Without Sidewalk

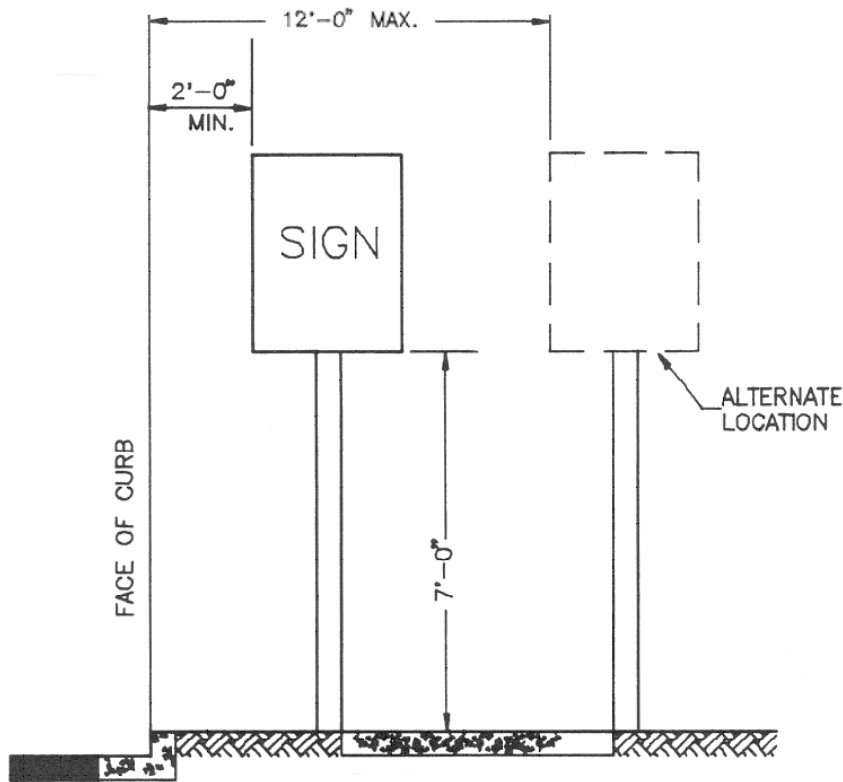

Sign Placement Curb With Sidewalk and Parkway

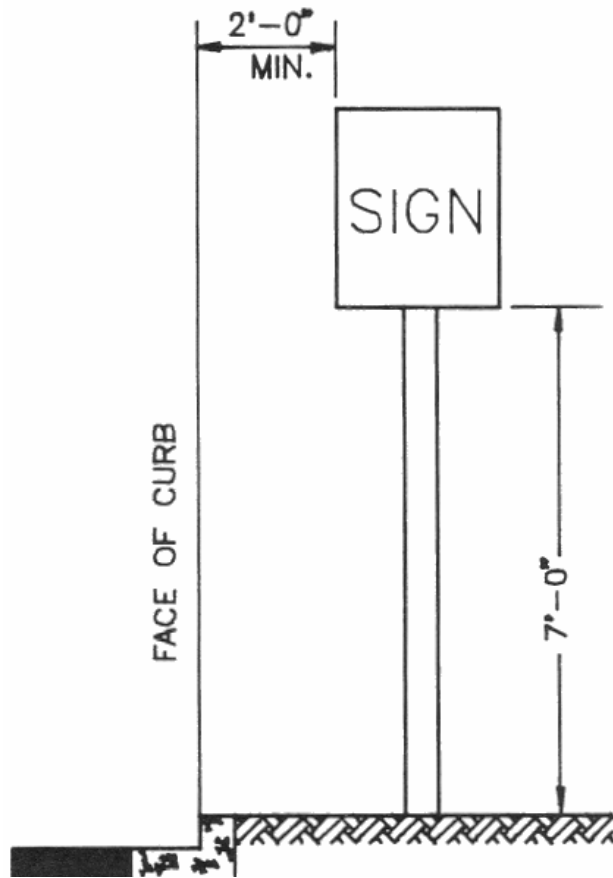

Sign Placement Curb With Sidewalk

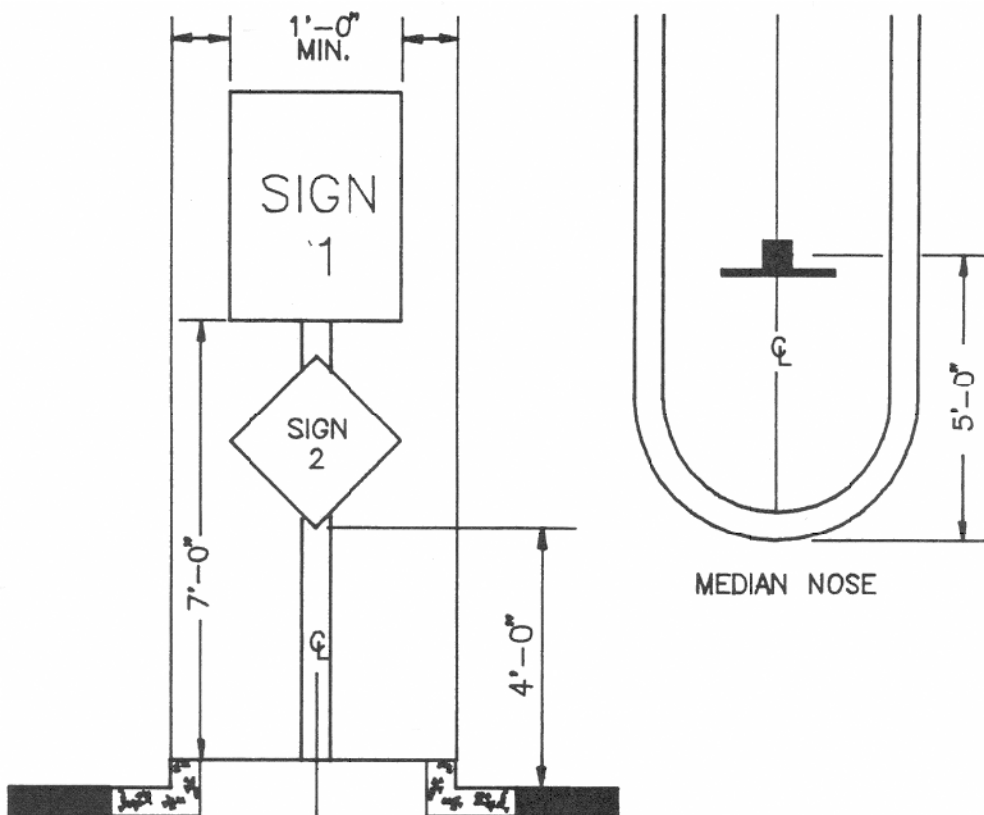

Sign Placement Medians

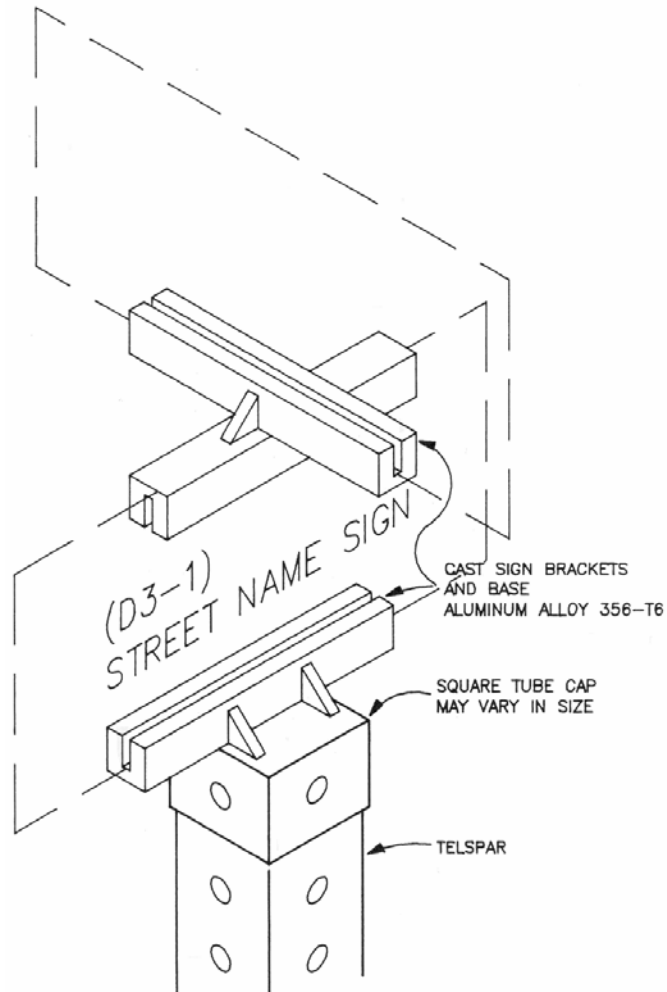

Street Name Signs

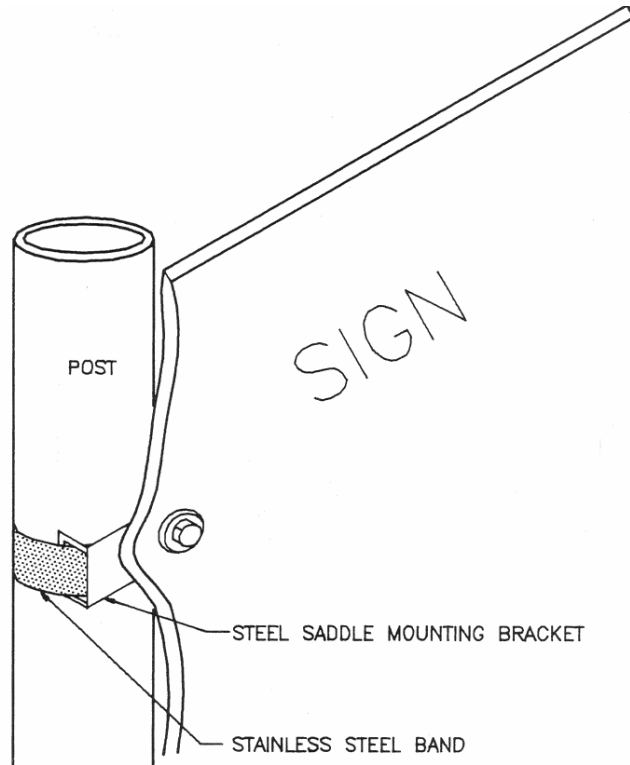

Sign on Existing Post

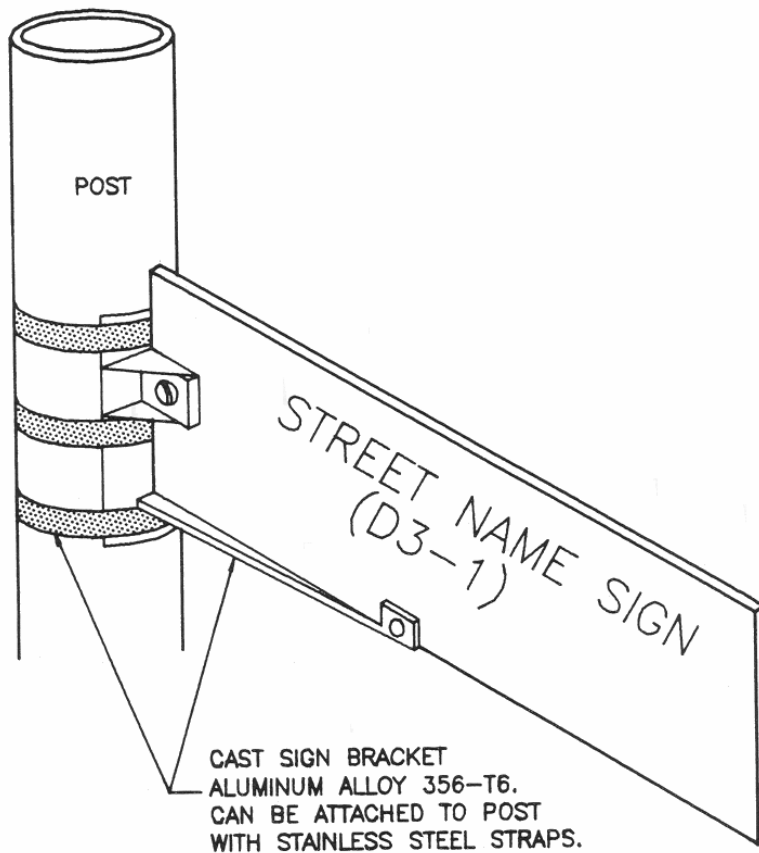

Street Name on Existing Post

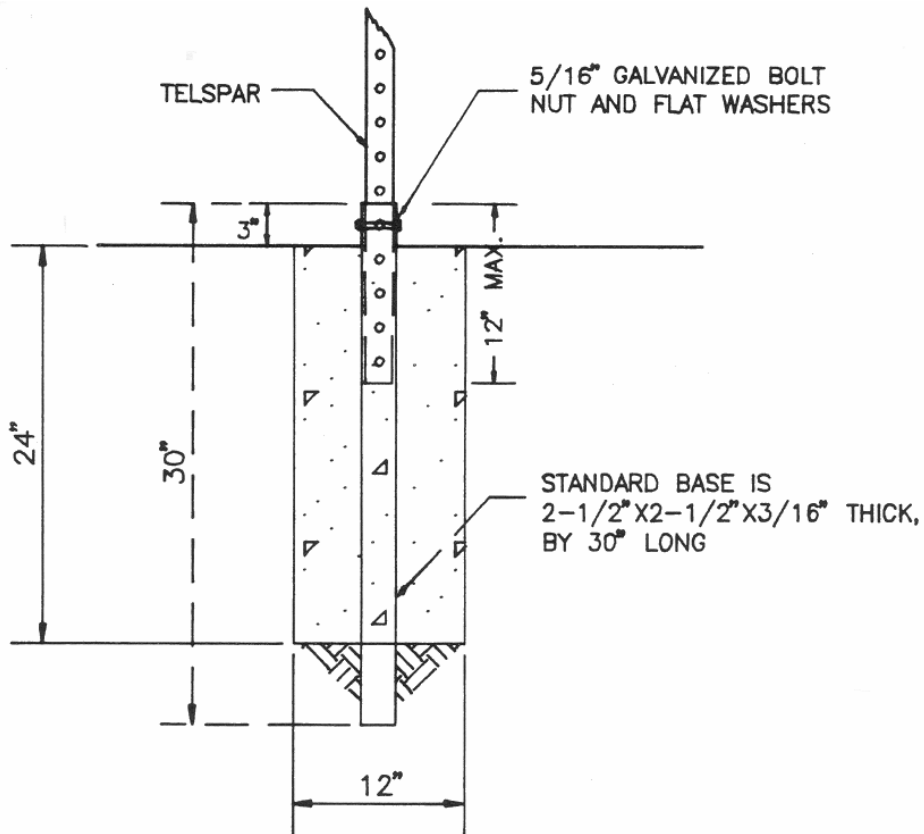

Concrete Foundation for Sign Post

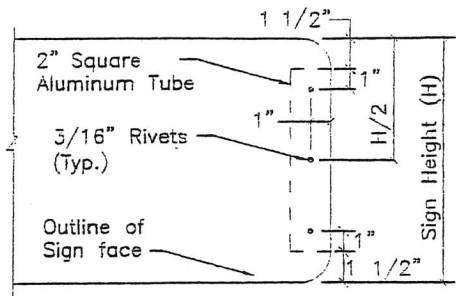

VIEW C - C

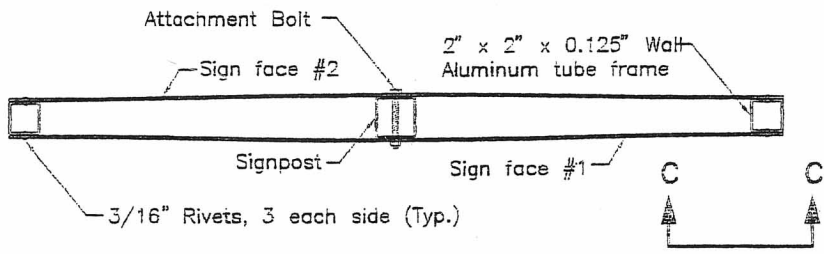

FOR 12" SIGNS/PLATES GREATER THAN 36" IN LENGTH

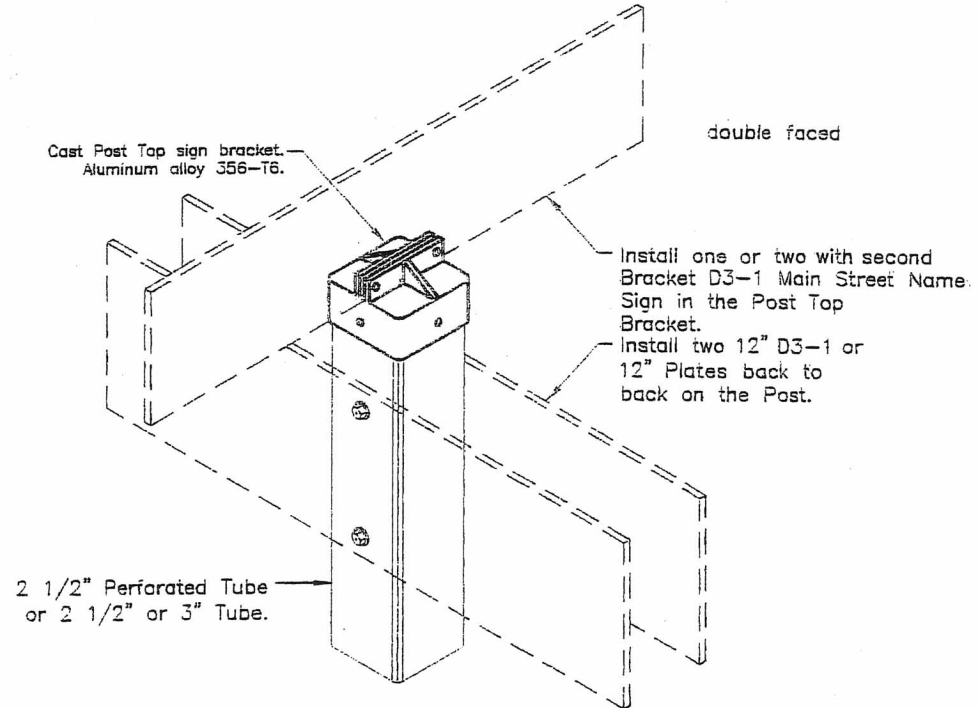

12" PLATE INSTALLATION DETAIL WITH SUPPLEMENTAL 8" D3-1D SIGNS