

**STANDARD CONSTRUCTION SPECIFICATIONS
FOR TRAFFIC SIGNALS AND ILLUMINATION
DIVISION 80
INDEX**

SECTION 80.01	GENERAL.....	1
Article 1.1	Scope of Work.....	1
Article 1.2	Regulations and Codes.....	1
Article 1.3	Equipment List(s) and Drawings	2
Article 1.4	Warranties, Guarantees and Instruction Sheets	3
Article 1.5	Maintaining Existing and Temporary Electrical Systems.....	3
Article 1.6	Scheduling of Work.....	7
Article 1.7	Safety Precautions	7
Article 1.8	Definitions	7
Article 1.9	Signs	8
Article 1.10	Measurement	8
Article 1.11	Basis of Payment	8
SECTION 80.02	EXCAVATING AND BACKFILLING	9
Article 2.1	General	9
Article 2.2	Construction	9
Article 2.3	Sawcut Trench	9
Article 2.4	Measurement	10
Article 2.5	Basis of Payment	11
SECTION 80.03	REMOVING AND REPLACING IMPROVEMENTS	12
Article 3.1	General	12
Article 3.2	Measurement	12
Article 3.3	Basis of Payment	12
SECTION 80.04	FOUNDATIONS	13
Article 4.1	General	13
Article 4.2	Cast-In-Place Concrete Foundations	13
Article 4.3	Load Center Foundation	15
Article 4.4	Controller Cabinet Foundation	16
Article 4.5	Driven Pile Foundation.....	16
Article 4.6	Measurement	16
Article 4.7	Basis of Payment	17
SECTION 80.05	POLES, STEEL PEDESTALS AND POSTS	18
Article 5.1	General	18
Article 5.2	Plumbing.....	21
Article 5.3	Grouting for Slip-Base Poles.....	21
Article 5.4	Galvanizing	22
Article 5.5	Measurement	22
Article 5.6	Basis of Payment	23

SECTION 80.06	MAST ARMS.....	24
Article 6.1	General	24
Article 6.2	Measurement	25
Article 6.3	Basis of Payment	26
SECTION 80.07	CONDUIT.....	27
Article 7.1	General	27
Article 7.2	Measurement	29
Article 7.3	Basis of Payment	30
SECTION 80.08	JUNCTION BOXES.....	31
Article 8.1	General	31
Article 8.2	Materials	31
Article 8.3	Construction	31
Article 8.2	Measurement	32
Article 8.3	Basis of Payment	33
SECTION 80.09	EXPANSION FITTINGS.....	34
Article 9.1	General	34
Article 9.2	Measurement	34
Article 9.3	Basis of Payment	34
SECTION 80.10	CONDUCTORS	35
Article 10.1	General	35
Article 10.2	Control Cables	36
Article 10.3	Power Conductors and Cables.....	36
Article 10.4	Detector Loops and Lead-In Cables.....	37
Article 10.5	Telemetry Cable.....	38
Article 10.6	Measurement	38
Article 10.7	Basis of Payment	39
SECTION 80.11	WIRING.....	40
Article 11.1	General	40
Article 11.2	Measurement	42
Article 11.3	Basis of Payment	42
SECTION 80.12	FUSED SPLICE CONNECTORS.....	43
Article 12.1	General	43
Article 12.2	Measurement	43
Article 12.3	Basis of Payment	43
SECTION 80.13	BONDING AND GROUNDING.....	44
Article 13.1	General	44
Article 13.2	Measurement	45
Article 13.3	Basis of Payment	45

SECTION 80.14	LOAD CENTERS	46
Article 14.1	General	46
Article 14.2	Illumination Control	48
Article 14.3	Step Up/Step Down Transformer	49
Article 14.4	Pad-Mounted Load Center	50
Article 14.5	Post-Mounted Load Center, Type 2 - Underground Service	50
Article 14.6	Post-Mounted Load Center, Type 3 - Overhead Service	51
Article 14.7	Single-Meter Pad-Mount Load Center, Type 1 & 1A.....	51
Article 14.8	Measurement	51
Article 14.9	Basis of Payment	52
SECTION 80.15	WOOD POLES.....	53
Article 15.1	General	53
Article 15.2	Measurement	53
Article 15.3	Basis of Payment	54
SECTION 80.16	MISCELLANEOUS.....	55
Article 16.1	Sign Switches.....	55
Article 16.2	Field Tests	55
Article 16.3	Galvanizing	56
Article 16.4	Painting for Steel Structures	57
Article 16.5	Measurement	59
Article 16.6	Basis of Payment	59
SECTION 80.17	CONTROLLER ASSEMBLIES.....	60
Article 17.1	General	60
Article 17.2	Controller Unit.....	60
Article 17.3	Standard Auxiliary Equipment.....	71
Article 17.4	Special Auxiliary Equipment.....	73
Article 17.5	Controller Cabinet	79
Article 17.6	Operation	86
Article 17.7	Shop Tests.....	86
Article 17.8	Installation	87
Article 17.9	Measurement	88
Article 17.10	Basis of Payment	88
SECTION 80.18	VEHICLE DETECTORS.....	89
Article 18.1	Loop Detectors.....	89
Article 18.2	Optical Detectors - Preemption	92
Article 18.3	Radar Detectors	93
Article 18.4	Ultrasonic Detectors - Ultrasonic Presence Sensors.....	94
Article 18.5	Video Detectors.....	95
Article 18.6	Measurement	95
Article 18.7	Basis of Payment	95

SECTION 80.19	VEHICLE SIGNAL HEADS	96
Article 19.1	General	96
Article 19.2	Installation	97
Article 19.3	Signal Head Mounting	98
Article 19.4	Light Emitting Diode (LED) Optical Units	100
Article 19.5	Incandescent Optical Units	103
Article 19.6	Backplates	104
Article 19.7	Signal Head Mounting Hardware	104
Article 19.8	Programmed Visibility Traffic Signal Heads	105
Article 19.9	Measurement	106
Article 19.10	Basis of Payment	107
SECTION 80.20	PEDESTRIAN SIGNALS.....	108
Article 20.1	General	108
Article 20.2	Installation	108
Article 20.3	Mounting	109
Article 20.4	Housing.....	109
Article 20.5	Light Emitting Diode (LED) Pedestrian Signal Modules	110
Article 20.6	Measurement	113
Article 20.7	Basis of Payment	114
SECTION 80.21	PEDESTRIAN PUSHBUTTONS	115
Article 21.1	General	115
Article 21.2	Measurement	115
Article 21.3	Basis of Payment	115
SECTION 80.22	FLASHING BEACONS.....	116
Article 22.1	General	116
Article 22.2	Measurement	117
Article 22.3	Basis of Payment	118
SECTION 80.23	LUMINAIRES	119
Article 23.1	General	119
Article 23.2	Light Distribution	119
Article 23.3	Measurement	120
Article 23.4	Basis of Payment	120
SECTION 80.24	BALLASTS	121
Article 24.1	General	121
Article 24.2	Measurement	121
Article 24.3	Basis of Payment	121
SECTION 80.25	FALSEWORK LIGHTING.....	122
Article 25.1	General	122
Article 25.2	Measurement	123
Article 25.3	Basis of Payment	123

SECTION 80.26	INTERCONNECT CABINET	124
Article 26.1	General	124
Article 26.2	Measurement	124
Article 26.3	Basis of Payment	124
SECTION 80.27	PROTECTIVE POST ASSEMBLY	125
Article 27.1	General	125
Article 27.2	Measurement	125
Article 27.3	Basis of Payment	125
SECTION 80.28	SALVAGING ELECTRICAL EQUIPMENT	126
Article 28.1	General	126
Article 28.2	Measurement	127
Article 28.3	Basis of Payment	127

**STANDARD CONSTRUCTION SPECIFICATIONS
FOR INSTALLATION AND REMOVAL OF
TRAFFIC SIGNALS AND ILLUMINATION
DIVISION 80**

SECTION 80.01 GENERAL

Article 1.1 Scope of Work

Work shall consist of furnishing and installing, modifying, removing or salvaging one or more traffic signal systems, flashing beacon systems, illumination systems, sign illumination systems, traffic count stations, electrical equipment on structures, falsework lighting, partial installations for future systems, or combinations thereof, all as required by the Drawings, and as specified. All necessary labor and equipment to provide fully functioning traffic signals, intersection lighting, or roadway illumination is included.

Prior to installation of foundations, junction boxes, and conduits; Contractor shall locate and protect all new and existing underground utilities; including, but not limited to, pipelines, signal systems, thaw wires, lighting systems, storm drain, sanitary sewers, water systems, and telephone, cable television, and electrical cables. Not all of the existing utilities may be present or shown on the Drawings. Contractor shall adjust foundation, junction box, or conduit location if conflict exists with either existing utilities or proposed improvements. No additional monies is paid or owed to Contractor for the adjustment.

Materials furnished shall be new, except such used materials as may be specifically provided for on the Drawings or in the Special Provisions. Where an existing system is to be modified, the existing material shall be reused on the project, or disposed of as shown in the Drawings, or specified in the Special Provisions.

All systems shall be complete and in operation with all materials in conformance with Drawings, Specifications and the manufacturer's specifications and recommendations, at the time of final acceptance.

Article 1.2 Regulations and Codes

All material, and workmanship where applicable, shall conform to the standards of the Underwriters Laboratories, Inc., the National Electrical Code, and the National Electrical Safety Code together with local amendments. Within this Division, the term "Code" shall mean the National Electrical Code, and the National Electrical Safety Code together with local amendments.

Where applicable, all electrical equipment shall conform to the standards of the National Electrical Manufacturers Association.

The 1994 Edition of the "Standard Specifications for Structural Supports for Highway Signs, Luminaires and Traffic Signals" published by the American Association of State

Highway and Transportation Officials (AASHTO) shall be referred to in this Division as the 1994 AASHTO design criteria.

Article 1.3 Equipment List(s) and Drawings

- A. The Contractor shall submit for review and approval, within thirty (30) days following award of the Contract, eight (8) collated copies of a portfolio of equipment and materials which he proposes to install. The portfolio(s) shall consist of a table of contents which includes each item's intended use(s) and the following:
1. For materials on the Approved Products List: a description that includes product name, manufacturer, model or part number, and the conditions listed for approval.
 2. For materials not on the Approved Products List: catalog cuts that include the manufacturer's name, type of product, size, model number, conformance specifications, and supplemented by other data as may be required, including manufacturer's maintenance and operations manuals, or sample articles.
 3. A wind stress certificate from the manufacturer of poles, signal mast arms, and luminaire arms. Contractor shall submit to the Engineer for approval the Wind Stress Certificate that includes the signed stamp of a professional engineer registered in the State of Alaska; and a statement that indicates that the poles and mast arms meet the wind and mast arm loading requirements specified in Section 80.05, Article 5.1 - General.
 4. Contractor shall submit to the Engineer for approval the Materials Certifications for all lighting poles, signal poles, mast arms, connector bolts and anchor bolts, indicating that the steel and galvanizing conform to the requirements in this Division.

The Municipality will not be liable for any material purchased, labor performed, equipment used, or delay to the Work before all equipment and materials have been reviewed and approved.

- B. Two (2) paper copies and one electronic copy of traffic signal controller cabinet schematic wiring diagrams shall be submitted at the time the controllers are delivered for testing, or if ordered by the Engineer, prior to purchase. This diagram shall show the location and phasing of the intersection; list of all equipment installed in each cabinet, and show in detail all circuits, parts, and schematic wiring. Contractor shall also provide at this time, two (2) reproducible and one (1) electronic set of Operation and Maintenance manuals and wiring diagrams of any cabinet equipment utilized. These manuals shall show in detail all circuits and parts. Such parts shown thereon shall be identified by name or number and in such a manner as to be readily interpreted.

C. The Contractor shall prepare five (5) complete sets of red lined as-built plans which shall be kept current with the construction. These as-built plans shall detail all construction changes made to the Drawings and also include the following information on each appropriate drawing:

1. Location and depth of conduit runs.
2. Station and offset of all junction boxes.
3. Heights of signal faces and overhead signs.

Copies of such as-built plans shall be furnished at least twice a month during construction so that they may be reviewed for accuracy and completeness. The Contractor shall furnish any additional information required to clarify the as-built plans and shall correct all discrepancies. Progress payment for the signal and illumination Work completed shall not be made until accurate as-built plans reflecting the construction progress have been reviewed and deficiencies corrected.

D. Prior to final inspection of the Work, Contractor shall submit five (5) complete sets of Record Drawings to the Engineer. The Engineer will deliver one (1) copy each to Project Management & Engineering; Traffic Department, Signals Section; Traffic Signal Electronics Shop; Maintenance & Operations, Street Light Maintenance Supervisor; and attach the appropriate sheets of the fifth set in clear envelopes to the inside of each load center.

Article 1.4 Warranties, Guarantees and Instruction Sheets

Manufacturers' warranties, guaranties, instruction sheets and parts furnished with materials used in the Work shall be delivered to the Engineer.

For equipment brands and models not currently in use within the Municipality of Anchorage, a manufacturer's representative shall be present to supervise the turn on and adjustment of the signal system. In addition, the representative shall provide one workday of continuous instruction and familiarization in the operation and maintenance of the signal system.

Article 1.5 Maintaining Existing and Temporary Electrical Systems

The Contractor shall maintain the traffic signal and highway lighting systems from the time of the Notice to Proceed until the time of final acceptance except during any authorized stoppages when the Municipality of Anchorage shall assume maintenance. Temporary replacement equipment furnished by the Contractor shall be compatible with existing equipment used in the M.O.A. and approved by the Engineer. Representatives of the Contractor and the Owner shall inspect the project prior to the winter shutdown and prior to spring start-up to ascertain those items that need repair and determine responsibility for the repairs. If the project includes traffic signal Work, Traffic Signal personnel shall be included in the inspection.

The existing Traffic Signal installation may not be shutdown between 7:00 and 8:30 a.m. or 3:00 and 6:00 p.m. weekdays.

The local traffic enforcement agencies and Traffic Department, Signals Section shall be notified prior to any operational shutdown of a traffic signal system.

The Contractor and the Traffic Signal personnel shall do a walk-through inspection of the existing traffic signal system prior to commencing Work.

The Contractor shall provide temporary signalization. At no time shall a signalized intersection operate in an unsignalized mode, except for shutdown due to change over from the existing system to a temporary system, and from the temporary system to a permanent system. Temporary signal system shutdowns shall be limited to periods during normal working hours as specified in this Section, during which flag control shall be used.

The temporary signal system plan shall be submitted to and approved by the Municipal Traffic Engineer or assigned designee prior to implementation. The temporary signal plan shall equal or exceed the system being replaced or modified. That is, the plan shall not downgrade the number of signal heads, signal phases, pedestrian push buttons, etc. The temporary signal system plan shall also include the layout of the temporary intersection. The complete plan shall include intersection geometrics, lane widths, and auxiliary lane pocket lengths.

No vehicle detection will be required in a temporary system, unless called for in the Drawings and Specifications or specified by the Traffic Department. The Contractor shall coordinate all Signal Work with the Traffic Signal Section or the assigned designee at 343-8355.

The Contractor shall be responsible for maintaining any span wire temporary signal installed. The Traffic Department will not assume maintenance responsibility for span wire systems.

The Contractor shall obtain Traffic Department approval prior to turning any maintenance responsibilities over to the Traffic Department, including any maintenance required during Winter Shutdown.

The Contractor shall furnish and install all materials and miscellaneous hardware required to provide a functional traffic signal system. All materials shall conform to the requirements of the Drawings and Specifications. Temporary equipment shall be compatible with existing equipment used in Anchorage.

The temporary signal system may consist of any combination of the following:

1. The existing systems,
2. Relocation of component parts,
3. Guyed wood poles, or

4. Any portion of the permanent signal system.

Traffic signals may be suspended from messenger cables provided that they are mounted by standard span wire hangers and secured with a second cable (tether wire) to prevent misalignment in the wind. Messenger cables shall be at least three-eighths inch (3/8") O.D. "High Tensile" grade cable. Tether wire shall be one-eighth inch (1/8") O.D. steel cable installed with a minimum ground clearance of nineteen feet (19'). All signal faces shall be equipped with backplates and visors. The signal faces of each phase with two or more faces shall be energized using two (2) circuits, with each circuit wired with IMSA 20-1 signal cable. Splices shall be made only at the terminal blocks in the signal faces. Sufficient signal cable slack shall be left at each pole to provide for drip loops and to allow realignment of each signal head.

Whenever a pole of the permanent signal system is included in a span wire signal system, the Contractor shall guy the pole and provide protective collars to prevent chafe damage. Poles with breakaway bases shall not be included in a span wire supported signal system.

The Contractor shall provide illumination at all locations with preexisting lighting and at all intersections where temporary traffic signalization is specified to be provided.

The temporary facilities shall be provided during the life of the Contract on all roadways open to traffic within project limits. The temporary lighting systems shall be operational by sunset on the same day the replaced system is retired, or the roadway is opened to traffic.

A plan for each temporary lighting system shall be submitted to and approved by the Engineer prior to implementation. The temporary lighting plan shall equal or exceed the system(s) being replaced or modified. At intersections, the temporary system shall include a luminaire located on the far right for each through street approach and installed adjacent to the through street radius returns. The through street is the street with the vehicular right of way; both streets shall be considered through at signalized intersections and four-way stops.

The Contractor shall furnish and install all materials and miscellaneous hardware required to provide a functional lighting system including electrical load centers. All materials shall conform to the requirements of the Drawings and Specifications, except that the branch conductors may be triplex aluminum with messenger cable if they are installed overhead. Illumination conductors shall be sized so that the voltage at the most remote luminaire is not less than the minimum required for the ballast as recommended by the manufacturer. The Contractor shall install intermediate conductor and supports to energize luminaires at locations without electrical service.

Luminaires used in the system may be the existing fixtures or new fixtures with a light distribution compatible with the proposed lighting configuration.

The temporary lighting systems may consist of any of the following lighting pole types, or combinations thereof, provided the luminaires have a minimum of thirty feet (30') mounting height. Mounting height is the difference in elevation between the luminaire retractor and

the edge of traveled way at the same station. The existing poles may be reused if they are not utility owned. Any pole of the permanent lighting and temporary signal systems and any Contractor-supplied poles may be wood and shall meet 1994 AASHTO design criteria for one-hundred-mile-per-hour (100 mph) winds with gusts to one hundred thirty miles per hour (130 mph). All poles, except traffic signal poles, installed within the clear zone shall be provided with FHWA approved slip bases, transformer bases, or frangible couplings.

The load centers to power the temporary lighting and signal systems may be the permanent installations, the existing installations, or temporary installations. The existing load centers may be used only if they are scheduled to remain intact until completion of the project, and reused only if they are approved. The Contractor shall provide approved temporary load centers with photoelectrically-controlled lighting circuits whenever a load center is unavailable for use, or when an existing load center that is not approved is retired due to conflict with the Work. An approved load center is any load center UL labeled as Service Equipment, or UL labeled as Industrial Control Equipment and marked "suitable for use as service equipment." The Contractor shall provide all Work to modify these load centers as required to provide functional temporary lighting and signal systems, and to install them completing all Work in accordance with the NEC.

Once the Contractor commences Work on the project, he shall provide all maintenance for the existing electrical facilities. The Municipality will pay for the electrical power for the above-mentioned electrical systems. The above maintenance does not include any prior damage such as burned out lamps, non-operative detection or other malfunctioning equipment. The Contractor shall present written documentation of all non-functioning and malfunctioning electrical equipment before commencing Work on the project. This malfunctioning equipment shall be inspected jointly by personnel from the Engineer's staff and the Contractor. In the event the Engineer does not receive notice in writing and the Contractor begins Work on the project, this will suffice as evidence that all equipment is functional and operational.

The Contractor shall furnish the Engineer with the name and phone number of the person responsible for maintaining existing and temporary electrical facilities. Repair work shall commence within one hour of notification for traffic signal systems.

The exact location of existing conduit runs, direct burial cable, pull boxes, and all underground utilities shall be ascertained by the Contractor before using equipment that may damage such facilities or interfere with any system.

Where roadways are to remain open to traffic and existing lighting systems are to be modified, the lighting systems shall remain in operation and the final connection to the modified circuit shall be made so that the modified circuit will be in operation by nightfall of the same day the final connection is made.

Temporary electrical installations shall be kept in effective operation until no longer required. Removal of temporary installations shall conform to the provisions in Section 80.28 – Salvaging Electrical Equipment.

These provisions will not relieve the Contractor in any manner of his responsibilities as provided in Division 10, Section 10.06 - Legal Relations and Responsibilities.

Article 1.6 Scheduling of Work

Work shall be so scheduled that each new traffic signal system, highway lighting system, and sign illumination system shall be completed and ready for operation prior to opening to traffic of the corresponding section of new alignment.

Traffic signal systems shall not be placed in operation without energizing the street lighting at the intersection to be controlled if street lighting exists or is being installed with the traffic signals.

Contractor shall not place traffic signal systems into operation. Traffic Signal personnel are the only persons authorized to turn on a traffic signal.

Conductors shall not be pulled into conduit until pull boxes are set to grade, crushed rock sumps installed, grout placed around the conduit, and metallic conduit bonded.

In vehicular undercrossings, soffit lights shall be placed in operation as soon as practicable after falsework has been removed from the structure. Lighting for pedestrian structures shall be placed in operation prior to opening the structure to pedestrian traffic.

If the Engineer orders soffit lights or lighting for pedestrian structures placed in operation before permanent power service is available, the cost of installing and removing temporary power service will be paid for as extra Work as provided in Division 10, Sections 10.05 – Control of Work and 10.07 – Measurement and Payment.

Article 1.7 Safety Precautions

Before starting Work on existing series street lighting circuits, the Contractor shall obtain daily, a safety circuit clearance from the serving utility. By-pass switch plugs must be pulled and suitable signs posted at switch boxes before electrical Work begins.

Suitable signs shall be posted at Load Centers when a contractor is working on any of the circuits from that Load Center.

Article 1.8 Definitions

The Definitions in NEMA TS-1, Traffic Control Systems, Part I, shall be used along with the following:

1. Electrolier: The complete assembly of pole, mast arm, luminaire, ballast, and lamp.
2. Luminaire: The assembly which houses the light source and controls the light emitted from the light source. Luminaires consist of hood (including socket), reflector, and glass globe or refractor.

3. Lighting Standard: The pole and mast arm which must support the luminaire.
4. Vehicle: Any motor vehicle licensed for highway use by the State of Alaska.
5. Controller Unit: The solid-state device as described in Section 80.17, Article 17.2 – Controller Unit.
6. Controller Cabinet: A cabinet constructed, wired and equipped as described in Section 80.17, Article 17.5 - Controller Cabinet.
7. Controller Assembly. The controller cabinet, controller unit and the equipment described in Section 80.17. The controller assembly shall also be functioning in accordance with Section 80.17, Articles 17.1- General and 17.6 - Operation.
8. Anchor bolts apply to Luminaire poles and anchor rods apply to Signal poles. They are used interchangeably in this Division.

Article 1.9 Signs

Reference Division 70, Section 70.11 – Standard Signs.

Article 1.10 Measurement

All Work in this Section shall be measured by lump sum and shall consist of all labor, materials, and equipment necessary to provide temporary signalization and temporary illumination.

Article 1.11 Basis of Payment

Payment for this Work shall be in accordance with Division 10, Section 10.07 - Measurement and Payment, and shall include full payment for all Work described in this Section.

Payment shall be made under the following units:

ITEM	UNIT
Temporary Signalization	Lump Sum
Temporary Illumination	Lump Sum

SECTION 80.02 EXCAVATING AND BACKFILLING

Article 2.1 General

The excavations required for the installation of conductors, conduits, foundations and other appurtenances shall be performed in such a manner as to avoid any unnecessary damage to the streets, sidewalks, landscaping, and other improvements. The trenches shall not be excavated wider than necessary for the proper installation of the electrical appurtenances and foundations. Excavation shall not be performed until immediately before installation of conduit and other appurtenances. The material from the excavation shall be placed in a position that will not cause damage or obstruction to vehicular and pedestrian traffic nor interfere with surface drainage.

Trench, backfill, and disposal of surplus material shall be performed in accordance with Division 20 – Earthwork .

Excavations after backfilling shall be kept well-filled and maintained in a smooth and well-drained condition until permanent repairs are made.

All excavations shall be filled, and sidewalks, pavement, and landscaping restored at each intersection prior to excavating at any other intersection. Excavations in the street or highway shall be performed in such a manner that not more than one traffic lane is restricted in either direction at any time, unless otherwise provided in the Special Provisions.

Article 2.2 Construction

The Contractor shall excavate the trench to the proper depth as described herein and as shown on the Drawings.

The excavations shall be backfilled with material suitable to the Engineer. All backfill placed in the roadway area shall be Type II-A classified backfill as specified in Division 20,, Section 20.21, Article 21.2 - Material. All backfill material shall be placed in uniform layers of not more than six inches (6") in depth and compacted to a density of not less than ninety-five percent (95%) of the maximum density as directed by the Engineer.

The Contractor shall be responsible for the restoration of all surfacing, turf, and native material to the original condition and appearance.

Article 2.3 Sawcut Trench

Where shown on the Drawings, or as directed by the Engineer, the Contractor shall construct a sawcut trench as detailed in the Drawings. A sawcut trench will be used to cross existing traveled lanes, existing curb and gutter, in median islands, along edges of paved roadways, and in sidewalk areas where a neat cut of the surfacing is required.

The Contractor shall cut the surfacing material full-depth and remove the surfacing material to expose the subgrade materials. The Contractor shall then excavate a trench, dispose of excess and waste materials, and install conduit as described herein.

In sawcuts of asphalt pavement located within the roadway pavement, Contractor shall remove a minimum distance of one foot (1') back from the edge of the trench, on each side of the trench. Contractor shall remove pavement such that cuts parallel to the direction of travel are not located within the wheel paths.

The entire trench shall be backfilled as specified herein, except non-frost-susceptible sand bedding material shall be used.

The existing surface shall then be restored with like pavement in accordance with Section 40.07 - Remove and Replace Existing Asphalt Surfacing; Section 40.06 - Tack Coat; Section 30.03 - Portland Cement Concrete Sidewalks; or Section 30.02 Portland Cement Concrete Curb and Gutter, and Valley Gutter, as applicable.

Where applicable, asphalt tack coat shall be applied to all edges of the existing pavement prior to placing new asphalt. Asphalt pavement less than three inches (3") in thickness shall be placed in one lift, and asphalt pavement three inches (3") and greater in thickness shall be placed in a minimum of two equal lifts.

In median islands, the Contractor may elect to remove and replace the entire surface of the island along the length of the conduit run. If the Contractor elects to remove the entire surface of the island, the Work shall still be considered as sawcut trenching. The layer of pavement under the median islands, if encountered (normally at the street pavement grade), may be broken out.

The Contractor shall be responsible for the restoration of all surfacing, turf, and native material to original condition and appearance.

Article 2.4 Measurement

Measurement for trench and backfill and for sawcut trench shall be per linear foot of horizontal distance of the various widths and depths as set forth in the Bid Schedule. Measurement will be from station to station or from center of device to center of device as staked in the field and as shown on the Drawings.

Article 2.5 Basis of Payment

Payment for this Work shall be in accordance with Division 10, Section 10.07 - Measurement and Payment, and shall include full payment for all Work described in this Section.

Work not specifically identified for payment under a separate pay item, but required for normal completion of trench and backfill, will be considered incidental and shall be included in the linear foot cost of the trench. Sawcut trench includes removing existing pavement, trench and backfill, and replacing pavement.

Payment shall be made under the following units:

ITEM	UNIT
Trench and Backfill (Width) (Depth)	Linear Foot
Sawcut Trench (Width) (Depth)	Linear Foot

SECTION 80.03 REMOVING AND REPLACING IMPROVEMENTS

Article 3.1 General

Improvements such as sidewalks, curbs, gutters, Portland cement concrete and asphalt concrete pavement, base material, lawns and plants and other improvements removed, broken or damaged by the Contractor's operations, shall be replaced or reconstructed with the same kind of material as found on the Work or with materials of equal or better quality. The new Work shall be left in a satisfactory serviceable condition.

Whenever a part of a square or slab of existing sidewalk, curb and gutter, or driveway is broken or damaged, the entire square, section or slab shall be removed and the concrete reconstructed as above specified.

The outline of all areas to be removed in concrete sidewalks and driveways and in pavements shall be cut to a minimum depth of one and one-half inches (1 1/2") with an abrasive type saw prior to removing the sidewalk, driveways, and pavement material. The cut for the remainder of the required depth may be made by a method satisfactory to the Engineer. Cuts shall be neat and true with no shatter outside the removal area.

When a foundation is to be abandoned in place, the top of foundation, anchor bolts, and conduit shall be removed to a depth of not less than one foot (1') below surface of sidewalk or unimproved ground. The resulting hole shall be backfilled with material equivalent to and compacted to the density of the surrounding material.

Article 3.2 Measurement

All Work under this section is incidental to other Work and will not be measured or paid for directly.

Article 3.3 Basis of Payment

No separate payment will be made for this item.

SECTION 80.04 FOUNDATIONS

Article 4.1 General

All foundations for poles, posts and pedestals shall be cast-in-place Portland Cement Concrete or driven pile.

Unless otherwise shown on the Drawings, all items to be relocated shall be provided with new foundations and anchor bolts of the proper type and size.

The Contractor shall be responsible for contour grading around all post, pole, and pedestal foundations. Final or finished grading shall be such that the earth shall be two inches (2") below the top of the base and drain away from the base.

Foundations for poles shall be designed for one-hundred-mile-per-hour (100-mph) winds with gusts to one hundred thirty miles per hour (130 mph) in conformance with the requirements of the 1994 AASHTO design criteria.

Cabinet foundations shall be precast.

The entire controller foundation and the top twelve inches (12") of pole or post foundations shall be formed and the top given a smooth steel trowel finish. Conduits shall be located in the center of the pole-post foundations with clearance allowed for bushings.

The tops of all pole foundations shall be set so that the bottom center of the base plates are between four (4") and six inches (6") above finished grade at the pole's offset. The top of any foundation located on a slope shall be constructed such that the finished slope passes through the top center of the uphill edge of the foundation. The area two feet (2') up and down slope of the edge of the foundation shall be graded so that no portion of the foundation projects above the surrounding slope and so that water will drain away from the foundation.

The Contractor shall field-verify pole foundation stationing and elevations prior to pouring the foundations, to insure that the final locations of the signal heads and mast arms meet the requirements of the Drawings and Specifications. The field-verification includes checking to insure that the heads will be the proper distance above the roadway surface, and mast arms will be of adequate length to place heads and signs in the right locations. Any discrepancies shall be reported to the Traffic Engineer prior to pouring the foundation.

Article 4.2 Cast-In-Place Concrete Foundations

The Contractor shall use a minimum 16 gauge corrugated steel pipe (CSP) form to cast concrete foundations in place. The Contractor shall over excavate the area around the form enough to allow for proper compaction. The backfill operation shall conform to the requirements of Division 20, Section 20.19 – Furnish Foundation Backfill. The use of water for drilling operations or for any other purpose where it may enter the hole is not permitted.

Concrete shall be Class AA-3 Portland Cement conforming to Division 30 – Portland Cement Concrete.

Reinforcing steel and wire fabric shall conform to the requirements of Division 30, Section 30.01, Article 1.3 - Materials and Section 80.05 – Poles, Steel Pedestals and Posts. Reinforcement shall be placed and fastened in conformance with Division 30, Section 30.05, Article 5.2 - Construction, except that bars to be spliced shall be lapped at least fifty (50) bar diameters. Where bar spacing is less than one (1) foot in each direction, the Contractor may tie alternate intersections.

Drilled holes or forms shall be vertical, and true to the locations shown in the Drawings. Upon completion of excavation for a foundation, and prior to the placement of concrete, all loose material shall be removed in order that the foundation rests on firm, undisturbed ground.

Forms, if indicated or required, shall be true to line and grade, with the top of the foundation at the established elevation.

Conduit shall be included in all concrete foundations for wire and cable entry as shown on the Drawings as required to complete the Work. The conduit in pole or post foundations shall extend four inches (4") above the foundation (but not above the slip base adapter) and shall be sloped towards the hand-hole opening. These conduits shall exit the foundations in the top center of the foundation surface.

The reinforcing steel cage, if required, shall be placed and secured symmetrically about the vertical axis and shall be securely blocked to clear the sides of the foundation. Anchor bolt assemblies and conduit ends and reinforcing bar assemblies shall be securely supported by templates. Each anchor bolt shall have two (2) nuts and two (2) washers.

Anchor bolts, nuts and washers shall conform to ASTM ,F1554 with grade as specified by manufacturer, and shall be hot-dip galvanized after fabrication in accordance with ASTM A153. Anchor bolts for signal mast arm foundations shall conform to ASTM F1554, The grade of steel shall be as specified by the pole manufacturer, for the loading specified in Section 80.05, Article 5.1 - General. The exposed end of all anchor bolts used for signal mast arm poles shall be clearly stamped with the appropriate markings so that the type of bolts used in the foundation can be clearly determined after construction, per ASTM F1554 supplementary requirements S2 and S3. Signal mast arm foundation anchor bolts shall conform to Charpy Impact Requirements at –20°F, per supplementary requirement S5.Anchor bolts may not be field cut or bent. Damage to galvanized surfaces as a result of damage during shipping or construction activities shall be repaired in accordance with Section 80.16, Article 16.3 - Galvanizing.

Material certifications for all anchor bolts shall be submitted to the Traffic Engineer or designated representative prior to acceptance of the foundations for payment.

Reinforcing bars shall be formed into cages and all intersections tied with #14 AWG steel wire. The cages shall be accurately held in position during placing and setting of the

concrete. All reinforcing bars shall be bent cold in as smooth a curve as possible and shall conform to standard practice of the WCRSI. Reinforcing steel shall not be welded except as shown in the construction detail Drawings.

All reinforcing steel shall have a minimum of one inch (1") of concrete cover for controller cabinet and load center foundations, and three inches (3") of cover for signal pole and luminaire foundations.

Surface water shall not be permitted to enter the hole and all water which may have infiltrated in the hole shall be removed before placing concrete. Both forms and ground shall be thoroughly moistened before placing concrete. Each foundation shall be poured in one continuous pour.

Posts, poles and pedestals shall not be erected or placed on the foundation until ten (10) days after placement of the concrete. If the Engineer approves Type III Portland High-Early-Strength Cement Concrete, then posts, poles and pedestals may be placed on foundations four (4) days after placement of the concrete. Plumbing shall be accomplished by adjusting the nuts on the anchor bolts. Shims or other similar devices for plumbing or raking are not permitted.

After each slip-base post, pole or pedestal is in position, grout conforming to Section 80.05, Article 5.3 – Grouting for Slip-Base Poles, shall be placed under the base plate as shown on the Drawings, and shaped to present a neat appearance. Contractor shall install metal skirting on all non-slip-base posts, poles, or pedestals.

Article 4.3 Load Center Foundation

Excavate sixty inches (60") for base and install eighteen inches (18") of coarse aggregate for drain. Backfill above gravel in six inch (6") lifts with non-frost-susceptible material, compacting to ninety-five percent (95%) in accordance with Division 20 – Earthwork.

Install base so that cast-iron cover is flush with pavement, sidewalk, or finished grade. Slope grade away from base with minimum slope of three percent (3%). Use a pre-molded bituminous joint between base and concrete sidewalk or paving.

Install a three-quarter inch by ten foot (3/4"x10') copper clad ground rod inside the base, readily accessible through the removable steel cover. Install an additional external three-quarter inch by ten foot (3/4"x10') copper clad ground rod eight feet (8') from the load center, and additional ground rods as required by Code or the electrical utility.

Connect cast-iron cover of load center base to the ground rod with six feet (6') of copper braid with eyelets every six inches (6") and approved connectors.

Access opening shall be finished with a twenty-four inch (24") square iron frame and cover, approximately 280 pounds total weight, as provided by Olympic Foundry, Part No. SM70 or approved equivalent.

Install four (4) each, three-quarter inch (3/4") ferrule loop inserts for lifting, two (2) on each long side.

Provide one inch (1") chamfer on all exposed concrete edges.

For two-piece units, seal joint with pre-molded plastic bituminous type joint sealer.

Article 4.4 Controller Cabinet Foundation

Contractor shall install controller cabinet foundation in conformance with Standard Details 80-5, 80-6, 80-7, and 80-8. The top surface of controller cabinet foundations shall be eighteen inches (18") above finished grade and provided with a one inch (1") diameter drain hole connected to the cabinet interior and emptying above the ground line. All conduits shall be placed in the front half (door side) of the foundation to provide adequate wiring terminal block clearances.

Controller cabinet anchor bolts shall be as recommended by cabinet manufacturer and set with a template. Install a three-quarter inch by ten foot (3/4"x10') copper clad ground rod inside the base, readily accessible through the removable steel cover.

Controller cabinet foundations shall be installed in accordance with Section 80.04, Article 4.3, SubArticles 1, 2, 6, 7 and 8.

Article 4.5 Driven Pile Foundation

Contractor shall supply drive pile foundations shall be of the size and length indicated. Contractor shall ensure that the top surface of the anchor plate is three inches (3") above finished grade at luminaire pole locations and five inches (5") above finished grade for signal poles, or as indicated in the Drawings.

After welding on the pile cap adapter and anchor plate to the driven steel pile, Contractor shall cold galvanize the pile cap, the pile cap adapted, anchor plate, and the top three feet (3') of the steel pile including pile cap and anchor plate. Contractor shall furnish

galvanization that complies with Federal Specification DOD-P-210354A (Galvanizing Repair Spec) and is U.L. listed. Contractor shall prepare steel surfaces and apply the cold galvanizing compound in accordance with the manufacturers' recommendations. Five days prior to applying the cold galvanizing compound, Contractor shall provide the Engineer a copy of the manufacturers' instructions.

Article 4.6 Measurement

Foundations will be measured as units, complete and in place.

Article 4.7 Basis of Payment

Payment for this Work shall be in accordance with Division 10, Section 10.07 - Measurement and Payment, and shall include full payment for all Work described in this Section.

Payment will be made under the following units:

ITEM	UNIT
Cast-In-Place Luminaire Pole Foundations	Each
Driven Pile Luminaire Pole Foundations	Each
Controller Cabinet Foundation (Type)	Each
Signal Mast Arm Pole Foundation	Each
Signal Pedestal Pole Foundation	Each
Pedestrian Pushbutton Pole Foundation	Each
Load Center Foundation (Type)	Each
Driven Pile Signal Pole Foundation	Each

SECTION 80.05 POLES, STEEL PEDESTALS AND POSTS

Article 5.1 General

All traffic signal and street lighting poles and arms shall be designed in accordance with the requirements of the 1994 AASHTO design criteria. Minimum Design wind velocity shall be the greater of one-hundred miles per hour (100 mph) or the AASHTO recommendation based upon a fifty (50) year mean recurrence interval dependent upon project location. A factor of 1.3 shall be used in design calculations to account for wind gusts. The minimum design loading for signal mast arm poles shall be as follows:

Load #	Description	Weight (Lbs)	Projected Area (Ft ²)	Centerline Distance From End of Arm (Ft)
1	Sign	65	7.5	0.5
2	Signal	80	14.7	3.5
3	Signal	60	8.7	14
4	Sign	80	26	25 (See note 1)
5	Signal	60	8.7	35 (See note 2)
6	Signal	125	7.6	See note 3
7	Street Name Sign		2.0	See note 4
8	Street Name Sign		2.0	See note 4

Notes:

1. Mast arms shorter than twenty-six feet (26') in length may disregard load #4.
2. Mast arms shorter than thirty-six feet (36') in length may disregard load #5.
3. Load #6 shall be shaft mounted fourteen feet (14') from the base of the pole.
4. Load #s 7 and 8 are shaft mounted twelve feet (12') from the base of the pole.

Should project plan loading develop shear or moments greater than those related to the above loading, special design poles are required. These "Special Design" poles should be designed per the Drawings. All "Special Design" or Type SD poles will require calculation submittal to the Engineer prior to approval for use on the project.

The design for luminaire poles shall include a traffic sign with an area of twelve (12) square feet, located with its centroid nine feet (9') above the base of the pole.

Manufacturer's design calculations and wind stress certification letter shall be submitted to the Traffic Engineer or designated representative prior to approval of all signal poles and mast arms. Such certification shall include the stamp of a registered professional engineer. It shall list the pole numbers and the name of the project, and state that all poles

and mast arms meet or exceed the ability to support the minimum loads specified in Section 80.05, Article 5.1 - General.

Pre-approval of designs is available for poles meeting minimum design loading conditions. Pre-approval is not available for Special Design Poles. Pre-approval of submitted designs shall be at the sole discretion of the Traffic Engineer. Withdrawal of pre-approval may occur at anytime at the sole discretion of the Traffic Engineer. All design calculation submittals shall include the stamp of a Professional Engineer registered in the State of Alaska.

Use of non-compact sections shall not be allowed for any signal mast arm pole or arm. No exceptions shall be made.

All steel and iron products which are incorporated into poles, including connection and anchor bolts, shall be manufactured in the United States. All manufacturing processes starting with initial mixing and melting through the final shaping, welding and coating processes must be undertaken in the United States. Manufacturing includes smelting, rolling, extruding, machining, bending, grinding, drilling, painting and galvanizing. This does not apply to raw materials such as iron ore, pig iron, and processed, pelletized and reduced iron ore.

Material certifications for all poles, mast arms, bolts, steel plates and sheet steel shall be submitted to the Traffic Engineer or designated representative prior to acceptance of the poles and mast arms for payment. All mast arm connection bolts shall meet ASTM A325 and be galvanized in accordance with ASTM A153.

The Contractor shall verify the shaft lengths and mast arm connector plate locations of all poles to insure the Drawing mounting heights of luminaires and traffic heads are met. Traffic Signal personnel shall be allowed to perform an inspection of the poles in conjunction with review of submittals.

Poles less than fifteen feet (15') in length shall be round or multisided (greater than sixteen [16] sides), and constructed of No. 11 or heavier U.S. standard gauge steel or four inch (4") standard (Schedule 40) pipe or conduit, with the top designed for a post-top slip-fitter. Standard pipe shall conform to the specifications of ASTM A53. The tops of tapered poles shall have a four and one-half inch (4 1/2") outer diameter. Pedestrian pushbutton posts shall be constructed of two and one-half inch (2 1/2") standard (Schedule 40) pipe and meet the requirements of ASTM A53. Multi-sided poles shall not be used without prior approval of the Traffic Engineer.

Poles fifteen feet (15') or longer shall be round or multisided and fabricated from sheet steel of weldable grade.

Poles may be fabricated of full-length sheets or shorter sections. When two pieces are used, the longitudinal welded seams shall be directly opposite one another. When the sections are butt-welded together, the welded seams on adjacent sections shall be placed to form continuous straight seams from base to top of pole.

Poles, prior to installation, shall be straight, with a permissive variation in sweep not to exceed one-quarter inch (1/4") per ten feet (10') of pole length.

A backing plate consisting of a metal sleeve shall be provided at all butt-welded, transverse joints. The sleeve shall be No. 12 U.S. standard gauge steel minimum, and made from steel having the same chemical composition as the steel in the pole.

The metal sleeve shall have a minimum length of three inches (3"). The sleeve shall be centered at the joint and have the same taper as the pole outside the sleeve in full contact with the inside of the standard throughout the sleeve length and circumference. The weld metal at the transverse joint shall extend to the sleeve, making the sleeve an integral part of the joint. In round poles, standard steel pipe or tubing may be substituted for the tapered backing sleeve, at the discretion of the Engineer.

All welds shall be continuous. All welding practices shall conform to current AWS Code, AWS D1.1, latest edition.

All exposed welds, except fillet welds shall be ground flush with the base metal.

All exposed edges of the plates which make up the base assembly shall be finished smooth, and all exposed corners of such plates shall be neatly rounded to one and one-half inch (1 1/2") radius, unless otherwise shown on the Drawings. Anchor holes in the base plate shall be round. Slotted holes shall not be used. Slotted shafts shall be provided with slip-fitter shaft caps of either galvanized steel or cast aluminum.

Non-Destructive Testing (NDT) may be required by the Traffic Engineer on all newly manufactured poles for this project, prior to galvanization. A licensed technician shall perform all testing. NDT shall take the form of Magnetic Particle or Ultrasonic testing, and be performed as described in the current AASHTO standard. If required all NDT reports shall be submitted prior to acceptance for payment.

No exception to the practices mandated by AASHTO shall be allowed.

Poles shall not be relocated or re-used unless Contractor obtains written approval of the Traffic Engineer or designated representative. Damage to the galvanized or painted surface of existing poles to be relocated or reused in place shall be repainted in accordance with Section 80.16, Article 16.3 – Galvanizing or Article 16.4 – Painting for Steel Structures, as appropriate. Holes greater than five-eighths inches (5/8") in diameter in the shafts of existing poles, due to removal of equipment, shall be repaired. Holes shall be repaired by tapping the hole, coating all exposed edges with zinc rich paint, and plugging the hole with a screw-in type steel plug of the correct size. The plug shall be galvanized, or shall be completely covered with zinc rich paint. Holes less than five-eighths inch (5/8") diameter shall be ground smooth so there are no notches or cracks, and coated with zinc rich paint. Plugging holes and repainting damaged galvanized or painted surfaces shall be incidental to other Work.

Extent of additional repairs or replacements will be determined by the Traffic Engineer or designee, and said repairs or replacements ordered will be paid for as extra Work as provided in Division 10, Sections 10.05 – Control of Work and 10.07 – Measurement and Payment.

New steel posts, poles, and mast arms shall be hot-dip galvanized after fabrication in conformance with the ASTM A123. Any damage to the galvanized surfaces that occurs during shipping, or during the construction process, shall be repainted in accordance with Section 80.16, Article 16.3 - Galvanizing or Article 16.4 – Painting for Steel Structures, as appropriate, prior to final acceptance of the poles and mast arms.

All poles and arms shall have permanent identification tags, readily visible, that identify each pole and arm. One tag shall be mounted at the base of the pole shaft and one tag shall be mounted at the base of the mast arm. The tag shall list the following information:

- Pole Number
- Shaft Length
- Mast Arm Length
- Pole Type (SD if applicable)
- Date of Manufacture
- Manufacturer Name.
- Luminaire Arm Length
- Manufacturer Order Number

Article 5.2 Plumbing

Plumbing shall be accomplished by adjusting the nuts on the anchor bolts prior to grouting. A slight raking of the pole will be provided by plumbing the side away from the road. Shims or other similar devices for plumbing or raking will not be permitted.

Article 5.3 Grouting for Slip-Base Poles

The Contractor shall use a premixed grout having a minimum twenty-eight (28) day compressive strength of four thousand pounds per square inch (4000 psi). Proprietary grout mixtures shall be utilized in accordance with the recommendations of the manufacturer.

Concrete areas to be in contact with the grout shall be cleaned of all loose and foreign matter that would in any way prevent bond between the mortar and the concrete surfaces.

Contractor shall not grout unless ambient temperature will remain a minimum temperature of forty-five degrees Fahrenheit (45°F) for three days after grouting. All improperly cured or otherwise defective grout shall be removed and replaced at the Contractor's expense. No load shall be placed on the grout until it has set for at least ninety-six (96) hours.

For concrete bases, after each post, pole or pedestal is in position, grouting conforming to this Article shall be placed under the base plate as shown on the Drawings, and shaped to present a neat appearance.

Article 5.4 Galvanizing

All signal poles, mast arms, and pedestal poles shall be hot dipped galvanized in accordance with Section 80.16, Article 16.3 – Galvanizing.

Article 5.5 Measurement

Fixed-base luminaire poles shall be measured as units complete and in place, including all hardware, all wiring within the poles, and grouting of the base.

Direct-bedded luminaire poles shall be measured as units complete and in place, including all hardware and all wiring within the poles.

Slip base luminaire poles shall be measured as units complete and in place, including slip base adapter, all hardware, and all wiring within the pole.

Signal mast arm poles and signal pedestal poles shall be measured as complete and installed with all hardware, all wiring within the pole, and either grouting of the base or base plate skirt as appropriate.

Combination signal-luminaire poles shall be measured as complete and installed with all hardware, luminaire brackets, all wiring within the pole, and base plate skirt.

Pedestrian push button poles shall be measured as complete and installed with all hardware, all wiring within the pole, and grouting of the base.

All luminaires, luminaire arms, signal heads, pedestrian signal heads, pedestrian pushbutton assemblies, signal mast arms, signs and optical preemption detectors shall be installed and accepted when poles are measured for payment, but shall not be included in payment for poles. These items shall be considered separate pay items, and measured under the appropriate Sections of these Specifications. All other hardware, including wiring within the pole and grouting of the base, shall be considered incidental to the pay items for poles, and shall not be measured for payment.

Article 5.6 Basis of Payment

Payment for this Work shall be in accordance with Division 10, Section 10.07 - Measurement and Payment, and shall include full payment for all Work described in this Section.

Payment shall be made under the following units:

ITEM	UNIT
Ft. Slip Base Luminaire Pole	Each
Ft. Fixed Base Luminaire Pole	Each
Ft. Direct-Bedded Luminaire Pole	Each
Signal Mast Arm Pole	Each
Combination Signal/Luminaire Pole (MTG Height)	Each
Signal Pedestal Pole	Each
Pedestrian Pushbutton Pole	Each

SECTION 80.06 MAST ARMS

Article 6.1 General

Design of signal and luminaire mast arms shall be in accordance with the requirements of the 1994 Edition of the "Standard Specifications for Structural Supports for Highway Signs, Luminaires and Traffic Signals," as published by AASHTO. Minimum design wind velocity shall be the greater of one hundred miles per hour (100 mph) or the AASHTO recommendation based upon a fifty (50) year mean recurrence interval dependent upon project location. A factor of 1.3 shall be used in design calculations to account for wind gusts.

Arms less than fifteen feet (15') in length shall be round or multisided, and constructed of No. 11 or heavier U.S. standard gauge steel, or four inch (4") standard (Schedule 40) pipe or conduit. Standard pipe shall conform to the specifications of ASTM A53.

Arms fifteen feet (15') or longer, shall be round or multisided, and fabricated from sheet steel of weldable grade.

Arms may be fabricated of full-length sheets or shorter sections. Each section shall be fabricated from not more than two (2) pieces of sheet steel for lengths up to forty feet (40'). Where two (2) pieces are used, the longitudinal welded seams shall be directly opposite one another. When the sections are butt-welded together, the welded seams on adjacent sections shall be placed to form continuous straight seams from base end of arm.

A backing plate consisting of a metal sleeve shall be provided at all butt-welded, transverse joints. The sleeve shall be No. 12 U.S. standard gauge steel minimum and made from steel having the same chemical composition as the steel in the pole. The metal sleeve shall have a minimum length of three inches (3"). The sleeve shall be in full contact with the inside of the standard throughout the sleeve length and circumference. The weld metal at the transverse joint shall extend to the sleeve, making the sleeve an integral part of the joint.

Pole plate to pole shaft connection shall be of the "closed box" type with top and bottom plates of the box forming a continuous stiffening ring around the pole. Gusset assemblies for this connection shall be butt-welded together. Vent holes, necessary for galvanizing, shall be used.

All welds shall be continuous. All welding practices shall conform to current AWS Code, AWS D1.1, latest edition.

Non-Destructive Testing (NDT) may be required by the Traffic Engineer on all newly manufactured poles for this project, prior to galvanization. A licensed technician shall perform all testing. NDT shall take the form of Magnetic Particle or Ultrasonic testing, and be performed as described in the current AASHTO standard. If required all NDT reports shall be submitted prior to acceptance for payment.

No exception to the practices mandated by AASHTO shall be allowed.

All exposed welds, except fillet welds and welds on top of mast arms shall be ground flush with the base metal.

All exposed edges of the plates which make up the base of the arm shall be finished smooth and all exposed corners of such plates shall be neatly rounded to one-eighth inch (1/8") radius, unless otherwise shown on the Drawings. Bolt holes in the mast arm base plate shall be round. Slotted holes shall not be allowed. Mast arm ends shall be provided with slip-fitter shaft caps of either galvanized steel or cast aluminum.

Damage to the galvanized or painted surface of existing arms to be relocated or reused in place shall be repainted in accordance with Section 80.16, Article 16.3 – Galvanizing or Article 16.4 – Painting for Steel Structures, as appropriate. Holes greater than three-eighths inch (5/8") in diameter in the shafts of existing arms, due to removal of equipment, shall be repaired. Holes shall be repaired by tapping the hole, coating all exposed edges with zinc rich paint, and plugging the hole with a screw-in type steel plug of the correct size. The plug shall be galvanized, or shall be completely covered with zinc rich paint. Plugging holes and repainting damaged galvanized or painted surfaces shall be incidental to other Work.

Extent of additional repairs or replacements will be determined by the Traffic Engineer or designee, and said repairs or replacements ordered will be paid for as extra Work as provided in Division 10, Sections 10.05 – Control of Work and 10.07 – Measurement and Payment.

Article 6.2 Measurement

Signal and luminaire arms will be measured as units complete and in place, including labor, equipment, and material necessary to make a complete and functioning unit.

All luminaires, signal heads, signs and optical preemption detectors shall be installed and accepted when mast arms are measured for payment, but shall not be included in payment for mast arms. These items shall be considered separate pay items, and measured under the appropriate sections of these Specifications. All other hardware, including wiring within the arms, shall be considered incidental to the pay items for signal mast arms or luminaire arms, and shall not be measured for payment.

Article 6.3 Basis of Payment

Payment for this Work shall be in accordance with Division 10, Section 10.07 - Measurement and Payment, and shall include full payment for all Work described in this Section.

Payment will be made under the following units:

ITEM	UNIT
Signal Mast Arm Ft. Length	Each
Luminaire Arm Ft. Length	Each

SECTION 80.07 CONDUIT

Article 7.1 General

Contractor shall run electrical conductors in conduit, except for overhead wiring, wiring inside poles and when otherwise called for in the Drawings. All conduit and fittings shall be galvanized, rigid type manufactured of mild steel or wrought iron conforming to U.L. Underwriters Laboratory Standard UL-6 and hot dip galvanized in accordance with American National Standards Institute specification ANSI C-80.1. If called for in the Drawings, rigid non-metallic type conduit shall conform to the UL Standard UL-651. Only one type of conduit shall be used in any one run from one junction box to another. Where non-metallic conduit is to be installed, the conduit runs between a load center and the nearest junction box shall be of the rigid metal type.

Conduit and fittings to be installed on the surfaces of poles or in structures and foundations shall be rigid metal type as specified above for underground installations.

Couplings for new rigid metal conduit shall be threaded. Where existing conduit is intercepted and extended, twist-on compression type couplings will be allowed. Set-screw couplings are not allowed on the project.

Conduit in foundations for ground rods shall be one inch (1") diameter.

The ends of all conduits, whether shop or field cut, shall be threaded and reamed to remove burrs and rough edges. Cuts shall be made square and true so that the ends will butt together for the full circumference. Slip joint or running threads will not be permitted for coupling conduit. When a standard coupling cannot be used for coupling metal type conduit, an approved threaded union coupling shall be used. The threads on all ferrous metal conduit shall be painted with rust preventative paint before couplings are made up. All couplings for metal type conduit shall be screwed up until the ends of the conduits are brought together, providing a good electrical connection throughout the entire length of the conduit run. Where the coating on ferrous metal conduit has been damaged, such damaged places shall be painted with rust preventative paint.

Until wiring is started, all conduit ends shall be capped with standard pipe caps or approved plug and coupling combinations. When caps are removed, the threaded ends shall be provided with approved conduit grounding bushings.

Contractor shall lay conduit to a minimum depth of thirty inches (30") below finished grade. See Division 20, Section 20.13 - Trench Excavation and Backfill for backfill requirements.

Clean all debris and moisture out of conduits before installing conductors or cables.

If the conduit is for thaw wire only, then:

Fittings for use in below-grade storm drains shall be suitably rated as NEMA 7, complete with gaskets for watertight installations.

Provide suitable conduit seals and sealant to make connections to junction boxes installed with manholes watertight.

Junction boxes for installation in manholes shall be NEMA Type 7, with gasketed covers for watertight installations.

Couplings and all threaded connections shall be provided with Teflon tape or approved water treatment applied to threads before tightening.

Bottom of trenches for non-metallic conduit shall be relatively free of sharp irregularities which would cause pinching and excessive bending of the conduit. The first six inches (6") of backfill shall be free of rocks exceeding the one inch (1") maximum dimension.

Conduit entering the bottom of concrete junction boxes shall terminate with a ninety degree (90°) sweep inside the box wall. Conduit openings shall terminate not less than five inches (5") above the bottom of all boxes and a minimum of six inches (6") below the top of the Type I and Type IA boxes and twelve inches (12") below the top of Type II and Type III boxes. Conduits entering through the junction box wall shall extend a minimum of two inches (2") inside the box wall, and be a minimum of six inches (6") above the bottom.

All foundations shall be furnished with conduits as shown in the Drawings. The conduits shall extend a maximum of four inches (4") vertically above the foundation and slope towards the hand-hole opening.

Conduit runs shall avoid drainage collection points where possible. At low points in all conduit runs, a one-half inch (1/2") drain hole shall be drilled in the bottom of the lower straight section of the sweep elbow and sump containing approximately two cubic feet of coarse concrete aggregate material shall be installed. Additional drains shall be placed adjacent to all junction boxes and structures, regardless of the method of conduit placement employed. Drilled holes in conduit shall be deburred inside and out to prevent scraping of conductors. The exterior of the one-half inch (1/2") hole shall be wrapped with approved filter cloth material and secured as directed or approved by the Engineer.

Conduits for future use shall be provided with grounding bushings, bonded to ground, and capped with an approved plastic insert type or expandable rubber plug. A polypropylene pull rope with two hundred pound (200 lb) minimum tensile strength shall be installed in all conduits which are to receive future conductors. At least two feet (2') of pull rope shall be doubled back into the conduits at each end.

Contractor shall mark all underground conduits with a continuous strip of 4-mil-thickness, six inch (6") width polyethylene marker tape. Contractor shall mark the tape with a black legend on a red background and buried nine inches plus or minus three inches (9" ± 3") below the finished grade. Contractor shall place two strips of marker tape side-by-side under all road crossings.

Where new junction boxes are placed in existing rigid metal conduit runs, the conduit shall be fitted with threaded bushings and bonded.

Conduit leading to soffit, wall or other lights or fixtures below the grade of the junction box shall be sealed by means of an approved sealing fitting and sealing compound.

Existing underground conduit without conductors to be incorporated into a new system shall be cleaned with a mandrel or cylindrical wire brush and blown out with compressed air.

The Contractor, at his expense, may use conduit of larger size than shown on the Drawings, and where used, it shall be for the entire length of the run from outlet to outlet. Reducing couplings are not permitted.

When extending existing conduits or installing junction boxes in existing conduit runs, extend the conduit into the proposed junction box or foundation using drains, elbows and bonding as required for new installations. When adjusting junction boxes, shorten or lengthen existing conduits to meet clearance requirements. Complete extensions and modifications to existing conduits using the same size and types of materials.

Contractor shall clean all debris and moisture out of conduits before installing conductors or cables.

All abandoned conduits shall be removed from junction boxes.

All knockouts for new conduit or removed conduit shall be grouted.

All knockouts for conduits entering through the side of junction boxes shall be grouted.

Cut off abandoned conduits flush with the inside wall or bottom of junction boxes. Contractor shall remove all conductors prior to abandoning conduit.

Article 7.2 Measurement

Measurement for furnishing and installing conduit is per linear foot of the size and type set forth in the Drawings and Bid Schedule. Measurement is the horizontal distance from center of device to center of device, or from station to station. Measurement shall include all fittings, couplings, pull wires, caps and elbows, and bonding and grounding conductors, which shall be considered incidental to conduit installation.

Conduits installed in manhole and catch basins will not be measured, but rather the following distances will be considered standard unless determined otherwise by the Engineer:

Manhole	forty feet (40')
Catch Basin	sixteen feet (16')

Article 7.3 Basis of Payment

Payment for this Work shall be in accordance with Division 10, Section 10.07 - Measurement and Payment, and shall include full payment for all Work described in this Section. Payment for trench, backfill, and wire are separate bid items.

Payment shall be made under the following units:

ITEM	UNIT
Steel Conduit (Size)	Foot
Schedule 80 PVC Conduit (Size)	Foot

SECTION 80.08 JUNCTION BOXES

Article 8.1 General

The Work under this Section consists of performing all operations pertaining to removing and adjusting existing junction boxes to grade and for furnishing and installing a new junction box of the type specified. This Work shall include all excavation, bedding material, and bonding and grounding hardware.

Type I junction boxes shall not be used in traffic signal systems.

Junction boxes shall be installed at the approximate locations shown on the Drawings. The Contractor, at his expense, may install additional junction boxes to facilitate his Work. Junction boxes shall be located so they are not in the roadway, sidewalk, driveway, or pathway surfaces, unless otherwise noted in the Drawings. Where practical, junction boxes shown in the vicinity of curbs shall be placed adjacent to the back of curb. Junction boxes shall not be located in drainage collection areas.

Article 8.2 Materials

Contractor shall provide precast reinforced concrete boxes (junction boxes) with cast iron lids, of the sizes and details shown on the Drawings.

Contractor shall provide precast reinforced concrete additions (junction box extensions) of the sizes and details shown on the Drawings with dimensions confirmed by field measurements.

Illumination junction boxes shall be pre-cast reinforced concrete with cast iron lids, or polymer concrete boxes of the sizes and details shown on the Drawings.

All Portland concrete cement utilized in the adjustment of the Junction Box shall conform to the requirements as specified in Division 55, Section 55.05 - Manholes and Catch Basin Manholes. The joint sealing compound utilized to seal the joint between the electrical vault's lid and walls shall be Ram-Nek Flexible Plastic Gasket or an approved equal.

Article 8.3 Construction

All junction boxes with metal covers shall have the covers effectively grounded with a four foot (4') tinned copper braid for Type I and Type IA Junction Boxes or a six foot (6') tinned copper braid for Type II and Type III Junction Boxes. Use only stainless steel bolt assembly components to attach bonding braid to the cover (lid). Bond junction box lids to the grounding conductor using copper braid with a cross sectional area equal to an 8 AWG conductor and eyelets spaced at six inch (6") intervals.

The entire bottom of all junction boxes shall be bedded in coarse concrete aggregate material of a minimum depth of eighteen inches (18").

Top of junction boxes shall be one-quarter inch (1/4") below the sidewalk grade or top of adjacent curb. When located in an unpaved section adjacent to a paved shoulder the junction box shall be located one inch (1") below the finished grade and shall be installed one-quarter inch (1/4") below the surface in paved areas. Junction boxes located in areas requiring grading shall be adjusted as directed by the Engineer. Junction boxes located in seeded areas shall be adjusted to two inches (2") below the surface.

Junction boxes shall be located immediately adjacent to the pole or fixture they serve and at additional intervals to reduce the distance between junction boxes to:

1. 400 feet maximum for 25 pair interconnect cable.
2. 200 feet maximum for any other conduit runs.
3. If the limitations require additional junction boxes they shall be located on equal spacings subject to the above limitations.

Emboss the word LIGHTING on the lids of all junction boxes containing only lighting or thaw wire conductors, or only lighting and signal controller power conductors. Emboss the word TRAFFIC on the lid of all other junction boxes.

No later than forty-eight (48) hours prior to commencement of Work on adjustment of the Junction Box, Contractor shall contact the Traffic Department.

Prior to removal of the Junction Box associated with traffic detector loops, Contractor, Engineer, and a Traffic Department representative shall inspect and verify the condition of the Junction Box.

Prior to replacement of the Junction Box, Contractor, Engineer, and a Traffic Department representative shall inspect the vault lid and vault structure to verify adjustments. Any Work, personnel, and/or materials required to properly correct problems shall be at Contractor's expense.

Article 8.2 Measurement

The method of measurement is the actual number of junction boxes removed, adjusted to grade and accepted, and the actual number of new junction boxes of the specified types furnished, installed, and accepted.

The unit cost for adjusting the Junction Box to finish grade shall include all labor, materials, and equipment. This shall include all required usable and unusable excavation, classified fill and backfill material, compaction, concrete cutting and removal, and required personnel.

Article 8.3 Basis of Payment

Payment for this Work shall be in accordance with Division 10, Section 10.07 - Measurement and Payment, and shall include full payment for all Work described in this Section.

Payment shall be made under the following units:

ITEM	UNIT
Junction Box (Type)	Each
Adjust Junction Box to Grade	Each
Remove Junction Box	Each
Junction Box Extension (Type)	Each

SECTION 80.09 EXPANSION FITTINGS

Article 9.1 General

Expansion fittings, as detailed on the structure Drawings, shall be installed where the conduit crosses an expansion joint in the structure. Each expansion fitting shall be provided with a bonding jumper of stranded, No. 6 AWG, copper wire.

Expansion-deflection fittings shall be waterproof and permit a three-quarter inch (3/4") expansion and contraction and a three-quarter inch (3/4") deflection without deformation.

Article 9.2 Measurement

Expansion fittings shall be considered as incidental to other Work.

Article 9.3 Basis of Payment

No separate payment for these items is allowed.

SECTION 80.10 CONDUCTORS

Article 10.1 General

Conductor sizes shall be based on the American Wire Gauge (AWG). Sizes shall conform to the Drawings or, when not shown, to the Conductor Termination Table below. Conductors shall be seven-conductor No. 14 AWG (7C-#14 AWG) for all vehicle heads, and five-conductor No. 14 AWG (5C-#14 AWG) for all pedestrian heads.

Conductor Termination Table

<u>CONDUCTORS/ CABLE</u>	<u>CIRCUIT</u>	<u>WIRE COLOR</u>	<u>AWG NO.</u>	<u>BAND LEGEND</u>
7	Vehicle Red Arrow Vehicle Yellow Arrow Vehicle Green Arrow Common Neutral Spare Spare Spare	Red Orange Green White White/Black Black Blue	14	Head Number
7	Vehicle Red Vehicle Yellow Vehicle Green Common Neutral Spare Vehicle Yellow Arrow Vehicle Green Arrow	Red Orange Green White <i>White/Black</i> Black Blue	14	Head Number(s)
5	Pedestrian Don't Walk Pedestrian Walk Common Neutral Spare Spare	Red Green White Orange Black	14	Head Number
5	Photo Elec. Control <i>PEC</i> Load to Contactor Neutral Spare Spare	Black Red White Orange Green	14	PEC
3	Pedestrian Pushbutton Neutral <i>Spare</i>	Black White <i>Red</i>	14	Head Number Located Under
3	Flashing Beacon Ckt 1 <i>Flashing Beacon Ckt 2</i> Neutral	Black <i>Red</i> White	14	Head Number

Conductor Termination Table

<u>CONDUCTORS/ CABLE</u>	<u>CIRCUIT</u>	<u>WIRE COLOR</u>	<u>AWG NO.</u>	<u>BAND LEGEND</u>
3	Preemption <i>Confirmation Light</i> Neutral <i>Spare</i>	Black White <i>Red</i>	14	“PRE” <i>Conf Lt</i>
3	Highway Luminaire Highway Luminaire Highway Luminaire	Black Red White	8	Circuit Number Circuit Number
3	Service to Controller Neutral Spare	Black White Red	6	“SIG” No Band No Band
3	Sign Luminaire Sign Luminaire Sign Spare	Black Red White	8	SIGN SIGN

All insulated conductors shall consist of uncoated, stranded copper conforming to the specifications of ASTM B8, except for detector loop lead-in which shall consist of stranded, tinned copper.

Grounding conductors shall be bare copper of the gauge required by the Code and may be stranded, solid or braided.

Conductors used for the following purposes shall conform to the referenced specifications.

Article 10.2 Control Cables

Vehicular signal faces, pedestrian signal faces, pedestrian pushbutton detectors, flashing beacons, preemption devices, and photo electric controls shall be wired with signal cable conforming to IMSA 20-1.

The three-conductor No. 20 AWG (3C-#20 AWG) cable shown on the Drawings shall be used in an optically activated preemption system. The cable shall be sheathed in a black PVC jacket and include three (3) No. 20 AWG insulated conductors, and one (1) No. 20 AWG drain wire enclosed within an aluminized polyester shield. All conductors shall be stranded, individually tinned copper. The cable shall contain one yellow, one blue, and one orange insulated conductor. The cable shall be rated for 600 volts operation and be suitable for direct bury, installation in a conduit, and direct exposure to the atmosphere. Cable shall be a Minnesota Mining and Manufacturing 3M No. 138 Opticom cable, or approved equal.

Article 10.3 Power Conductors and Cables

Power conductors and cable shall conform to ICEA Publication No. S-66-524, NEMA Publication No. WC7, and U.L. Standards. Conductors shall be insulated with chemically

cross-linked polyethylene conforming to U.L. type XHHW or XHHW-2. Insulation shall be rated for 600 volt operation.

Three conductor cables shall have black, white, and red colored conductors.

All single-wire conductors and cables shall have clear, distinctive and permanent markings on the outer surface throughout the entire length giving the manufacturer's name or trademark, the insulation type-letter designation, the conductor size, voltage rating and the number of conductors if a cable.

Highway and sign illumination cable shall consist of insulated conductors with a low density, high molecular weight polyethylene jacket.

Power cables with conductors No. 6 AWG and larger shall be PVC or neoprene jacketed.

Load center control circuit wiring shall be No. 12 AWG XHHW.

Conductors in controller cabinets that carry the full signal load circuit shall be No. 10 AWG or larger.

All cabinets shall be wired with conductors sized to handle the amperage drawn under full cabinet use.

Illumination tap conductors that run from the fused disconnect kit in the pole base to the luminaire shall be No. 10 AWG.

Article 10.4 Detector Loops and Lead-In Cables

Conductors for detector inductive loops shall be UL listed as Tube loop detector wire #14 AWG stranded single conductor in PVC tube (IMSA specification 51-5).

Loop Lead-in Cables. Use a tray cable that conforms to the following specifications to connect the loop detectors to the terminal blocks in the controller cabinet. Furnish this cable, also known as Snyder Cable, manufactured according to UL Standard 1277. Third-party certify these cables as Type TC and certified for use in underground conduit or as an aerial cable supported by a messenger, rated for 600 volts AC operation and sunlight resistance.

Use size 18 AWG, sixteen (16) strand, tinned copper conductors per ASTM B-33 insulated with wet rated cross-linked polyethylene. Twist the conductors into seven (7) pairs colored to match the following: Black & Red, Black & White, Black & Green, Black & Brown, Black & Yellow, Black & Orange and Black & Blue.

Provide each twisted pair with an overall aluminum foil coated Mylar shield that provides one hundred percent (100%) coverage and a 20 AWG tinned copper drain that is in constant contact with the foil side of the shield. Apply a tight fitting PVC jacket over the conductor assembly.

Article 10.5 Telemetry Cable

Interconnect cable shall consist of solid copper #19 AWG conductors of the number of pairs called for in the Drawings meeting the requirements of REA specification PE-39 for filled telephone cables. The shield may be either copper or aluminum.

Telemetry interconnect cable shall contain the number of pairs as shown on the Drawings. The conductors shall be covered with a .005-inch copper shield that is electrically intact throughout the entire length of the new circuit. Grounding continuity of all copper shields shall be maintained at all termination points. T-Splices shall be made at the terminal block in the controller cabinet. Configuration and color coding shall be in accordance with the Interconnect Termination Table.

INTERCONNECT TERMINATION TABLE

Telemetry Cable: Type PE-39, #19 AWG, Solid Copper

<u>Pair #</u>	<u>Tip</u>	<u>Ring</u>	<u>Pair #</u>	<u>Tip</u>	<u>Ring</u>
1	White	Blue	14	Black	Brown
2	White	Orange	15	Black	Slate
3	White	Green	16	Yellow	Blue
4	White	Brown	17	Yellow	Orange
5	White	Slate	18	Yellow	Green
6	Red	Blue	19	Yellow	Brown
7	Red	Orange	20	Yellow	Slate
8	Red	Green	21	Violet	Blue
9	Red	Brown	22	Violet	Orange
10	Red	Slate	23	Violet	Green
11	Black	Blue	24	Violet	Brown
12	Black	Orange	25	Violet	Slate
13	Black	Green			

Article 10.6 Measurement

All conductors and cables are measured in linear feet from center of device to center of device, or from station to station. All terminations, markings, slack and other incidental supplies required to meet the provision of the Specifications are not measured, and are considered incidental to the Contract.

Wire and cable within poles, cabinets, and other devices are included under those bid units.

Article 10.7 Basis of Payment

Payment for this Work shall be in accordance with Division 10, Section 10.07 - Measurement and Payment, and shall include full payment for all Work described in this Section.

Payment will be made under the following units:

ITEM	UNIT
(No. of Conductors) (Size of Conductors) (Type of Cable)	Foot

SECTION 80.11 WIRING

Article 11.1 General

Conductors in fixtures and cabinets shall not be spliced and shall be cabled together with self clinching nylon ties. All conductors, including spares shall be attached to terminal blocks with "spade" type terminal lugs.

Conductors shall not be pulled into conduit until junction boxes are set to grade, crushed rock sumps installed, grout placed around the conduit, and rigid metal conduits are bonded to ground.

Conductors shall be pulled by hand or by commercially built cable pulling equipment that is specially designed for that purpose. The cable pulling device shall be equipped with a force limiting circuit and force gauge. The cable-pulling device shall be approved by the Engineer before it is allowed to be used. Powdered soapstone, talc, or other inert lubricant shall be used in placing the cables and conductors in conduit.

When new conductors are to be added to a conduit with existing conductors, all conductors shall be removed and the conduit cleaned with a mandrel or brush. Then both old and new conductors shall be pulled through as a unit. In a new installation, all conductors shall be pulled through the conduit as a unit.

Contractor shall leave at least three feet (3') of slack, but not more than four feet (4'), for each conductor at each lighting and combination pole, and in each junction box, splice location, and controller base. Where lighting conductors are contained in a conduit within the pole, the slack is not required.

Contractor shall install a nylon pull string in all conduits where cable is replaced and/or removed.

The neutral for pedestrian push button circuits shall be separate from the signal light circuit neutral.

All signal conductors shall be run continuously without splices from a terminal block located in a cabinet, compartment, or signal head, to a similarly located terminal block.

Contractor shall splice illumination cable in pole bases and shall use approved fuse kits only. Contractor shall not use wire binding screws, studs or nuts.

With the prior approval of the Engineer, Contractor may use illumination cable splices in junction boxes. Contractor shall join the individual conductors by the use of non-insulated, overlap type pressure connectors insulated with mastic-lined shrink tubing. Contractor shall not use wire binding screws, studs or nuts. Contractor shall stagger splices to minimize overall diameter.

Contractor shall encapsulate illumination cable conductor splices in a rigid, two-piece, transparent, snap together, plastic mold specifically designed for each splice type. Molds shall have dimensions suitable for the splice, encase the cable outer protective jackets, be rated for 600 volts, and have fill and vent funnels for epoxy resin. Contractor shall fill the splice mold bodies, with epoxy resin, that are resistant to weather, aromatic and straight chain solvents, and do not sustain combustion.

Splices shall be insulated by: 1) a heat shrink tubing internally coated with an approved sealing compound or, 2) a cast of self-curing epoxy resin which is compatible with the wire insulation to form a weatherproof joint. Each insulated kit shall encompass only one cable and include the outer protective jacket(s).

Loop lead-in cable shall be run in a continuous manner without splices from the controller cabinet to the curbside detection junction box. Splicing of the loop conductors to the lead-in cable shall be in conformance with Section 80.18, Article 18.1 – Loop Detectors.

When multiple pair loop lead-in cables are specified, each detector loop shall be soldered to an individual shielded pair. Each pair shall then run without splices to the terminal block in the controller assembly, where all series or parallel connections shall be made. At a splice location, a short section of the cable jacket shall be removed and only the shielded pairs dedicated to the loops being spliced shall be cut. Where allowed by the wiring diagram, loops calling different phases shall be connected to separate lead-in cables. The soldered connections shall be insulated with mastic lined heat shrink tubing or two layers of one-half lapped UL listed electrical tape and encapsulated in a waterproof splice kit with re-enterable fill.

Illumination cable conductor splices and lead-in cable splice shall be encapsulated in a rigid, two piece, transparent, snap together, plastic mold specifically designed for each splice type. Molds shall have dimensions suitable for the splice, encase the cable jackets, be rated for 600 volts, and have fill and vent funnels for epoxy resin. The splice mold bodies shall be filled with epoxy resin that is resistant to weather, aromatic and straight chain solvents, and which shall not sustain combustion. Reenterable fill shall be utilized for detector splices.

All cables and single wire conductors shall be permanently identified using labels in all pole bases and cabinets, at each detector loop tail/lead in cable and illumination cable splices and in junction boxes.

Contractor shall furnish the two types of identification tags listed below that require a written legend, and write the legends specified neatly and legibly, using a black marking pen specified by the manufacturer. Contractor shall ensure that legends conform to Section 80.10, Conductor Termination Table, or as shown on the Drawings or detailed in the Special Provisions. Contractor shall replace, at no expense to the Owner, all identifications tags that the Engineer deems are illegible.

1. Use identification cable ties for labeling loop detector tails and for each set of paired loop lead-in conductors in the controller cabinet. Furnish identification

cable ties made of nylon that have a nonmagnetic stainless steel locking device embedded in the head and a tag attached "flag style" to the head. The cable ties shall consist of a single strap with a minimum size tag of three-quarters inch by five-sixteenth inch (3/4" x 5/16").

2. To label all other cables, use cable tags made of nylon reinforced vinyl that is impervious to the elements and will not tear. Provide tags with a four inch by one and three-quarters inch (4" x 1 3/4") minimum size that are attached flag style at one corner to a single strap. Furnish yellow tags for labeling all signal and interconnect cables and red tags for labeling lighting and feeder cables.

Contractor shall remove abandoned conductors/cables.

The control and power cables shall be terminated as shown in 80.10, Conductor Termination Table. Three conductor power cables shall always have a spare. The white or red conductor shall be left as a spare, when the circuit is either 480 volt or a neutral is required, respectively.

Terminate all spare conductors on terminal blocks.

Article 11.2 Measurement

Work performed under this article is considered incidental to other Work.

Removal and disposal of abandoned conductors is not measured for payment and is incidental to other Work. All splices, pull wire-string, cable tags, connectors, and fused disconnects are also considered incidental and no payment shall be made.

The Traffic Signal Electronics personnel will test and perform tie-down for all traffic loop detectors. The Contractor shall prepare the lead-in cables for tie-down, including labeling, insulation stripping and fitting with termination connectors.

When an existing active signal system is being modified, the Traffic Signal Electronics personnel will terminate all control cables within the traffic signal controller cabinet. It shall be the Contractor's responsibility to prepare the cables for termination.

The Traffic Signal Electronics personnel will splice, test and perform tie-down on all interconnect wiring operations.

Article 11.3 Basis of Payment

No separate payment is allowed for this item.

SECTION 80.12 FUSED SPLICE CONNECTORS

Article 12.1 General

A fused, quick disconnect, splice connector shall be installed between the line and luminaire ballast tap conductors in the base of every pole equipped with a luminaire.

The connector shall be weather tight and consist of two halves: a single unit line side socket and load side plug. The plug and socket assembly shall be designed so that the fuse remains in the load side plug without exposing live metal parts when the connector separates. Coil springs shall not be a part of the current carrying circuit.

Contractor shall provide fuses that are ten (10) ampere, midget (13/32" x 1 1/2") ferrule type with a fast acting current limiting (KTK type) design.

The Contractor shall install the fused connectors so they are readily accessible from the handhole. Tap conductors shall be installed so there is no slack when their ends touch the top of the foundation.

Article 12.2 Measurement

Work performed under this article is considered incidental to other Work.

Article 12.3 Basis of Payment

No separate payment is allowed for this item.

SECTION 80.13 BONDING AND GROUNDING

Article 13.1 General

Metallic cable sheaths, metal conduit, non-metallic conduit grounding wire, ballast and transformer cases, service equipment, sign switches, metal poles and pedestals shall be made mechanically and electrically secure to form a continuous system, and shall be grounded. Bonding and grounding jumpers shall be copper wire or copper braid of the same cross-sectional area as No. 8 AWG for all systems.

Bonding of slip-base type standards and pedestals shall be by means of two conductors from the conduit, one attached with a ground rod clamp to an anchor bolt and the other connected to the lower portion of the shaft. Bonding of standards with frangible coupling type bases shall be made by attaching one conductor from the conduit to the lower portion of the shaft. The attaching bolt shall be weather resistant and be a minimum of three-sixteenth inches (3/16") in size. The conductor for the shaft shall be forty-eight inches (48") long.

One side of the secondary circuit of step-down transformers shall be grounded.

Grounding of metal conduit, service equipment and neutral conductor at service point shall be accomplished as required by the Code and the serving utility, except that grounding electrode conductor shall be No. 6 AWG, or equal.

Unless otherwise sized on the Drawings, Contractor shall install a bare #8 AWG copper wire in all non-metallic and metallic type conduits for bonding purposes. When wire is pulled into or out of existing conduit and the conduit does not have an existing bare #8 AWG copper wire, Contractor shall install the ground wire.

Contractor shall install grounded bushings with insulated throats on the ends of all metallic conduits.

Contractor shall splice grounding conductors with irreversible compression type connectors listed for the purpose.

Contractor shall install grounding bushings on all metallic conduits. All non-metallic conduits, except for detector loop home runs, shall have a bushing installed. Contractor shall allow for bushings when installing conduits in foundations.

Contractor shall replace all missing or damaged conduit bonding jumpers and junction box lid braided bonding jumpers.

Contractor shall provide a minimum #10 AWG green grounding insulated conductor in the pole shaft of all poles with luminaires, and shall terminate the conductor in the lighting fixture.

Bond junction box lids to the grounding conductor using copper braid with a cross sectional area equal to an 8 AWG conductor and eyelets spaced at six inch (6") intervals.

An integral bare ground shall not be used in any cable.

Contractor shall ensure that the grounding conductor, between all ground rods, is continuous or spliced with irreversible ground rated splices.

Contractor shall install a three-quarter inch by ten foot (3/4" x 10') copper clad steel ground rod in the foundation space of a two-piece vault style traffic signal controller foundation. If two-piece vault style controller foundation isn't being installed, then install ground rod within Type 3 junction box adjacent to controller cabinet base.

Contractor shall use only stainless steel bolt assembly components to attach bonding braid to the cover (lid).

Furnishing and installing bonding and grounding conductors for electrical installations is incidental to this Contract and no additional payment is made.

Article 13.2 Measurement

Work performed under this article is considered incidental to other Work.

Article 13.3 Basis of Payment

No separate payment is allowed for this item.

SECTION 80.14 LOAD CENTERS

Article 14.1 General

When the positioning of the load center is not detailed on the Drawings, the location shown is approximate and the Contractor shall determine the exact location from the Engineer or the serving utility.

Where Contractor is required to install the service on a utility-owned pole, the positioning of the riser and service equipment is determined by the serving utility.

The serving utility shall approve load center meters, complete with manual circuit closing device and sealing rings. Contractor shall not mount meter sockets on doors.

All accessible sections containing non-metered conductors shall have sealing provisions that will accept Brooks Type 623 seal (0.047 stainless bail).

Contractor shall ensure that the load center is located ten to fifteen feet (10' to 15') from the power source, with a two inch (2") minimum conduit stubbed to within two feet (2') of the power source, and at a minimum depth of forty-two inches (42"). The conduit shall contain a pull-rope, and the end capped and marked with a two by six inch (2" x 6") board. Contractor shall coordinate exact location with the serving utility.

Contractor shall stub service conduit through base as shown on the Drawings.

Prior to the load center being energized by the serving utility, Contractor shall arrange to have it inspected and approved by a Municipal Electrical Inspector. The certificate of electrical inspection, attached to the load center, indicates approval.

At all new and existing load centers, which require modification, the Contractor shall furnish conduit, conductors, contactors, breakers, transformers, and all necessary materials to complete the installation of the service, and upgrade to current code requirements.

Contractor shall label the load center as a unit by an Approved Independent Electrical Testing Laboratory (such as UL, ETL, CSA, etc.) defined by ANSI Standard Publication Z34.1 "Third Party Certification Programs for Products, Processes and Services" and conform to applicable published standards noted herein, the Drawings, and Special Provisions. Contractor shall label the load center as service entrance equipment. All Work shall conform to the latest edition of the National Electric Code as last amended and adopted by the Municipality of Anchorage.

All lighting load centers shall contain a multi-pole, 3-position control switch to provide selection of photocell operation. Contractor shall label switch positions "Auto," "Off" and "On." In the "Off" and "On" positions of the switch, Contractor shall ensure all leads to the photo control device are de-energized. Contractor shall install the switch inside the load center, accessible only through one of the lockable doors.

Contractor shall provide UL-approved and listed circuit breakers. Contractor shall provide an enclosed operating mechanism that is:

1. trip-free from operating handle on overload
2. trip-indicating
3. plainly marked with trip and frame size.

Multiple-pole circuit breakers shall have a common trip. Contractor shall ensure that all circuit breakers are quick-make, quick-break on either automatic or manual operation, and shall meet the requirements of the serving utility. Contractor shall ensure that the contacts are silver alloy enclosed in an arc-quenching chamber. An ambient temperature range of from -40° to +160° Fahrenheit shall not influence overload tripping of breakers.

The contactors shall have contacts rated to switch thirty (30) or sixty (60) AMP inductive loads as the Drawings specify, and are normally open. Contractor shall provide mechanical armature type contactors consisting of an operating coil, a laminated core, a laminated armature, contacts, and terminals with contacts made of fine silver, silver alloy, or superior alternative materials and rated for 480V.

Contractor shall provide the lighting contactor coil(s) rated for operation at 240 VAC.

Contractor shall connect ground bus of load center to ground rod(s) with #6 soft drawn bare copper and approved connectors.

Dimensions given are typical. Slight variations are allowable, subject to Engineer's approval.

Contractor shall submit four (4) copies of manufacturer's shop drawings for Engineer approval.

Contractor shall indicate the interrupting rating on panel schedules for each location.

On panel schedules for each location, Contractor shall indicate service rating of 120/240V, 3 wire; 240/480V, 3 wire; 100 AMP or 200 AMP.

Contractor shall provide a typed circuit directory for each load panel inside of the load center door, protected with a plastic cover, describing each circuit, with even and odd numbered circuit breaker positions shown on separate parts of the directory. Contractor shall provide a power and control 1-line diagram protected by a laminated plastic cover inside the load center. Contractor shall include the following information on the directory and one-line diagram: Load Center Identification (A, B, etc.), Project Name, Municipal Project Number and Service Voltage.

Contractor shall ensure that the wiring configuration conforms to the appropriate electrical diagram, and as the panel schedule indicates for each intersection. Contractor shall

complete a load center summary per appropriate detail drawing for each load center location.

Contractor shall ensure that all terminals are suitable for AL/CU termination, sized in accordance with ampere ratings.

Contractor shall provide #12 AWG XHHW as the load center control wiring.

Contractor shall ensure that the utility section is isolated from main load section and the distribution load sections by non-removable metal barriers, and equipped with landing lugs for utility termination.

The meter section shall contain a meter safety socket with safety shield and provisions for manual bypass of the meter. Contractor shall provide a link or lever type bypass with no external screws, bolts, or nuts. Horn and sliding types are not acceptable.

External screws, bolts, and nuts are not acceptable.

Contractor shall provide exterior nameplate, safety labels, interior identification labels, wiring diagram, and installation instructions with the pad-mounted load centers.

Contractor shall label in a prominent manner all switches and circuit breakers for circuit and direction.

Contractor shall ensure the lighting contactor coil is rated for operation at 240 VAC.

Contractor shall install load centers having 30 milliamp (ma) ground fault circuit breakers with ratings for all heat trace circuits as indicated on the Drawings.

Article 14.2 Illumination Control

Contractor shall install photoelectric controls capable of switching multiple lighting systems directly.

The photoelectric control shall consist of a photoelectric unit that shall cause a contactor to be energized, thus controlling the lighting circuit. Contractor shall install photoelectric units on the load center, unless the Engineer requires pole mounting of the photoelectric unit because a load center mounted unit will not work properly due to ambient light sources. If required, Contractor shall provide photoelectric units for pole top mounting with a slip fitter, terminal block and with cable supports or clamps to support pole wires. There will be no separate payment for providing the required photoelectric units.

Photoelectric Unit:

1. The photoelectric unit shall consist of a light sensitive element connected directly to a normally closed, single pole throw control relay without intermediate amplifications.

2. The unit is either the horizontal sensing or zenith sensing type and shall conform to the following:
 - a. The supply voltage rated is 60 hertz (Hz), 105-277 volts.
 - b. The maximum rated load is a minimum of 1,800 volt-amperes.
 - c. The operating temperature range is from -40°F. to +150°F.
 - d. The power consumption is less than 10 watts.
 - e. The base of the unit has a 3-prong, EEI-NEMA standard, twist-lock plug mounting.
3. Units for highway lighting shall have a "turn-on" between one (1) and five (5) foot candles and a "turn-off" at between one and one-half and five (1½ and 5) times "turn-on."
4. Contractor shall ensure measurements conform to the procedures set forth in EEI-NEMA Standards for Physical and Electrical Interchangeability of Light-Sensitive Control Devices Used in the Control of Roadway Lighting.
5. The photoelectric control unit shall plug into a phenolic resin twist lock receptacle, adjusted to north sky set in a cast aluminum-mounting bracket with a threaded base. When installed on the load center, Contractor shall ensure the bracket is coupled to the end of a rigid metal conduit. When installed on the top of steel poles, Contractor shall ensure the bracket is installed in the center of the rain cap, secured with a locknut and made watertight with a fillet of silicone caulking compound. When installed inside the load center, Contractor shall ensure the installation conforms to the manufacturer's recommendations and that all load center penetrations/openings are silicon sealed.
6. Contractor shall screen photoelectric units to prevent artificial light from causing cycling.

The load center shall contain a 2-pole, 3-position on/off auto switch. In the "on" and "off" positions, Contractor shall ensure the switch interrupts all hot leads to the photocell.

Article 14.3 Step Up/Step Down Transformer

Step up/step down transformers in 480 volt circuits shall be 240-120 volt, 60 Hz type with volt-ampere ratings as shown on the Drawings. Transformers shall carry rated volt-amperes continuously without exceeding 85°C temperature rise above 25°C ambient.

Where installed outside of the load center, use a non-ventilated transformer fabricated of aluminum, stainless steel or galvanized steel. Coat enclosures fabricated of sheet metal with moisture resistant paint.

The case shall be fabricated of aluminum, brass, or galvanized steel. The case shall be coated with moisture resistant paint.

The unit shall be filled with a high melting point insulating compound and shall be hermetically sealed to insure satisfactory operation under continuous submersion in water.

Transformer leads shall be insulated with non-hygroscopic material and shall extend at least nine inches (9") outside the case seal.

The primary and secondary sides of the transformer shall be "protected" in the load center.

Article 14.4 Pad-Mounted Load Center

All doors shall be equipped with continuous stainless steel pin hinges, coin latches, and hasp for padlock.

Meter section door shall have a clear lexan meter reading window, 0.187" minimum thickness, with a minimum size of eight by eight inches (8.0" x 8.0"), and shall include a silicon seal to door.

The load center shall be provided with internal mounting facilities for a one-half inch (1/2") anchor bolt installation as well as for use with a standard factory mounting base assembly.

Construction shall be of zinc-coated A60 finish steel with minimum thickness as follows:

Exterior Shell - 12 GA.

Interior Doors - 14 GA.

Interior Panels - 14 GA.

Interior Covers - 16 GA.

The load center shall be painted with a two-part urethane paint undercoating inside and out. The final finish shall be a two-part urethane paint, standard white for removable panels and non-gloss silver-gray, Benjamin Moore GN-42, for the enclosure.

The required location for the hand-off-auto switch and the contactor is in the distribution load section.

All non-current carrying parts shall be bonded to ground.

Article 14.5 Post-Mounted Load Center, Type 2 - Underground Service

A post-mounted load center, Type 2, shall be defined in the Construction Drawings by reference to appropriate Standard Details for the load center, wiring diagram, and panel schedule.

Article 14.6 Post-Mounted Load Center, Type 3 - Overhead Service

A post-mounted load center with overhead service, Type 3, shall be defined in the Construction Drawings by reference to appropriate Standard Details for the load center, wiring diagram, and panel schedule.

Article 14.7 Single-Meter Pad-Mount Load Center, Type 1 & 1A

A single-meter pad-mount load center, Type 1A, shall be similar to Circle AW CMP-4111MN mounted on MB-1514 base or equivalent approved by the Municipal Traffic Engineer. It shall be defined in the Construction Drawings by reference to appropriate Standard Details for the load center, wiring diagram, and panel schedule.

A single-meter pad-mount load center, Type 1, shall be similar to Circle AW CMP-4900 series mounted on MB-2820 base or equivalent approved by the Municipal Traffic Engineer. It shall be defined in the Construction Drawings by reference to appropriate Standard Details for the load center, wiring diagram, and panel schedule.

Article 14.8 Measurement

Load centers shall be measured as units, complete and in place. Bases for pad-mounted load centers shall be a separate bid item under "foundations."

Photoelectric units mounted on the load center shall not be measured separately for payment. The Work performed under Article 14.2 – Illumination Control, is considered incidental to Work performed under Articles 14.5 through 14.7, unless a pole mounted photoelectric unit is required.

Article 14.9 Basis of Payment

Payment for this Work shall be in accordance with Division 10, Section 10.07 - Measurement and Payment, and shall include full payment for all Work described in this Section.

Separate payment will be allowed for pad-mount bases.

Payment shall be made under the following units:

ITEM	UNIT
Post-Mounted Load Center Overhead Service, Type 3	Each
Post-Mounted Load Center Underground Service, Type 2	Each
Single-Meter Pad-Mount Load Center, Type 1	Each
Single-Meter Pad-Mount Load Center, Type 1A	Each
Pole-Mounted Photocell Installation, Complete	Each
120/240 - 240/480, Transformer	Each

SECTION 80.15 WOOD POLES

Article 15.1 General

Wood poles for service or temporary installations shall be of the class shown on the Drawings. Wood poles used in temporary installations shall meet or exceed ANSI class 4 for poles used for temporary illumination only, and ANSI class 1 for poles used for temporary signalization.

Poles shall not have more than 180 degrees twist in grain over the full length. Sweep shall be no more than four inches (4"). Poles shall be placed in the ground to a depth of at least six feet (6'). The lengths of poles shall be twenty-five feet (25') for service poles and thirty-five (35') feet for other poles, unless otherwise specified.

After each wood pole is set in the ground, the space around the pole shall be backfilled with selected earth or sand, free of rocks four inches (4") or larger, or deleterious material, placed in layers approximately four inches (4") thick and thoroughly compacted with mechanical tampers.

Mast arms and tie rods for wood pole installations shall conform to the provisions of Section 80.05 – Poles, Steel Pedestals, and Posts, and to the details shown on the Drawings. Each mast arm shall be provided with an insulated wire inlet and wood pole mounting bracket for mast arm and tie rod cross arm.

Overhead equipment shall provide a minimum vertical clearance of eighteen feet (18') from bottom of equipment to the pavement.

Wood poles, not to be painted, shall be pressure treated after fabrication with creosote, pentachlorophenol (oil borne), or copper naphthenate (oil borne) in accordance with the latest applicable standards of the American Wood Preservers Association. Where it is impractical to obtain the specified retentions because of the character of the wood in the charge, the treatment shall be to refusal. The retentions may be determined either by gauge or scale readings or by assay. Treated poles shall be coated in conformance with current EPA regulations.

Wood poles shall not be used for permanent installations.

Article 15.2 Measurement

Wood poles used for temporary support of signals, signs and illumination shall be measured as temporary wood pole structures installed and removed.

Article 15.3 Basis of Payment

Payment for this Work shall be in accordance with Division 10, Section 10.07 - Measurement and Payment, and shall include full payment for all Work described in this Section.

Payment shall be made under the following units:

ITEM	UNIT
Temporary Wood Pole Structures	Each

SECTION 80.16 MISCELLANEOUS

Article 16.1 Sign Switches

Each sign illumination installation shall be provided with a disconnect switch mounted on the sign standard or structure, as shown on the Drawings. Where the sign lighting is served from a multiple service, each sign structure shall have a 120-volt, 240-volt, or 480-volt circuit breaker, approved by UL as service equipment, and rated as shown on the Drawings.

Enclosures for the sign breaker shall be galvanized or baked enamel NEMA Type 3R, and shall be provided with top hinged cover, hasp for sealing cover and provisions for locking.

Article 16.2 Field Tests

Prior to acceptance of the Work, the Contractor shall perform the following tests on all traffic signal, sign illumination, and lighting circuits, in the presence of the Engineer.

A. Tests

Any fault in any material or in any part of the installation revealed by these tests shall be replaced or repaired by the Contractor at his expense in an approved manner, and the same test shall be repeated until no fault appears.

1. Continuity

Each circuit shall be tested for continuity.

2. Grounds

The test for grounds in each circuit shall consist of the physical examination of the installation to insure that all required grounding bushings, bonding jumpers, and ground rods have been installed and are mechanically firm.

3. Insulation

A megohm test shall be made on each circuit, between circuits and between the circuit and a ground. The insulation resistance shall not be less than 100 megohms or the minimum specified by the manufacturer, measured at 500 volts direct current (VDC). All lamps and magnetometer sensing probes shall be disconnected prior to performing the megger test.

4. Circuit

Every signal indication circuit shall be energized with lamps installed prior to installation of the load switches.

5. Functional

The following tests shall be performed on each signal and lighting system after all of the component circuits have satisfactorily passed the tests for continuity, grounding, insulation integrity and circuitry.

B. Functional Testing

During the test periods, the Contractor will maintain the system or systems. The cost of any maintenance necessary, except electrical energy, shall be at the Contractor's expense.

1. The functional test for each new or modified traffic signal system shall consist of not less than twenty-four (24) hours nor more than five (5) days of continuous flashing operation.
2. During the functional tests, signals shall not be switched from flashing operation to normal, continuous operation on a Saturday, Sunday, Monday, a Holiday, or the day after a Holiday.
4. The functional test for each highway lighting system and sign illumination system shall consist of an operational test for five (5) consecutive nights according to the regular lighting schedule.
5. The functional test for each flashing beacon system shall consist of not less than five (5) days of continuous, satisfactory operation.
6. A continuous five (5) day burning test shall be made on each pedestrian overcrossing and undercrossing lighting system before final acceptance.

The initial turn-on shall be made between 9:00 a.m. and 2:00 p.m. unless specified otherwise in the Special Provisions. Prior to turn-on, all equipment shown on the Drawings shall be installed and operable. This includes, but is not limited to, pedestrian signals and push buttons, signal face backplates and visors, vehicle detectors, highway lighting and all regulatory, warning and guide signs. All signal faces shall be aimed as required by Sections 80.19 – Signal Heads and 80.20 – Pedestrian Signals.

Article 16.3 Galvanizing

Standards, pedestals, posts and cabinets of ferrous materials shall be galvanized in accordance with the provisions of ASTM A123 except that cabinets and cut out boxes may be constructed of material galvanized prior to fabrication.

Iron or steel pipe standards and mast arms shall be hot-dip galvanized after fabrication in conformance with the ASTM A123.

Tie-rods, nuts, washers, clamps, anchor bolts and other miscellaneous ferrous parts shall be hot-dip galvanized after fabrication in accordance with the provisions of ASTM A153. Anchor bolts shall be fully galvanized.

After galvanizing, the bolt threads shall accept galvanized standard nuts without requiring tools or causing removal of protective coatings.

Rigid metal conduit shall be hot dip galvanized in accordance with American National Standards Institute specification ANSI C-80.1.

Galvanized coatings that have been cut or damaged shall be repaired in conformance with ASTM A780.

Article 16.4 Painting for Steel Structures

A. General Requirements. Ship paint in strong, substantial containers, plainly marked with the name, weight, and volume of the paint content, together with the color formula, batch number, and the name and address of the manufacturer.

Reduction and clean-up thinners will be as approved by the coating manufacturer. Ship all thinners in the manufacturer's original containers.

B. The paint shall conform to the requirements outlined below:

1. Prime Coat. A generic single component, moisture cure, polyurethane (SC-MC-U) containing not less than 78% by weight zinc powder. Volume of solids shall be 60% minimum. Pigment type shall be zinc dust. Zinc in dry film shall be 83% minimum, by weight. Weight per liter shall be 2750 g, minimum. Volatile organic compounds (VOC's) shall not exceed 450 g/L.

2. Intermediate Coat. A SC-MC-U containing not less than 480 g/L micaceous iron oxide (MIO). Volume of solids shall be 60% minimum. Pigment color shall contrast between the intermediate and prime coat and the intermediate and top coat. Weight per liter shall be 1550 g minimum. VOC's shall not exceed 450 g/L.

3. Top Coat. A single component, moisture cure, aliphatic polyurethane (SC-MC-ALIP-U), containing not less than 480 g/l micaceous iron oxide (MIO). Volume of solids shall be 60% minimum. Pigment color of the top coat shall be FSS FED-STD-595B, color number 26492. The color match shall be evaluated as a general match under a daylight source using ASTM D 1729. Weight per liter shall be 1550 g minimum. VOC's shall be less than 450 g/L.

3. All coatings shall pass the following tests:

a. Corrosion Resistance, ASTM B 117, Salt Spray Test. Minimum of 4000 hours with less than 2 mm creep from scribe. Panels shall be 3

mm minimum thickness cold rolled steel, having SSPC Near White Blast with 25 to 50 μ m angular profile.

- b. Accelerated Weathering, ASTM G 53. Minimum 400 hours QUV B bulb with no chalking, cracking, or gloss loss greater than 20%.
- c. Forward Impact, ASTM D 2794. Minimum 17 Nm impact.
- d. Abrasion Resistance, ASTM D 4060. Less than 90 mm loss on CS-17 wheel, 1000 g/load, 1000 cycles.
- e. Moisture Resistance, ASTM D 4585. Minimum 1000 hours at 38° C with no change in appearance.
- f. Flexibility, ASTM D 522, Cylindrical Mandrel Bend Test. Bend around 12.5 mm diameter mandrel with no cracking.
- g. Adhesion, ASTM D 4541. Minimum 3.5 Mpa on a certified pull test.

C. New Equipment.

- 1. Signal heads, signal head mountings, brackets and fittings, outside of visors, pedestrian push button housings, pedestrian signal head housings and visors, and back faces of backplates, shall be factory finished with two (2) coats of dark olive green enamel. Painting is not required where the color is an integral part of the component material, or powder coated.
- 2. Interior of signal visors, louvers, and front faces of backplates shall be factory finished with two (2) coats of lusterless black enamel.
- 3. After erection, all exterior surfaces shall be examined for damage, and such damaged surfaces shall be cleaned and spot coated with primer and finish coat.
- 4. Two factory finishing coats of aluminum paint shall be applied to controller cabinets.
- 5. Controller cabinet shall be painted white inside and silver-gray outside, with under coating inside and out.

D. Reused Equipment.

- 1. Existing non-galvanized, damaged equipment shall be painted in the field, including Owner-furnished equipment. The equipment shall be washed with a stiff bristle brush using a solution of water containing two tablespoons (2 tbs/gal) of heavy duty detergent powder per gallon. After rinsing, all surfaces shall be wire brushed to remove all poorly bonded paint, rust, scale,

corrosion, grease or dirt. Any dust or residue remaining after wire brushing shall also be removed prior to priming.

2. Factory or shop cleaning methods for metals will be acceptable if equal to the methods specified herein.
3. Immediately after cleaning, all bare metal shall be coated with Pre-Treatment, Vinyl Wash Primer, followed by two (2) prime coats of Zinc Chromate Primer for Metal.
4. Signal equipment, excluding standards, shall be given a spot finishing coat on newly primed areas, followed by one (1) finishing coat over the entire surface.
5. Ungalvanized standards shall be given two (2) spot finish coats on newly-primed areas.
6. All paint coats may be applied either by hand brushing or by approved spraying machines. The Work shall be done in a neat and workmanlike manner. The Engineer reserves the right to require the use of brushes for the application of paint, should the Work done by the paint spraying machine prove unsatisfactory or objectionable.

Galvanized equipment with rusted areas shall be repaired as provided for in Article 16.3 - Galvanizing.

Article 16.5 Measurement

The Work performed under this section is considered incidental to other Work.

Article 16.6 Basis of Payment

No separate payment is allowed for Work performed under this Section.

SECTION 80.17 CONTROLLER ASSEMBLIES

Article 17.1 General

Each solid-state, traffic controller assembly shall operate various traffic signal devices as shown on the Drawings, to provide right-of-way, clearance and other indications with duration and sequence as determined by preset programming.

Details of operation for the complete controller assembly shall be in accordance with the traffic phases, preferential phase sequence and concurrence, signal indications, signal indication sequence, detection requirements and other details shown on the Drawings or as specified herein.

All controller assemblies shall conform to the requirements of NEMA STANDARDS PUBLICATION/No. TS-1-1989 unless otherwise specified. All Load Switches, Flashers and Flash Transfer Relays shall conform to the requirements of NEMA STANDARDS PUBLICATION/No. TS-2-1998.

Indicators for all electronic devices covered under this Section shall be of the non-incandescent type.

All controllers must be compatible with the existing Anchorage traffic control systems and contain necessary internal communication modems. In the Central Business District (CBD), six-phase dual ring NEMA controllers will be used. Outside the CBD, fully actuated eight-phase dual ring NEMA controllers will be used. Separate controller phases for each movement provide timing flexibility although the displayed phases to the driver may appear to be less than eight.

Article 17.2 Controller Unit

Controller units shall conform to NEMA STANDARDS for microprocessor-based, solid state, digital timed, eight-phase traffic actuated signal controller providing up to eight phases of signal control, internal preemption, time base coordination, internal time-of-day programming, and data base management by an IBM PC.

The signal controller shall be constructed in accordance with the requirements of NEMA *Publication No. TS1-1989*, unless otherwise noted. The Contractor shall submit documentation with his bid detailing the brand and model number of the signal controller proposed to be furnished. This documentation shall include catalog cuts, operational details and NEMA certification reports. The agency reserves the right to reject any and all equipment that does not meet these Specifications.

Since controller interchangeability at the connector level is foremost in these specifications, the NEMA pin assignments for connectors A, B, and C shall not be modified or changed in any manner. External features beyond NEMA shall be provided on a fourth connector; PROVIDED, however, that all logic signals shall be low state (nominal 0 volts)

for the True (operate) state. Each pin in every connecting cable shall be terminated on a separate terminal and be accessible for troubleshooting or employment of special features

The traffic signal controller shall be solid state, modular by function, microprocessor based, eight-phase device. Each NEMA connector (A, B, and C) shall be mounted on individual modules and shall be configured so that it is possible to remove them to reconfigure the eight-phase unit into a two-, four- or six-phase controller. No other modifications to the controller shall be required to reconfigure the controller as a two- or four-phase unit.

The controller shall be capable of being configured for either single or dual ring operation with phases occurring in any order in either ring. Phases in the same timing ring shall not time concurrently. Phases not in the same timing ring may time concurrently, provided they are on the same side of the barrier or compatibility line.

All cabinet control equipment shall be designed to operate under the following physical conditions:

- An ambient temperature range of -30° to +165° Fahrenheit.
- A relative humidity range of 5%-95% (without condensation).
- A voltage range of 95 to 135 VAC RMS with a corresponding frequency range of 57-63 HZ.

The design life of all components shall not be less than five (5) years of continuous twenty-four (24) hour operation.

All printed circuit boards shall be conformal coated after assembly.

The controller shall have all sixteen (16) or more pin integrated circuit components socket mounted.

The design of the controller shall incorporate a mother board design with all functional modules plugging into the mother board assembly. All modules shall be equipped with connectors which prevent the module being inserted upside down. The motherboard shall be completely removable without desoldering or disconnecting individual wires.

All printed circuit modules shall be aligned with printed circuit card guides and held firmly in place by a captive screw or other locking device when installed in the controller.

The entire controller unit shall be designed so as to permit complete disassembly of the unit. No welds, pop rivets, or other permanent fasteners may be employed which would preclude complete disassembly.

The controller power supply shall be removable as a unit and shall be plug connected. Removal shall not require the disconnection of individual wires.

The design of the controller shall incorporate the use of non-volatile electrically erasable read-only memory (EEPROM) for the storage of timing and operating parameters. The controller data base shall not require battery and the only allowed use of a battery is to power the backup clock during power outages.

All components on the module circuit boards shall be easily accessible and shall be arranged in a functional grouping. Printed circuit boards shall have the following minimum quality requirements:

1. Boards shall be NEMA Grade A, G10 Glass Cloth Base Epoxy Resin with a minimum thickness of one-sixteenth inch (1/16").
2. Intercomponents wiring shall be copper track with a minimum weight of two ounces per square foot and have adequate cross-section of the current being carried by each circuit. All components mounting holes and circuit pass-through holes shall be plated through.
3. Printed circuit design shall be such that components may be removed and repaired without permanent damage to the printed circuit board when proper soldering techniques are used.
4. All components on each printed circuit board shall be permanently identified on the circuit side of the board.

The controller shall be completely enclosed in a protective case with a durable paint finish.

All front panel indicators on the controller shall have minimum design life of 5,000 hours at their normal operating voltage level. Front panel indicators of the controller shall be automatically extinguished after a one-hour period of non-use of the keyboard.

- A. The following features shall be provided as part of the controller software, and as such shall be available for operator selection from the front panel keyboard:
1. Conditional service.
 2. MUTCD flash.
 3. Time-of-day clock.
 4. Sequence control.
 5. Programmable overlaps.
 - a. Standard NEMA overlaps.
 - b. Protected/permissive overlaps.
 - c. Negative overlaps.
 - d. Auxiliary timed overlaps.
 6. Programmable start-up sequence.

7. Simultaneous gap-out.
8. Internal coordination including:
 - a. Time base coordination.
 - b. External system coordination.
 - c. "ON LINE" command from central computer.
 - d. Designated master output functions.
 - e. Critical intersection card (DSA).
9. Full or semi-actuated coordination.
10. Dual entry by phase.
11. Soft recall selectable by phase.
12. Alternate phase sequences.
13. Programmable dimming by phase and color.
14. Traffic counting capability for 16 detector channels.
15. Internal emergency vehicle preemption:
 - a. High priority vehicle.
 - b. Low priority vehicle.
16. Secondary coordinated phase assignment.

B. It shall be possible to observe and adjust the controller operation via the front panel while the intersection is in full operation and without placing the intersection in flash. The front panel keyboard, through which all instructions to controller memory shall pass, shall be of "scratch pad" type, making it necessary to depress an ENTER key before any stored programs are altered. A display shall be provided, showing that the data has been edited, validated, and accepted into operating memory. Additional displays shall be provided for all vehicle and pedestrian calls such that they may be viewed simultaneously with displays for phase timing intervals of both timing rings of the controller. Phase timing interval displays shall show a countdown time remaining in the active interval of each ring simultaneously with phase data. Displays provided for phase configuration and timing data shall be alphanumeric displays using mnemonic designations readily understood by traffic engineering personnel.

The controller shall provide the standard NEMA eight phase dual ring sequence and, in addition, allow the selection of the following alternate sequences:

1. Quad sequential.
2. 8-phase sequential.
3. Exclusive phase 1 or exclusive phase 2.

4. Dual 4-phase without barrier restraints.
5. Phases 1 & 6 and 3 & 8 do not time concurrently.

Each phase shall be separately programmable to provide the following functions:

1. Locking and non-locking vehicle detector memory.
2. Vehicle recall to minimum green.
3. Soft recall to minimum green (selected phases recalled only in the absence of other serviceable calls).
4. Vehicle recall to maximum green.
5. Pedestrian recall.

The time interval setting per phase shall provide, as a minimum, the following increments and ranges, each in seconds:

<u>FUNCTION</u>	<u>RANGE</u>	<u>INCREMENT</u>
Minimum Green (initial)	0-255 seconds	1 second
Walk	0-255 seconds	1 second
Pedestrian Clearance	0-255 seconds	1 second
Passage Time (Gap)	0-25.5 seconds	0.1 second
Maximum Green #1	0-255 seconds	1 second
Maximum Green #2	0-255 seconds	1 second
Yellow Clearance	3-25.5 seconds	0.1 second
All Red Clearance	0-25.5 seconds	0.1 second
Red Revert	2-25.5 seconds	0.1 second
Actuations B4 Added Initial	0-255 actuation	1 actuation
Seconds Per Actuation	0-9.9 second/actuation	0.1 second
Time Before Reduction	0-255 seconds	1 second
Time to Reduce	1-60 seconds	1 second
Minimum Gap	0-8.0 seconds	0.1 second
Conditional Minimum Green	0-255 seconds	1 second

The front panel displays for each ring shall include, as a minimum, the following:

1. Phase(s) timing.
2. Interval(s) timing countdown.

3. Phase(s) next.
4. Vehicle calls.
5. Pedestrian calls.
6. Reason for phase termination.

The controller shall be capable of resting in "all red" in any phase in the absence of vehicle or pedestrian calls. This feature shall be internal time-of-day selection.

The controller shall be equipped with a separate time interval setting for "Red Revert" which shall provide a minimum period that any phase must display red prior to returning to a green display of the same phase. The increments for this setting shall be one-tenth (1/10) second and the range shall be two to twenty-five (2-25) seconds selectable for each phase independently.

C. Conditional service, when enabled, causes the following controller operation: If two even numbered concurrent phases are timing and a call exists on the other side of the barrier, and one of the phases is prepared to terminate due to gap out or max time out, the ring containing the timed out phase shall revert to its preceding off numbered vehicle phase if:

1. A call exists on that odd numbered phase.
2. There is sufficient time remaining before the max time of the concurrent even numbered phase has elapsed.

The criteria for determining if sufficient time remains for conditional servicing is, if the clearance time plus the conditional service minimum green time is less than the time remaining on the max timer of the even numbered phase timing concurrently.

Conditional service applies to vehicle phases only. For phases with concurrent pedestrian service, the pedestrian display will remain Don't Walk. Any pedestrian calls placed prior to reservice or during the reservice will be stored until the phase is serviced normally.

If a conditionally serviced phase has been reserviced, the ring containing that phase will not return to the even numbered phase but will remain in the conditionally serviced phase until the complimentary ring's even numbered phase has gapped out or reached its max time and the minimum conditional service time, then the controller shall revert to its normal phase sequence operation.

The gap times of the conditionally served phase does not extend the green time of that phase when it is being reserviced.

Conditional service shall be selectable manually from the front panel by use of the keyboard or by the internal time-of-day program.

- D. The controller software shall be capable of providing MUTCD flash control. This control shall consist of selectable main street green phases and function as follows:
1. Upon the receipt of the flash command, the controller shall continue normal operation until the next All Red interval in the sequence.
 2. At the conclusion of the All Red interval the intersection shall be placed in flashing operation and the controller held at the beginning of Main Street Green until the flash command is removed.
 3. The controller program shall have a minimum flash time to protect against short flashing operation. This minimum flash time shall be programmable from 0 to 255 minutes in one minute increments.
 4. The return from programmed flash shall be at the beginning of the selected Main Street Green intervals.
 5. Programmed flash shall be capable by remote input to the controller or by the internal time-of-day program.
- E. The controller software shall contain a complete time-of-day program supported by a real time clock. The real time clock shall use the 60 Hz power line frequency as a time base and, in the absence of line power, use a battery supported clock, to maintain accurate time during power failures of up to six months. The real time clock shall incorporate automatic leap year correction, and provide an optional automatic daylight savings time correction.

The time-of-day program shall provide for a minimum of 48 separate programs with each program capable of multiple use on individual days, combination of days, or one time events. Time-of-day commands shall be executed with a one minute resolution, and the program shall be capable of looking back and selecting the correct program following power outage or controller startup.

Each time-of-day program shall provide for control of the following functions:

1. Flash ON/OFF (MUTCD).
2. Omit All Red by phase.
3. Call to Semi-actuated operation.
4. Min Recall by phase.
5. Max Recall by phase.
6. Ped Recall by phase.
7. Conditional Service ON/OFF.
8. Phase rotation.
9. Density by phase.

10. Coordinated or Free Operation.
 11. Coordination Parameters (Cycle, Split, Offset).
 12. Phase omit/Ped omit by phase.
 13. Red Rest by phase.
 14. Max II by phase.
 15. Special Functions ON/OFF.
 16. Enable detector sampling reports.
 17. Enable dynamic split allocation (CIC operation).
- F. The controller shall have a selectable feature commonly known as "Simultaneous Gap-Out", which requires both concurrently timed phases to reach a rest state (by having gapped out) simultaneously before they terminate their Green display and advance across a barrier. Selection of this option shall allow a phase to retime the gap interval from a Green Rest state upon vehicle actuation.
- G. The controller shall provide for overlap programming by a NEMA Overlap Card, as required by the NEMA standards and, in addition, shall have the option of programming from the front panel keyboard.

Standard overlap programming shall allow the inclusion of any of the eight (8) NEMA phases and provide the proper control of the four (4) sets of NEMA Red, Yellow and Green overlap outputs.

In addition to standard overlaps, the controller shall provide additional overlap features as follows:

1. Protected/permissive overlaps.
 2. Right turn overlap w/special sequencing.
 3. Auxiliary timing for overlaps including:
 - a. Auxiliary overlap Green (0 to 255 sec.).
 - b. Auxiliary overlap Yellow (3 to 25.5 sec.).
 - c. Auxiliary overlap Red clearance (0 to 25.5 sec.).
- H. It shall be possible to change the NEMA phase sequencing by reversing the order of any two (2) sequential phases which are in the same ring and on the same side of the barrier. This phase-rotation feature shall be accessible through the special function module and the 4th connector assembly. They shall also be selectable by the internal time-of-day program or by the internal coordination program.

- I. An internal software coordination package shall be included in the controller which shall have the following features:
 1. Six cycle lengths (30 to 255 seconds in one-second steps).
 2. Five offsets per cycle length (30-255 seconds in one-second steps).
 3. Separate vehicle and pedestrian permissive periods for each phase. Permissive periods shall be automatically calculated by the controller using the split settings and the minimum vehicle and pedestrian timings for each phase.
 4. Selectable semi-actuated or fully actuated coordinated operation.
 5. Selectable free or coordinated operation.
 6. An ON-LINE input from a remote master. The ON-LINE command from a remote central computer shall inhibit the internal coordination program and allow the controller to respond immediately to the central computer or remote master commands. Upon loss of on-line the controller shall revert to time-base coordination.

The coordination package shall be capable of short route transitioning to get in synch or change timing Drawings. Programmable shrinkage or expansion of each cycle length shall be able to be set from the front panel. During transition no clearance interval shall be changed nor any minimum green time violated.

The coordination shall work with the internal time-of-day program and provide time-of-day selection of the following operational parameters:

1. Coordinate/Free.
2. Semi Actuated Coordination.
3. Fully Actuated Coordination.
4. Cycle Length (1 to 6).
5. Split (1 to 3).
6. Offset (1 to 5).
7. Phase Sequence (0 to 15).
8. Coordinated Phases by cycle.
9. Dynamic Split Allocation (CIC control).

From the front panel it shall be possible to read and load all programmable coordinated functions. All coordinated displays shall be in alphanumeric displays using mnemonic designations readily understood by traffic engineering personnel, e.g., CYL = Cycle, SPL = Split, YLD = Yield.

With the controller running in the coordinated mode it shall be possible to use the front panel displays to observe the coordination program in effect. As a minimum, it shall be possible for the operator to observe the following functions on a continuous basis:

1. Cycle in effect.
2. Offset in effect.
3. Split in effect.
4. Type of coordination.
5. Countup of cycle-in-effect from master zero.
6. Countup of cycle-in-effect from local zero.
7. Force offs by phase.
8. Vehicle permissive period by phase.
9. Pedestrian permissive period by phase.
10. Synch pulse (System zero).
11. Synch pulse (Local zero).

The software shall make validity checks on all phase timing and coordination data being entered by the user before accepting the data into permanent memory, e.g., summation of splits per ring equal the cycle length or split value is greater than minimum phase timing.

If the validity checks detect data error, the operator shall be notified of the cause of the error by an indication on the front panel displays.

During coordination operation a time-of-day option shall be available to enable the dynamic split allocation (CIC control). This feature will automatically increase or decrease the split values, on a cycle by cycle basis, as indicated by traffic data obtained from the phase detectors.

The internal coordination software shall provide a front panel programmable method of adjusting the operational offset value by field observation during active operation.

- J. It shall be possible to program one railroad priority control sequence and four completely independent priority vehicle sequences. Railroad preemption shall have priority over vehicle preemption. Each vehicle preemption shall consist of two state i.e. high priority and low priority. A high priority command shall terminate a low priority command. The internal priority control shall provide outputs for programmable displays to indicate priority operation.
- K. The controller program shall contain an optional start-up all red interval. Upon completion of the powerup flash interval, or the application of the NEMA startup

command, the controller shall time a programmable ALL RED interval before beginning operation in the start-up phases. This interval shall be programmable from 0 to 255 seconds in one second increments.

- L. The controller program shall provide for the selection of startup in selected phase(s) Green, Yellow, or ALL RED intervals.
- M. A special function (4th connector) cable shall provide eight (8) auxiliary detector inputs. These eight (8) detectors may be used as traffic count stations, system sampling stations or assigned to the NEMA phases. They may also be used to obtain one minute average speed data of traffic over the detectors.

When assigned as a NEMA phase input, each detector shall have provision for the following operation:

- 1. Delay time before call (0-255 seconds in 1 second increments).
- 2. Extension time of call (0-25.5 seconds in 0.1 second increments).
- 3. Disconnect mode selection:
 - Type 1: Disconnect during parent phase Green after first call.
 - Type 2: Disconnect when unoccupied for extension time.
 - Type 3: Combination of Type 1 and Type 2.
 - Type 4: Detector switching; after termination of the protected turn phase, turn phase detectors are switched to extend the permissive concurrent thru phase.
 - Type 5: Detector switching; turn phase detectors call the concurrent thru phase until the left turn phase is active.
- N. Intersection status and traffic count information shall be accumulated for 72 count periods detailing the volume and occupancy data from the eight (8) NEMA detector inputs and the eight (8) Auxiliary detector inputs. The accumulation period shall be adjustable from 1 to 255 minutes in one-minute increments, and may be enabled or disabled by the internal time-of-day program.

The report shall be accessed through the RS-232C port of the controller and may be printed using a serial dot-matrix printer or transmitted to a remote master for viewing on a CRT.

- O. An event log shall be available, internal to the controller software which will record and log the exact minute specific operational events occur. The log will show the number of events, the first time the even occurred and the last time the event occurred. Keyboard entry shall be provided for the operator to view the log and to reset the log to "0" after inquiry. Provisions shall be made to log the following events:
1. Internal clock updates.
 2. Communication error.
 3. Conflict status.
 4. Flash Status.
 5. Diagnostic test failure.
 6. Cycle monitor test.
 7. Controller access.
 8. Short power loss (less than 0.5 sec.).
 9. Long power loss (greater than 0.5 sec.).
- P. The controller shall be furnished with a RS-232C communication interface port to allow the remote access of the complete controller data base with a serial printer, portable programmer and/or system modem. A DB25 female connector shall be provided for this function. The entire data base, including traffic count information, coordination parameters, all preemption intervals and all NEMA timing intervals shall be accessible through the RS-232C communication port.
- Q. The controller shall be capable of optional self-diagnostic tests while in the normal run operation. These automatic tests shall consist of diagnostics to check the CPU, RAM, EEPROM and PROM memory of the controller, shall be halted, the intersection placed in flashing operation using the NEMA voltage monitor output, and a failure message shall be displayed on the front panel.

Article 17.3 Standard Auxiliary Equipment

Load Switches, Flashers and Flash Transfer Relays shall conform to the requirements of NEMA Standards Publication No. TS-2-1998.

Conflict Monitors shall conform to the requirements of NEMA Standards Publication No. TS-1-1989, unless otherwise specified.

The following auxiliary equipment shall be furnished and installed:

- A. Flasher: Flasher shall be NEMA Type III.
- B. Load Switches: Load switches shall be supplied with an LED (light emitting diode) circuit indicator.

C. Flash Transfer Relay: Flash transfer relays shall be plastic encapsulated 30 amp, 120 volt. The relays shall transfer the signal light circuits from controller unit to the flasher.

D. Conflict Monitors:

1. Conflict monitors shall meet or exceed NEMA specifications. They shall be microprocessor based with NVRAM memory, switch selectable options, liquid crystal display and an RS-232 serial port that allows the monitor to download information through an external dial-up multi-port modem or to a personal computer using the Microsoft Windows NT operating system.. Each monitored input and each fail mode shall be displayed as a separate indication.

Faults and histories shall be recorded in Non-Volatile Random Access Memory (NVRAM) and be viewable via the front panel display and retrievable via the RS-232 communications connector.

Internal logic shall be such that should an error occur all active inputs at the time of the error and the fail mode type shall be illuminated. The indications shall remain illuminated until the unit is manually reset.

2. The Contractor shall not install any device to the input of the unit that would inhibit the unit from sensing a high impedance load or loss of load.
3. The unit shall monitor each yellow signal display for a minimum display period of three (3) seconds. A yellow less than three (3) seconds shall energize a fault circuit and place the intersection in emergency flash.
4. The unit shall provide switch selectable options to allow for dual indication monitoring with a channel or phase. When selected, the monitor shall detect as a conflict the following combinations:
 - a. Green or walk and yellow
 - b. Green or walk or yellow and red.
 - c. Either of 2 or 3 of the above
5. The unit shall have a switch selectable option allowing for the modification of the NEMA red failure error. When selected, the WALK input shall not be considered in the RED FAILURE logic.
6. The unit shall have an internal "watchdog" circuit to test continually for unit failure. In the event of unit failure, the unit shall cause the intersection to enter the flash mode of operation. Monitor failure must be indicated.
7. The unit shall test for proper operation of its memory devices. The memory test must occur at least at power-up and reset. If memory failure occurs, the

unit will cause the intersection to enter flash mode and indicate monitor failure.

- E. Communications: Contractor shall provide and install one Actelis Intelligent Transportation Systems model ML688 with 4x10/100M copper Ethernet ports and a 100Base-FX optical SFP port or equivalent in each controller assembly. All equivalent substitutions shall be submitted to the Traffic Engineer for testing and approval prior to installation.

Article 17.4 Special Auxiliary Equipment

The following special auxiliary equipment shall be furnished and installed:

- A. Inductive Loop Detectors. Inductive loop detectors shall conform to the following:
 - 1. All "P" and "R" controller cabinets shall be wired to accommodate five 4-channel inductive loop detector units and two 2-channel inductive loop detector units, wired per the latest controller assembly wiring diagram available from the Traffic Signal Electronics Shop Foreman. All "M" or other sized cabinets shall be wired in accordance with the latest controller assembly wiring diagram available from the Traffic Signal Electronics Shop Foreman.
 - 2. The detector unit shall be an electronic device capable of providing closure of an output circuit when a vehicle stands or passes over a loop or one (1) of several loops connected to the input circuitry of the sensor control unit. The output shall be electrically isolated from the loop and the electronic circuitry.
 - 3. Performance Characteristics. The detector shall operate with the specified configurations of loops and leadwire, including series and parallel combinations, having a total inductance of not less than forty-five (45) microhenries, nor more than one thousand (1,000) microhenries. Each detector channel shall provide continued operation with a loop shorted to ground and place a continuous call in the event of an open loop or a failed power supply.
 - a. The detector shall "rephase" (resume detection of vehicles on unused portions of the loop) after a vehicle has parked over the loop for a pre-selected time. This is usually referred to as "presence time." Presence time shall be selected by a front panel switch. For determining presence times, a test loop of 120 microhenry inductance, having a minimum area of ninety (90) square feet and a 750 foot lead-in shall be used. Number 14 PVC with nylon jacketed loop wire shall be used for the loop. Either No. 12 AWG or No. 18 AWG instrumentation cable shall be used for the lead-in. The detector shall be operated continuously on the test loop for a

minimum of ten (10) minutes before measuring presence time. With a loop and lead inductance shift of five percent (5%), long presence time shall be longer than ten (10) minutes, medium presence time shall be longer than three (3) minutes, and short presence time shall be less than one (1) minute. Short presence time shall have a pulse output of 100+50 milliseconds. Sensitivity shall not be affected by changing the presence time.

- b. Sensitivity measurements shall be made on a loop configuration as defined in the preceding paragraph. The detector shall provide reliable detection of all vehicles when the inductance shift of the loop, caused by the vehicle's presence, is two-hundredth percent (0.02%) of the total inductance of the loop and leadlines. In the normal sensitivity mode, an inductance shift of one-tenth percent (0.1%) shall provide reliable detection. Count accuracy shall be better than ninety-nine percent (99%) of all vehicles passing over the loops at speeds of zero miles per hour (0 mph) to speeds greater than eighty miles per hour (80 mph).
- c. There shall be no false detections when the detector is subjected to power line transients in accordance with NEMA Standard TS-1. Sections 2, 7 & 11 Test Procedures. The detector shall withstand the discharge of a two (2 MFD) capacitor charged to one thousand (1000) volts directly across the loop input lines or from either loop input line to chassis. An open loop circuit shall provide a constant vehicle call output.
- d. Multiple channel units shall scan loop input circuits to eliminate cross-talk and have frequency switch to reduce cross-talk between units.
- e. *Single channel and two channel units shall have a Delay-Call feature provided.* This feature shall delay the detector call output for an adjustable zero to thirty (0-30) seconds. The associated green phase (120 VAC) shall be monitored and inhibit the delay times, thus causing no time delay between the sensing and outputting of the vehicle call.
- f. *Single channel and two channel units shall have an Extension feature provided.* The detector units shall, upon actuation, be capable of timing the delay setting and then immediately begin timing the extension setting without interruption. Upon expiration of the extension timing due to gaps between vehicles, the unit shall again begin timing the delay setting with the next vehicle actuation. This shall be accomplished without the use of any external circuitry. The detector units shall be Detector System, Inc., Model 921-2T, or

approved equal meeting the other applicable requirements of these Specifications.

4. Control Unit Construction

- a. The control unit shall contain an integral power supply which shall operate from a fused one hundred twenty (120) VAC-60Hz source. Fuse capacity shall be identified adjacent to fuse holder on the front panel.
- b. Circuit design shall be all solid state digital except for the output which will be provided by means of a plug-in relay. The relay shall have isolated normally open (N.O.) and normally closed (N.C.) contacts capable of switching all loads in the range from two (2) MA at eighteen (18) VDC to at least three (3) AMPS at one hundred thirty-five (135) VAC. In case of power failure, either internal or external to the detector unit, the relay shall provide a constant detection signal.
- c. The input/output connector(s) shall be of the Military Specification (MS) type and conform to the following pin configurations:

(1) Single Channel Detector Unit

MS 3102A-19-1P Connector

<u>Pin</u>	<u>Standard Function</u>	<u>Delay Function</u>
A	AC Neutral	AC Neutral
B	Relay (Arm)	Relay (Arm)
C	AC Line	AC Line
D	Loop Input	Loop Input
E	Loop Input	Loop Input
F	Relay (N.O.)	Relay (N.O.)
G	Relay (N.C.)	Relay (N.C.)
H	Chassis Ground	Chassis Ground
I	Not Used	Not Used
J	Not Used	Phase Green (120 VAC)

(2) Two Channel Detector Unit

Two MA 3102A-18-1P Connectors

Each channel utilizes the same pin configuration and functions listed in Section 660-3.04, c(3)(a).

(3) Four Channel Detector Unit

MS 3106A-22-14P Connector

<u>Pin</u>	
A	AC Neutral
B	Channel 4 Relay (Arm)
C	AC Line
D	Channel 1 Loop Input
E	Channel 1 Loop Input
F	Channel 2 Loop Input
G	Channel 2 Loop Input
H	Chassis Ground
J	Channel 3 Loop Input
K	Channel 3 Loop Input
L	Channel 4 Loop Input
M	Channel 4 Loop Input
N	Channel 1 Relay (N.C.)
P	Channel 1 Relay (Arm)
R	Channel 2 Relay (N.C.)
S	Channel 2 Relay (Arm)
T	Channel 3 Relay (N.C.)
U	Channel 3 Relay (Arm)
V	Channel 4 Relay (N.C.)

The operation of the control unit shall not be affected by changes in the inductance of the loop caused by environmental changes. The operating temperature range of the control unit shall be -35°F to +165°F, with the rate of temperature change not exceeding 1°F per three (3) minutes. The unit shall operate within all limitations of this specification. The control unit shall be capable of tracking loop inductance shift of ten percent (10%) with no loss of sensitivity. An "off" switch shall be capable of blocking loop detection. All relays and large scale integrated circuits (LSI's) shall be socket mounted.

Each control unit shall be housed in a metal case. Control units may be furnished with either an integral power supply or

a separate power supply common to more than one (1) sensor unit.

B. Preemption Equipment

All preemption equipment shall be 3M Company Opticom Control System equipment or equivalent. All emergency preemption communication equipment shall be Actelis Intelligent Transportation Systems equipment or equivalent. All equivalent substitutions shall be submitted to the Traffic Engineer for testing and approval prior to installation.

During signal preemption, the controller unit rather than the phase selector or auxiliary logic shall perform all interval timings, signal sequences, and phase skips.

The controller assembly shall be furnished with:

1. Two (2) Model 754 Phase Selectors (one for emergency backup), except that Model 752 Phase Selector may be used for 2-Phase operations when shown on the Drawings.
2. One Model 760 Card Rack.
3. One Opticom Panel Assembly, U.S. Traffic Corporation part number 103303 or approved equal, which interfaces the card rack to the controller cabinet.
4. One model ML688 with 4x10/100M copper Ethernet ports and a 100Base-FX optical SFP port.

The Model 760 card rack and Opticom Panel Assembly shall be wired in accordance with the latest controller assembly wiring diagram available from the Traffic Signal Electronics Shop Foreman.

C. Traffic Logging Equipment

With each controller assembly containing detector amplifiers, a Detector System Inc. "Traffic Logging System" TLS-1-C1 harness and Model TLS-1 unit shall be provided.

A 120 VAC receptacle shall be provided on the left-hand side of the cabinet.

D. Radar Detectors

Radar detectors shall not be used unless approved by the Traffic Engineer.

Any substitutions of cable, material or equipment must be submitted to the Traffic Engineer for testing and approval prior to installation.

At the locations shown on the Drawings, install sensors that operate in the X-band radar frequency and use microprocessor analyzed Doppler-microwave detection method for detecting vehicles moving toward or away from the unit. Furnish sensor units that:

1. Shall be installed in accordance with the manufacturers written installation instructions.
2. Shall be Microwave Sensors Model TC26B sensors that operate in the X-band radar frequency and use microprocessor analyzed Doppler-microwave detection method for detecting vehicles moving toward or away from the unit.
3. Install a sixty-hertz (60-hz) transformer with one-hundred-twenty-volt (120V) AC primary and twenty-four-volt (24V) AC secondary in the controller cabinet. Follow the manufacturer's requirements for current output per detector. Furnish a UL-listed, class two (2) rated transformer with built-in overload and short circuit protection.
4. A fuse block shall be provided with four (4) fuses to protect the twenty-four-volt (24V) AC transformer secondary and isolation relay from damage due to faults outside of the controller cabinet assembly.
5. For each detector, a socket mounted isolation relay shall be provided for the controller cabinet assembly. The relay shall be an RH1B-UAC24V with snap mount socket and aluminum din rail. One leg of the relay coil shall connect to the twenty-four-volt (24V) AC transformer secondary while the other leg shall be fused and connected to the detector unit relay.

E. Ultrasonic Presence Sensors

Ultrasonic presence sensors shall not be used unless approved by the Traffic Engineer.

Any requests for substitutions of cable, material or equipment must be submitted to the Traffic Engineer for testing and approval prior to installation.

Ultrasonic presence sensors shall be Microwave Sensors Model TC30C.

At the locations shown on the Drawings, install sensors that operate at an ultrasonic frequency and sample for the presence of stationary and moving vehicles at a rate of ten times per second. Furnish sensor units that:

1. Feature solid-state circuitry and a high-speed transducer with the sensitivity to detect motorcycles. The cone of coverage produced by the transducer should measure at least four (4) feet in diameter at least twenty-one and one-half (21.5) feet from the transducer. The unit shall provide a continuous

call to the controller unit with the presence of a vehicle in its cone of coverage and whenever the unit loses power.

2. Include an external control to adjust the length of the cone of coverage, an external detection light emitting diode, and mounting brackets suitable to install the units on traffic signal pole mast arms.
3. Require no external amplifiers, seasonal tuning, or special cabling, and operate at all temperatures from -31°F to 167°F (-35°C to 75°C). Wire each sensor using two (2) pairs of our six-pair loop lead-in cable.
4. Operate on a voltage of twelve (12) to twenty-four (24) volts AC. Install a sixty-hertz (60 hz), forty (40) volt-ampere transformer with 120-volt AC primary and 24-volt AC secondary in the controller cabinet. Furnish a UL-listed, Class 2 rated, transformer with built in overload and short circuit protection.

F. External Special Logic circuits shall not normally be used.

Article 17.5 Controller Cabinet

A. The Contractor shall supply the following standard features:

1. Cabinet Construction

Each controller unit and all auxiliary equipment shall be housed in a weatherproof, aluminum or steel, approved metal cabinet(s).

The cabinet shall have a main door equipped with a construction core lock. The lock shall be capable of accepting a Best CX series core that will be installed by the Municipality after completion of the Contract. It shall have an auxiliary door equipped with lock and police key. The door hinge pin shall be continuous and made of stainless steel material. Two (2) keys shall be furnished for each lock. The police key shall have a shaft at least one and three-quarters inches (1 3/4") in length.

Each controller cabinet door which is twenty-two inches (22"), or larger, in width or six (6) square feet, or larger, in area shall be provided with a stop to limit door opening to both ninety (90) and one hundred eighty (180) degrees, plus or minus ten (10) degrees. The stop shall be provided with a catch which can be operated when the door reaches the extreme open position and will hold the door open securely until released.

Substantial metal shelves or brackets shall be provided to support controller unit and auxiliary equipment.

Machine screws and bolts shall not protrude beyond the outside wall of the cabinet.

2. Cabinet Ventilation

Each controller cabinet shall be provided with louvered vents with a permanent metal mesh air filter held firmly in place, which will permit the fan to pass the volume of air specified.

Each controller cabinet shall be equipped with an electric fan with ball or roller bearings and a capacity of at least one hundred (100) cubic feet per minute. The fan shall be mounted near the top of the controller cabinet.

The fan shall be thermostatically controlled and shall be manually adjustable to turn on between 90°F. and 150°F. with a differential of not more than 10°F. between automatic turnon and turnoff. The cabinet fan circuit shall be fused at one hundred twenty-five percent (125%) of the ampacity of the fan motor installed.

The fan and cabinet vent shall be located with respect to each other to direct the bulk of the air flow over the controller unit or through the ventilating holes of the controller unit where such holes exist.

The fan and cabinet vent shall be furnished with internally mounted, metal covers, fabricated to close off the flow of air during winter operation.

The cabinet shall be equipped with a selectable, 750/1500 watt cabinet heating device. The heating device shall be equipped with a remote air sensing thermostat. The contacts shall be rated twenty (20) amps, one hundred twenty (120) volts. The thermostat shall be constructed so that contacts close on descending temperature, adjustable between 0°F and 30°F±5°F. The contacts shall open on rising temperature at 15°F above closing temperature. The adjustment shall have an indicating pointer. The thermostat shall be connected in series with an electrical resistance heater and blower fan. The blower fan shall be rated for continuous duty. The heater and fan shall be connected in parallel and rated one hundred twenty (120) volts, sixty (60) hertz. The unit shall be mounted as shown on the latest controller assembly layout diagram available from the Traffic Signal Electronics Shop Foreman. Care shall be taken not to block the air intake or outlet. The unit shall be provided with an SPST manual override switch which shall bypass the thermostat enabling the fan and heater to operate at warmer temperatures.

3. Cabinet Wiring

Wiring within controller cabinets shall be neatly arranged and conform to the requirements of Sections 80.10 through 80.13.

Wiring shall be color coded as follows:

For DC voltages:

Logic Ground	Gray
+24VDC	Red with White tracer

For AC voltages:

AC+	Black
AC-	White
AC Chassis Ground	Green

Load switch wiring shall be color coded as follows:

Vehicle Load Switch	Red	Red
Vehicle Load Switch	Yellow	Yellow
Vehicle Load Switch	Green	Green
Pedestrian Load Switch	Don't Walk	Orange
Pedestrian Load Switch	Walk	Blue
Transfer Relay	Brown	

All wiring, switches, surge protectors, flash relays, flashers, etc., shall be sized to handle the necessary amperage required under full cabinet use.

Intersection flash operation shall be programmable by rearranging interconnecting jumpers between the load switches, flash transfer relays and field signal wire terminal blocks. Changes shall be accomplished by moving the jumpers at the terminal blocks.

Each standard function of the controller unit shall be brought to an external terminal through the regular controller connector and wiring harness. Logic ground shall not be connected to AC neutral.

Calling detector operation, when called for on the Drawings or in the Special Provisions, shall be accomplished by connecting the detector amplifier relay to parent phase red drive circuit, without the use of external logic cards or relays.

Terminals and Terminal Blocks

- a. Two (2) or more insulated terminal blocks shall be provided for terminating field conductors. Each block shall be provided with twelve (12) poles with 10-32 screw type terminals and 10-32x3/8" screws. The terminal block shall be a barrier type with removable shorting bars in each of the twelve (12) positions and with integral type marking strips. All conductors shall be terminated to a terminal block.

- b. All terminal blocks shall be provided with nickel, silver, or cadmium plated brass binder head screw terminals.
- c. Conductors from the controller unit shall terminate in "ring" type terminal lugs or shall be soldered to a through panel solder lug on the rear side of the terminal. All other conductors shall terminate in "spade" type terminal lugs.
- d. Terminal blocks rated 1,000 volts, RMS maximum, twenty (20) amperes, may be provided for connecting cables from the controller unit and conductors from the external solid-state logic circuits. Conductors shall be secured to the terminal blocks with 6-32x1/4 inch binder head screws.
- e. No more than three (3) conductors shall be brought to any one (1) terminal. Two (2) flat metal jumpers, straight or U-shaped, may also be placed under a terminal screw. At least two (2) full threads of all terminal screws shall be fully engaged when the screw is tightened. No live parts shall extend beyond the barrier.
- f. Field terminals shall be installed on a channel support running from one side of the door opening to the other. Terminals shall be under the front edge of the shelves and shall be oriented for screwdriver operation straight in from the door opening. Terminals shall be a minimum of six inches (6") above the foundation.
- g. A Type 66 B3-50 terminal block shall be installed for telemetry cable terminations.
- h. The right hand side of the cabinet shall have a sixteen (16) position neutral buss bar and a sixteen (16) position ground buss bar. The left-hand side of the cabinet shall have a thirty-two (32) position neutral buss bar and a thirty-two (32) position ground buss bar.

All controller cabinets shall be wired to handle the full capacity of the controller unit specified on the Drawings (6 or 8 phase).

4. Cabinet Accessories

a. Circuit Breakers

- (1) Control circuit breakers shall be fifty (50) ampere rating for eight- (8-) phase cabinets or thirty (30) ampere rating for six- (6-) phase cabinets.
- (2) Auxiliary circuit breakers shall be rated at twenty (20) amperes. One breaker shall provide protection for fan, light

and ground fault interruptor (GFI) convenience outlet. One breaker shall provide protection for the heater.

b. Radio Interference and Transient Suppressors

Each traffic controller unit, flasher, and other current interrupting device shall be equipped with a suitable metal oxide varistor in advance of a suitable radio interference suppressor installed at the input power point. Interference suppressors shall be of a design which will minimize interference in both broadcast and aircraft frequencies, and shall provide a minimum attenuation of fifty (50) decibels over a frequency range of two hundred (200) kilohertz to seventy-five (75) megahertz when used in connection with normal installations. The interference suppressor shall be hermetically sealed in a substantial metal case filled with a suitable insulating compound. Terminals shall be nickel-plated, 10-24 brass studs of sufficient external length to provide space for connecting two (2) No. 8 AWG conductors, and shall be so mounted that the terminals cannot be turned in the case. Ungrounded terminals shall be properly insulated from each other, and shall maintain a surface leakage distance of not less than one-quarter (1/4") inch between any exposed current conductor and any other metallic part, with an insulation factor of 100-200 megohms dependent on external circuit conditions. Suppressors shall be designed for one hundred twenty-five percent (125%) of the total connected load and in no event less than twenty-five (25) amperes, one hundred twenty (120) volts, sixty (60) Hz, single-wire circuits, and shall meet standards of the UL and the EIA.

c. Surge Protection

The power supply to the controller shall have transient voltage protection conforming to the following minimum requirements:

A Gas Tube, TII-317B or approved equivalent, shall be installed on the load side of the main circuit breaker immediately before the radio interference suppressor (RIS) filter.

A Metal Oxide Varistor, shall be connected to the load side of the RIS filter.

The transient voltage suppressor shall be a solid-state high energy circuit, containing no spark gap, gas tube, or bar component. The protection provided shall be a transient suppression of 200 volt peak, a transient response of less than five (5) nanoseconds, a power dissipation of 10,000 watts.

The protector shall function with a 10 x 1000 microsecond waveform clamping no greater than 200 volts peak. Transient voltage surge suppressor (TVSS) self sacrifice shall be indicated by an external lamp, but the load shall not be disconnected from the AC power.

d. Light Fixture

Light fixture. The cabinet light fixture shall be an incandescent type porcelain lamp holder rated for 660W-250V AC/CA. The lamp shall be 110W.

e. Control Panel

A control panel assembly, readily accessible from the front of the cabinet, shall be provided and labeled. The control panel assembly shall consist of:

- (1) A "Controller Power" switch shall be provided to energize the controller while the signal lights are off or being operated by the flasher. The switch shall be labeled and rated for load current.
- (2) A convenience outlet shall be provided. The convenience outlet shall be a three- (3-) wire, twenty (20) ampere, one hundred twenty (120) VAC plug receptacle, in duplex configuration, with ground fault protection.
- (3) A "Signal-Flash" switch which, when placed in the "Flash" position, shall provide flashing operation, without interrupting controller unit power. When said switch is placed in the "Signal" position, the controller unit shall provide normal operation.
- (4) A "Stop-Time" switch which, when placed in the on position, will cause the controller unit to stop time. In the "Off" position, the controller unit shall continue normal timing regardless of external commands. In the "Auto" position, timing shall be normal, but subject to external command interruptions.
- (5) A "Heater Bypass" switch shall be connected to bypass the remote heater thermostat.
- (6) A "Cabinet Light" on-off switch. (A door activated switch shall also turn off the light when the door is closed.)

- (7) Momentary contact test switches shall be provided to place calls on each vehicle and pedestrian phase. Switches shall provide tactile feedback and shall be rated at one ampere, minimum, for a resistive load at one hundred twenty (120) volts AC and at twenty-eight (28) volts DC. Contacts shall be coin silver or gold plated, and shall be enclosed and labeled as to their function.
- (8) "REM/TOD/FREE" switch: In "REM" position will cause the local TOD and CRD to follow instructions of the remote master. In "TOD" position will allow the local TOD to operate independent and the local CRD to follow the local TOD instructions. In "FREE" position the local CRD shall have no effect on the local controller operation and the local TOD shall not be affected.
- (9) "Force-Off" switch: A "Force-Off" switch shall be provided for each 'Ring.' The switches shall be the momentary contact type, provide tactile feedback and shall be rated at one (1) ampere minimum for a resistive load at one hundred twenty (120) volts AC and at twenty-eight (28) volts DC. Contacts shall be coin silver or gold plated, and shall be enclosed and labeled as to their function.

f. Police Panel Assembly

A labeled police panel assembly, located behind the auxiliary door, shall be provided. The police panel assembly shall consist of:

- (1) A "Flash-Automatic" switch which, when placed in the "Flash" position, shall cause the intersection displays to go into the flashing mode. When placed in the "Automatic" position, it shall cause the signal system to resume normal operation.
- (2) A "Signal ON/OFF" switch which, when placed in the "OFF" position shall remove AC power from the load switches and disable control, by any means, of the Flash Transfer Relays. The cabinet shall not be allowed to output AC power to any external device.
- (3) A removable, rigid metal cover shall be provided on the back of the police panel to cover the live switch terminals.

g. The cabinet shall contain a conspicuous warning sign against operation without the conflict monitoring device being installed.

Article 17.6 Operation

Unless otherwise shown on the Drawings, the following operations shall be provided:

- A. The controller cabinet shall be wired to flash the yellow signals on the main street or highway and the red signals on the cross streets and left turn lanes.
- B. The flashing circuit shall be independent on the controller unit and shall remain in operation upon shutdown of the controller or removal of the controller from the cabinet.
- C. The controller cabinet shall be wired so that removal of the conflict monitor shall cause the intersection to go into flashing operation.
- D. Transfer to flashing operation shall be accomplished by relays between the normal load switching device and the field terminals.
- E. Pedestrian pushbuttons shall not be operated at more than 24 volts.
- F. Controller Priorities. The drives, controls and equipment shall have priorities and each device, control or item of equipment shall override the operation of those items listed below it:
 - 1. Power failure
 - 2. Power restart
 - 3. Flashing
 - 4. Railroad preemptor
 - 5. Emergency vehicle preemptor
 - 6. Phase selector
 - 7. Interconnect
 - 8. Time switch
 - 9. Normal controller unit operation

Article 17.7 Shop Tests

Traffic controller cabinet, cabinet wiring diagrams, controller units, and auxiliary equipment shall be shipped to the Traffic Signal Electronics Lab at 3650 East Tudor Road, Building C. The Traffic Signal Electronics personnel will inspect cabinet wiring, burn in signal cabinet equipment, customize cabinets(s) for desired operation and test in accordance with the following specifications.

The Contractor shall allow six (6) weeks to allow for shop testing. All required equipment including wiring diagrams shall arrive in one shipment. Partial shipments will not be accepted and will be returned to the vendor.

Traffic signal equipment shall meet the operational and functional requirements of the Drawings and Specifications when tested in accordance with NEMA Standards Publication Number TS-1-1989, Traffic Control Systems.

If a partial failure occurs at any step in the test - physical, environmental, or operational - the Contractor will be permitted to make on-the-site repairs within ten (10) days after notification of the malfunction. The test will then be restarted at beginning of category in which malfunction occurred. Failure to make repairs in ten (10) days after notification will result in rejection.

If equipment malfunctions twice in the same category, the equipment will be rejected. When equipment is rejected, the entire package, including cabinet, will be returned freight collect to the vendor. New equipment, with a different serial number, must then be submitted for testing. Rejected equipment shall not be used on signal projects within the Municipality.

Testing subsequent to rejection of the equipment for failure to comply with specification requirements will be at the expense of the Contractor. Deductions to cover the costs of such testing will be made from any monies due or which may come due the Contractor under this Contract.

A failure shall be defined as any occurrence which results in other than normal operation of the equipment. The equipment is considered to have failed if any of the following occur:

1. The controller unit malfunctions.
2. The load switch produces incorrect signal indications.
3. The signal conflict monitor fails to satisfy the requirements of the Contract Specifications.

After satisfactory completion of the shop test, the Contractor will be notified to pick up the tested and marked equipment at the test site. The Contractor shall pick up successfully tested equipment within two (2) weeks of notification. The Contractor shall deliver said equipment to the Work site. Successful completion of the test does not relieve the Contractor of equipment warranty obligations as specified in Section 80.01, Article 1.4 – Warranties, Guarantees, and Instruction Sheets, or field testing as specified in Section 80.16, Article 16.2 – Field Tests.

Copies of the shop test results will be sent to the Contractor and associated vendor.

Article 17.8 Installation

- A. Typically, cabinets shall be positioned so that the corner formed by the cabinet back and the side wall, to which the door hinge is attached, is the nearest point of the cabinet to the center of the intersection. Cabinet positioning shall be subject to the review and acceptance of the Traffic Signal Electronics Foreman.

- B. Where the cabinet is mounted on a concrete pedestal foundation, a one inch (1") drain hole or pipe, with screen, shall be placed in the foundation, connecting to the cabinet and emptying above the ground line.
- C. A three-eighths inch (3/8") fillet of silicone caulking shall be placed between each controller cabinet and the concrete slab foundation to prevent dust and dirt from entering the cabinet.
- D. When called for in the Drawings or Special Provisions, two inches (2") of approved foam insulation shall be added within the bottom of the cabinet, between the control equipment and the concrete base. All wiring, terminals, and other items shall be designed to allow sufficient room for the insulation.
- E. On Precast Controller Foundations. When called for in the Drawings or Special Provisions, a three-eighths inch (3/8") thick, two- (2-) piece exterior grade plywood board shall be placed on the bottom of the cabinet and under the foam insulation. Holes shall be made to allow for the conduits entering the cabinet. A pliable sealant composed of silicone caulking compound shall be placed between the plywood board and the cabinet and between the plywood board and all the conduits.

Article 17.9 Measurement

Traffic signal controllers will be measured as units, complete and in place, including labor, cabinet, hardware, controller unit, standard and auxiliary equipment, all as required by this Section and by the Contract Drawings Special Provisions to provide a complete and working system.

Article 17.10 Basis of Payment

Payment for this Work shall be in accordance with Division 10, Section 10.07 - Measurement and Payment, and shall include full payment for all Work described in this Section.

Payment will be made under the following units:

ITEM	UNIT
Six-Phase Controller Unit	Each
Eight-Phase Controller Unit	Each

SECTION 80.18 VEHICLE DETECTORS

Article 18.1 Loop Detectors

For the purpose of this Section, the "home run" and the "home run loop wires" are defined as the pair of wires from the loop in the traveled lane to the nearest junction box. The "lead-in" or "lead-in cable" is defined as the shielded twisted pair cable from the junction box to the controller cabinet.

All connections between the loop wire and shielded lead-in cable shall be made as follows:

- A. Shielded lead-in cable pairs shall not be cut except when they are to be spliced to a loop and then only at the junction box where the splice shall be made. Used and unused ends of the cut pairs should be of equal length.
- B. Place tubular heat shrink insulation over the foil and drain wire on all cut ends of the shielded lead-in cable pairs to insure drain wire and conductive side of foil are insulated from all other foils and drain wires.
- C. Insert the wires into the appropriate sized end of the Multilink part # ML56-16, or approved equal, splice connector. Crimp and heat the connector in accordance with manufacturer's installation instructions.
- D. Secure cable/conductor bundle with nylon cable ties.
- E. Seal the connection in a clear re-enterable-encapsulating splice kit as shown on the detail. All cable and conductor sheaths shall extend a minimum of one inch (1") into re-enterable encapsulating compound. A half inch (1/2") of free space, measured from the outside dimensions of the splice cables/conductors to the inside dimensions of the splice tube kit, shall be left around the circumference and at the ends of all splice cables/conductors. Free space shall be completely filled with approved re-enterable encapsulating compound so that there is no space for water to sit inside of splice kit when kit is stood up vertically.

The Contractor shall conduct a megohm meter test at five hundred (500) volts DC on all loops. The ends of the loops shall be temporarily spliced together and the resistance to ground measured. The resistance shall not be less than one hundred (100) megohm. If the resistance is less than one hundred (100) megohm, the Contractor shall be responsible for correcting the problem(s), and the test shall be repeated until passed. The test shall be performed at the time of the pre-final inspection or when the signal is put into operation, whichever comes first; however, the Contractor is encouraged to test the loops to his own satisfaction prior to inspection.

The DC resistance between two (2) ends of the same loop wire shall be measured and shall not exceed one and one-half (1.5) ohms per one hundred (100) circuit feet. Where existing lead-in cable is being used, the Contractor shall perform the above tests on the lead-in cable prior to splicing with the loop wires. If the tests on the existing lead-in cable

are not satisfactory, the Engineer may request that it be replaced at an appropriate negotiated price.

All the above tests are to be performed, and the results recorded, by the Contractor in the presence of the Engineer. The Contractor shall supply all the test equipment and deliver signed legible copies of the test reports to the Engineer.

Conduit-encased loop wires shall be No. 14 AWG stranded copper wire with PVC tube (IMSA Spec. 51-5).

Each detector loop shall be connected to its own detector lead-in pair of seven (7) pair #18 shielded conductor cable to be used for detector lead-ins. All parallel and series connections shall be made at the cabinet terminal strip.

The upstream and intermediate loop home runs shall be routed to the nearest junction box along a path perpendicular to the direction of travel. Home runs for adjacent loops less than sixteen feet (16') apart shall be routed to the nearest junction box in the same trench to the extent possible to minimize excavation of the pavement.

The stop bar loop home runs will generally be routed to the same junction box. All the home runs shall be routed parallel and adjacent to each other along a path perpendicular to the direction of travel. A path parallel to the direction of travel may be needed from the individual loop to the common perpendicular routing.

Loop locations may be staggered plus or minus six inches ($\pm 6"$) to accommodate home run placement.

The loop conduit shall be PVC Schedule 80, conforming to ASTM D1785, except that the "X" connection of the loop to the home run shall be a hot dip galvanized steel conduit. The Contractor shall use one inch (1") diameter conduit.

The home run conduit shall be PVC Schedule 80.

For installation of loops in new construction, loops will be placed in compacted leveling course bedding material conforming to Division 20, Section 20.22 – Leveling Course. There shall be a minimum thickness of one inch (1") of leveling course beneath the loop conduit and conduit. A minimum of one inch (1") of compacted leveling course shall be placed on top of the loop conduit and conduit prior to paving.

Sand bedding shall be non-frost-susceptible, consisting of naturally occurring fine mineral aggregates free of clays, silt, or organic matter.

In constructing conduit encased detector loops, the Contractor shall be responsible for devising his own methods of cutting and restoring the existing asphalt concrete pavement, provided that his methods:

- A. Allow for the maintenance of traffic through the construction zone, and;

- B. When installing loop detectors in existing pavement, cut the asphalt with a saw and remove all asphalt within the saw cut, and;
- C. Replace asphalt concrete in two (2) equal lifts, with a minimum thickness of three inches (3") or the existing pavement thickness, whichever is greater, and;
- D. Provide for reconstruction of the base material and asphalt concrete, in accordance with Division 20 - Earthwork and Division 40 - Asphalt Surfacing, and;
- E. Are approved by the Engineer.

Full-lane-width asphalt patching is required. Any remaining section less than twelve feet (12') between loops must be replaced to provide a continuous patch. The Contractor shall adhere to the following guidelines:

- A. Where existing pavement will not be overlaid, enclose all loops that enter a common junction box within a trapezoidal saw-cut.
- B. Cut to within one foot (1') of the lane and edge lines, preserving the pavement markings.
- C. Remove the asphalt to the lip of the gutter when there are no edge lines.
- D. Cut across lane lines when loops in adjacent lanes are side by side.
- E. Cut trenches a minimum of three feet (3') wide installing loop tails across a lane.
- F. Trenches crossing a shoulder only may be a minimum of one foot (1') wide.
- G. Contractor shall saw-cut asphaltic concrete pavement for loops in existing pavement.
- H. All existing pavement between detection loops within twelve feet (12') of another loop shall be saw-cut and removed, then repaved continuously.
- I. All traffic markings removed as a result of loop installation in existing pavement shall be replaced to the original alignment and messages.

After the asphalt concrete pavement has been removed according to the Contractor's approved method, the area where the conduit-encased detector loop is to be placed shall be cleared of all rocks and protrusions which may damage the conduit. Sand bedding or leveling course may be required by the Engineer to attain an adequate surface. The Contractor shall take care that the subgrade is not disturbed. If the subgrade material is disturbed, the Contractor shall compact the surface to the satisfaction of the Engineer.

The conduit-encased detector loop shall then be installed and sand bedding or leveling course shall be placed over the loop to a minimum of one inch (1") compacted depth.

An asphalt tack coat per Division 40, Section 40.04 – Tack Coat, shall be applied to all edges of the existing pavement prior to placing new asphalt. Asphalt concrete pavement shall be placed and compacted in a minimum of two (2) equal lifts per Division 40 – Asphalt Surfacing.

When loops are installed in existing pavement or as new Work, traffic shall not be allowed to drive over the loops until the first layer of asphalt has been placed.

Article 18.2 Optical Detectors - Preemption

Any substitutions of cable, material or equipment in this Article must be submitted to the Municipal Traffic Engineer for testing and approval prior to installation.

Before installing the Optical Detectors, gain approval of their final lateral location on the mast arms from the Municipal Traffic Engineer or assigned designee.

Install the following components of the 3M Company's Opticom Priority Control System in accordance with 3M's written installation instructions at each signalized intersection listed on the Drawings:

- A. Install the quantity of Model 711, 721, or 722 Optical Detectors on the traffic signal pole mast arms as shown on the Drawings. Mounting hardware shall consist of Pelco Products, Inc. "Astro Mini-Brac" Band Mount Clamp Kits, or approved equal, and 3M Company "M575 Confirmation Light Hardware" Installation Kit, or approved equal. See the Drawings for installation details.
- B. Install Model 138 Optical Detector lead-in cable and a three-conductor #14 AWG signal cable between each optical detector and the controller cabinet. Furnish enough slack in these cables to extend two feet (2') beyond the end of each signal mast arm and to leave ten feet (10') of slack in the controller cabinet. Label each cable.
- C. Before attaching the conductors to the optical detector, strip the insulation from the conductors in the Model 138 cable and attach all four (4) conductors to chassis ground in the controller cabinet. Attach the signal cable to the confirmation light. The Traffic Signal Electronics Shop will make final terminations of the conductors in the controller cabinet.
- D. When retrofitting existing controller cabinets, furnish each controller assembly with two (2) Model 754 phase selector, a Model 760 card rack, and an Opticom Panel Assembly, U.S. Traffic Corporation part number 103303. Deliver these parts to the Traffic Signal Electronics Shop Foreman.

New controller cabinets shall include these parts installed by the controller assembly manufacturer per Section 80.17, Article 17.4 - Special Auxiliary Equipment.

Article 18.3 Radar Detectors

Radar detectors may not be used without prior approval of the Traffic Engineer. Any substitutions of cable, material or equipment in this Article must be submitted to the Traffic Engineer for testing and approval prior to installation.

Radar detectors shall be Microwave Sensors Model TC26B sensors that operate in the X-band radar frequency and use microprocessor analyzed Doppler-microwave detection method for detecting vehicles moving toward or away from the unit. They shall be installed in accordance with the manufacturers written installation instructions and the following requirements:

A. Install a sixty-hertz (60 hz) transformer with one hundred twenty (120) volt AC primary and twenty four (24) volt AC secondary in the controller cabinet. Follow the manufacturer's requirements for current output per detector. Furnish a UL-listed, Class 2 rated transformer with built-in overload and short circuit protection.

B. A fuse block shall be provided with four (4) fuses to protect the twenty-four (24) volt AC transformer secondary and isolation relay from damage due to faults outside of the controller cabinet assembly.

C. Home-Run Cable

Wire each sensor using a color-coded three (3) pair cable such as Alpha Wire Company cable part # 6314 or Beldon part # 9883, or approved equal.

Pair 1 shall be black paired with red and shall be used to supply power to the unit.

Pair 2 shall be black paired with white and shall be tied back at both ends.

Pair 3 shall be black paired with green and shall connect to the relay contacts in the unit. In the cabinet, this pair shall be connected to the twenty-four (24) volt AC transformer secondary and the isolation relay.

D. Isolation Relay

For each detector, a socket-mounted isolation relay shall be provided for the controller cabinet assembly. The relay shall be an RH1B-UAC24V with snap mount socket and aluminum din rail. One leg of the relay coil shall connect to the twenty-four (24) volt AC transformer secondary while the other leg shall be fused and connect to the detector unit relay.

Article 18.4 Ultrasonic Detectors - Ultrasonic Presence Sensors

Ultrasonic detectors may not be used without prior approval of the Traffic Engineer. Any substitutions of cable, material or equipment in this Article must be submitted to the Traffic Engineer for testing and approval prior to installation.

Ultrasonic detectors shall be Microwave Sensors Model TC30C. They shall be installed in accordance with the manufacturer's written installation instructions.

At the locations shown on the Drawings, install sensors that operate at an ultrasonic frequency and sample for the presence of stationary and moving vehicles at a rate of ten (10) times per second. Furnish sensor units that:

- A. Feature solid-state circuitry and a high-speed transducer with the sensitivity to detect a motorcycle. The cone of coverage produced by the transducer should measure at least four feet (4') in diameter at twenty one feet (21') from the transducer. The unit shall provide a continuous call to the controller unit with the presence of a vehicle in its cone of coverage or whenever the unit loses power.
- B. Include an external control to adjust the length of the cone of coverage, an external detection light emitting diode, and mounting brackets suitable to install the units on traffic signal pole mast arms.
- C. Require no external amplifiers, seasonal tuning, or special cabling, and which operate at all temperatures from -31°F to 167°F (-35°C to 75°C).
- D. Operate on a voltage of twelve (12) to twenty-four (24) volts AC.
- E. Install a sixty-hertz (60 hz) transformer with one hundred twenty (120) volt AC primary and twenty-four (24) volt AC secondary in the controller cabinet. Follow the manufacturer requirements for current output per detector. Furnish a UL-listed, Class 2 rated, transformer with built in overload and short circuit protection.
- F. A fuse block shall be provided with four (4) fuses to protect the twenty-four (24) volt AC transformer secondary and isolation relay from damage due to faults outside of the controller cabinet assembly.
- G. Home-Run Cable

Wire each sensor using a color coded three (3) pair cable such as Alpha Wire Company cable part # 6314 or Beldon part # 9883, or approved equal.

Pair 1 shall be black paired with red and shall be used to supply power to the unit.

Pair 2 shall be black paired with white and shall be tied back at both ends.

Pair 3 shall be black paired with green and shall connect to the relay contacts in the unit. In the cabinet, this pair shall be connected to the twenty-four (24) volt AC transformer secondary and the isolation relay.

H. Isolation Relay

For each detector, a socket-mounted isolation relay shall be provided for the controller cabinet assembly. The relay shall be an RH1B-UAC24V with snap mount socket and aluminum din rail. One leg of the relay coil shall connect to the twenty-four (24) volt AC transformer secondary while the other leg shall be fused and connect to the detector unit relay.

Article 18.5 Video Detectors

Video Detectors shall not be used without prior approval of the Traffic Engineer.

Article 18.6 Measurement

Loop detectors will be measured as units, complete and in place, including all labor, equipment, specified materials and miscellaneous materials to provide a complete and functioning unit, including the home run to the nearest junction box. Bid item "Install Loop Detectors in Existing Pavement" will include all costs of cutting and restoring existing pavement.

Optical preemption detectors, radar detectors and ultrasonic detectors shall be measured as units, complete and in place, including all labor, equipment, specified materials and miscellaneous materials to provide a complete and functioning unit, including all wiring to the controller cabinet assembly and all hardware installed in the cabinet.

Article 18.7 Basis of Payment

Payment for this Work shall be in accordance with Division 10, Section 10.07, Measurement and Payment, and shall include full payment for all Work described in this Section.

Payment will be made under the following units:

ITEM	UNIT
Install Loop Detector - New Work	Each
Install Loop Detector - Existing Pavement	Each
Install Optical Preemption Detector (Type)	Each
Install Radar Detector	Each
Install Ultrasonic Detector	Each

SECTION 80.19 VEHICLE SIGNAL HEADS

Article 19.1 General

All signal heads shall conform to the ITE Specification "Adjustable Face Vehicular Traffic Control Signal Heads." Each signal head shall be adjustable, vertical type with the number and type of sections as specified herein and shown on the Drawings; shall provide an indication in one direction only; shall be adjustable through 360 degrees about a vertical axis; and shall be mounted at the location and in the manner shown on the plans.

Vehicle Signal Heads shall have Light Emitting Diode (LED) lamps for all red, green and yellow indications. Red, green and yellow lamps shall conform to Article 19.4 – Light Emitting Diode (LED) Optical Units.

Each lens shall be provided with a removable tunnel visor, with an open slot at the bottom. The visor shall be constructed of aluminum. The color shall be Econolite green and black.

Vehicle signal housings shall conform to the following:

1. All parts of the housing, including the doors and end plates, shall be of die cast aluminum conforming to the specifications of ASTM B85, and all parts shall be clean, smooth, and free from flaws, cracks, blow holes, or other imperfections, unless otherwise called for on the plans.
2. The housing of each signal section shall be one piece with integral top, bottom, and sides, with square doors.
3. All exposed bolts, screws, hinges pins, and door locking devices shall be stainless steel. All interior screws and fittings shall be stainless steel or approved non-ferrous, corrosion-resistant material.
4. The top and bottom of each housing shall have an opening to accommodate standard one and one-half inch (1-1/2") pipe fittings and brackets.
5. The top and bottom opening of the housing shall have an integral serrated boss that will provide positive positioning of the signal head in five (5) degree increments to eliminate undesirable rotation or misalignment of the signal head as well as between sections. A total of seventy-two (72) teeth shall be provided in the serrated boss. The teeth shall be clean and sharp to provide positive positioning with the grooves of the mating section or framework.
6. Individual signal sections shall be fastened together with a cadmium-plated tri-stud connector, lock washers, and nuts with access holes for the passage of electrical conductors from one section to another.
7. Each signal housing shall have two (2) integral hinge lugs located on the left side for mounting the door.

8. One (1) or two (2) latches shall be provided on the right side of each signal housing with stainless steel wing nut assemblies for the purpose of engaging the door latches.
9. Each signal housing shall have a door opening for the periphery which shall have a soft, closed-cell neoprene gasket to provide a weather-tight seal with the mating door.
10. The door of each signal housing shall be provided with a round opening designed to accommodate any standard traffic signal lens.

Article 19.2 Installation

- A. Vehicle signal heads shall not be installed at any intersection until all other signal equipment, including the controller, is in place and ready for operation at that intersection, unless the faces are not directed toward traffic or unless the faces are adequately covered. Contractor shall cover heads with beige colored canvas shirts sized to fit the signal faces shown in the Drawings. Each shirt shall feature elasticized openings that fit over the visors and at least two straps to secure it to the signal. Provide shirts with a legend that reads "out of service" and a center section that allows an operator to see the indications during system tests.
- B. Signal heads, backplates, visors, mounting brackets and fittings shall be painted as specified in Section 80.16, Article 16.4 - Painting for Steel Structures.
- C. Vehicle signal head mounting hardware shall be attached to the side of pole that faces away from traffic unless otherwise approved by the Engineer.
- D. All conductor access holes drilled for side mounted vehicular signal heads shall be deburred inside and out to prevent scraping of the conductors. The holes shall be cleaned and painted with two (2) coats of zinc chromate primer for metal.
- E. Through phase vehicle signal faces shall be aimed at a point located a distance from the face as shown in the following table. If two (2) through signal faces are not visible from this point at an eye height of three and one-half feet (3.5') above finished grade, then the Traffic Engineer shall be consulted for corrective measures.

Signal Head Visibility Distances

<u>Posted Speed Limit (mph)</u>	<u>Minimum Visibility Distance (ft.)</u>
20	328
25	394
30	460
35	540
40	390
45	624
50	722
55	820
60	902

- F. Backplates shall be attached to the signal head using plated steel rivets with large flange button heads. The rivet shall be two-tenths inches (0.2”) in diameter and 0.575 inches long and at least 2380 N and 3000 N shear and tensile strength, respectively. Bore out the mounting holes in the backplates and signal heads to the diameter recommended by the rivet manufacturer.
- G. Each lens shall be provided with a removable tunnel visor, with an open slot at the bottom, constructed of aluminum and securely installed using machine screws. The threads of the machine screws shall be coated with an antiseizing compound before installation.
- H. Removal and relocation of existing signal heads, as shown on the Drawings, shall utilize new mounting hardware.
- I. When installing LED signal heads, the Contractor shall clearly and permanently mark the date installed on the back of each unit.

Article 19.3 Signal Head Mounting

Mast arm mounted signal head locations shown on the Drawings are approximate. Signal heads shall be installed over lane lines or over the center of lanes, as shown on the Drawings. Mounting locations shall be verified using the as-built lane markings and signal pole foundation location. Obtain the approval of the Engineer before wire access holes are drilled in mast arms.

A. Mast Arm Signals

Signal head assembly for suspension from mast arm shall be equipped with a bronze plumbizer.

All holes in mast arms shall be field drilled to ensure proper location of signal heads with respect to traffic lanes. Arms shall be drilled for wire accesses after installation on the base of the pole. The wire hole locations shall be directly centered on the mounting bracket on the signal head side of the mast arm.

All mast arm mounted signal heads shall be mounted using "Astro-Brac" band mount clamp kits part number AB-3007-L (**with stainless upgrade option**), brackets manufactured by Pelco Products Inc., or an approved substitute. The mounting nipple shall be a two inch (2") rigid metal conduit, cut to a length of six inches (6"). The mounting nipple shall have one inch (1") of tapered thread on one end, be drilled to accept the plumbizer through bolt and all openings shall be deburred.

B. Pole and Post Mounted Signals

Bracket mounted signal heads, as shown on the Drawings, shall be supported by mounting brackets consisting of watertight assemblies of one and one-half inch (1 1/2") standard steel pipe and malleable iron or brass pipe fittings. All members shall be either plumb or level, symmetrically arranged, and securely assembled. Construction shall be such that all conductors are concealed within the assembly.

The horizontal nipples shall be of adequate length to achieve the required offsets indicated on Standard Details 80-27 and 80-29. Offsets are calculated from center of signal head mounting opening to center of vertical riser on terminal compartments. Side mounted frames twenty-two inches (22"), double head post top mount eleven inches (11"), and single head post top mount six inches (6").

Where four- (4-) or five- (5-) section vertical signal heads are side mounted on poles, a steel conduit hanger shall be installed on the vertical framework pipe, six inches (6") down from the upper horizontal framework pipe. A conduit hanger shall be mounted to the pole with a five-sixteenth inch (5/16") bolt and lock washer.

Pole side mounted traffic signal heads shall be mounted on the back side of pole unless noted or detailed otherwise on the Drawings. The pole/post-mounted traffic signal heads shall be mounted so that no portion of the backplates are hidden by the pole/post.

At each signal location, unless otherwise shown on the Drawings, a terminal compartment shall be constructed into the mounting brackets.

For post-top mounting of bracket mounted signals, the terminal compartment shall be cast with an integral slip-fitter.

For post-top mounting of a one-way signal head, a slip-fitter without a terminal compartment may be used.

Post-top signal heads with backplates shall be mounted with an offset slip-fitter to allow the signal head backplate to clear the signal pole.

Attach each side mounted terminal compartment with two one-half by thirteen inch (1/2" x 13") bolts with washers, threaded into holes tapped into the side of the pole.

C. Programmed Visibility Traffic Signal Heads

The Contractor shall program the head as recommended by the manufacturer and as directed.

When programmed, each signal face's indication shall be visible only in those areas or lanes to be controlled, except that during dusk and darkness a faint glow to each side will be permissible.

Article 19.4 Light Emitting Diode (LED) Optical Units

All LED vehicle lamps shall be GELcore, Dialight or an approved equal. Any substitutions must be submitted to the Traffic Engineer for testing and approval prior to bid award. LED vehicle lamps shall meet the following specifications:

A. Definition

1. Eight inch (8") and twelve inch (12") indications for all vehicle traffic signals faces shall utilize light emitting diode signal modules.
2. Light emitting diode (LED) signal modules shall consist of an assembly that utilizes light emitting diodes as the light source in lieu of an incandescent lamp for use in traffic signal sections.

B. General

1. LED signal modules shall be designed to be installed in the doorframe of a standard traffic signal housing. The lamp socket, reflector, reflector holder and lens used with an incandescent lamp shall not be used in a signal section in which an LED signal module is installed.
2. LED signal modules shall be a sealed unit with two (2) conductors for connecting to power, a printed circuit board, power supply, a lens and gasket, and shall be weather proof after installation and connection. The circuit board and power supply shall be contained inside the module.
3. Conductors for modules shall be forty inches (40") in length, with insulated quick disconnect terminals.
4. The lens of the module shall be integral to the unit, shall be convex with a smooth outer surface and made of ultraviolet stabilized plastic or of glass. The lens shall be capable of withstanding ultraviolet (direct sunlight) exposure for a minimum period of five (5) years without exhibiting evidence of deterioration.
5. The module shall be sealed in the door frame with a one-piece EPDM (ethylene propylene rubber) gasket.
6. The LEDs shall utilize AlInGaP technology and shall be the ultra bright type rated for 100,000 hours of continuous operation from -40°F to 165°F (-40°C to 74°C). AlGaS LEDs will not be allowed.

7. The failure of an individual LED in a string shall only result in the loss of that LED, not the entire string or indication.
8. Furnish LED signal modules rated for a minimum useful life of sixty (60) months and that meet current ITE Standards for LED signal modules.

C. Physical and Mechanical Requirements

1. LED traffic signal modules shall be designed as retrofit replacements for existing optical units of signal lamps and shall not require special tools for installation. LED signal modules shall fit into existing traffic signal section housings built to the VTCSH standard without modification to the housing.
2. Installation of an LED signal module shall only require the removal of the optical unit components, i.e., lens, lamp module, gaskets, and reflector; shall be weather tight and fit securely in the housing; and shall connect directly to electrical wiring.

LED Signal Module Lens. The LED signal module shall be capable of replacing the optical unit. The lens may be tinted or may use transparent film or materials with similar characteristics to enhance ON/OFF contrasts. The use of tinting or other materials to enhance ON/OFF contrasts shall not affect chromaticity and shall be uniform across the face of the lens.

If a polymeric lens is used, a surface coating or chemical surface treatment shall be used to provide front surface abrasion resistance.

Environmental Requirements. The LED signal module shall be rated for use in the operating temperature range of -40°F to 165°F (-40°C to 74°C).

The LED signal module shall be protected against dust and moisture intrusion per the requirements of NEMA Standard 250-1991 for Type 4 enclosures to protect all internal components.

The LED signal module lens shall be UV stabilized.

Construction. The LED signal module shall be a single, self-contained device, not requiring on-site assembly for installation into an existing traffic signal housing. The power supply for the LED signal module shall be integral to the unit.

Module Identification. Each LED signal module shall have the manufacturer's name, trademark, and other necessary identification permanently marked on the back of the module. Each individual LED signal module shall be identified for warranty purposes.

The following operating characteristics shall be identified: rated voltage, power consumption, and volt-ampere.

Each LED signal module shall have prominent and permanent vertical marking(s) for correct indexing and orientation within signal housing. The markings shall consist of an up arrow, or the word "UP" or "TOP."

D. Photometric Requirements

1. LED traffic signal modules shall meet at least eighty-five percent (85%) of the minimum VTCSH intensity requirements while operating throughout the operating temperature range of -40°F to 165°F (-40°C to 74°C).
2. The minimum initial luminous intensity values for LED traffic signal modules shall be as defined in Section 11.04 of the VTCSH standard at 77°F (25°C).
3. The measured chromaticity coordinates of LED signal modules shall conform to the chromaticity requirements of Section 8.04 and Figure 1 of the VTCSH standard.

E. Electrical

1. LED signal modules shall operate from a sixty-hertz (60 Hz) ± 3 Hz AC line over a voltage ranging from eighty (80) volts to one hundred thirty-five (135) volts. The LED circuitry shall prevent perceptible flicker over the voltage range specified above. The fluctuations of line voltage shall have no visible effect on the luminous intensity of the indications. Rated voltage for all measurements shall be one hundred twenty (120) volts. The LED traffic signal lamp unit shall not be capable of functioning at less than forty-five (45) volts.
2. All wiring and terminal blocks shall meet the requirements of Section 13.02 of the VTCSH standard. Two (2) secured, color-coded, 1 m long 600 V, 20 AWG minimum, jacketed wires, conforming to the National Electric Code, rated for service at 221°F (+105°C), are to be provided for electrical connection for each LED signal module.
3. The signal module on-board circuitry shall include voltage surge protection to withstand high-repetition noise transients as stated in Section 2.1.6 of NEMA Standard TS-2, 1992.
4. LED signal modules shall be operationally compatible with currently used controller assemblies (solid state load switches, flashers, and conflict monitors).
5. LED signal modules and associated on-board circuitry must meet Federal Communications Commission (FCC) Title 47, Subpart B, Section 15 regulations concerning the emission of electronic noise.

6. The LED signal module shall provide a power factor of nine-tenths (0.90) or greater.
7. Total harmonic distortion (current and voltage) induced into an AC power line by a LED signal module shall not exceed twenty percent (20%).

F. Production Testing Requirements

1. Each new LED traffic signal lamp unit shall be energized for a minimum of twenty-four (24) hours at operating voltage and at a temperature of 140°F (60°C) in order to cause any electronic infant mortality to occur, and to ensure electronic component reliability prior to shipment.
2. After the burn-in procedure is completed, each LED traffic signal lamp unit shall be tested by the manufacturer for rated initial intensity at rated operating voltage.

G. Warranty

The manufacturer shall provide a written warranty against defects in materials and workmanship for the LED signal modules for a period of sixty (60) months after installation of the modules. Replacement modules shall be provided promptly after receipt of modules that have failed at no cost to the Owner except cost of shipping of the failed modules. Provide the Engineer with all warranty documentation prior to installation. Deliver the replacement modules to Traffic Signal Electronics Shop within five (5) working days of notification. The warranty does not include the costs associated with removing and reinstalling units that are replaced or repaired.

Article 19.5 Incandescent Optical Units

- A. Each optical unit shall consist of a lens, a reflector, a lamp holder, and a clear incandescent traffic signal lamp.
- B. Lenses shall be circular in shape and glass construction.
- C. The lamp holder shall be secured to the reflector to provide a dust and moisture proof seal.
- D. The reflector and lamp holder shall be held securely in place with the outer edge of the reflector engaging the lens gasket to provide a light and moisture seal for the entire optical assembly.
- E. All lamp holders shall be so wired that a white wire will be connected to the shell of the lamp holder and a black or colored wire to the bottom or end terminal of the lamp holder. These wires shall, in turn, be connected to the terminal block mounted inside at the back of the housing. The terminal block shall have sufficient screw type terminals to terminate all field wires and lamp wires independently, with separate screws. The terminals to which field wires are attached shall be

permanently identified or wiring shall be color-coded to facilitate fieldwork. The terminal block shall be located in the center section of the head.

- F. Lamps for the twelve inch (12") units shall be 1,950 lumen minimum initial output, 120 volt, 6,000 hour rated life, clear, traffic signal lamps, unless specified otherwise in the Drawings.
- G. Lamps for the eight inch (8") units shall be 665 lumen minimum initial output, 120 volt, 6,000 hour rated life, clear, traffic signal lamps.
- H. Reflectors shall be made of Alzak finished aluminum, the thickness of the anodic coating to be a minimum of 0.0001 inches, or its equivalent, spun or drawn from metal not less than 0.025 inches thick equipped with a bead or flange on the outer edge to stiffen the reflector and insure its being held true to shape. The reflecting surface shall be totally free of flaws, scratches, defacements or mechanical distortion.

Article 19.6 Backplates

Backplates shall be furnished and attached to all vehicle signal heads, including programmed-visibility signal heads, except for post-mounted flashers which will be installed without backplates.

Backplates shall be aluminum and the color shall be Econolite green and black. Backplate extensions (borders) shall be five inches (5") wide. Where a backplate consists of two (2) or more sections, they shall be fastened together with aluminum rivets or bolts and peened after assembly to prevent loosening.

Construct backplates of 0.063-inch minimum thickness aluminum alloy sheet meeting ASTM B 209, alloy 3003-H14.

Backplates shall be painted as specified in Section 80.16, Article 16.4 – Painting for Steel Structures.

Article 19.7 Signal Head Mounting Hardware

A signal head assembly for suspension from mast arm shall be equipped with a bronze plumbizer.

All mast arm mounted signal heads shall be mounted using "Astro-Brac" band mount clamp kits part number AB-3007-L **(with stainless upgrade option)** brackets manufactured by Pelco Products, Inc., or an approved substitute. The mounting nipple shall be a two inch (2") rigid metal conduit, cut to a length of six inches (6"). The mounting nipple shall have one inch (1") of tapered thread on one end, be drilled to accept the plumizer through bolt, and all openings shall be deburred.

A. Pipe and Fittings

Bracket mounting hardware shall be one and one-half inch (1 1/2") standard steel pipe and malleable iron or brass pipefittings. Construction shall be such that all conductors are concealed within a watertight assembly.

Signal heads shall be equipped with positive brass lock rings and fittings designed to prevent heads from turning due to external forces. Lock ring and connecting fittings shall have serrated contacts.

B. Terminal Compartment

Terminal compartments shall be bronze of sufficient strength to remain intact in event the pole is knocked down.

For post-top mounting of bracket mounted signals, the terminal compartment shall be cast with an integral slip-fitter. Each terminal compartment shall be fitted with a terminal block containing twelve (12) poles, each with two (2) screw type terminals. Each terminal shall accommodate at least three (3) No. 14 AWG conductors. A raintight cover shall be provided, giving ready access to the terminal block.

C. Slip-fitters

Slip-fitter shall fit over a four inch (4") standard pipe or four and one-half inch (4 1/2") outside diameter end of tapered standard. Each slip-fitter shall be provided with two (2) rows of steel set screws, with three (3) screws in each row to secure the assembly in plumb position. Set screws shall be cadmium plated.

Slip-fitters, where used without integral terminal compartment, shall be of cast-iron.

Post-top signal heads with backplates shall be mounted with an offset slipfitter to allow the signal head backplate to clear the signal pole.

D. Painting

Mounting brackets and fittings shall be painted as specified in Section 80.16, Article 16.4 – Painting for Steel Structures.

Article 19.8 Programmed Visibility Traffic Signal Heads

Each programmed visibility signal face and the installation thereof shall conform to the provisions of Article 19.1 - General; Article 19.2 - Installation; Article 19.3 - Signal Head Mounting; and Article 19.7 - Signal Head Mounting Hardware, except as modified in this subsection.

Each programmed visibility signal section shall provide a nominal twelve inch (12") diameter circular or arrow indication. Color and arrow configuration shall conform to the latest I.T.E. Specification.

Each section shall be provided with a sun visor.

Each signal section shall be provided with an adjustable connection that permits incremental tilting from zero (0) to ten (10) degrees above or below the horizontal while maintaining a common vertical axis through couplers and mounting axis in five (5) degree increments.

The signal shall be mountable with ordinary tools and capable of being serviced without tools. Adjustment shall be preset at four (4) degrees below the horizontal, unless otherwise specified.

The visibility of each programmed visibility signal face shall be capable of adjustment or programming within the face. When programmed, each signal face's indication shall be visible only in those areas or lanes to be controlled, except that during dusk and darkness a faint glow to each side will be permissible.

Prior to programming, each signal section with a yellow indication shall provide a minimum luminous intensity of three thousand (3,000) candela on the optical axis, and a maximum intensity of thirty (30) candela at fifteen (15) degrees horizontal from the axis. Each such signal section shall be capable of having its visibility programmed to achieve the following luminous intensities: a minimum of 3,000 candela on the optical axis, a maximum of one hundred (100) candela at from one-half (1/2) to two (2) degrees horizontal from the axis and a maximum of ten (10) candela at from two (2) to fifteen (15) degrees horizontal from the axis. Under the same conditions, the intensities of the red indication and the green indication shall be at least nineteen percent (19%) and thirty-eight percent (38%) respectively of the yellow indication.

Each signal face or each signal section shall include integral means for regulating its luminous intensity between limits in proportion to the individual background luminance. Lamp intensity shall not be less than ninety-seven percent (97%) of uncontrolled intensity at 1000 foot-candles, and shall reduce to 15±two percent of maximum intensity at less than one foot-candle. The dimming device shall operate over an applied voltage range of ninety-five (95) to one hundred thirty (130) volts, sixty hertz (60 Hz) and a temperature range of -40°C to 74°C.

The Contractor shall supply the material required for programming of the head. The programming of the head shall be accomplished by the Traffic Signal Electronics Shop.

Article 19.9 Measurement

New and relocated signal heads will be measured as units, complete and in place, including all labor, mounting hardware, equipment and materials to provide a complete and functioning unit. Measurement shall be for the actual number of existing signal heads removed and relocated, and the actual number of new signal heads having the specified number of indicators of the specified size. Left arrow, right arrow, and round ball faces of the same size will be considered identical pay items.

Article 19.10 Basis of Payment

Payment for this work shall be in accordance with Division 10, Section 10.07 - Measurement and Payment, and shall be full payment for all Work described in this Section.

Payment will be made under the following units:

ITEM	UNIT
(8 or 12) inch (3, 4, 5) Face Signal Head	Each
Remove and Relocate Existing Signal Head	Each

SECTION 80.20 PEDESTRIAN SIGNALS

Article 20.1 General

Pedestrian signals shall be the Light Emitting Diode (LED) Type.

Pedestrian signals shall show the following:

1. Steady "WALKING PERSON" during the pedestrian interval.
2. Flashing "HAND" and countdown time "XX" in seconds during the pedestrian clearance interval.
3. Steady "HAND" after the pedestrian clearance and during the associated phases yellow and all red vehicle clearance intervals.
4. Dark during intersection flash.

Pedestrian signal mounts shall be two-piece hinge connected type (clamshell) unless otherwise shown on the Drawings.

Conductors shall be #14 AWG or larger conforming to IMSA Specification 20-1.

Article 20.2 Installation

Pedestrian signal heads shall be directed at the center of the crosswalk on the opposite side of the street.

Pedestrian signal heads shall not be installed at any intersection until all other signal equipment, including the controller, is in place and ready for operation at that intersection, unless the faces are not directed toward traffic or unless the faces are adequately covered. Contractor shall cover heads with beige colored canvas shirts sized to fit the signal faces shown in the Drawings. Each shirt shall feature elasticized openings that fit over the visors and at least two straps to secure it to the signal. Provide shirts with a legend that reads "out of service" and a center section that allows an operator to see the indications during system tests.

Pedestrian signal head mounting hardware shall be attached to the side of pole that faces away from traffic unless otherwise approved by the Traffic Engineer.

All conductor access holes drilled for side mounted pedestrian heads shall be deburred inside and out to prevent scraping of the conductors. The holes shall be cleaned and painted with two (2) coats of zinc chromate primer for metal.

Removal and relocation of existing signal heads, as shown on the Drawings, shall utilize new mounting hardware.

When installing LED signal heads, the Contractor shall clearly and permanently mark the date installed on the back of each unit.

Article 20.3 Mounting

Side mounted pedestrian signal hardware shall consist of a two-piece, hinge connected, cast aluminum bracket that mounts directly between the pole and the side of the signal head housing. Clearance between the head and pole shall not exceed three inches (3"). The bracket shall properly fit any round pole four inches (4") or greater in diameter and be capable of being rotated a minimum of thirty (30) degrees when mounted on a four inch (4") pole. A raintight, three (3) position terminal block shall be contained within the mounting bracket.

Bracket mounted signal heads, as shown on the Drawings, shall be supported by mounting brackets consisting of watertight assemblies of one and one-half inch (1 1/2") standard steel pipe and malleable iron or brass pipefittings. All members shall be either plumb or level, symmetrically arranged, and securely assembled. Construction shall be such that all conductors are concealed within the assembly. A terminal compartment shall be constructed into the mounting bracket.

At each signal location, unless otherwise shown on the Drawings, a terminal compartment shall be constructed into the mounting brackets.

Terminal compartments shall be bronze of sufficient strength to remain intact if the pole is knocked down.

Mounting brackets and fittings shall be painted as specified in Section 80.16, Article 16.4 – Painting for Steel Structures.

Attach each clamshell bracket with two one-half by thirteen inch (1/2" x 13") bolts threaded into holes tapped into the side of the pole. Install a spacer, furnished by the bracket manufacturer, on each bolt.

Article 20.4 Housing

- A. The case shall be a one-piece, corrosion-resistant, aluminum-alloy die-casting complete with integrally cast top, bottom, sides and back. Four (4) integrally cast hinge lug pairs, two (2) at the top and two (2) at the bottom of each case, shall be provided for operation of a swing-down door.
- B. The case for pedestrian signals shall be dustproof, weatherproof, corrosion resistant, and shall provide for easy access to, and replacement of, all components.
- C. Three (3) versions of the case shall be available. The first version shall be supplied with clamshell mounting hardware installed (ordered concurrently) for installation of "pole left of message." The second version shall be the "pole right of message." The third version shall contain upper and lower openings as described below suitable for either post top or bracket mounting. The first and second versions need not include upper and lower openings, but when provided shall be plugged to be weathertight.

- D. The third version shall accommodate standard one and one-half inch (1 1/2") pipe brackets, top and bottom. The bottom opening of the signal case shall have a shurlock boss integrally cast into the case. The dimensions of the shurlock boss shall be as follows:

Outside Diameter	2.625 inches
Inside Diameter	1.969 inches
Number of Radial Teeth	72
Depth of Teeth	5/64 inch

The teeth shall be clean and sharp and provide full engagement to eliminate rotation or misalignment of the signal.

- E. The door frame shall be a one-piece, corrosion-resistant, aluminum-alloy die-casting, complete with two (2) hinge lugs cast at the bottom and two (2) latch lugs cast at the top of each door. The door shall be attached to the case by means of two (2) Type 304 stainless steel spring pins. Two (2) stainless steel hinged bolts with captive stainless steel wingnuts and washers shall be attached to the case with the use of stainless steel spring pins. Hence, latching or unlatching of the door shall require no tools.
- F. "Z-crate" or "Egg-crate" type filters shall not be used.
- G. All machine screws, studs and washers shall be stainless steel.
- H. Gaskets shall conform to the provisions in ASTM D-1056, Grade RE 42.
- I. The outside of the housing shall be painted in accordance with the provisions of Section 80.16, Article 16.4 – Painting for Steel Structures.
- J. The housings shall accept a sixteen inch by eighteen inch (16" x 18") pedestrian module.

Article 20.5 Light Emitting Diode (LED) Pedestrian Signal Modules

A. General

LED traffic signal modules shall meet the current ITE standards.

B. Installation

1. LED pedestrian signal modules shall be designed as retrofit replacements for the existing pedestrian signals (ICC 4090 and/or 4094).
2. LED pedestrian signal modules shall not require special tools for installation.

3. LED pedestrian signal modules shall fit into the existing traffic housings built to the PTCSI standard without any modification to the housing.
4. LED pedestrian signal modules shall be weathertight, fit securely in the housing and shall connect directly to existing electrical wiring.
5. Installation of a replacement LED module into the existing pedestrian housing shall only require removal of the existing optical unit components, i.e., lens, lamp, gaskets, and reflector.
6. Each retrofit shall include all necessary components to complete conversion, including a one-piece gasket.
7. Each pedestrian module shall have a sticker attached stating compliance to the ITE standard for color.

C. LED Signal Lens

1. The lens of the LED pedestrian signal modules shall be field replaceable.
2. The lens of the LED pedestrian signal modules shall be polycarbonate UV stabilized and a minimum of six millimeters (6 mm) thick.
3. The exterior of the lens of the LED pedestrian signal module shall be smooth and frosted to prevent sun phantom.

D. LED Pedestrian Signal Module Construction

1. The LED pedestrian signal module shall be a single, self-contained device, not requiring on-site assembly for installation in the existing traffic signal housing.
2. All Portland Orange LEDs shall be “AllnGaP” technology or equal, and rated for 100,000 hours or more at +165°F (+25°C) and twenty milliamps (20 mA). “AllnGaS” technology is not acceptable.
3. Each individual LED traffic module shall be identified for warranty purposes with the manufacturer’s trade name, serial number and operating characteristics, i.e., rated voltage, power consumption, and volt-ampere.

E. Environmental Requirements

1. The LED pedestrian signal modules shall be rated for use in the ambient operating temperature range of -40°F to +140°F (-40°C to +60°C).
2. The LED pedestrian signal modules, when properly installed with gasket, shall be protected against dust and moisture intrusion per requirements of

NEMA Standard 250-1991, Sections 4.7.2.1 and 4.7.3.2, for Type 4 enclosures to protect all internal LED, electronic, and electrical components.

F. Luminous Intensity

1. Pedestrian LED signal modules shall be designed so, that when operated over the specified ambient temperature and voltage range, the signal shall attract the attention of, and be readable to, a viewer (both day and night) at all distances from ten feet (10') to the full width of the area to be crossed.
2. The luminous intensity of the LED pedestrian signal module shall not vary more than $\pm 10\%$ for voltage range of 80 VAC to 135 VAC.

G. Chromacity

The measured chromaticity coordinates of the LED signal modules shall conform to the chromaticity requirements of Section 5.3 and Figure C of PTCSI standard.

H. Electrical

1. The secured, color-coded, one meter (1 m) long, 600V, 20 AWG minimum, jacketed wires, conforming to the National Electrical Code, rated for service at $+221^{\circ}\text{F}$ ($+105^{\circ}\text{C}$), twelve millimeter (12 mm) stripped and tinned are to be provided for electrical connection.
2. The LED pedestrian signal module shall operate from a $60 \pm 3\text{Hz}$ AC line over a voltage range of 80 VAC to 135 VAC. Rated voltage for all measurements shall be 120 ± 3 volts rms.
3. The LED circuitry shall prevent perceptible flicker over the voltage range specified above.
4. The LED pedestrian signal module circuitry shall include voltage surge protection against high-repetition noise transients as stated in Section 2.1.6, NEMA Standard TS-2, 1992.
5. Catastrophic failure of one LED light source shall not result in the loss of more than the light from that one LED.
6. The LED pedestrian module shall be operationally compatible with the currently used controller assemblies. The LED pedestrian module shall be operationally compatible with conflict monitors.
7. The LED pedestrian module including its circuitry must meet Federal Communications Commission (FCC) Title 47, Subpart B, Section 15 regulations concerning the emission of noise.

8. The LED pedestrian module shall provide a power factor of 0.90 or greater over the operating voltage range and temperature range specified above for modules with six (6) watts or more.
9. Total harmonic distortion (current and voltage) induced into an AC power line by an LED pedestrian module shall not exceed twenty percent (20%) over the operating voltage range and temperature range specified above.

I. Production Testing Requirements

1. Each new LED traffic signal lamp unit shall be energized for a minimum of twenty-four (24) hours at operating voltage and at a temperature of 60°C in order to cause any electronic infant mortality to occur, and to ensure electronic component reliability prior to shipment.
2. After the burn-in procedure is completed, each LED traffic signal lamp unit shall be tested by the manufacturer for rated initial intensity at rated operating voltage.

J. Warranty

The manufacturer shall provide a written warranty against defects in materials and workmanship for the LED signal modules for a period of sixty (60) months after installation of the modules. Replacement modules shall be provided promptly after receipt of modules that have failed, at no cost to the Owner except cost of shipping the failed modules. All warranty documentation shall be given to the Engineer prior to installation. The replacement modules shall be delivered to the Traffic Signal Electronics Shop, within five (5) working days after notification. The warranty does not include the costs associated with removing and reinstalling units that are replaced or repaired.

Article 20.6 Measurement

New and relocated pedestrian signal heads will be measured as units, complete and in place, including all labor, mounting hardware, equipment, and materials to provide a complete and functioning unit. Measurement shall be for the actual number of existing pedestrian signal heads removed and relocated, and the actual number of new signal heads installed.

Article 20.7 Basis of Payment

Payment for this Work shall be in accordance with Division 10, Section 10.07 - Measurement and Payment, and shall include full payment for all Work described in this Section.

Payment will be made under the following units:

ITEM	UNIT
Pedestrian Signal Head	Each
Remove and Relocate Pedestrian Signal Head	Each

SECTION 80.21 PEDESTRIAN PUSHBUTTONS

Article 21.1 General

Where shown on the Drawings, pedestrian push buttons of substantial tamper-proof construction shall be furnished and installed. Pedestrian pushbuttons shall be ADA-compliant and either DCC-4EVR 120 (rectangle), or Bulldog RBDLM2-B-4H. Substitutions must be approved by the Traffic Engineer or designated representative.

The assembly shall be weatherproof and so constructed that it will be impossible to receive an electrical shock under any weather conditions.

Where a pedestrian pushbutton is attached to a pole, the housing shall be shaped to fit the curvature of the pole and secured to provide a rigid installation. Saddles shall be provided to make a neat fit when required.

Pushbutton and sign shall be positioned on the sidewalk or pathway side of the pole. Arrows on signs shall point in the same direction as the corresponding crosswalk. Pushbutton and sign shall not contain indicator lights unless specified on the Drawings.

Pedestrian pushbutton signs shall be as detailed in the Manual on Uniform Traffic Control Devices (MUTCD) and the Alaska Sign Design Specifications (ASDS). The R10-3E (9"X15") pushbutton sign shall be installed above each pushbutton with the arrow pointing in the direction of the appropriate cross walk. When channel is used for mounting pushbutton signs the top sign bolt shall be tapped into the pole. Signs shall be in accordance with Division 70, Section 70.11 – Standard Signs.

Article 21.2 Measurement

New and relocated pedestrian pushbuttons will be measured as units, complete and in place, including all labor, equipment, signs, and other material to provide a complete and working unit. Measurement shall be for the actual number of existing pushbutton assemblies removed and relocated, and the actual number of new pushbutton assemblies installed. Pedestrian pushbutton signs shall not be measured separately, and shall be considered part of the pushbutton assembly.

Article 21.3 Basis of Payment

Payment for this Work shall be in accordance with Division 10, Section 10.07 - Measurement and Payment, and shall include full payment for all Work described in this Section.

Payment will be made under the following units:

ITEM	UNIT
Pedestrian Pushbutton Assembly	Each

SECTION 80.22 FLASHING BEACONS

Article 22.1 General

A. Beacons

1. Intersection Control and Hazard Beacons

Each beacon shall consist of one or more single section traffic signal heads, in accordance with the provisions in Section 80.19 - Signal Heads, with yellow or red LED modules as shown on the Drawings.

2. Warning Sign Beacons

Each Warning Sign Beacons shall consist of twelve inch (12") diameter yellow LED signal indications. The number of units, unit configuration and unit installation shall be as shown on the Drawings.

3. Speed Limit Sign Beacons

The 'SCHOOL SPEED LIMIT 20 WHEN FLASHING' (S5-1) sign beacon assembly shall consist of four (4) signal heads with eight inch (8") or twelve inch (12") diameter yellow LED signal indications as shown on the Drawings. They shall be mounted horizontally directly above the S5-1 sign. The two upper beacons shall be illuminated alternately and face oncoming traffic. The lower beacons shall face the opposite direction and be illuminated alternately also.

4. Mast Arm Mounted Sign Beacons

Each mast arm mounted sign beacon assembly shall consist of four (4) twelve inch (12") diameter yellow LED signal indications with backplates, and two signs of the type and size indicated on the plans. All signs and signals shall be mounted on the mast arm, with two (2) signals and one (1) sign facing each direction. Any two (2) signals facing the same directions shall be illuminated alternately. Signal heads shall meet the requirements of Section 80.19 - Signal Heads.

B. Control Unit

1. Flashing Beacon Control Unit

The Flashing Beacon Control Unit is to be used for the following: Intersection Control Beacons, Hazard Beacons and Crosswalk Warning Sign Beacons. Each control unit shall be a complete flasher cabinet assembly consisting of an On/Off switch, 15-ampere circuit breaker, surge protector, terminal blocks, flasher socket and NEMA flasher. The enclosure

shall be a NEMA Type 3R, and shall be provided with a right side hinged door with locking mechanism.

2. Speed Limit Sign Beacon Control Unit

Each control unit shall be a complete flasher cabinet assembly consisting of a 20-ampere circuit breaker, solid state surge protector, Radio Interference Suppressor, MOV (Metal Oxide Varistor) surge protector, thermostatically controlled incandescent cabinet light with door activated bypass switch, terminal blocks, flasher socket, NEMA flasher and digital time clock. The enclosure shall be a NEMA Type 3R, and shall be vented and provided with a right side hinged door with locking mechanism.

3. Speed Limit Sign Beacon With Push Button Actuated Warning Beacon Control Unit

Each control unit shall be a complete cabinet assembly consisting of a 20-ampere circuit breaker, solid state surge protector, radio interference suppressor, MOV (Metal Oxide Varistor) surge protector, thermostatically controlled incandescent cabinet light with door activated bypass switch, terminal blocks, flasher socket, NEMA flasher, digital time clock, analog timer and isolation relay. The enclosure shall be a NEMA Type 3R, and shall be vented and provided with a right side hinged door with locking mechanism.

4. Push Button Actuated Warning Beacon Control Unit.

Each control unit shall be a complete cabinet assembly consisting of a 20-ampere circuit breaker, solid state surge protector, Radio Interference Suppressor, MOV (Metal Oxide Varistor) surge protector, thermostatically controlled incandescent cabinet light with door activated bypass switch, terminal block, flasher socket, NEMA flasher, analog timer and isolation relay. The enclosure shall be a NEMA Type 3R, and shall be vented and provided with a right side hinged door with locking mechanism.

C. Control Unit Component Specification

Control unit shall be wired in accordance with the latest cabinet wiring diagram available from the Traffic Signal Electronics Foreman.

Terminal blocks shall be in accordance with Section 80.17 - Controller Assemblies, except that a single three- (3-) position Box Lug type terminal block capable of accepting three (3) No. 6 AWG wires for terminating power cables must be supplied in all control units.

Switches shall be 15 ampere, single-pole, 120 volt AC.

The Metal Oxide Varistor (MOV), surge protector shall be a V130PA20A.

The cabinet light fixture shall be an incandescent type porcelain lamp holder rated for 660W-250V AC/CA. The lamp shall be 75W.

Flasher socket shall be Cinch-Jones socket S-406-SB, or equivalent.

Flasher shall be a NEMA 2 circuit, solid state, rated at 15 amperes per circuit flasher.

Digital time clock shall be an RTC AP41, or equivalent as approved by the Traffic Signal Electronics Foreman. Clock to be supplied with Speed Limit Sign Beacon Control Unit and Speed Limit Sign Beacon With Push Button Actuated Warning Beacon Control Unit.

Control unit, complete with all cabinet components, shall be delivered to Traffic Signal Electronics Shop for testing, prior to installation in the field.

Isolation Relay shall be IDEC power relay model RR2P-U (AC120)

Timer shall be IDEC analog timer RTE-P2 AF20

All other components shall meet the requirements of Section 80.17 - Controller Assemblies.

Article 22.2 Measurement

Flashing beacons, flashing beacon control units, and flashing beacon control units with push button actuated control will be measured separately as units, complete and in place, including all labor, equipment, and material to provide a complete and working unit.

Article 22.3 Basis of Payment

Payment for this Work shall be in accordance with Division 10, Section 10.07 - Measurement and Payment, and shall include full payment for all Work described in this Section.

Payment shall be made under the following units:

ITEM	UNIT
Intersection Control Beacon	Each
Hazard Beacon	Each
Warning Sign Beacons	Each
Speed Limit Sign Beacon	Each
Mast Arm Mounted Sign Beacon	Each
Flashing Beacon Control Unit	Each
Speed Limit Sign Beacon Control Unit	Each
Push Button Actuated Warning Beacon Control Unit	Each
Speed Limit Sign Beacon with Push Button Actuated Warning Beacon Control Unit	Each

SECTION 80.23 LUMINAIRES

Article 23.1 General

Luminaires shall be of the type shown on the Drawings.

Article 23.2 Light Distribution

Furnish luminaires having standard I.E.S. light distribution patterns as specified in the Contract Documents.

Prior to installation, Contractor shall check the socket position in the luminaire to verify that it corresponds to the setting indicated in the instructions for the light distribution type shown on the Drawings.

Vertical light distribution shall be short (s), medium (m), or long (l).

Cutoff shall be cutoff (c), semi-cutoff (s), or non-cutoff (n).

Lateral light distribution shall be Type 1, Type 1-4 way, Type II, Type II-4 way, Type III or Type IV.

When cutoff fixtures are specified in the Special Provisions or shown on the Drawings, the optical assembly shall provide ninety-degree (90°) cutoff and shielding. The reflector shall be specifically designed to produce the specified ANSI and IES light distribution when used with one hundred fifty (150) through four hundred (400) watt high pressure sodium lamps. The fixture shall have a flat plate glass lens and no part of the lens shall project below the luminaire's metal housing.

Mast arm mounted luminaires shall be provided with slip-fitters designed for mounting on two-inch (2") standard pipe.

Contractor shall ensure all lenses are of the refractor type, and that the refractors are made of polycarbonate resin.

Contractor shall ensure the polycarbonate resin lenses are molded in a single piece. Contractor shall not use reworked compound whose properties have been impaired by previous molding operations. Contractor shall provide lenses free from cracks, blisters, burns and flow lines, furnished with the natural molded surface, uniform density throughout, free from air, gas, or moisture pockets, and uncured areas, as consistent with good manufacturing practice. Contractor shall provide transparent lenses having a clear bluish tint and produced from resin, which has been suitably ultraviolet stabilized to reduce the effects of ultraviolet radiation on their color properties. Resins used shall meet the requirements for the self-extinguishing classification of ASTM D 635. Resin shall have a minimum impact strength, Izod notched of twelve foot pounds per inch (12.0 ft. lbs./inch)

when tested in accordance with ASTM D 256, Method A, using a one-quarter by one-half inch (1/4" x 1/2") bar molded in accordance with ASTM-recommended practice.

The Contractor shall furnish a certificate of compliance from the lens fabricator that all requirements contained in the paragraph above have been met.

The refractor shall be mounted in a doorframe assembly which shall be hinged to the luminaire at the house side and fastened at the street side by means of an automatic type latch.

The refractor and doorframe assembly shall be forced upward at the street side by spring pressure, against the gasket seat, when in the closed and latched position.

All gaskets shall be composed of a material capable of withstanding the temperature involved and they shall be securely held in place.

All parts of the luminaire shall be manufactured from corrosion-resistant materials.

Manufacturer's luminaire specifications, shop drawings, and photometric data shall be submitted and approved before installing any luminaire on the project.

Article 23.3 Measurement

Luminaires will be measured as units complete and in place, including all labor, equipment, and materials to provide a complete and functioning unit. No measurement for payment will be made until the functional test has been completed in accordance with Section 80.16, Article 16.2 – Field Tests.

Article 23.4 Basis of Payment

Payment for this Work shall be in accordance with Division 10, Section 10.07 - Measurement and Payment, and shall include full payment for all Work described in this Section.

Payment will be made under the following units:

ITEM	UNIT
Luminaire (Type) (Wattage/Lumens) (Vertical) (Cutoff) (Lateral)	Each

SECTION 80.24 BALLASTS

Article 24.1 General

Ballasts for high-intensity discharge lamps shall be an integral part of each luminaire and designed for the voltages and lamp types specified in the Drawings or Special Provisions. The current needed to start the lamps shall be less than the operating current.

Ballasts shall be the regulator type with copper windings electrically isolated from each other, and shall start and operate the lamps in temperatures down to -40°F. The allowable line voltage variation shall be at least plus and minus ten percent (10%).

High pressure sodium luminaires, except those with 1000 watt lamps, shall be equipped with magnetic regulator ballasts with the following additional operating characteristics:

1. The lamp wattage regulation spread at any time over the life of the lamp shall not exceed eighteen percent (18%) of nominal lamp watts at plus or minus ten percent ($\pm 10\%$) line voltage variations.
2. With nominal line and lamp voltages, the ballast shall regulate the lamp output to within five percent (5%) of the ballast design center, and sustain lamp operation with a minimum sixty percent (60%) voltage drop lasting four (4) seconds or less.
3. Grounded socket shell.

Luminaires with 1000 watt high pressure sodium lamps shall be equipped with auto-regulator ballasts that provide a maximum thirty percent (30%) lamp regulation spread, a minimum thirty-five percent (35%) voltage dip tolerance, and with nominal line and lamp voltages regulate lamp output to within five percent (5%) of the ballast design center.

Ballasts for use for soffit luminaires shall be furnished with mounting brackets attached and shall be equipped with terminal blocks for primary connections and lamp socket preconnected to the secondary for flush mounted luminaires and with terminal blocks for both primary and secondary connections for use with suspended luminaires.

The Contractor shall submit the ballast manufacturer's volt-watt trace and specification sheets to the Street Light Maintenance Supervisor for review and approval.

Article 24.2 Measurement

This item shall be considered incidental to other Work.

Article 24.3 Basis of Payment

No separate pay item will be allowed for this item.

SECTION 80.25 FALSEWORK LIGHTING

Article 25.1 General

When required by the Special Provisions, falsework lighting shall be installed where vehicular traffic with or without pedestrian traffic crosses through or under structure falsework.

Illumination of the portal faces of falsework shall be provided during the hours from dusk to dawn. Illumination of the pavement and pedestrian openings through or under falsework shall be provided twenty four (24) hours per day.

The Contractor shall submit a plan of the proposed lighting installations and shall not commence falsework construction until such Drawings have been reviewed by the Engineer. A subsequent review shall be made by the Engineer after falsework lights have been placed in operation.

Fixtures for illumination of roadway pavement between entrances and exit portals shall be enclosed in units with protective cover lens.

Fixture housing shall be heavy gauge, anodized aluminum and shall have an etched, anodized aluminum reflecting surface, or equivalent. Beam spread shall be between one hundred (100) and one hundred thirty (130) degrees.

Fixtures shall be equipped with high temperature glazed porcelain medium base sockets and six foot (6') conductors for splicing, approved by UL for outdoor use.

Fixtures shall be fully adjustable with bracket and locking screws on a mounting plate and shall provide mounting directly to a standard metal junction box.

Fixtures for pedestrian passageways shall be porcelain box receptacles mounted on standard metal junction boxes and equipped with wire lamp guards. Porcelain box receptacles shall be rated at six hundred sixty (660) watts, two hundred fifty (250) volts. Wire lamp guards shall be made of No. 10 AWG wire and shall be suitable for general construction work.

Lamps shall be of the medium base incandescent type. For pavement illumination, lamps shall be one hundred fifty (150) watts minimum. For pedestrian passageway illumination, lamps shall be one hundred (100) watts minimum.

The face of all falsework and forms located within or adjacent to the traveled way, on the approach side, shall be fully illuminated by a minimum of four (4) three hundred (300) watt PAR reflector flood lights directed upon the vertical and horizontal supports. The lights shall be located a minimum of ten feet (10') and a maximum of fifteen feet (15') from the portal faces adjacent to the traveled way and mounted a minimum of twelve feet (12') and a maximum of fifteen feet (15') high. When a median area contains falsework, a minimum of one (1) additional three hundred (300) watt PAR reflector flood light shall be installed in

the same manner to illuminate the median support. Each flood light shall be aimed in such a manner as to preclude glare to oncoming motorists. Floodlights shall be mounted on temporary wood poles set in the ground and located on both sides of the traveled way.

For illumination of roadway pavement between entrance and exit portals, a continuous row of fixtures shall be installed over the center of each lane beneath the falsework structure at intervals of not more than fifteen feet (15') , with the end fixtures not further than seven feet (7') inside the portal faces. Mounting height of fixtures over the pavement shall be as directed.

Pedestrian openings, through or under falsework, shall be illuminated with fixtures centered over the passageway at intervals of not more than fifteen feet (15') , with the end fixtures not more than seven feet (7') inside the portal faces and at a height of ten feet (10'), unless otherwise directed.

For roadway pavement and portal face illumination, No. 12 AWG conductors with Type XHHW insulation shall be used. For pedestrian passageways, conductors shall be No. 12 AWG and enclosed in a one-half inch(1/2") unpainted, zinc-coated metallic conduit.

Contractor shall provide two branch circuits. Pedestrian passageway lights and roadway pavement lights shall be on one (1) circuit and portal face floodlights shall be on a separate circuit. Each branch circuit shall be fused, not to exceed twenty (20) amperes.

The above-specified portal lighting shall be installed on the day that vertical supports are erected and before traffic is permitted to pass between these supports during the hours from dusk to dawn. The other falsework lights shall be installed as soon as the members on which they are to be supported are in place.

Upon completion of the project or when directed, falsework lighting equipment shall remain the property of the Contractor and shall be removed from the site of the Work.

Article 25.2 Measurement

Falsework lighting for each location will be measured as one lot, installed complete, including all labor, equipment, and material required to provide a complete and functioning system.

Article 25.3 Basis of Payment

Payment for this Work shall be in accordance with Division 10, Section 10.07 - Measurement and Payment, and shall include full payment for all Work described in this Section.

Payment will be made under the following units:

ITEM	UNIT
Falsework Lighting	Lot

SECTION 80.26 INTERCONNECT CABINET

Article 26.1 General

Install the interconnect cable termination cabinet when called for in the Drawings or when three (3) or more interconnect cables terminate at the controller location. All cables shall be terminated in the interconnect cable cabinet and none in the controller cabinet.

Furnish an in interconnect termination cabinet that:

1. Is constructed from 16 gauge galvanized steel with an ANSI 61 gray polyester powder coat inside and out.
2. Meets NEMA Standards for Type 3R enclosures.
3. Has a 16-gauge galvanized steel continuous hinge with stainless steel pin.
4. Has a cover fastened securely with captive plated steel screws.
5. Is provided with a hasp and staple for padlocking.
6. Has no gasketing or knockouts.
7. Has no ventilating cover or louvers.
8. Has a standoff mounted back panel with grounding lug assembly.
9. Provide two Type 66 B3-50 terminal blocks to Traffic Signal Electronics personnel, who will install the terminal blocks.

Article 26.2 Measurement

Interconnect cabinets will be measured as units installed complete and in place, including all labor, equipment, and material to provide a complete and functioning unit.

Article 26.3 Basis of Payment

Payment for this Work shall be in accordance with Division 10, Section 10.07 - Measurement and Payment, and shall include full payment for all Work described in this Section.

Payment will be made under the following units:

ITEM	UNIT
Interconnect Cabinet	Each

SECTION 80.27 PROTECTIVE POST ASSEMBLY

Article 27.1 General

Protective post assembly shall be a concrete-filled Schedule 40, steel pipe installed in accordance with the appropriate Standard Details.

Article 27.2 Measurement

Protective post assembly will be measured as units installed complete and in place, including all labor, equipment, and material to provide a complete and functioning unit.

Article 27.3 Basis of Payment

Payment for this Work shall be in accordance with Division 10, Section 10.07 - Measurement and Payment, and shall include full payment for all Work described in this Section.

Payment will be made under the following units:

ITEM	UNIT
Protective Post Assembly	Each

SECTION 80.28 SALVAGING ELECTRICAL EQUIPMENT

Article 28.1 General

Unless otherwise specified or shown on the Drawings or Specifications, existing electrical equipment including but not limited to: luminaires, standards, mast arms, poles, caps, handhole covers, mounting bolts, controllers, cabinets, optical detectors, signal heads, pedestrian heads, service equipment, and junction box lids shall be salvaged and delivered to the Municipality of Anchorage Electronics Warehouse or the Municipality of Anchorage Pole Yard to be placed as directed by the Traffic Engineer.

Traffic Signal Electronics personnel and Street Light Maintenance personnel will be allowed to select the equipment and pole/arm items they would like to salvage. Contractor is responsible for disposal of all remaining items. All poles and arms not selected for salvage shall have the pole plate or arm plate cut off to render the item unusable.

Contractor shall contact the Traffic Signal Electronics Shop Foreman, at 343-8355, one week prior to the tentative delivery date.

Salvaged poles and mast arms shall be stripped of all wire and hardware and any damaged areas, and exposed hole edges shall be cleaned and painted with cold galvanizing paint in accordance with Section 80.16, Article 16.3 - Galvanizing. All caps, hand-hole covers, mast arms and mounting bolts shall be returned with the pole.

Removal, wire and hardware stripping, listed cleaning and cold galvanize painting, and delivery of all salvaged electrical equipment shall be considered incidental to the Contract and no separate payment shall be made.

When a controller assembly is to be salvaged, the salvage material shall include timing modules, switches, detector control units, conflict monitor unit, and all other equipment contained in the controller cabinet prior to award of the Contract.

Care shall be exercised in removing and salvaging electrical equipment so that it will remain in its original form and existing condition. The Contractor will be required to replace, at his expense, any of the above-mentioned electrical equipment which has been damaged or destroyed by his operations.

Unless otherwise specified, underground conduit, conductors, foundations and detectors not reused shall become the property of the Contractor and shall be removed from the project right-of-way. If said materials do not interfere with other construction, they may, with approval from the Engineer, be abandoned in place except that conductors must be removed from conduit prior to abandonment. Foundations abandoned in place shall conform to the requirements of Section 80.03 – Removing and Replacing Improvements.

Holes formed by removing pull boxes and foundations shall be filled with material equivalent to the original and compacted to the same density as the surrounding material.

When existing electrical equipment is to be reused, the Contractor shall furnish and install all necessary materials and equipment, including signal mounting brackets, anchor bolts, nuts, washers and concrete as required to complete the new installation.

All traffic signal, flashing beacon and lighting fixtures to be reinstalled shall be cleaned, relamped, and reconditioned in accordance with Section 80.16, Article 16.4 – Painting for Steel Structures.

Salvaged materials required to be reused and found to be unsatisfactory by the Engineer shall be replaced by new material and the cost will be paid as extra Work as provided in Division 10, Sections 10.05 – Control of Work and 10.07 – Measurement and Payment.

Article 28.2 Measurement

Measurement for removal of poles in this Section is per each unit removed; and includes all work and materials necessary to remove poles, hardware disposal, cutting poles to render them unusable, disassemble, salvage, disposal, and delivery to the Municipality of Anchorage Pole Yard as specified in the Drawings or in the Special Provisions. When Drawings are unclear as to the method of pole salvage or disposal, the Contractor shall contact the Traffic Engineer to receive specific instructions.

Removal of the pole foundation, in accordance with Section 80.03 - Removal and Replacing Improvements, and disposal of the pole foundation is incidental to the pay items in this Section. Salvage and delivery of existing signs, signal hardware and illumination hardware shall also be considered incidental to the pole removal pay items.

If Owner declines ownership, the poles, mast arms, and associated hardware become Contractor property.

Article 28.3 Basis of Payment

Payment for this Work shall be in accordance with Division 10, Section 10.07 - Measurement and Payment, and shall include full payment for all Work described in this Section.

Payment will be made under the following units:

ITEM	UNIT
Remove Luminaire Pole	Each
Remove Signal Mast Arm or Combination Pole	Each
Remove Signal Pedestal or Pedestrian Pushbutton Pole	Each

**MUNICIPALITY OF ANCHORAGE
STANDARD SPECIFICATIONS**

**DIVISION 80
TRAFFIC SIGNALS AND ILLUMINATION
STANDARD DETAILS**

**STANDARD CONSTRUCTION SPECIFICATIONS
MISCELLANEOUS
DIVISION 80
INDEX OF STANDARD DETAILS**

80-1	Saw Cut Trench
80-2	Concrete Foundation Load Center Type 1A
80-3	Concrete Foundation Load Center Type 1
80-4	Concrete Foundation Type 1 Load Center Section AA
80-5	Controller Cabinet Foundation Type "P" or "R"
80-6	Concrete Foundation for Type "P" or "R" Controller Section AA
80-7	Concrete Foundation for Type "P" or "R" Controller Section BB
80-8	Vault Type "M" Controller Cabinet Foundation
80-9	Poured Concrete Luminaire Pole Foundation
80-10	Poured Concrete Foundation Signal Mast Arm Pole
80-11	Poured Concrete Spread Footing Signal Pole Foundation
80-12	Concrete Foundations for Signal Pedestal Pole and Pedestrian Push Button Pole
80-13	Driven Steel Pile Light Pole Foundation
80-14	Driven Steel Pile Signal Pole Foundation
80-15	Pedestrian Push Button Pole
80-16	Signal Pedestal Pole
80-17	Pedestal Signal Pole Slip-Base and Adapter Detail
80-18	Direct Imbedded Luminaire Pole
80-19	Flange-Mounted Luminaire Pole
80-20	Luminaire Arm Detail
80-21	Driven Steel Pipe Slip Base Pole Assembly
80-22	Flange-Mounted Detail for Concrete Luminaire Base
80-23	Concrete Luminaire Base Slip-Base Detail
80-24	Signal Mast Arm Pole and Combination Signal/Luminaire Pole
80-25	Signal Mast Arm/Pole Design Loading
80-26	Details-Signal Mast Arm Pole and Signal/Luminaire Pole
80-27	Side-Mounted Signal Details
80-28	Pedestrian Push Button Assembly
80-29	Post Top and Mast Arm Mounted Signal Details
80-30	Type I Junction Box
80-31	Type IA Junction Box
80-32	Type II Junction Box

80-33	Type III Junction Box
80-34	Post Mounted Load Center - Type 3
80-35	Post Mounted Load Center - Type 2
80-36	Pad Mounted Load Center - Type 1A
80-37	Pad Mounted Load Center - Type 1
80-38	Load Center Wiring Diagram "A"
80-39	Panel Schedule for Wiring Diagram "A"
80-40	Load Center Wiring Diagram "B"
80-41	Panel Schedule for Wiring Diagram "B"
80-42	Load Center Wiring Diagram "C"
80-43	Panel Schedule for Wiring Diagram "C"
80-44	Load Center Wiring Diagram "D"
80-45	Panel Schedule for Wiring Diagram "D"
80-46	Load Center Wiring Diagram "E"
80-47	Panel Schedule for Wiring Diagram "E"
80-48	Load Center Wiring Diagram "F"
80-49	Panel Schedule for Wiring Diagram "F"
80-50	Load Center Wiring Diagram "G"
80-51	Panel Schedule for Wiring Diagram "G"
80-52	Conduit Encased Loop Detector
80-53	Loop Detector Installation Details
80-54	Loop Detector Home Run
80-55	Opticom Detector Installation Details
80-56	Signal Heads
80-57	Speed Limit Sign Beacon
80-58	Mast Arm Mounted Sign Beacons
80-59	Warning Sign Beacon
80-60	Splice Detail Loop Detector Leads
80-61	Signal Head Wiring Details
80-62	Interconnect Cable Termination Cabinet
80-63	Protective Post Assembly

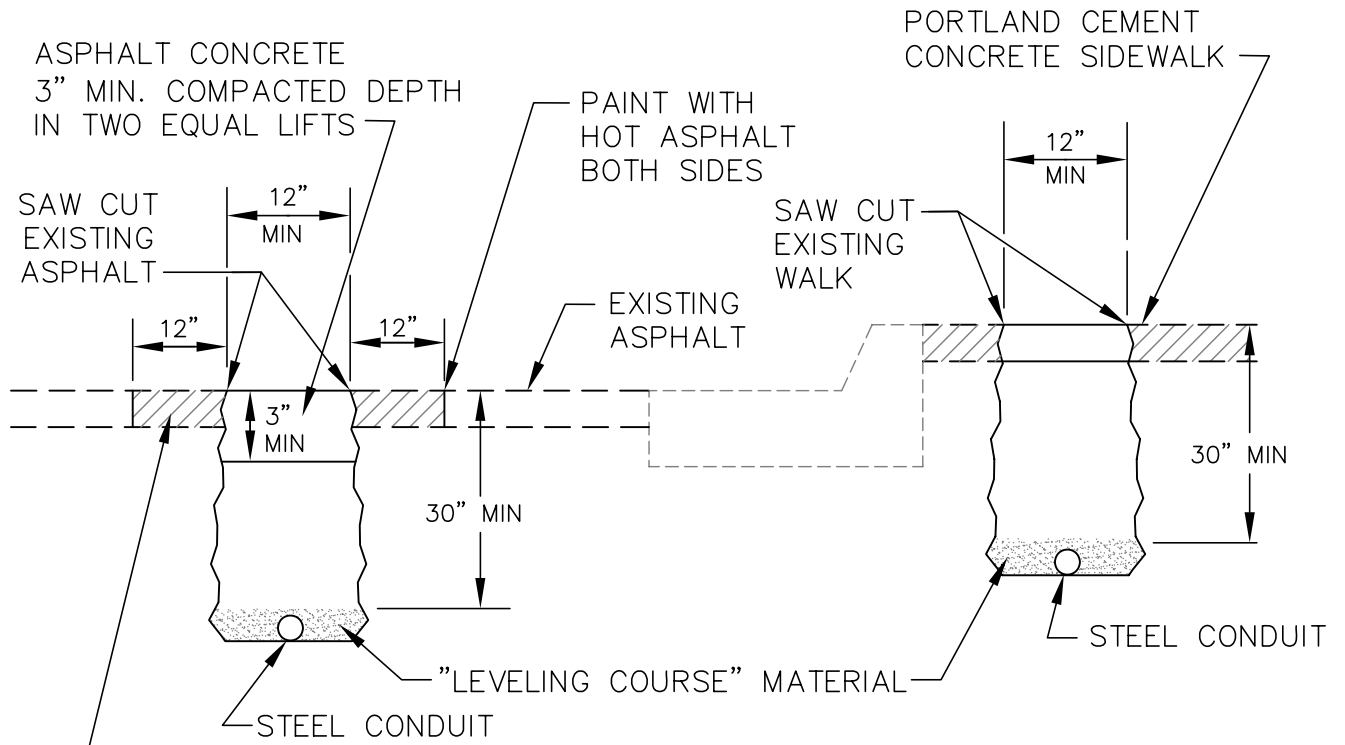

AFTER TRENCH BACKFILL HAS BEEN COMPACTED AN ADDITIONAL 12" OF ASPHALT WILL BE REMOVED FROM EACH EDGE OF THE ORIGINAL CUT. THE ENGINEER MAY REQUIRE MORE THAN A 12" ADDITIONAL CUT IF THE EXISTING PAVEMENT HAS BEEN LIFTED IN THE REMOVAL PROCESS OR IF THE JOINT DOES NOT OCCUR ON UNDISTURBED MATERIAL.

MUNICIPALITY



OF ANCHORAGE

SCALE:
NTS

APPROVED:

REVISED:
10/07

SAW CUT TRENCH

SECTION #
80.02

DETAIL #
80-1

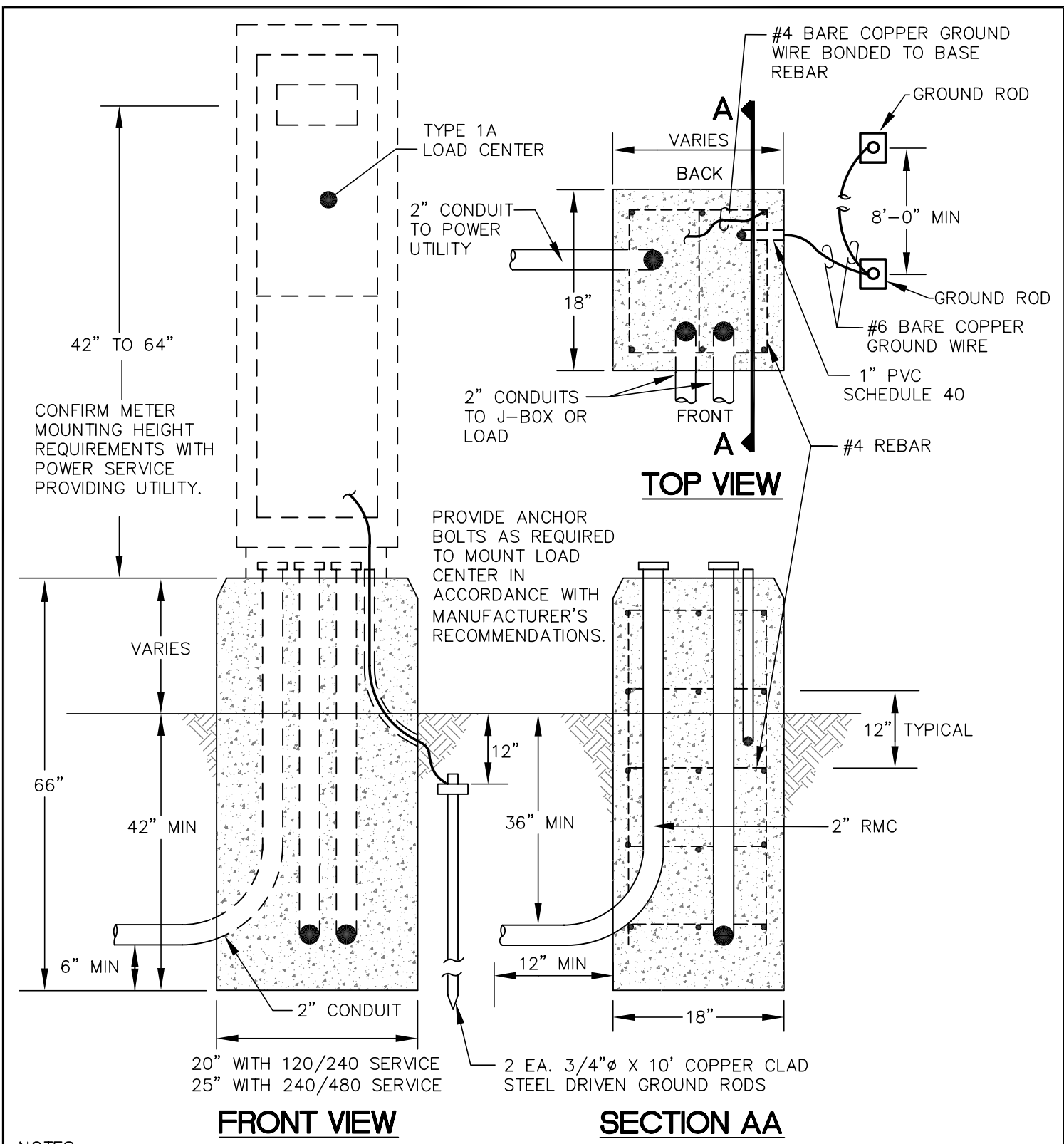

NOTES:

1. ORIENTATION OF CONDUIT SWEEPS IS REPRESENTATIVE. CONTRACTOR SHALL COORDINATE CONDUIT ORIENTATION WITH THE ENGINEER AND UTILITY.
2. PROVIDE NON-FROST SUSCEPTIBLE COMPACTED BACKFILL.
3. INSTALL TYPE 1A OR TYPE 2 JUNCTION BOX ADJACENT TO LOAD CENTER FOUNDATION. JUNCTION BOX SIZE TO BE DETERMINED USING THE LATEST VERSION OF MOA DESIGN CRITERIA MANUAL, CHAPTER 6.

 MUNICIPALITY OF ANCHORAGE	SCALE: NTS APPROVED: REVISED: 5/08	<h1 style="margin: 0;">CONCRETE FOUNDATION LOAD CENTER TYPE 1A</h1>	SECTION # 80.04 DETAIL # 80-2
---	--	---	--

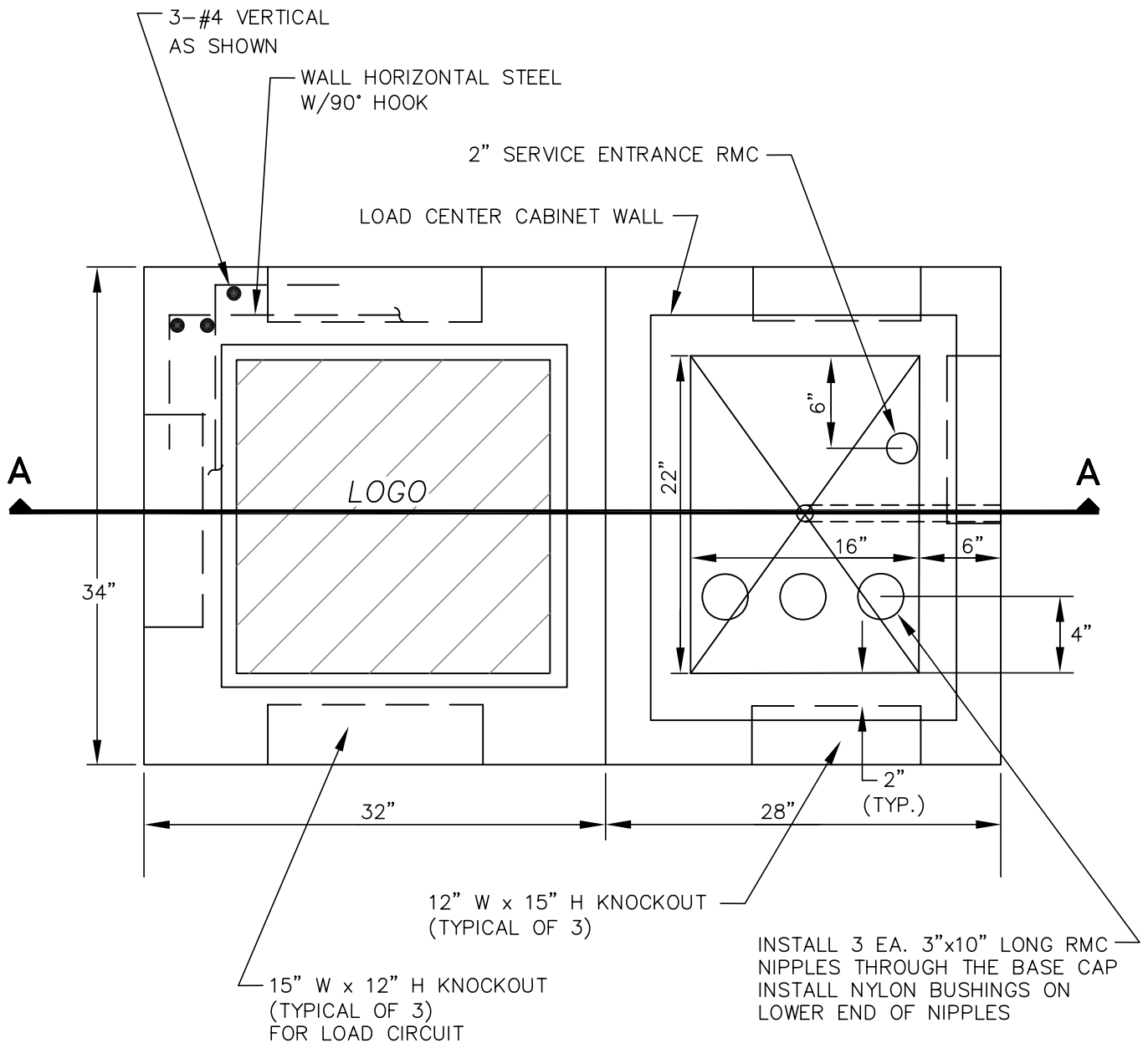

PLAN VIEW

NOTE:

1. SEE DETAIL 80-4 FOR SECTION AA.

MUNICIPALITY



OF ANCHORAGE

SCALE:
NTS

APPROVED:

REVISED:
5/08

**CONCRETE FOUNDATION
LOAD CENTER
TYPE 1**

SECTION #
80.04

DETAIL #
80-3

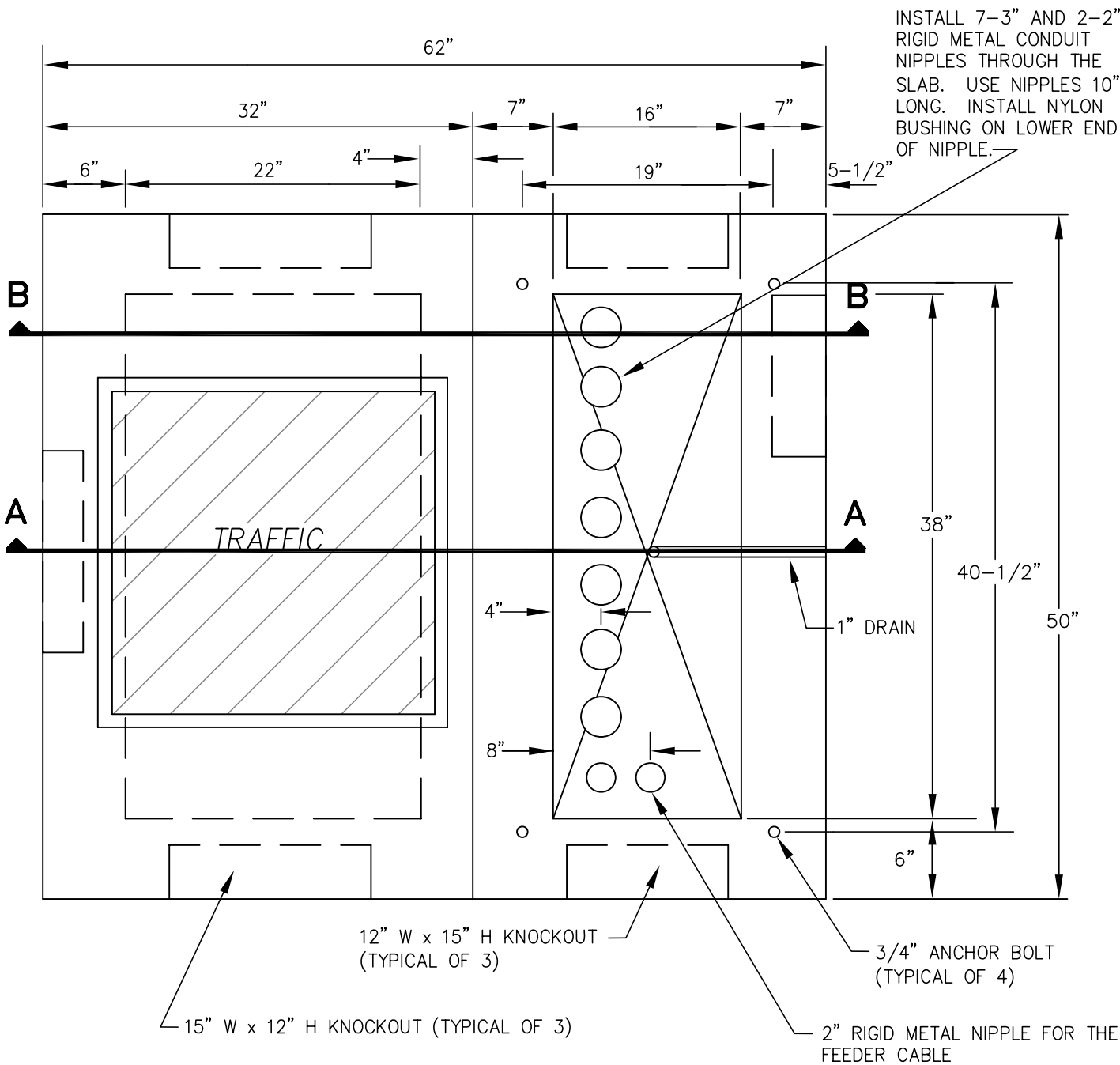

PLAN VIEW

NOTES:

1. SEE STANDARD DETAIL 80-6 FOR SECTION AA
2. SEE STANDARD DETAIL 80-7 FOR SECTION BB.
3. ANCHOR BOLTS SHALL NOT PROTRUDE MORE THAN 1-1/2" ABOVE THE TOP OF THE FOUNDATION. USE CABINET MANUFACTURER SPECIFIED ANCHOR BOLT DIMENSIONS.
4. SEAL UNUSED CONDUIT STUBS WITH WATERTIGHT CAPS.

 MUNICIPALITY OF ANCHORAGE	SCALE: NTS APPROVED: REVISED: 5/08	<h1 style="margin: 0;">CONTROLLER CABINET FOUNDATION TYPE "P" OR "R"</h1>	SECTION # 80.04 DETAIL # 80-5
---	--	---	--

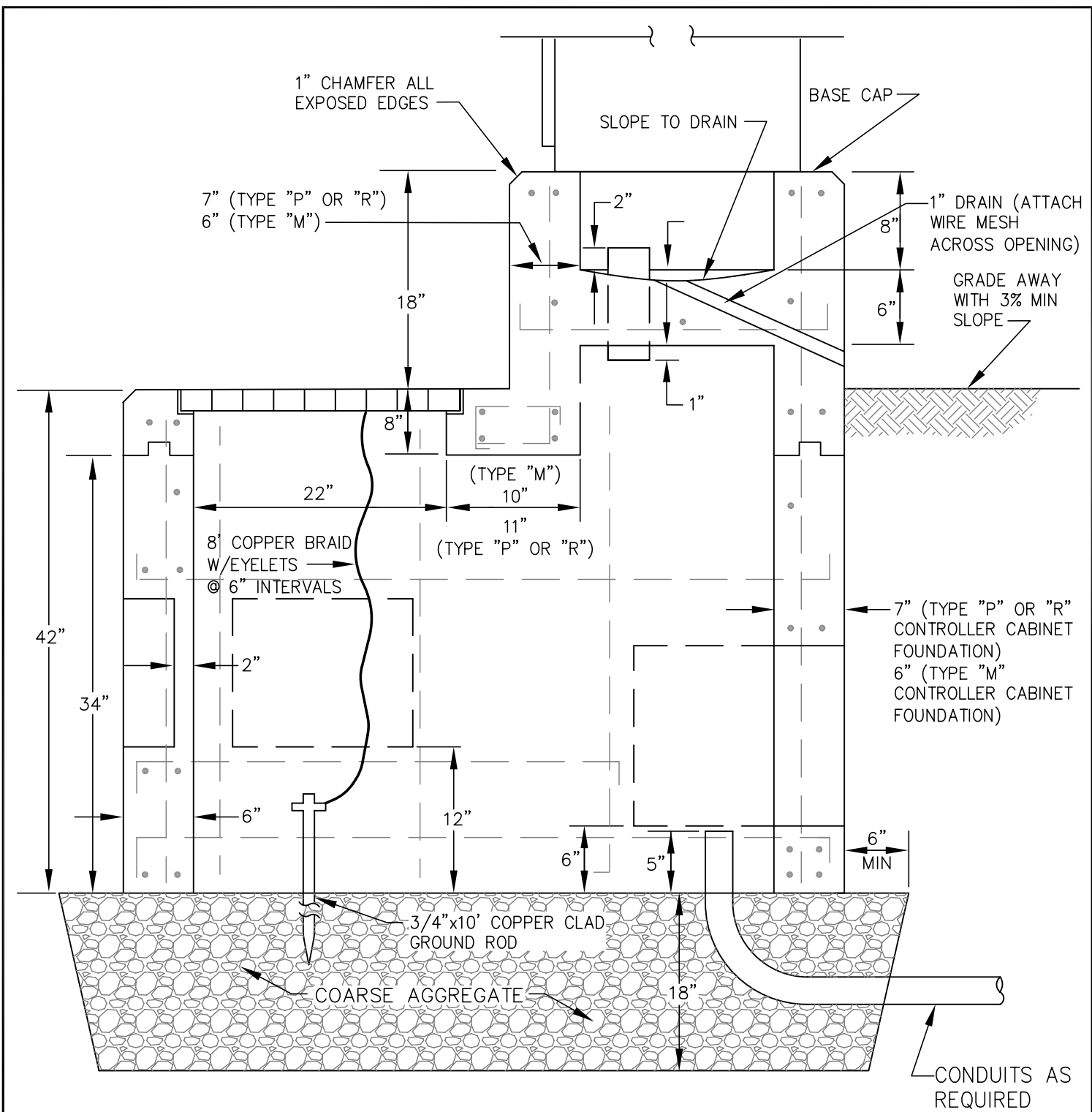

SECTION AA

NOTE:
SEE STANDARD DETAIL 80-7, SECTION BB, FOR REBAR DETAILS.

 <p>MUNICIPALITY OF ANCHORAGE</p>	<p>SCALE: NTS</p> <p>APPROVED:</p> <p>REVISED: 5/08</p>	<p>CONCRETE FOUNDATION TYPE "P" OR "R" CONTROLLER SECTION AA</p>	<p>SECTION # 80.04</p> <p>DETAIL # 80-6</p>
--	---	---	---

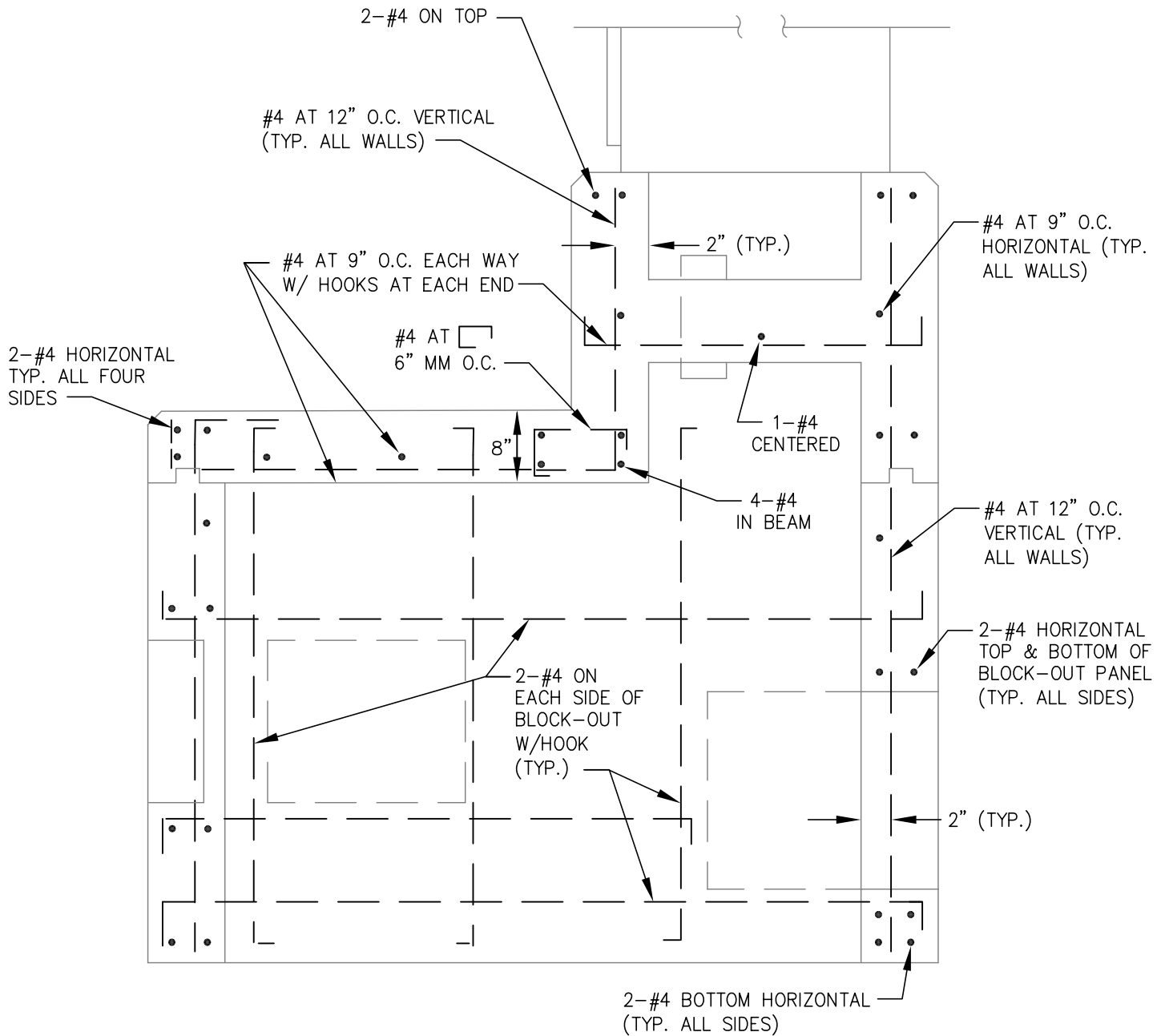

SECTION BB

NOTE:

STOP HORIZONTAL & VERTICAL STEEL AT THE BLOCK-OUT PANELS & THE JOINT USING 90 DEGREE HOOKS. USE 2 EXTRA #4 HORIZONTAL & VERTICAL BARS ALL SIDES AS SHOWN.

MUNICIPALITY

 OF ANCHORAGE

SCALE:
NTS
 APPROVED:
 REVISED:
5/08

CONCRETE FOUNDATION TYPE "P" OR "R" CONTROLLER SECTION BB

SECTION #
80.04
 DETAIL #
80-7

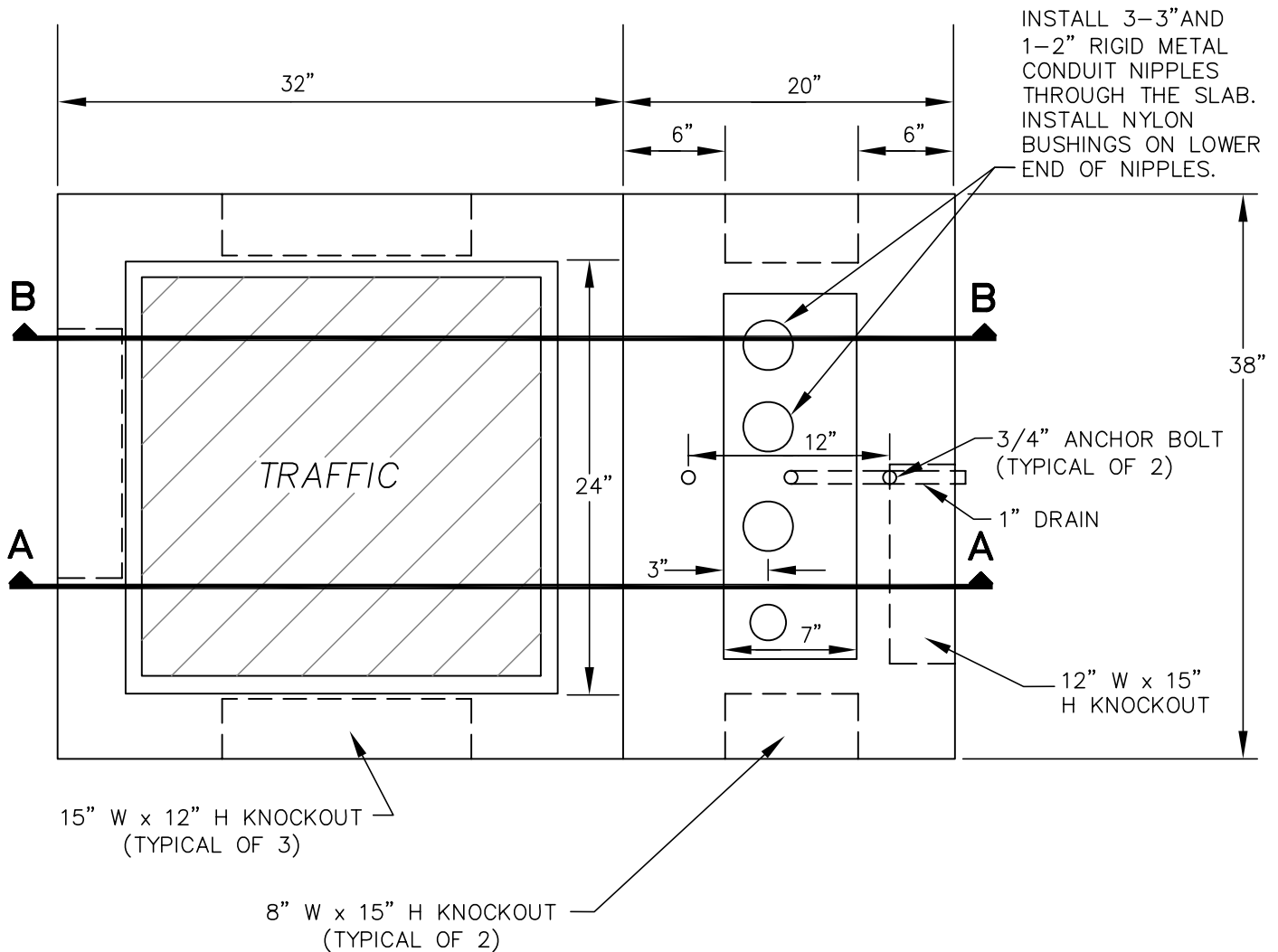

PLAN VIEW

NOTES:

1. SEE DETAIL 80-6 FOR SECTION AA.
2. SEE DETAIL 80-7 FOR SECTION BB.
3. ANCHOR BOLTS SHALL NOT PROTRUDE MORE THAN 1-1/2" ABOVE THE TOP OF THE FOUNDATION. USE CABINET MANUFACTURER SPECIFIED ANCHOR BOLT DIMENSIONS.
4. SEAL UNUSED CONDUIT STUBS WITH WATERTIGHT CAPS.

MUNICIPALITY



OF ANCHORAGE

SCALE:
NTS

APPROVED:

REVISED:
5/08

VAULT TYPE "M" CONTROLLER CABINET FOUNDATION

SECTION #
80.04

DETAIL #
80-8

EDGE OF TRAVELED WAY FOR SLIP BASE

3 EA. 7/8"x36" STEEL PLATE ANCHOR BOLTS ON 14" BOLT CIRCLE (SEE DETAIL)

EDGE OF TRAVELED WAY FOR FLANGE BASE

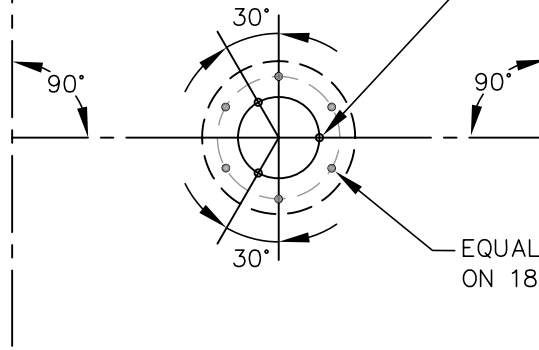

EQUALLY SPACED 6-#8 BARS ON 18-3/4" DIAM.

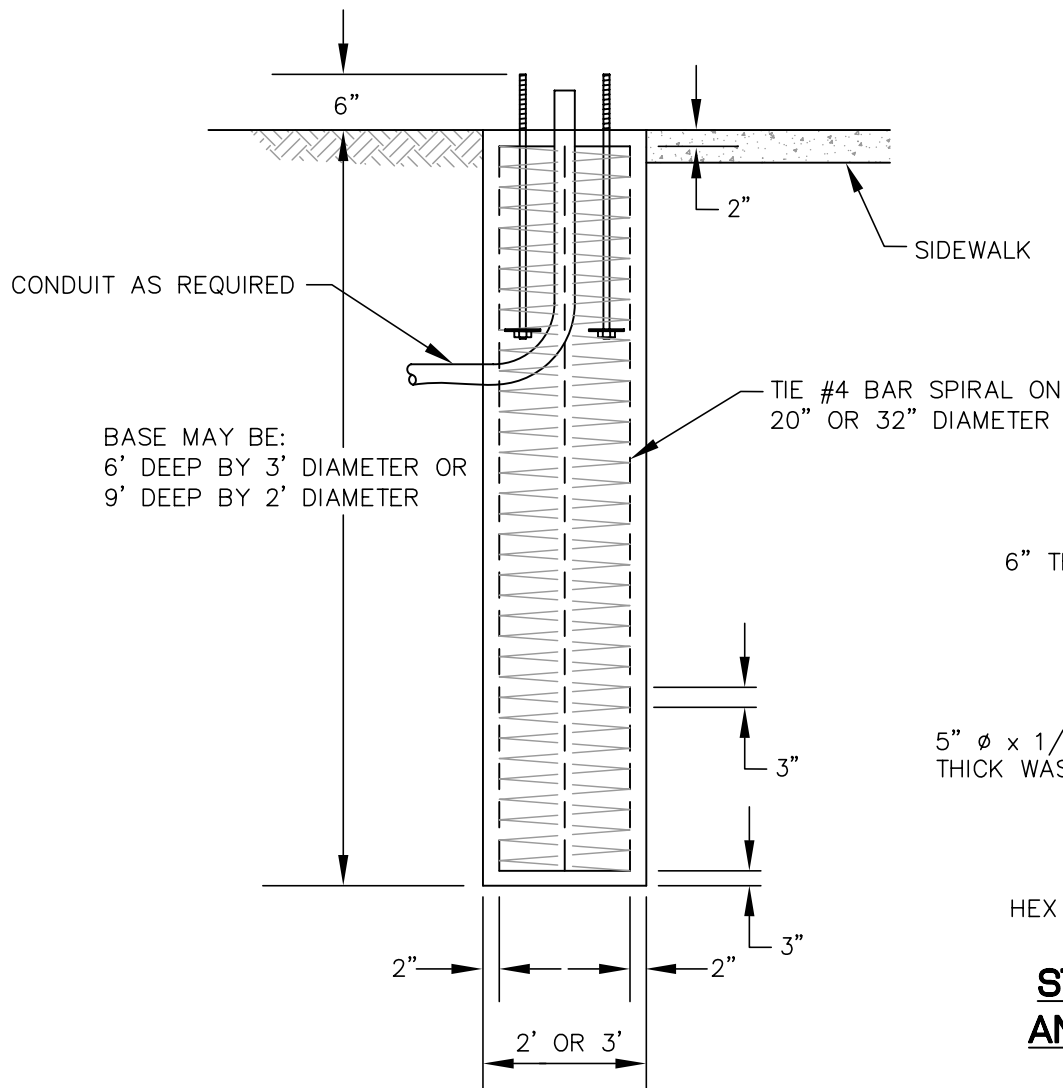

CONDUIT AS REQUIRED

BASE MAY BE:
6' DEEP BY 3' DIAMETER OR
9' DEEP BY 2' DIAMETER

TIE #4 BAR SPIRAL ON
20" OR 32" DIAMETER

6" THREADED

5" ϕ x 1/4" THICK WASHER

HEX NUT

STEEL PLATE ANCHOR BOLT

REVISION: 12/09 FIXED REBAR REFERENCE FOR SPIRAL



SCALE:
NTS

APPROVED:

REVISED:
12/09

**POURED CONCRETE
LUMINAIRE POLE
FOUNDATION**

SECTION #
80.04

DETAIL #
80-9

22" DIA. BOLT CIRCLE
2"x84"x6" ANCHOR
BOLTS TO BE THREADED
A MIN. OF 8"

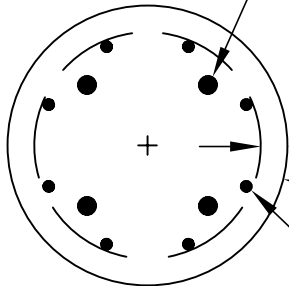

SECTION AA

TERMINATE CONDUITS 4" ABOVE FOUNDATION TOP
GROUNDING BUSHING
BOND ALL CONDUITS AND STEEL POLE WITH NO. 8 BARE CU BONDING WIRE

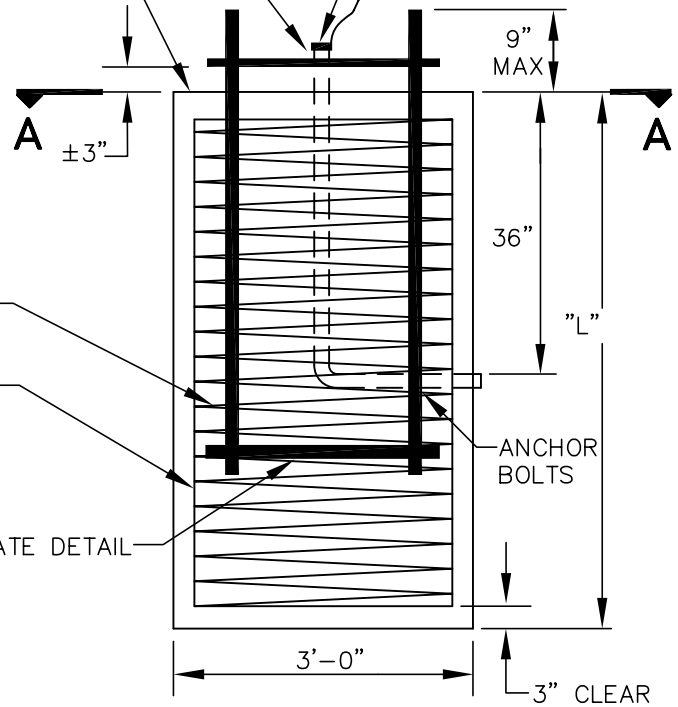

FOUNDATION DETAIL

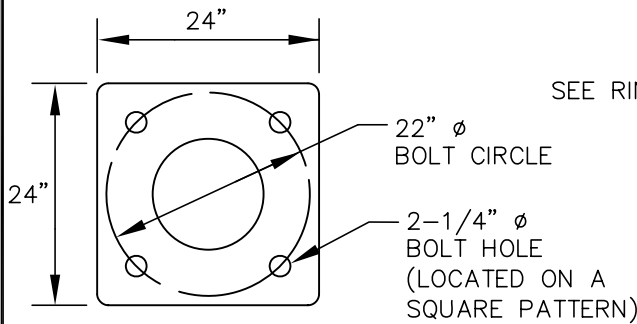

BASE PLATE DETAIL

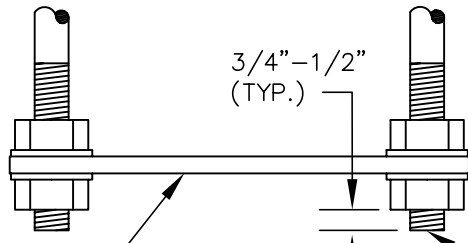

RING PLATE
25" O.D. X 17" I.D. X 1" THICK

RING PLATE DETAIL

SINGLE ARMS ≤ 40', L=9'-0"
SINGLE ARMS OVER 40' AND ≤ 60', L=12'-0"
DUAL MAST ARM BOTH ≤ 30', L=9'-0" DUAL
SEE NOTE 8 FOR ALL OTHERS

FOUNDATION DETAIL FOR GRANULAR SOILS, FREE OF ORGANICS & DEBRIS. FOR OTHER CONDITIONS, PROVIDE A FOUNDATION INVESTIGATION TO DETERMINE IMBEDMENT DEPTH AND ADEQUACY OF DESIGN.

TYPICAL ANCHOR BOLT WITH
4 HEAVY HEX NUTS AND
4 STANDARD HARDENED WASHERS
(UNC THREAD SERIES)

NOTES:

- ANCHOR BOLTS SHALL CONFORM TO ASTM F1554, WITH GRADE AS SPECIFIED BY THE MANUFACTURER.
- REINFORCING STEEL SHALL CONFORM TO ASTM A615, GRADE 60 FOR DEFORMED BARS OF BILLET STEEL.
- EACH SPIRAL REBAR UNIT WITHIN EACH FOOTING SHALL HAVE 1-1/2 TURNS OF THE REBAR AT EACH END OF THE UNIT.
- GALVANIZING OF ANCHOR BOLTS, NUTS, AND WASHERS SHALL CONFORM TO ASTM A153.
- STEEL ANCHOR PLATES SHALL CONFORM TO ASTM A36.
- TOP OF CONCRETE FOUNDATION SHALL HAVE A BROOMED FINISH.
- REFERENCE TOP BACK OF CURB IN ESTABLISHING FOUNDATION TOP ELEVATION. TOP OF FOUNDATION SHALL BE FLUSH WITH SIDEWALK/PAVING FINISH GRADE OR 2"-4" ABOVE FINISH GROUND ELEVATION.
- SINGLE MAST ARMS OVER 60' OR DUAL MAST ARMS WITH ONE OR BOTH ARM(S) OVER 30' REQUIRE PROJECT SPECIFIC FOUNDATION DESIGN AND SHALL BE CONSTRUCTED AS SHOWN ON THE DRAWINGS.

REVISION: 12/09 EDITED NOTE TOP LEFT CORNER TO SIMPLIFY BOLT REQUIREMENT

MUNICIPALITY



OF ANCHORAGE

SCALE:
NTS

APPROVED:

REVISED:
12/09

**POURED CONCRETE
FOUNDATION SIGNAL
MAST ARM POLE**

SECTION #
80.04

DETAIL #
80-10

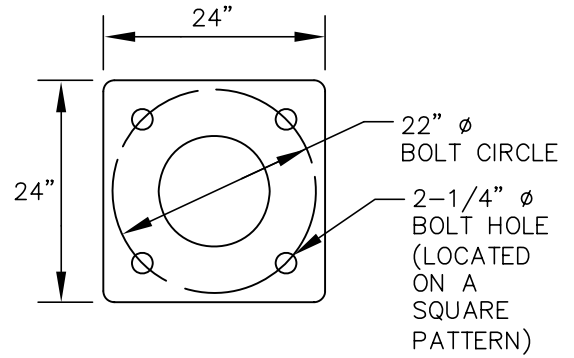
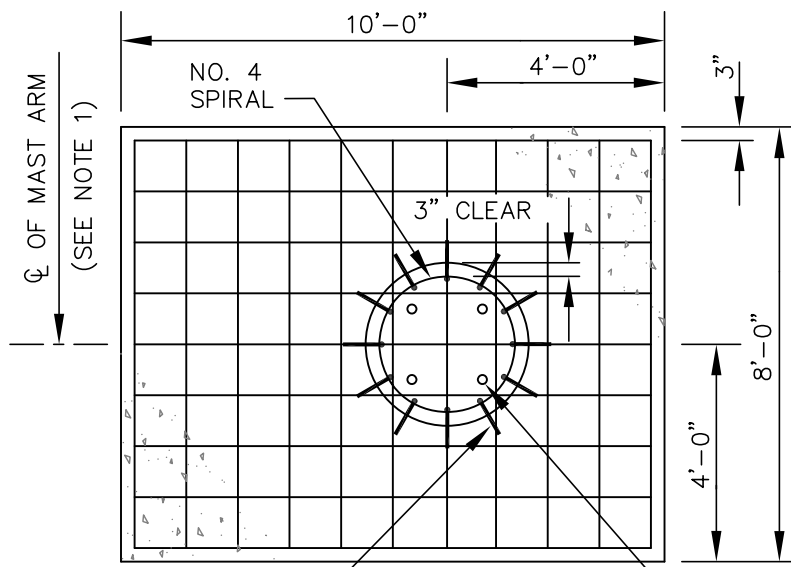

BASE PLATE DETAIL

NO. 8 BARS
EVENLY SPACED

PLAN VIEW

(4) 2"x64" ANCHOR BOLTS WITH
(4) HEX NUTS AND (4) WASHERS PER BOLT
(UNC THREAD SERIES)

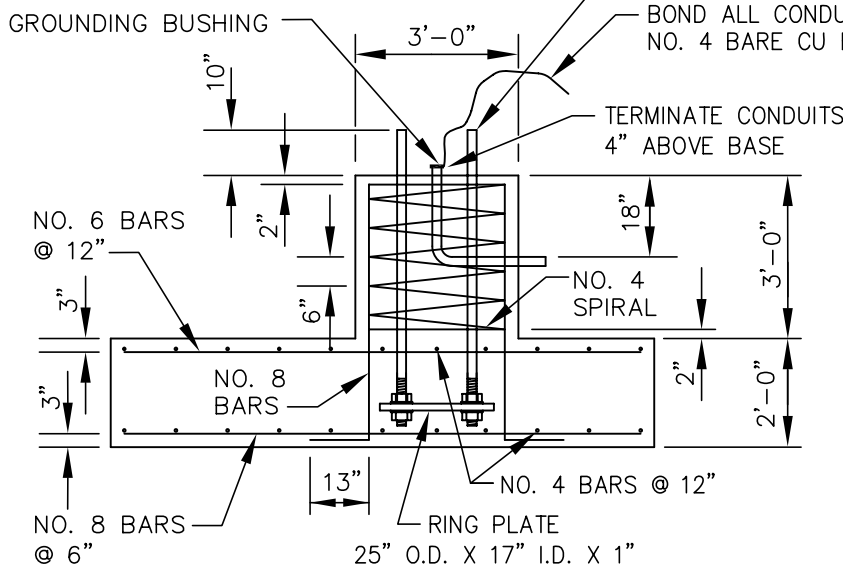

SPREAD FOOTING DETAIL

NOTES:

1. INSTALL THE SPREAD FOOTINGS SO THE MAST ARM IS PARALLEL WITH THE 10'-0" DIMENSION.
2. CAST ALL FOOTINGS IN PLACE.
3. ANCHOR BOLTS SHALL CONFORM TO ASTM F1554, WITH GRADE AS SPECIFIED BY THE MANUFACTURER.
4. REINFORCING STEEL SHALL CONFORM TO ASTM A615, GRADE 60 FOR DEFORMED BARS OF BILLET STEEL.
5. EACH SPIRAL REBAR UNIT WITHIN EACH FOOTING SHALL HAVE 1-1/2 TURNS OF THE REBAR AT EACH END OF THE UNIT.
6. GALVANIZING OF ANCHOR BOLTS, NUTS, AND WASHERS SHALL CONFORM TO ASTM A153.
7. STEEL ANCHOR PLATES SHALL CONFORM TO ASTM A36.
8. FOUNDATION BASE SHALL HAVE A BROOMED FINISH.
9. REFERENCE TOP BACK OF CURB IN ESTABLISHING FOUNDATION TOP ELEVATION. SET TOP OF FOUNDATION FLUSH WITH SIDEWALK/PAVING FINISH GRADE OR 2"-4" ABOVE FINISH GROUND ELEVATION.

MUNICIPALITY



OF ANCHORAGE

SCALE:
NTS

APPROVED:

REVISED:
5/08

**POURED CONCRETE
SPREAD FOOTING SIGNAL
POLE FOUNDATION**

SECTION #
80.04

DETAIL #
80-11

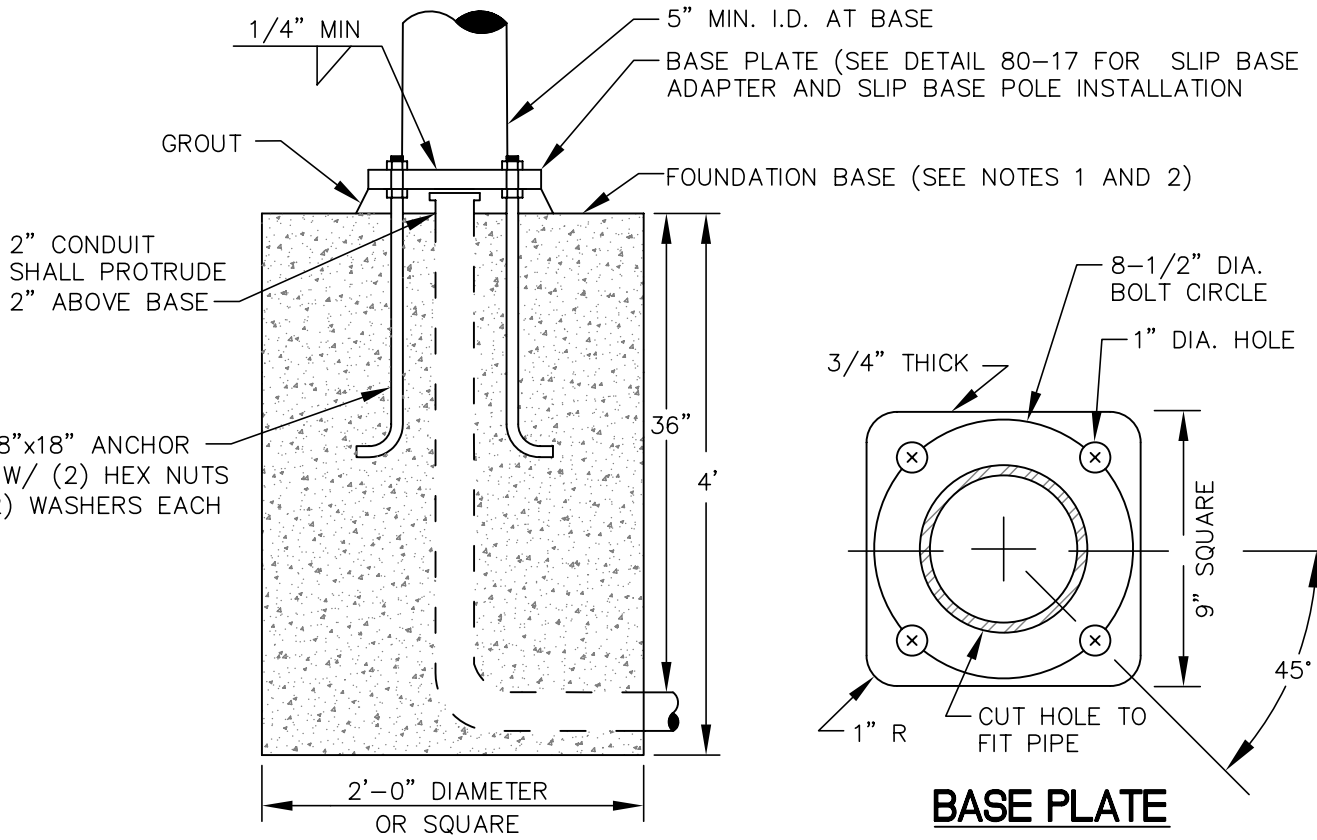

**10' PEDESTAL SIGNAL
POLE FOUNDATION**

**BASE PLATE
PLAN VIEW**
(BOTH FOUNDATION TYPES)

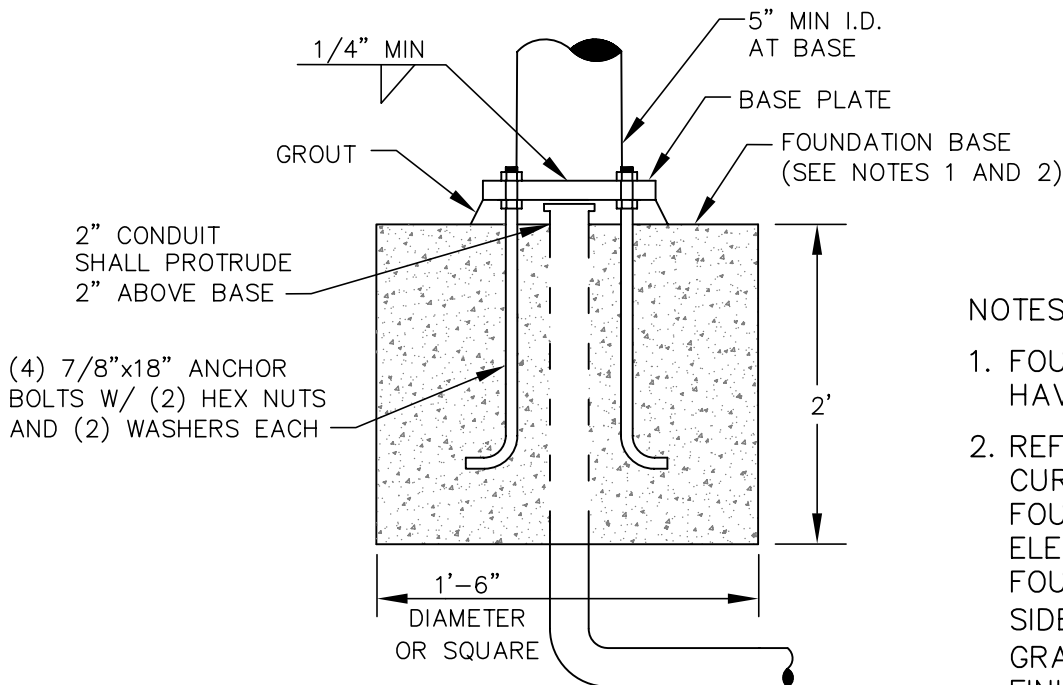

5' PEDESTRIAN PUSH BUTTON FOUNDATION

NOTES:

1. FOUNDATION BASE SHALL HAVE A BROOMED FINISH.
2. REFERENCE TOP BACK OF CURB IN ESTABLISHING FOUNDATION TOP ELEVATION. SET TOP OF FOUNDATION FLUSH WITH SIDEWALK/PAVING FINISH GRADE OR 2"-4" ABOVE FINISH GROUND ELEVATION.

MUNICIPALITY



OF ANCHORAGE

SCALE:
NTS

APPROVED:

REVISED:
6/08

**CONCRETE FOUNDATIONS FOR
SIGNAL PEDESTAL POLE AND
PEDESTRIAN PUSH BUTTON POLE**

SECTION #
80.04,
80.05

DETAIL #
80-12

TRAFFIC

POSITION ONE CORNER OF PILE SLIP BASE CAP PERPENDICULAR TO TRAFFIC LANE

PROVIDE 1-1/2" THICK PLATE FOR LUMINAIRE POLES 40' AND LESS IN LENGTH. PROVIDE 2" THICK PLATES FOR LUMINAIRE POLES FROM 40 FEET TO 50 FEET IN LENGTH.

POSITION THE FLAT SIDE PARALLEL TO TRAFFIC LANE

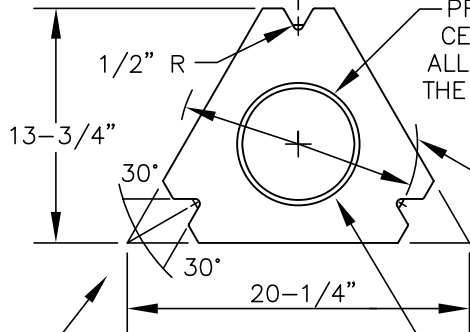

PROVIDE 8-3/4" DIA. HOLE IN CENTER OF STEEL PILE CAP TO ALLOW STEEL PILE TO EXTEND TO THE MID ELEVATION OF THE STEEL PLATE.

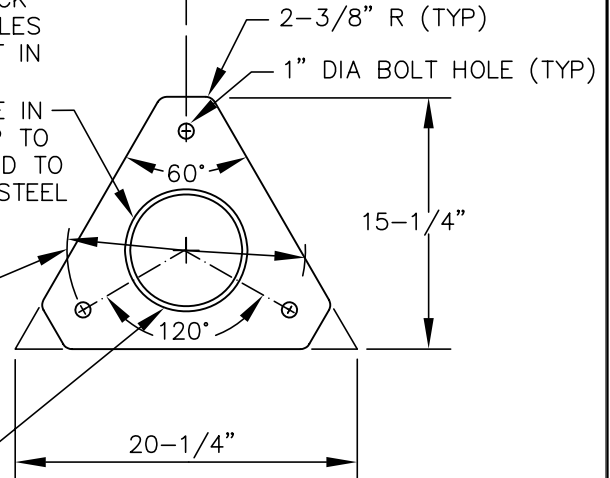

STEEL SLIP BASE PILE CAP TO MATCH LUMINAIRE BASE.

WELD IN CONFORMANCE WITH AWS D1.1 BY WELDERS CERTIFIED FOR AWS 6G QUALIFICATION TEST.

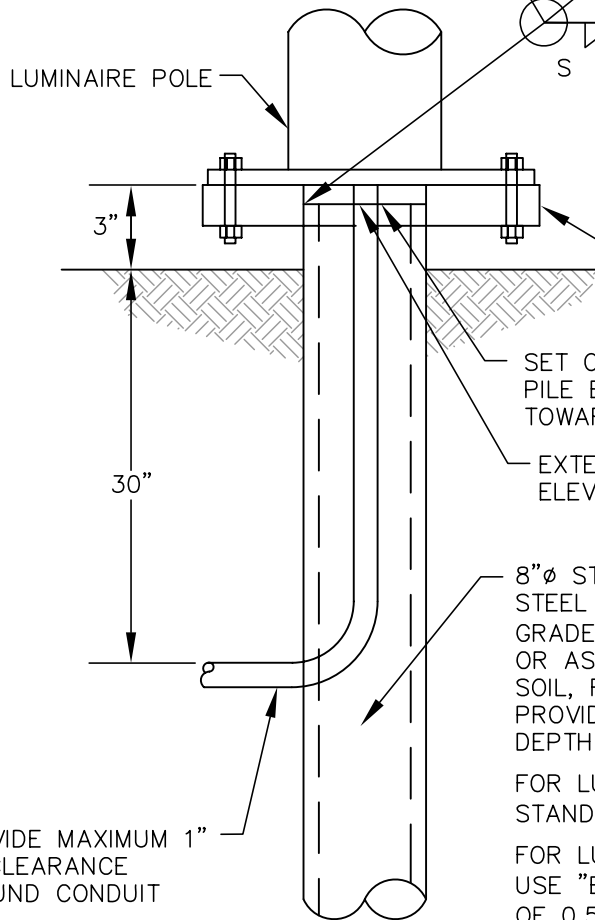

USE 3/8" WELD FOR 1-1/2" PLATE & 1/2" WELD FOR 2" PLATE

SEE STANDARD DETAIL 80-21 FOR PILE/POLE ASSEMBLY

SET CONDUIT FLUSH WITH TOP OF PILE BASE PLATE AND SLOPE TOWARDS LIGHT POLE HAND HOLE

EXTEND THE PIPE PILE TO THE MID ELEVATION OF THE STEEL PIPE CAP

8"Ø STEEL PIPE PILE:
STEEL PIPE USED FOR PILING SHALL CONFORM TO ASTM A53, GRADE B. CONTRACTOR SHALL PROVIDE A 15' MINIMUM EMBEDMENT OR AS INDICATED IN DRAWINGS FOR PILING INSTALLED IN GRANULAR SOIL, FREE OF ORGANICS AND DEBRIS. FOR OTHER CONDITIONS, PROVIDE A FOUNDATION INVESTIGATION TO DETERMINE EMBEDMENT DEPTH AND OTHER PILE DESIGN CRITERIA.

FOR LUMINAIRE POLES 40 FEET OR LESS IN LENGTH, USE STANDARD STEEL PIPE PILES WITH A WALL THICKNESS OF 0.322".

FOR LUMINAIRE POLES BETWEEN 40 FEET AND 50 FEET IN LENGTH, USE "EXTRA STRONG" STEEL PIPE PILES WITH A WALL THICKNESS OF 0.500".

PROVIDE MAXIMUM 1" OF CLEARANCE AROUND CONDUIT

REVISION: 12/09 ADDED FIXED BASE SPECIFICATIONS

MUNICIPALITY



OF ANCHORAGE

SCALE:
NTS

APPROVED:

REVISED:
12/09

DRIVEN STEEL PILE LIGHT POLE FOUNDATION

SECTION #
80.04

DETAIL #
80-13

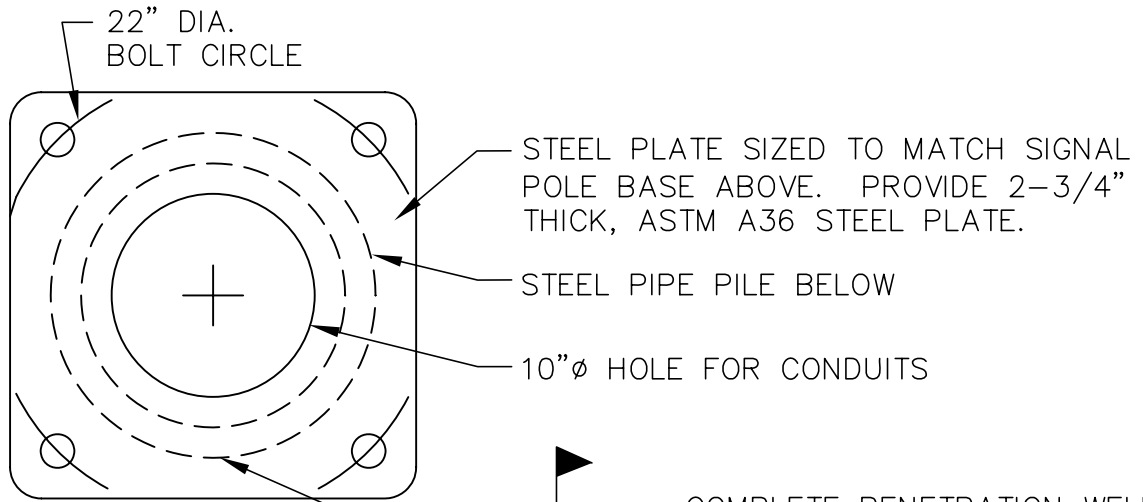

PLAN VIEW

COMPLETE PENETRATION WELD IN CONFORMANCE WITH AWS D1.1 BY WELDERS CERTIFIED FOR AWS 6G QUALIFICATION TEST

SIGNAL MAST ARM POLE

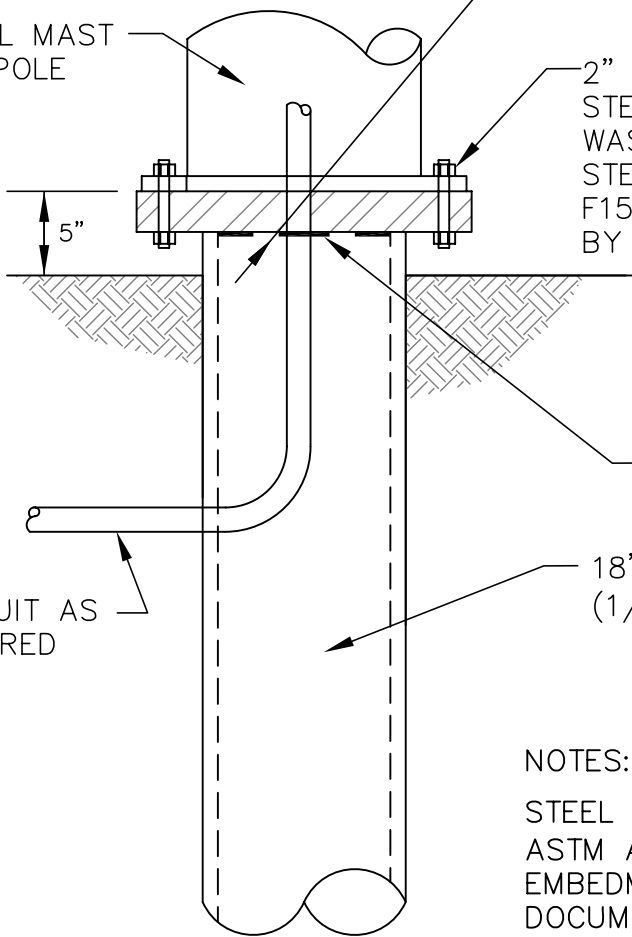

SECTION

2" x 12" GALVANIZED ALL THREAD STEEL RODS, WITH A NUT AND WASHER ON EACH END OF THE BOLT. STEEL SHALL CONFORM TO ASTM F1554, WITH GRADE AS DETERMINED BY THE POLE MANUFACTURER.

SEE PLAN DETAIL ABOVE FOR STEEL PLATE PILE CAP DETAIL

18"Ø STEEL PIPE PILE (1/2" WALL THICKNESS)

CONDUIT AS REQUIRED

NOTES:

STEEL PIPE USED FOR PILING SHALL CONFORM TO ASTM A53, GRADE B. PROVIDE A 25' MINIMUM EMBEDMENT OR AS INDICATED IN CONTRACT DOCUMENTS FOR PILING INSTALLED IN GRANULAR SOIL, FREE OF ORGANICS AND DEBRIS. FOR OTHER CONDITIONS, PROVIDE A FOUNDATION INVESTIGATION TO DETERMINE EMBEDMENT DEPTH AND OTHER PILE DESIGN CRITERIA.

MUNICIPALITY



OF ANCHORAGE

SCALE:
NTS

APPROVED:

REVISED:
10/07

**DRIVEN STEEL PILE
SIGNAL POLE FOUNDATION**

SECTION #
80.04

DETAIL #
80-14

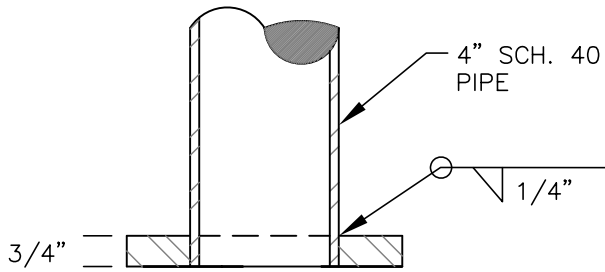

**BASE PLATE
DETAILS**

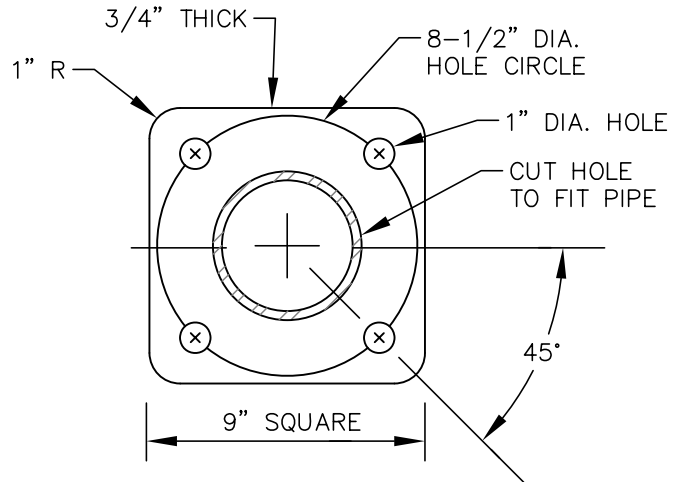

PLAN VIEW

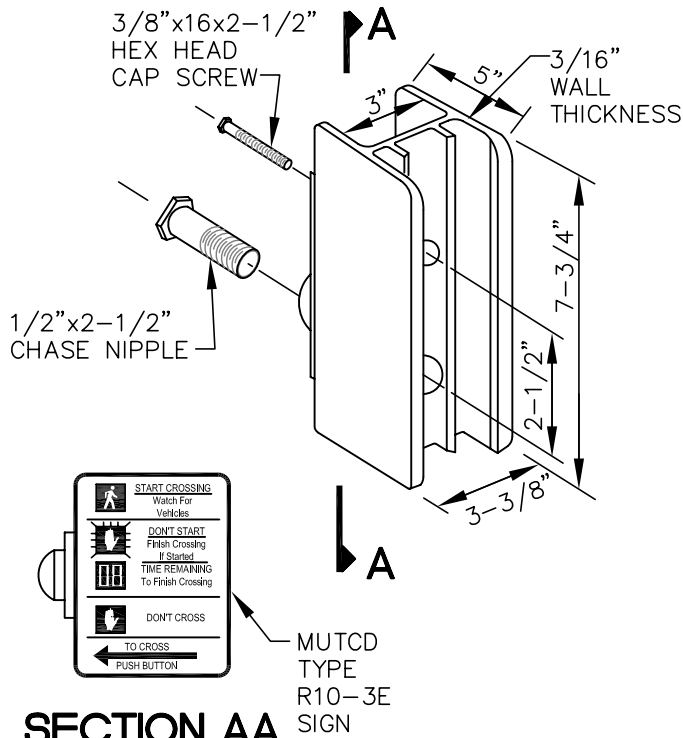

SECTION AA

"H" STYLE HOUSING

AMERICAN POLE STRUCTURES, INC.
MODEL H-1

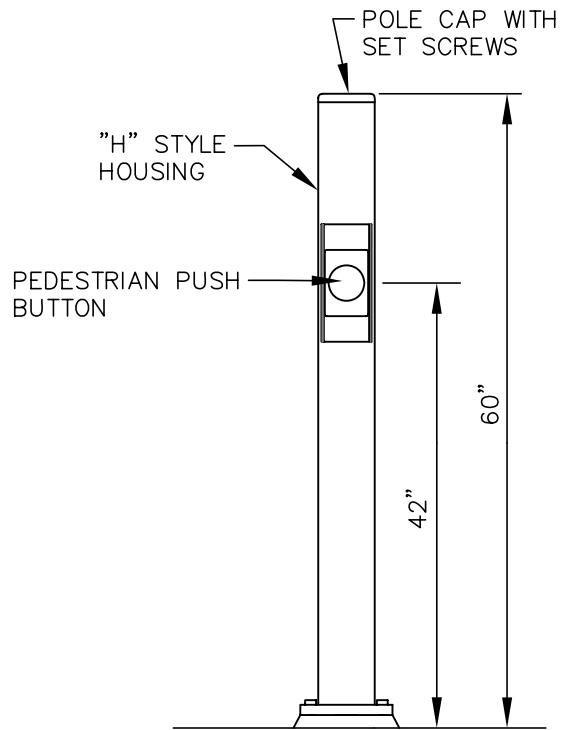

POLE DETAIL

NOTES:

1. SEE DETAIL 80-12 FOR FOUNDATION.
2. SEE DETAIL 80-28 FOR PEDESTRIAN PUSH BUTTON.

MUNICIPALITY



OF ANCHORAGE

SCALE:
NTS

APPROVED:

REVISED:
10/07

**PEDESTRIAN PUSH BUTTON
POLE**

SECTION #
80.05

DETAIL #
80-15

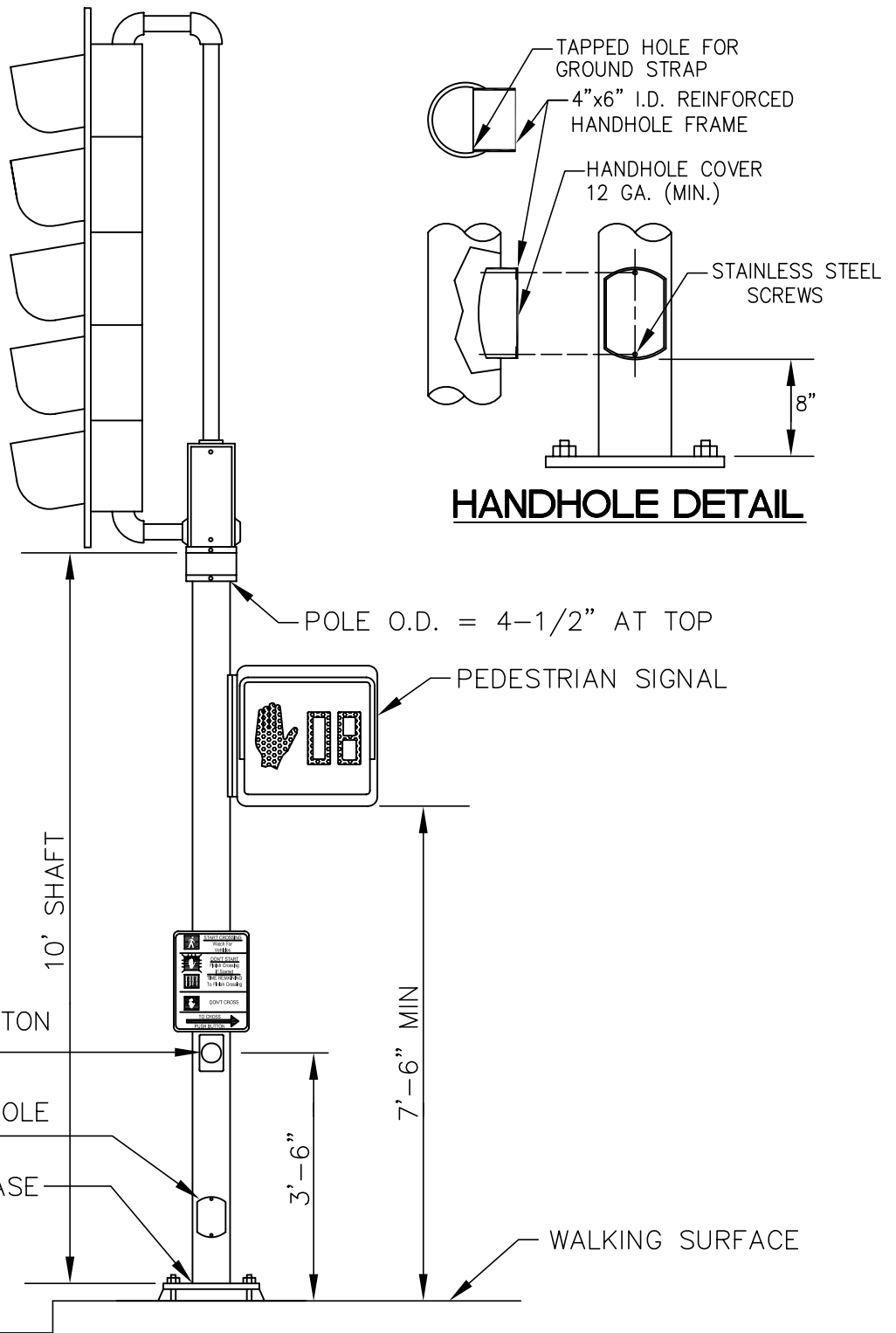

NOTES:

1. SEE DETAIL 80-17 FOR SLIP BASE AND ADAPTER.
2. SEE DETAIL 80-12 FOR FLANGE TYPE BASE PLATE.
3. SEE DETAIL 80-12 FOR CONCRETE FOUNDATION.

MUNICIPALITY



OF ANCHORAGE

SCALE:
NTS

APPROVED:

REVISED:
5/08

SIGNAL PEDESTAL POLE

SECTION #
80.05

DETAIL #
80-16

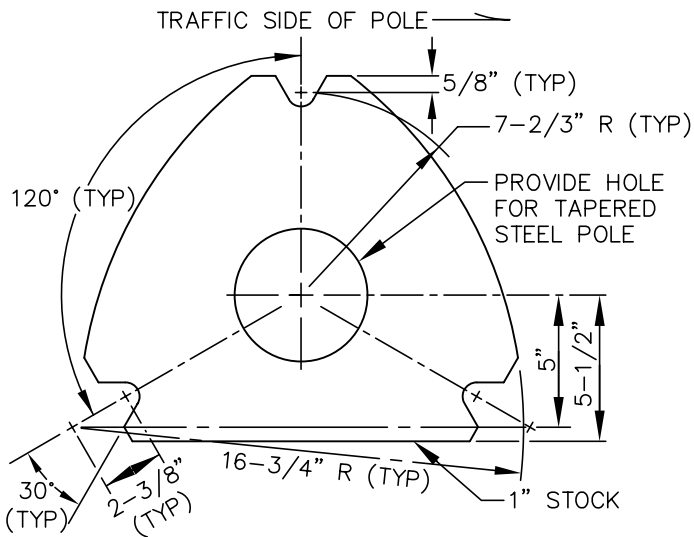

TOP SLIP BASE PLATE

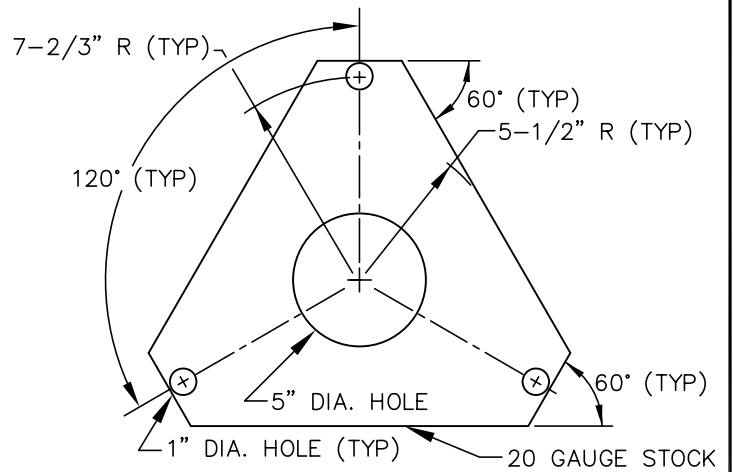

KEEPER PLATE

(SEE DETAIL 80-12 FOR FOUNDATION)

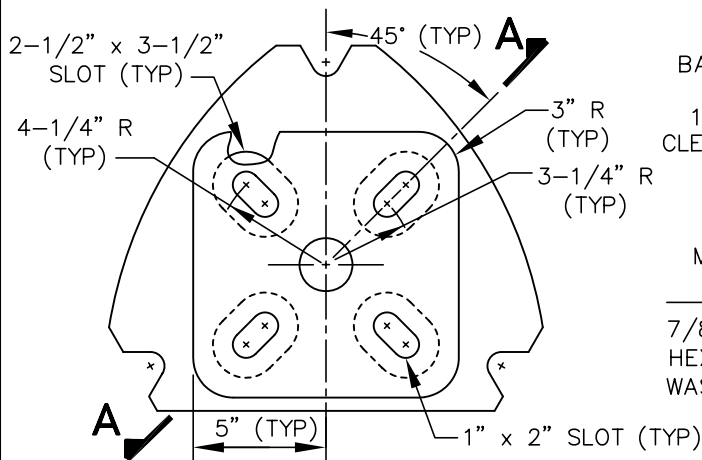

BOTTOM SLIP BASE PLATE

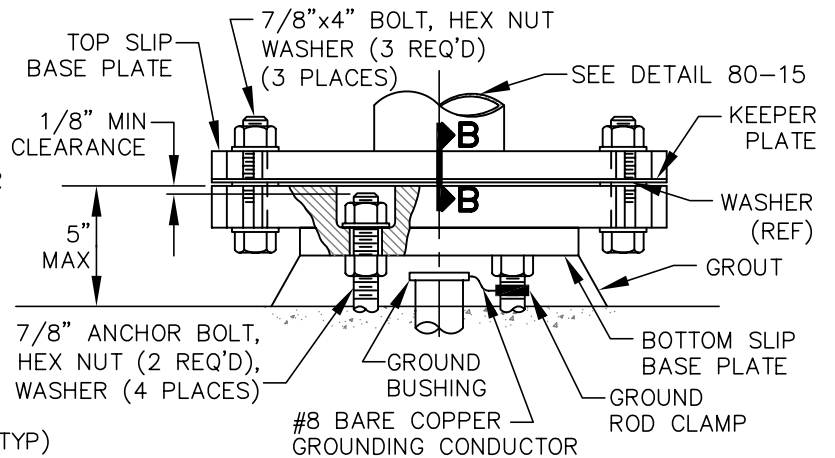

SLIP BASE INSTALLATION

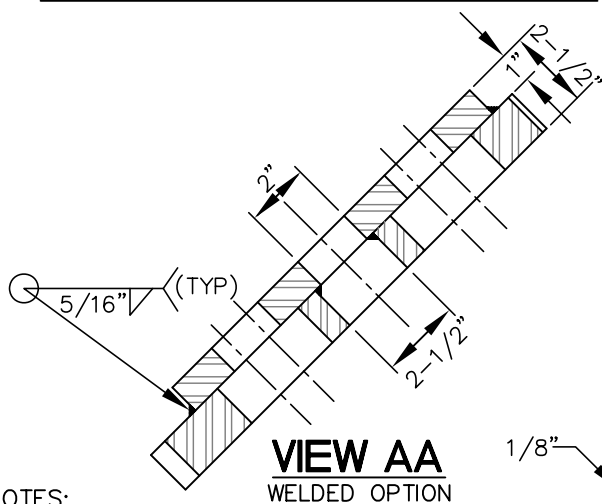

**VIEW AA
WELDED OPTION**

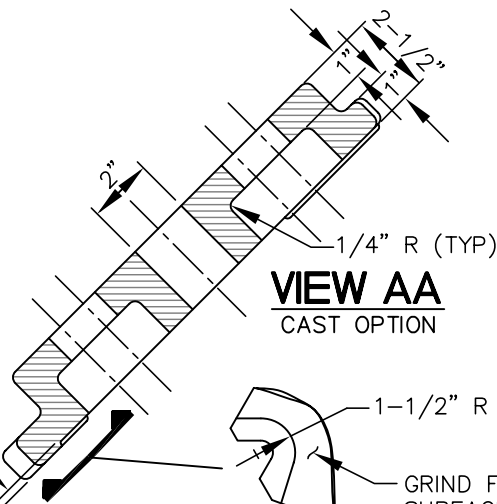

**VIEW AA
CAST OPTION**

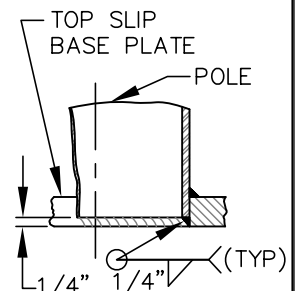

VIEW BB

NOTES:

1. TORQUE 7/8" H.S. SLIP BASE PLATE BOLTS TO 800 INCH-LBS.
2. PLATES SHALL CONFORM TO ASTM A36.
3. CAST OPTION SHALL CONFORM TO ASTM A486, CLASS 90.
4. KEEPER PLATE SHALL CONFORM TO ASTM A446, GRADE A.
5. ALL WELDS SHALL CONFORM TO AMERICAN WELDING SOCIETY SPECIFICATIONS.
6. SEE STANDARD DETAIL 80-12 FOR BOLT HOLE CIRCLE PATTERN.

MUNICIPALITY



OF ANCHORAGE

SCALE:
NTS

APPROVED:

REVISED:
7/08

**PEDESTAL SIGNAL POLE
SLIP-BASE AND ADAPTER
DETAIL**

SECTION #
80.05

DETAIL #
80-17

SEE DETAIL C
STANDARD DETAIL 80-20

SEE STANDARD DETAIL 80-20
FOR ARM DETAILS

NOTES:

1. EXCAVATE HOLE TO A MINIMUM DEPTH OF 7'-0" BELOW FINISHED GRADE.
2. PLACE ONE FOOT (1') OF COARSE ROCK BEDDING, INSTALLED UNLESS OTHERWISE SPECIFIED.
3. THIS POLE FOR USE WITH ARMS OF 8'-0" MAXIMUM LENGTH.
4. INSTALL JUNCTION BOX BEHIND LIGHT POLE AWAY FROM TRAFFIC. OTHER LOCATIONS AS DIRECTED BY THE ENGINEER.
5. PROVIDE NON-FROST SUSCEPTIBLE COMPACTED MATERIAL AROUND POLE AS REQUIRED.

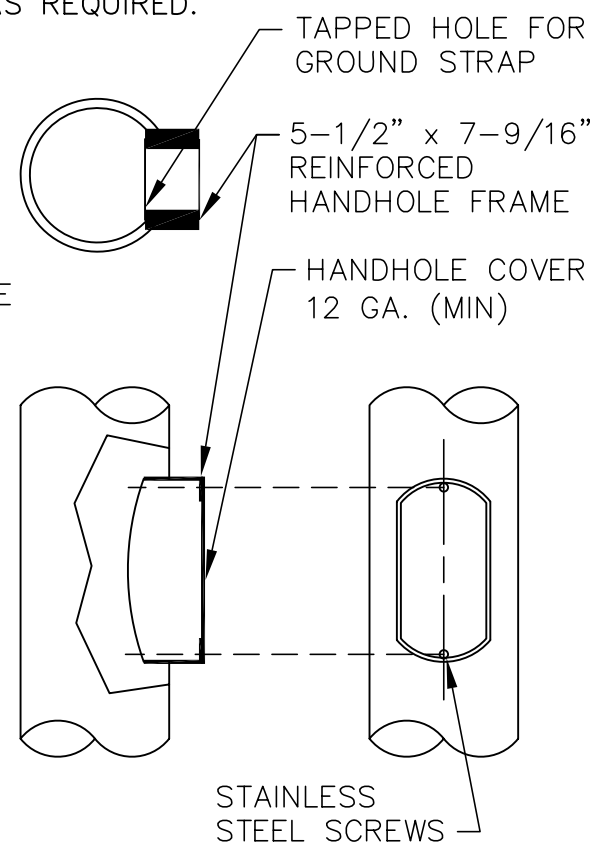
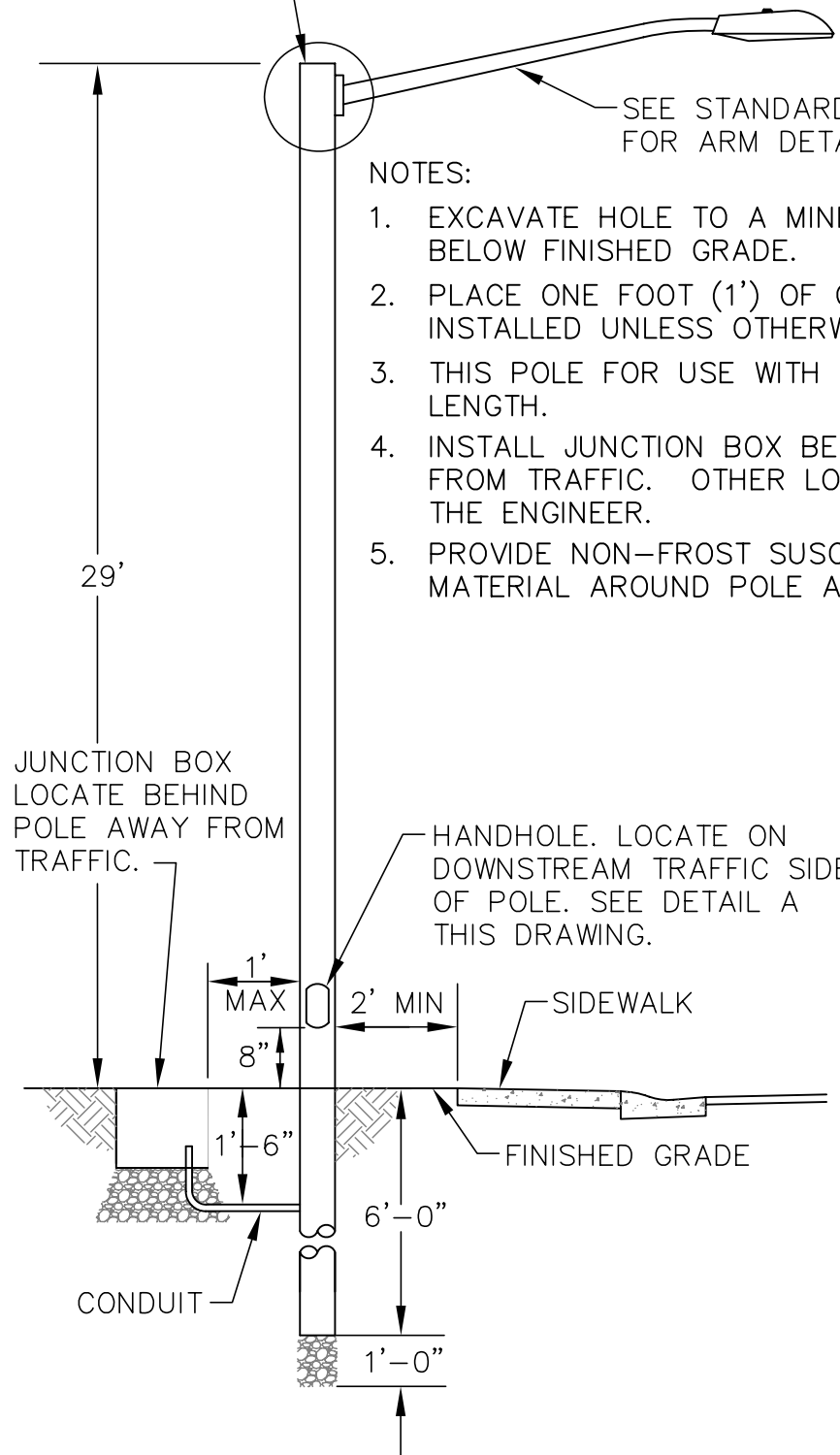

DETAIL A

MUNICIPALITY
OF ANCHORAGE

SCALE:
NTS

APPROVED:

REVISED:
10/08

**DIRECT IMBEDDED
LUMINAIRE POLE**

SECTION #
80.08

DETAIL #
80-18

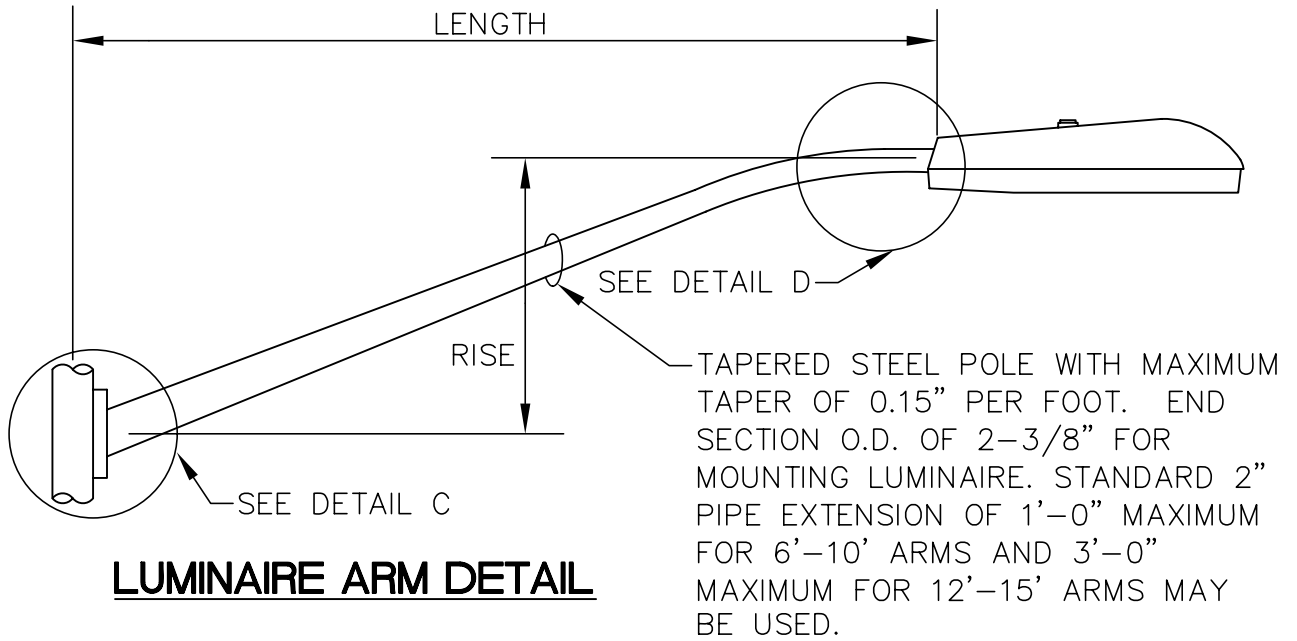

LUMINAIRE ARM DETAIL

LENGTH	RISE
6'	1.5'
8'	2.2'
10'	2.5'
12'	3.6'
15'	4.3'
22'	6.0'

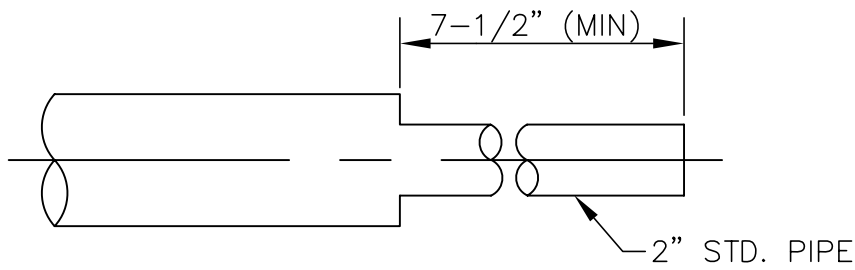

DETAIL D

3 EA. 3/4"-10 TAP. POLE PLATE FOR 3/4" BOLTS. BOLTS SHALL CONFORM TO ASTM A325 AND GALVANIZED IN ACCORDANCE WITH ASTM A135.

2" CHASED OUTLET FOR ELECTRICAL CONDUCTORS

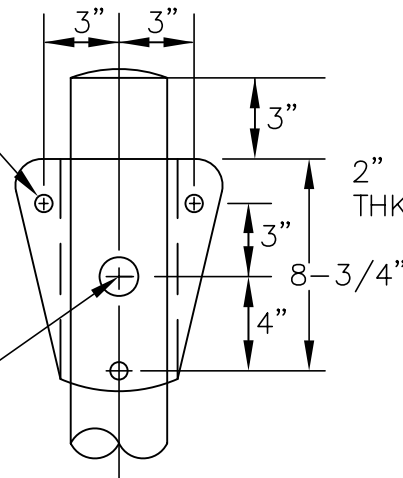

DETAIL C

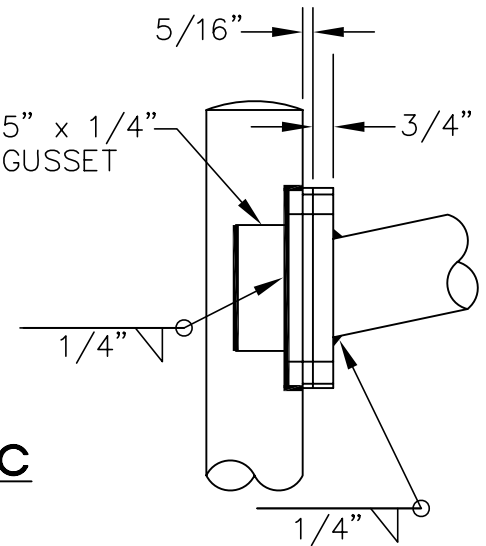

MUNICIPALITY



OF ANCHORAGE

SCALE:
NTS

APPROVED:

REVISED:
7/08

LUMINAIRE ARM DETAIL

SECTION #
80.05

DETAIL #
80-20

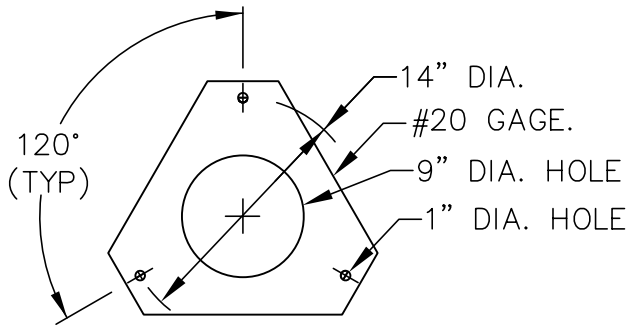

KEEPER PLATE

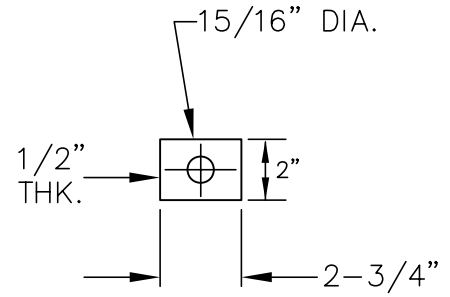
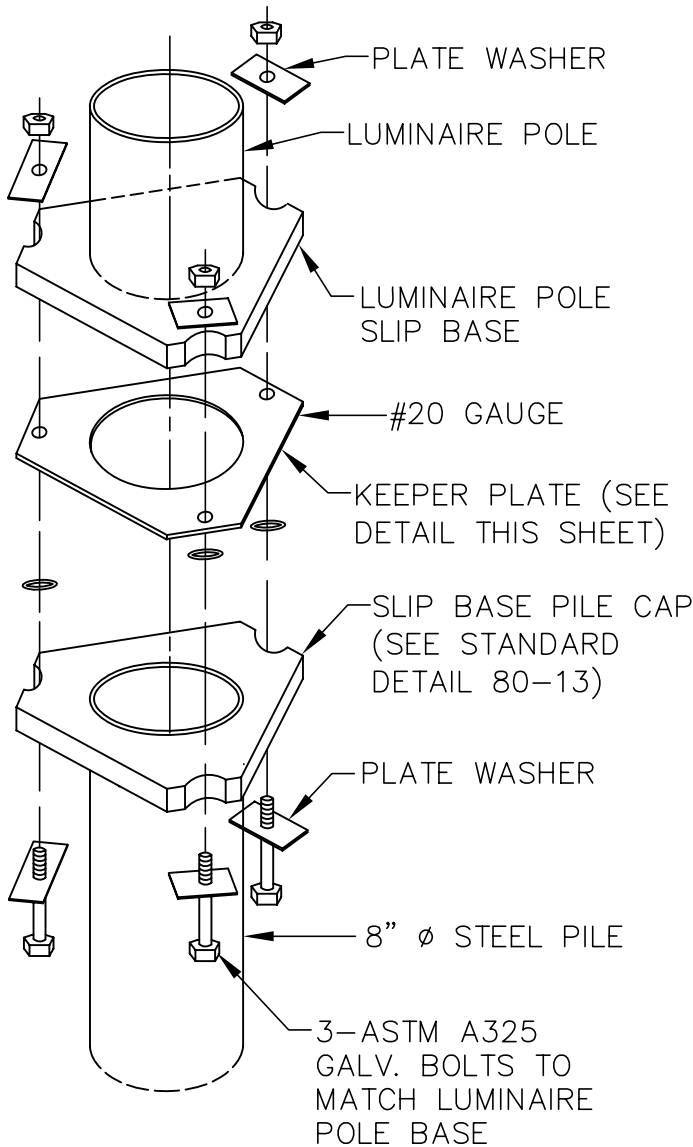
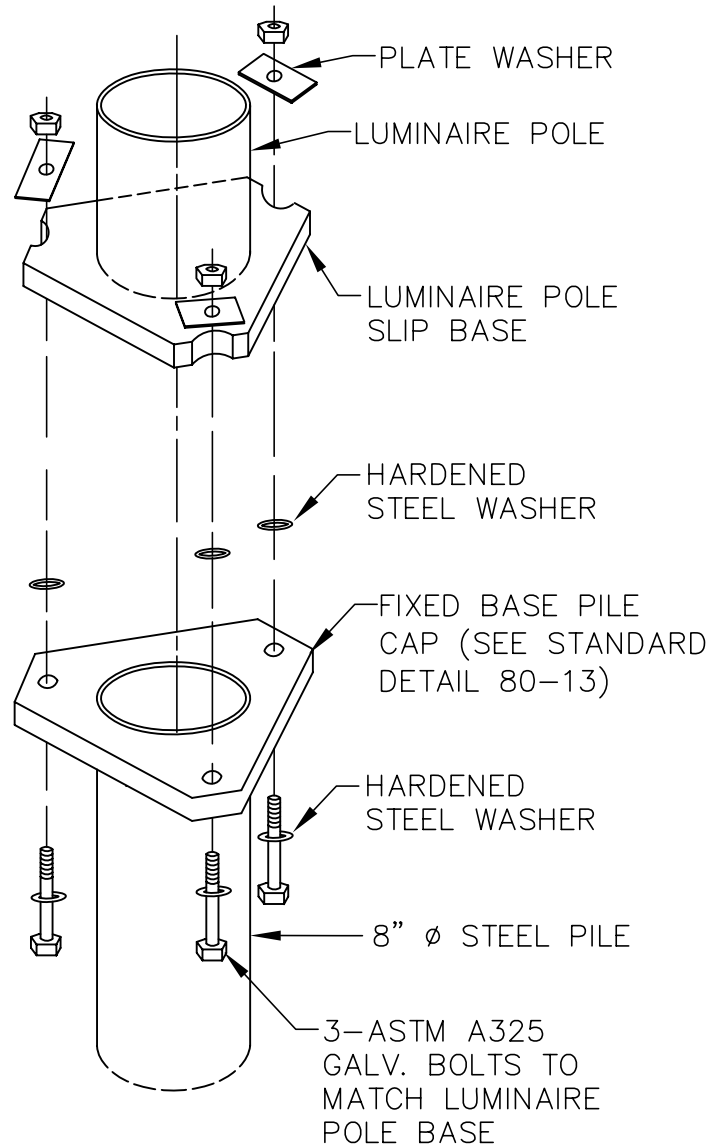

PLATE WASHER



SLIP BASE ASSEMBLY



FIXED BASE ASSEMBLY

REVISION: 12/09 ADDED FIXED BASE SPECIFICATIONS

MUNICIPALITY



OF ANCHORAGE

SCALE:
NTS

APPROVED:

REVISED:
12/09

**DRIVEN STEEL PIPE
POLE ASSEMBLIES**

SECTION #
80.04

DETAIL #
80-21

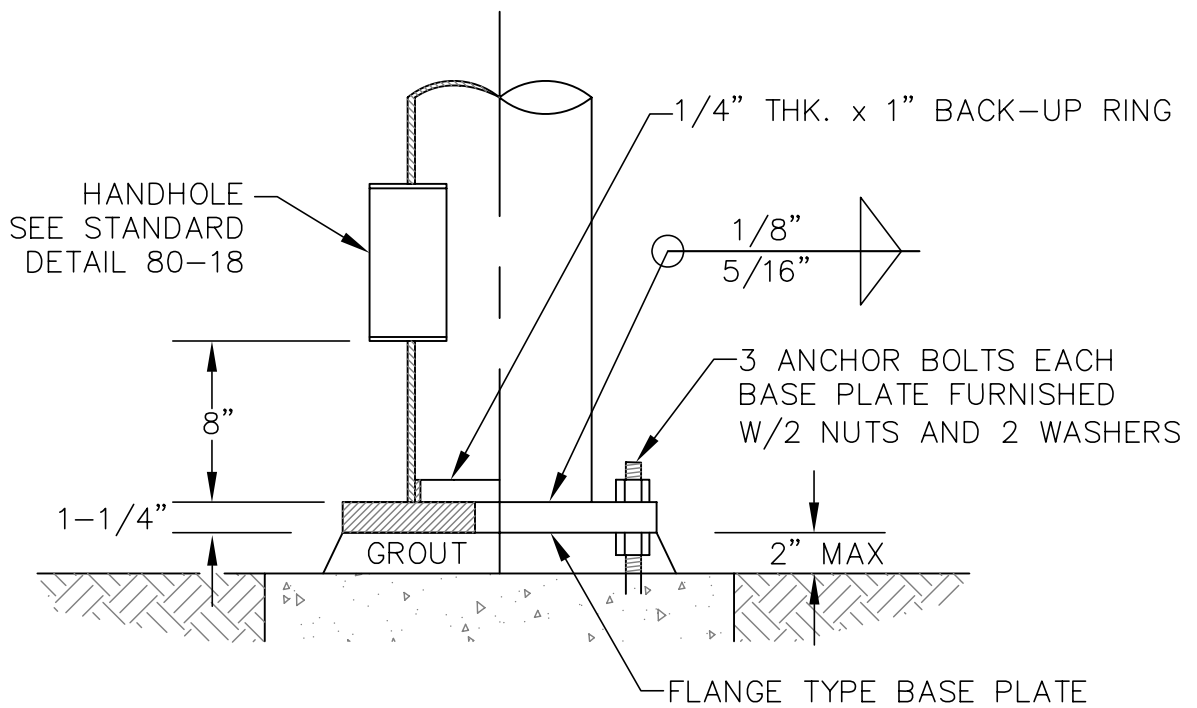

MUNICIPALITY



OF ANCHORAGE

SCALE:
NTS

APPROVED:

REVISED:
7/08

FLANGE-MOUNTED DETAIL FOR CONCRETE LUMINAIRE BASE

SECTION #
80.05

DETAIL #
80-22

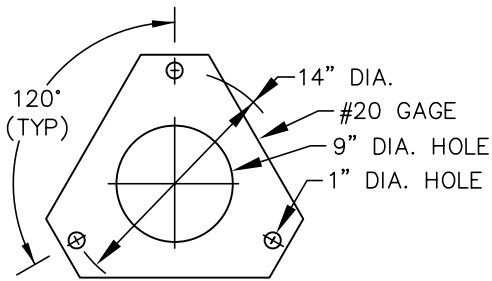

KEEPER PLATE

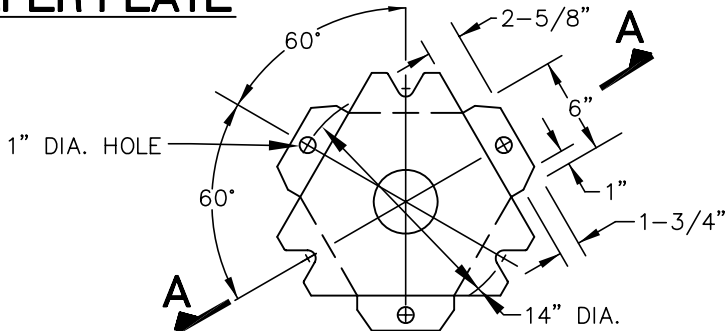

BOTTOM SLIP BASE PLATE

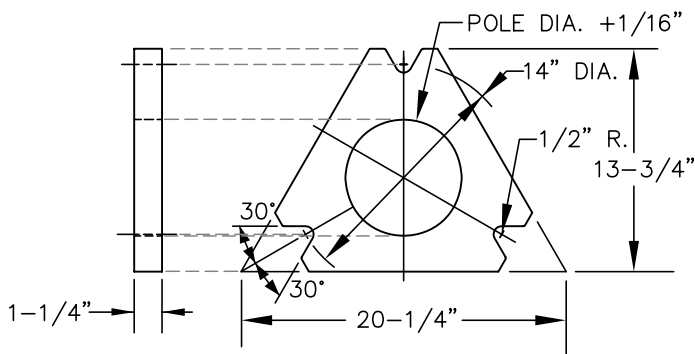

TOP SLIP BASE PLATE

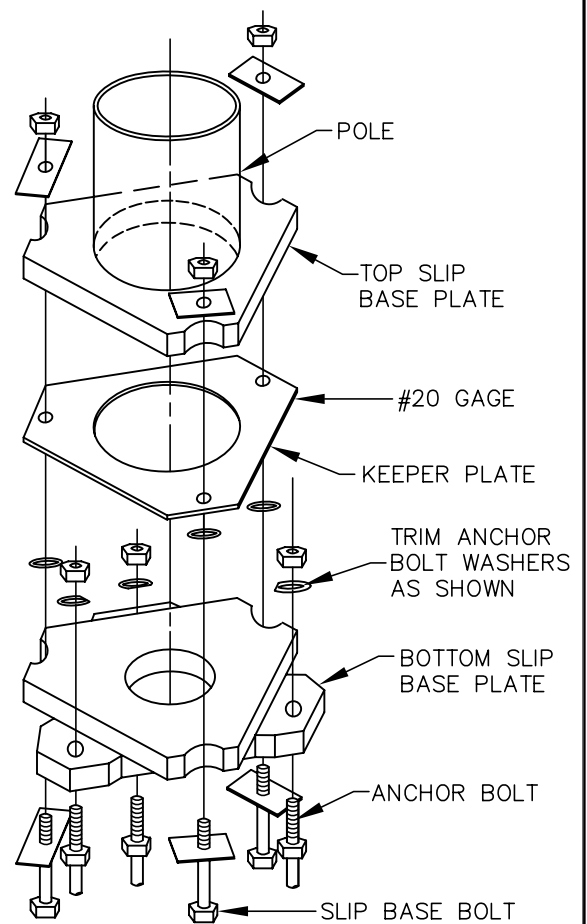

SLIP BASE ASSEMBLY

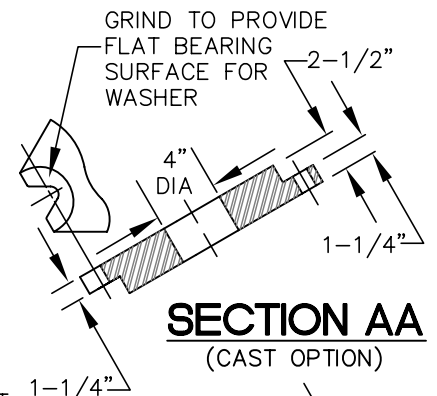

SECTION AA
(CAST OPTION)

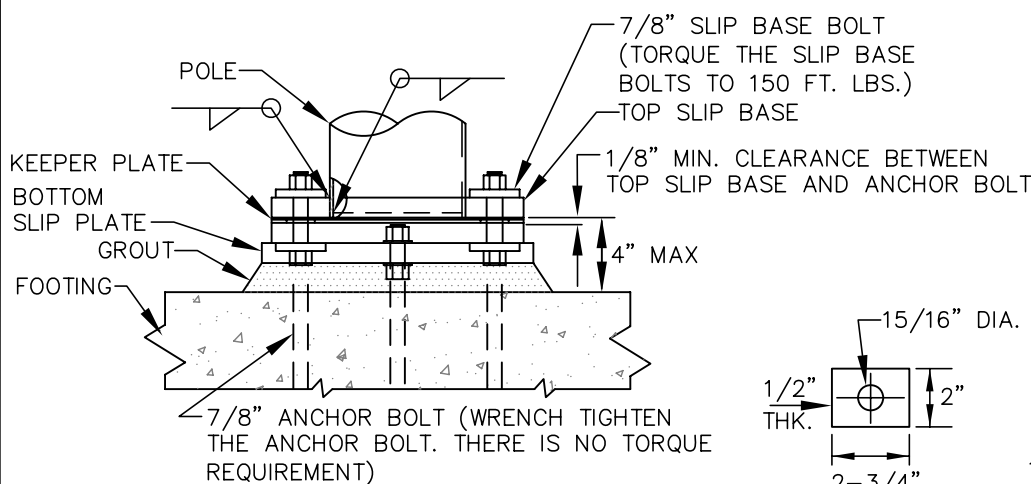

SLIP BASE INSTALLATION

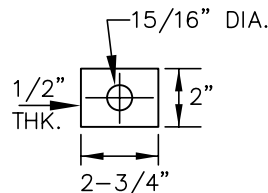
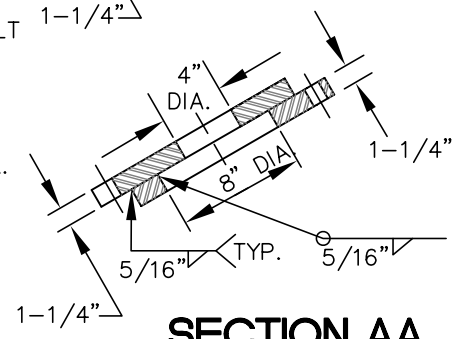

PLATE WASHER



SECTION AA
(WELDED OPTION)

MUNICIPALITY



OF ANCHORAGE

SCALE:
NTS

APPROVED:

REVISED:
7/08

**CONCRETE LUMINAIRE BASE
SLIP-BASE DETAIL**

SECTION #
80.05

DETAIL #
80-23

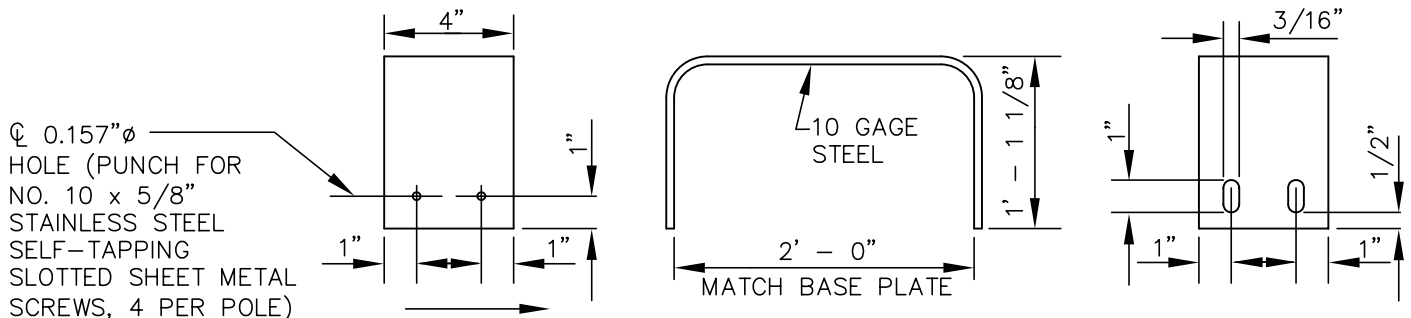
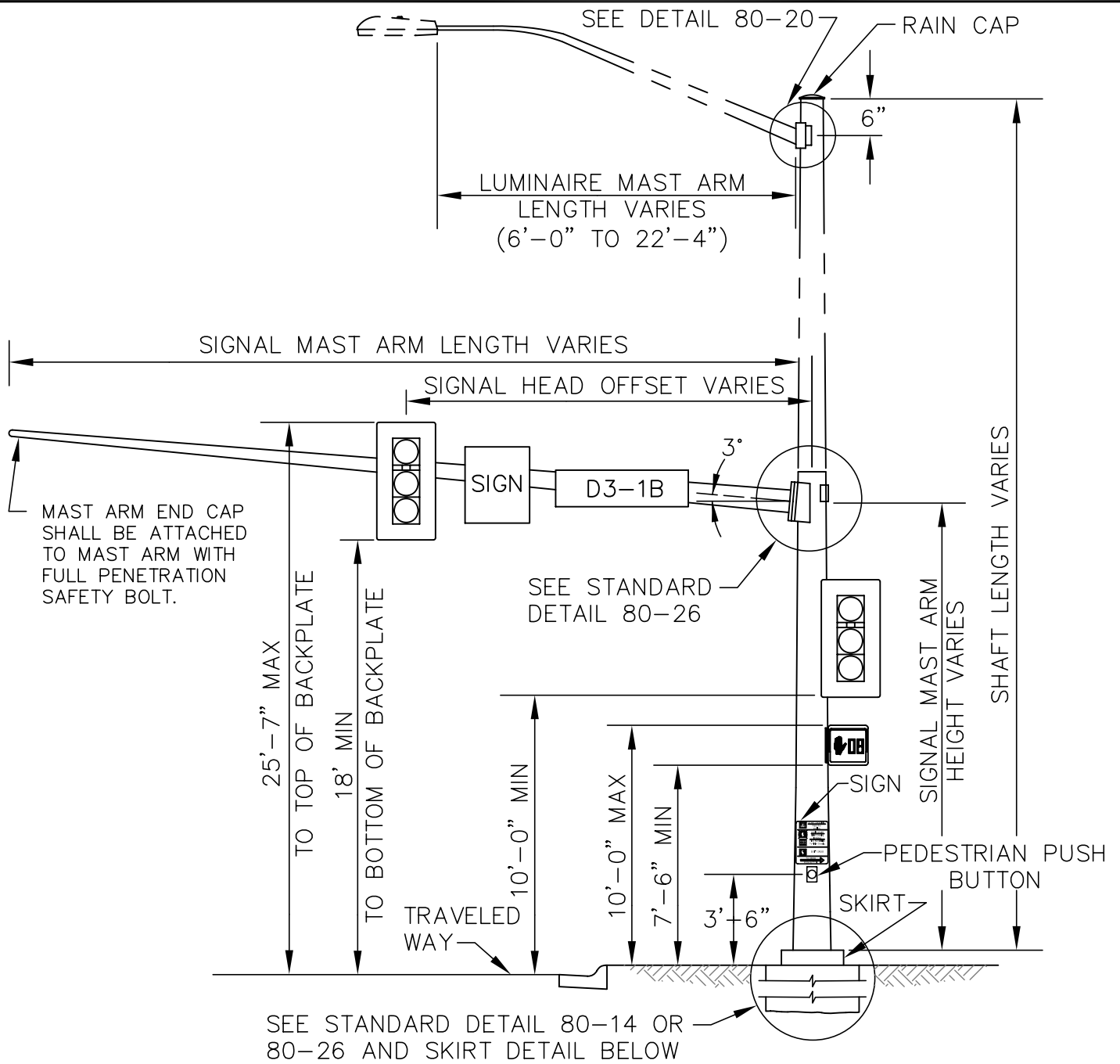

SKIRT DETAILS
(TWO REQUIRED PER POLE)

MUNICIPALITY

OF ANCHORAGE

SCALE:
NTS

APPROVED:

REVISED:
8/08

**SIGNAL MAST ARM POLE
AND COMBINATION
SIGNAL/LUMINAIRE POLE**

SECTION #
80.05

DETAIL #
80-24

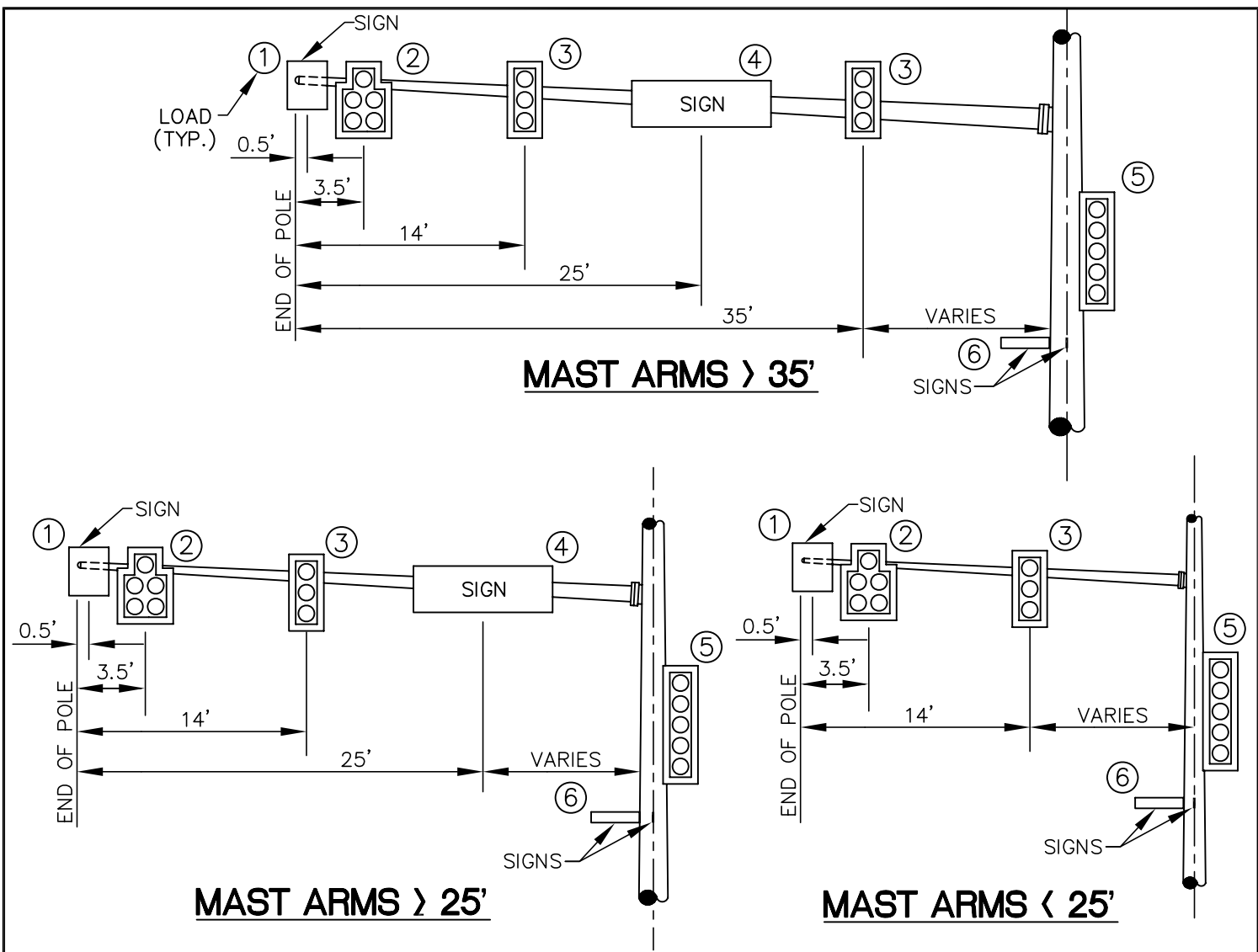

MINIMUM DESIGN LOADING TABLE

LOAD #	DESCRIPTION	WEIGHT (LBS)	PROJECTED AREA (FT ²)
1	SIGN	65	7.5
2	SIGNAL	80	14.7
3	SIGNAL	60	8.7
4	SIGN	80	26
5	SIGNAL	125	7.6
6	STREET NAME SIGN		2.0

NOTES:

- LOAD #5 SHALL BE SHAFT MOUNTED 14 FEET FROM THE BASE OF THE POLE.
- LOAD #6 IS SHAFT MOUNTED 12 FEET FROM THE BASE OF THE POLE.

 <p>MUNICIPALITY OF ANCHORAGE</p>	<p>SCALE: NTS</p> <p>APPROVED:</p> <p>REVISED: 10/08</p>	<p>SIGNAL MAST ARM / POLE DESIGN LOADING</p>	<p>SECTION # 80.05</p> <p>DETAIL # 80-25</p>
--	--	---	--

MAST ARM DATA TABLE

MAST ARM LENGTH	BOLT CIRCLE
≤ 15'	12-1/2"
16' to 26'	13-1/2"
27' to 39'	15"
40' to 45'	15-1/2"
46' to 55'	18-1/2"
55' to 65'	19"

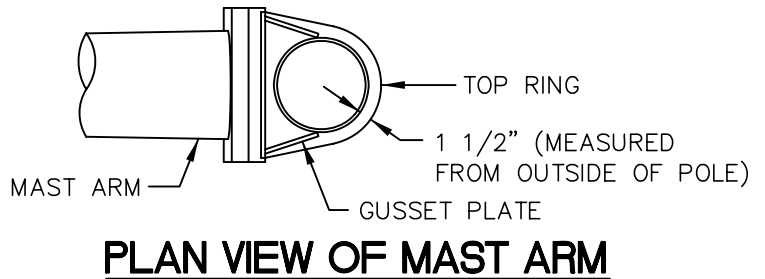

PLAN VIEW OF MAST ARM

INSTALL 1-1/2" ASTM A325 BOLTS ON A SQUARE PATTERN

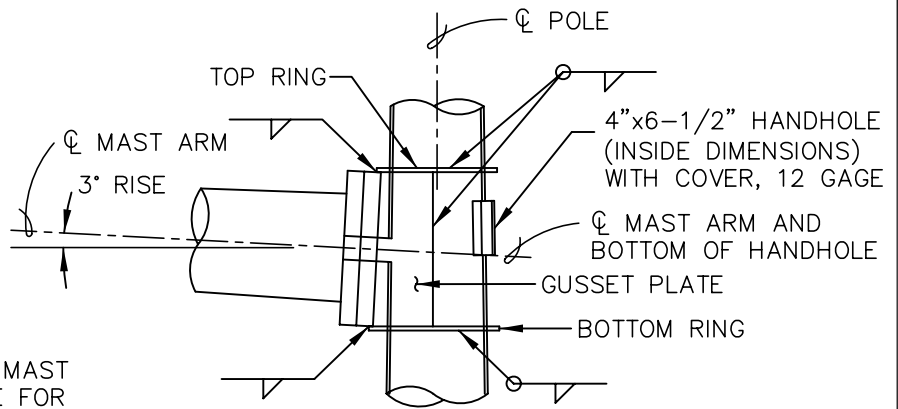
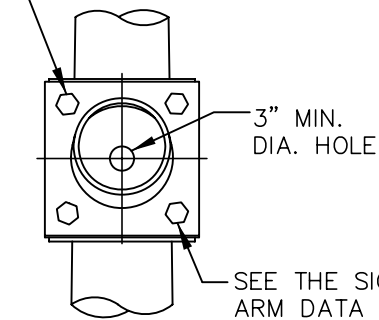

MAST ARM CONNECTION DETAILS

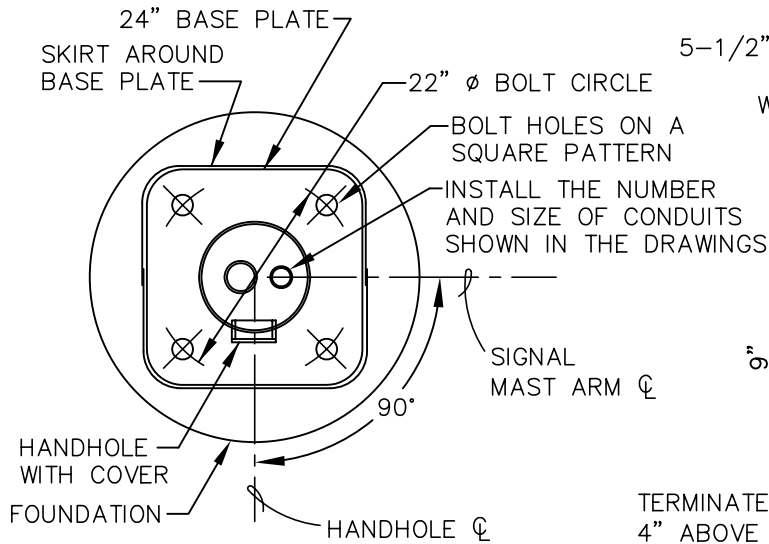

PLAN VIEW

(SHOWN WITHOUT ANCHOR BOLTS AND NUTS FOR CLARITY)

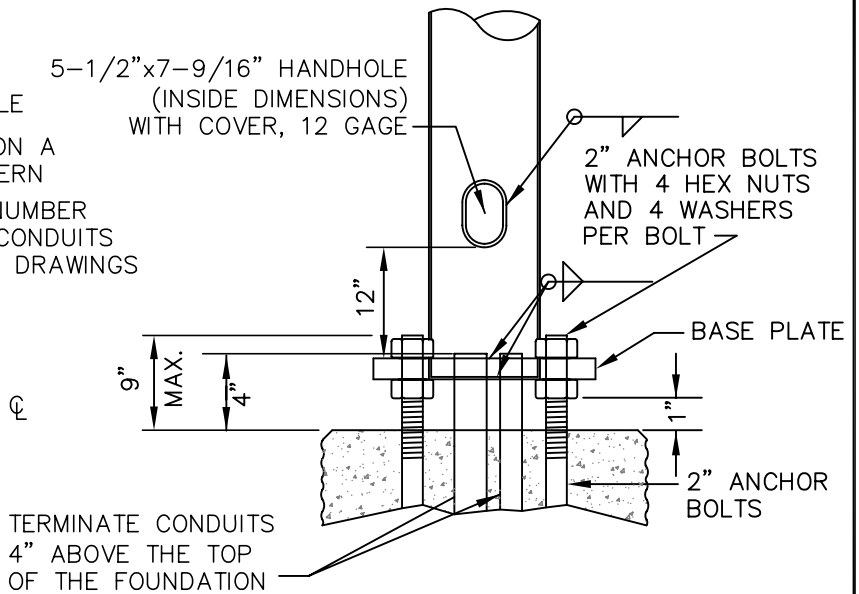

POLE BASE DETAIL

(SEE DETAIL 80-14 FOR DRIVEN STEEL PILE SIGNAL POLE FOUNDATION)

NOTES:

1. SEE STANDARD DETAIL 80-24 FOR SIGNAL MAST ARM POLE AND SKIRT DETAILS.
2. SEE STANDARD DETAILS 80-10, 80-11 & 80-14 FOR FOUNDATION DETAILS.

MUNICIPALITY



OF ANCHORAGE

SCALE:
NTS

APPROVED:

REVISED:
6/08

**DETAILS-SIGNAL MAST ARM
POLE AND
SIGNAL / LUMINAIRE POLE**

SECTION #
80.05,06

DETAIL #
80-26

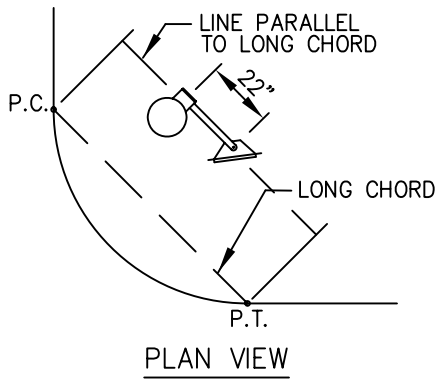

PLAN VIEW

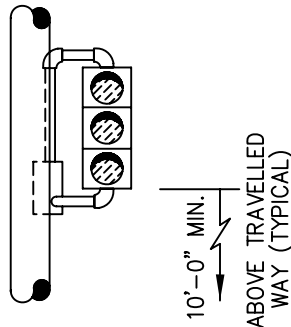

USE A ONE WAY, L.O.D. FRAME FOR INSTALLING ONE FACE

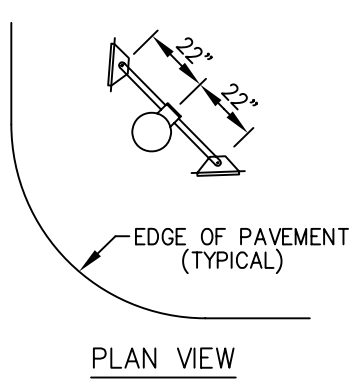

PLAN VIEW

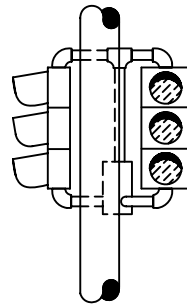

USE A TWO WAY FRAME FOR INSTALLING TWO FACES

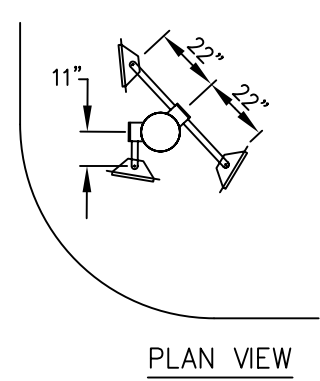

PLAN VIEW

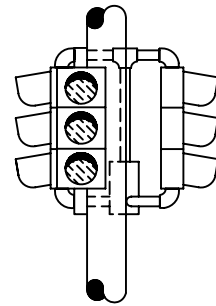

USE TWO FRAMES FOR INSTALLING THREE FACES: A TWO WAY AND A ONE WAY R.O.D.

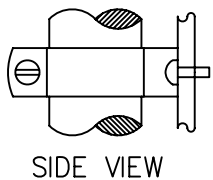
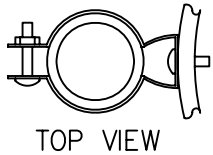

CONDUIT HANGER CLAMP

BOLTED TO THE SIGNAL POLE, 6" TO 12" BELOW THE TOP MOST 90° BEND

USE THE DOOR OF THE TERMINAL COMPARTMENT AS THE REFERENCE POINT FOR ALL FRAMEWORK DESIGNATIONS

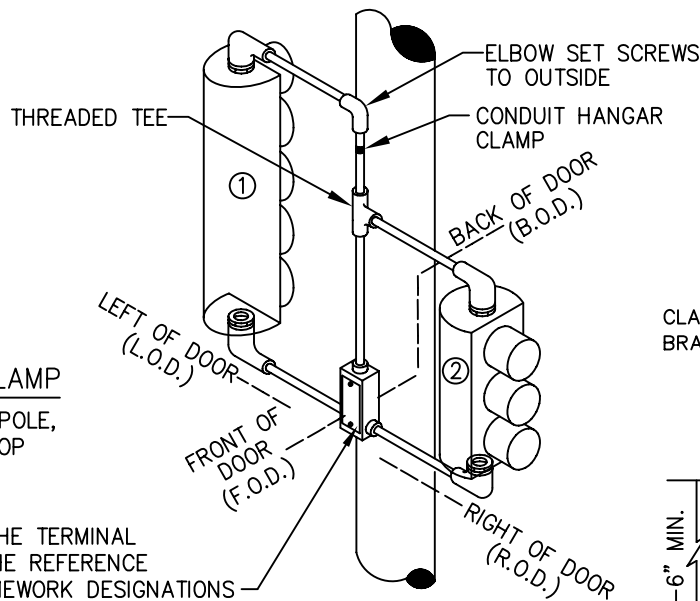

FRAMEWORK DESCRIPTION

HEAD NO. 1 OFFSET L.O.D.
HEAD NO. 2 OFFSET R.O.D.

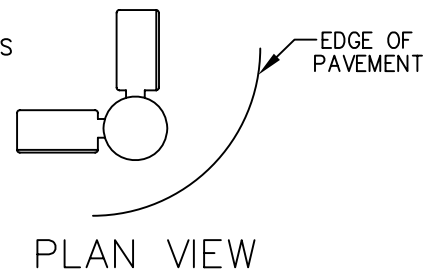

PLAN VIEW

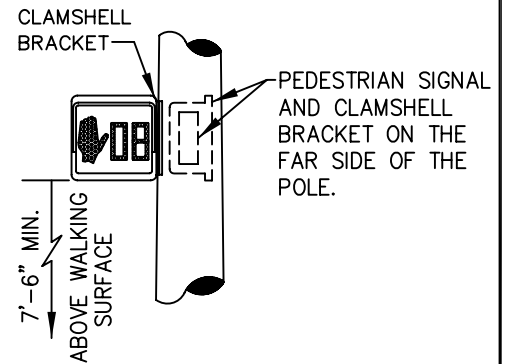

PEDESTRIAN SIGNAL

NOTE: SHOWN WITHOUT BACKPLATES

MUNICIPALITY



OF ANCHORAGE

SCALE:
NTS

APPROVED:

REVISED:
10/07

**SIDE-MOUNTED SIGNAL
DETAILS**

SECTION #
80.19

DETAIL #
80-27

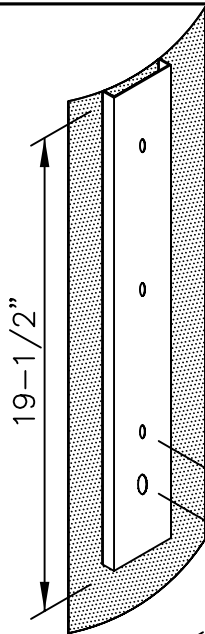

NOTE:
TAP TOP AND
BOTTOM SIGN
ATTACHMENT WITH
STAINLESS STEEL
BOLTS INTO THE
POLE.

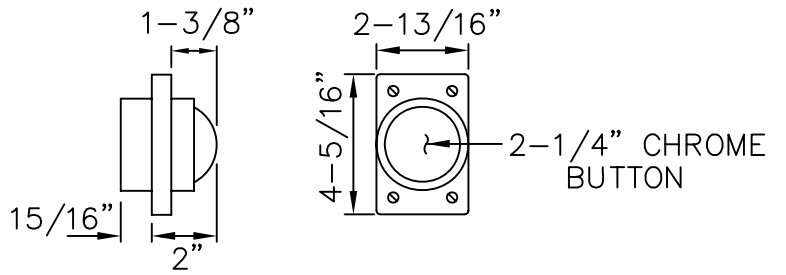

PEDESTRIAN PUSH BUTTON SWITCH

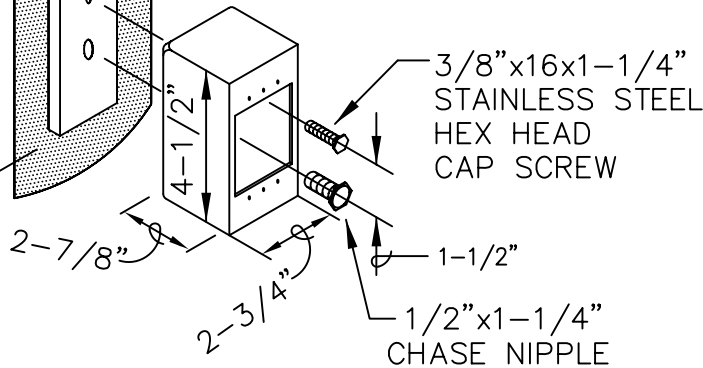

PEDESTRIAN BUTTON
HOUSING DETAIL

PEDESTRIAN SIGNAL AND
CLAMSHELL BRACKET ON
THE FAR SIDE OF THE POLE

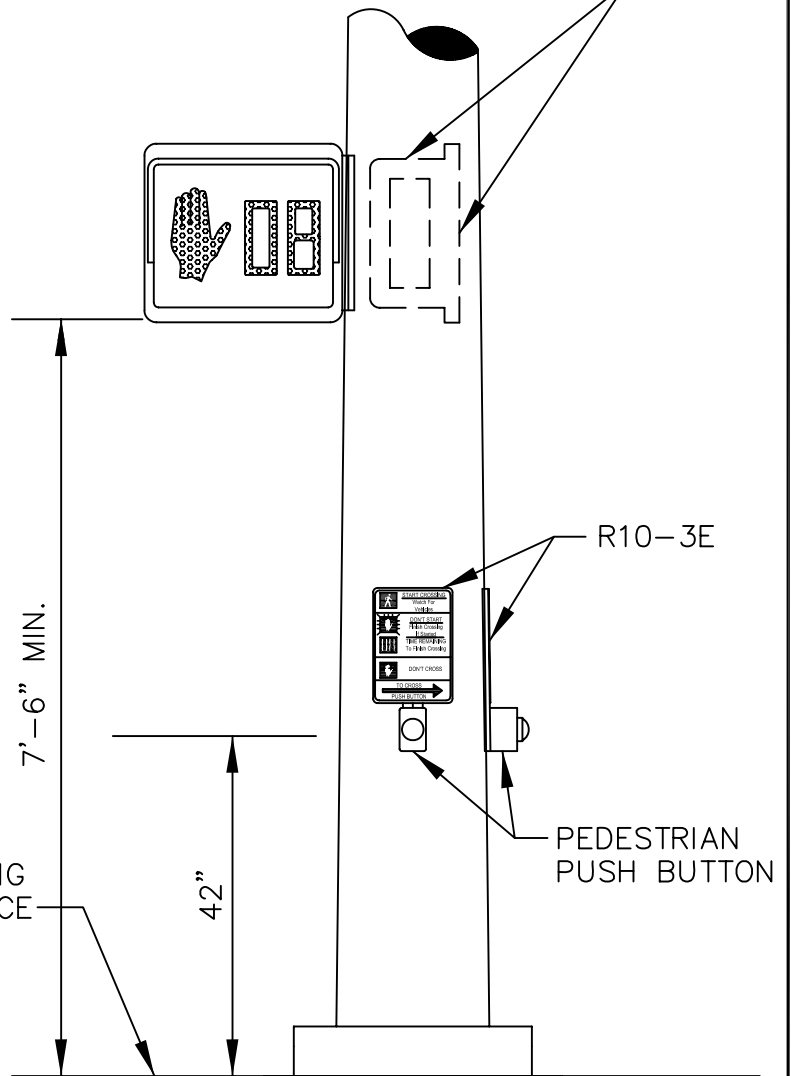

PEDESTRIAN HARDWARE

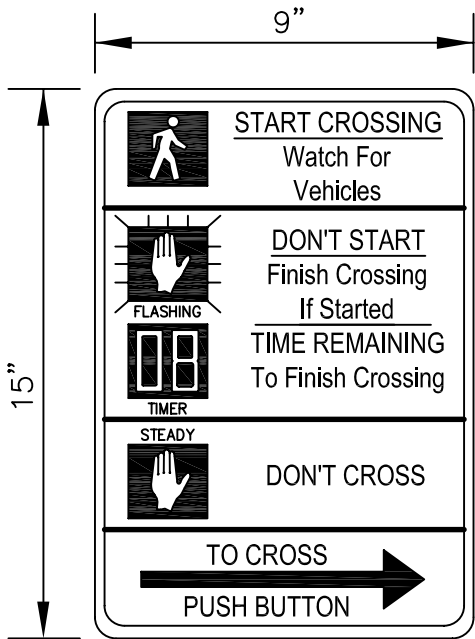

R10-3E
SIGN DETAIL

MUNICIPALITY

OF ANCHORAGE

SCALE:
NTS
APPROVED:

REVISED:
6/08

**PEDESTRIAN PUSH BUTTON
ASSEMBLY**

SECTION #
80.21
DETAIL #
80-28

3/8" STAINLESS STEEL BOLT
WASHERS, AND NUTS

PELCO "ASTRO BRACKET" CLAMP KIT WITH
PLUMBERIZER MOUNT (PART NO. AB-3007-L)
INSTALL WITH STAINLESS UPGRADE OPTION
(L INDICATES THE LENGTH OF THE STRAPS)

BRACKET STRAP

MAST ARM

2" GALVANIZED
RIGID METAL CONDUIT

ELEVATOR
PLUMBIZER

ELEVATOR PLUMBIZER

3-1/5"
MIN.

11"
MIN.

4-1/2"
SLIP-FITTER

TWO ROWS OF THREE
SQUARE HEAD SET SCREWS

TERMINAL COMPARTMENT
WITH SLIP FITTER

SERRATED
FITTING

4-1/2"
SLIP-FITTER

TWO ROWS OF THREE
SQUARE HEAD SET SCREWS

SLIP FITTER

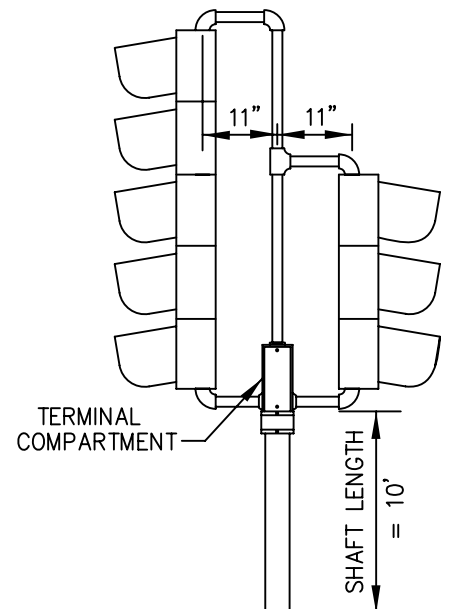
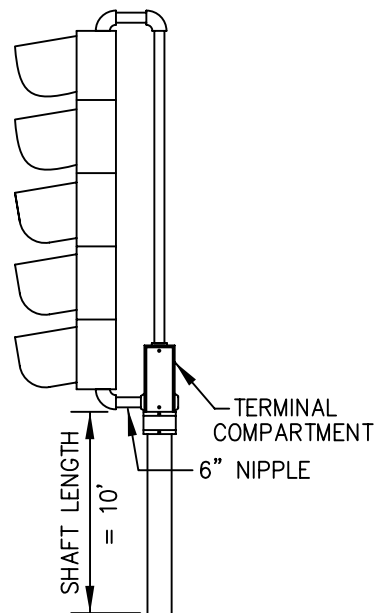
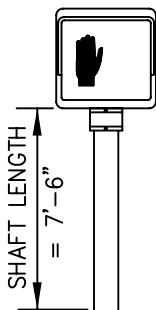

POST TOP MOUNTED SIGNAL DETAILS
(SHOWN WITHOUT BACKPLATES)

MUNICIPALITY



OF ANCHORAGE

SCALE:
NTS

APPROVED:

REVISED:
10/07

POST TOP AND MAST ARM MOUNTED SIGNAL DETAILS

SECTION #
80.19

DETAIL #
80-29

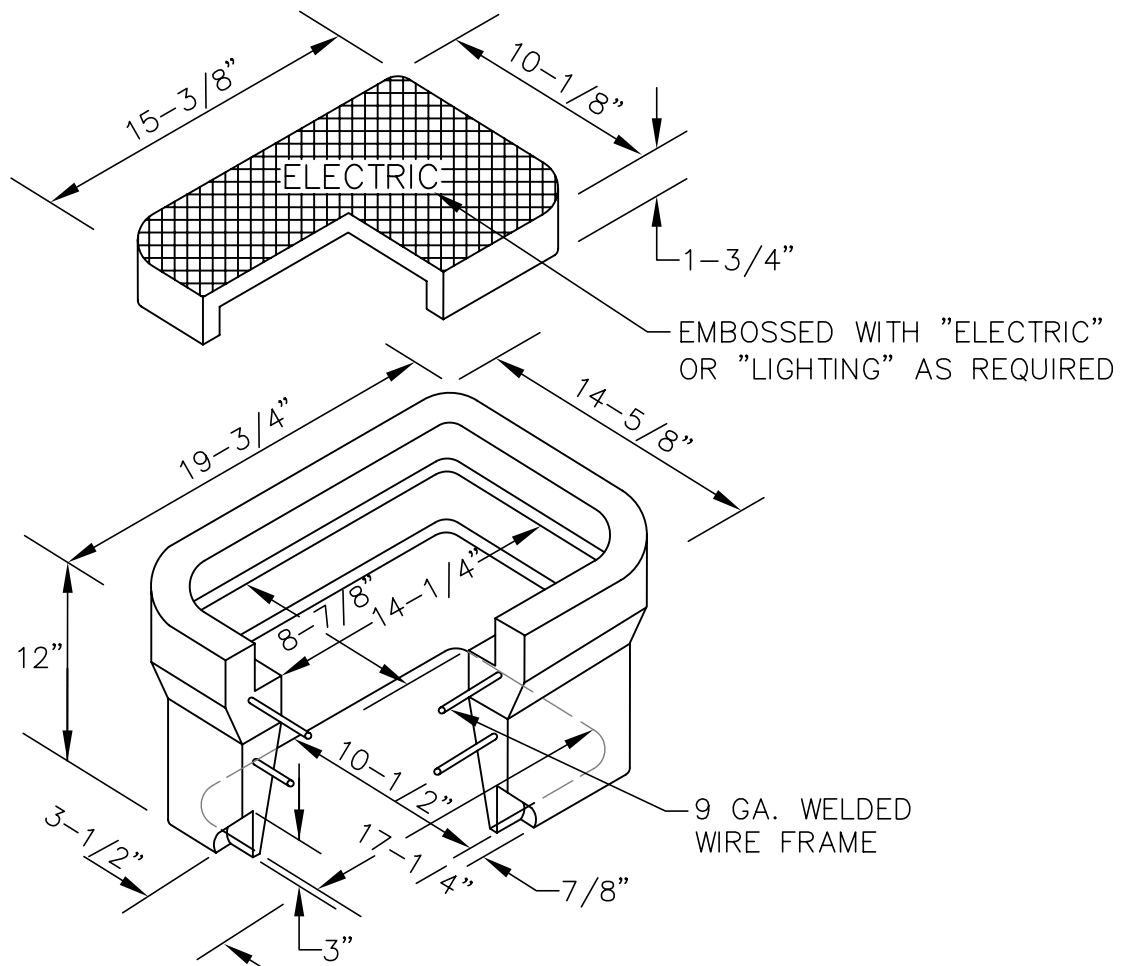

EMBOSSED WITH "ELECTRIC" OR "LIGHTING" AS REQUIRED

9 GA. WELDED WIRE FRAME

ATTACH GROUND BRAID TO LID USING STAINLESS STEEL NUT AND BOLT

3' COPPER BOND BRAID W/EYELETS @ 6" INTERVALS

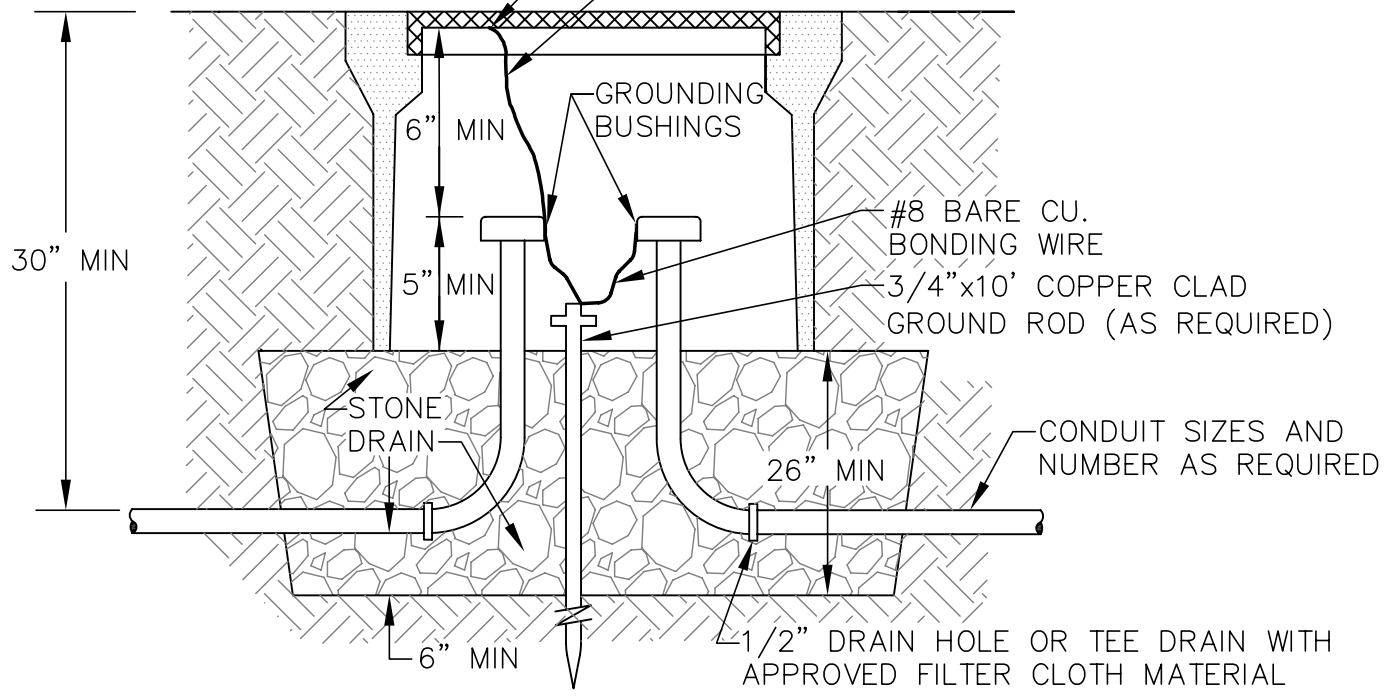

#8 BARE CU. BONDING WIRE
3/4" x 10' COPPER CLAD GROUND ROD (AS REQUIRED)

CONDUIT SIZES AND NUMBER AS REQUIRED

1/2" DRAIN HOLE OR TEE DRAIN WITH APPROVED FILTER CLOTH MATERIAL

 <p>MUNICIPALITY OF ANCHORAGE</p>	<p>SCALE: NTS</p> <p>APPROVED:</p> <p>REVISED: 6/08</p>	<h1>TYPE 1 JUNCTION BOX</h1>	<p>SECTION # 80.08</p> <p>DETAIL # 80-30</p>
--	---	----------------------------------	--

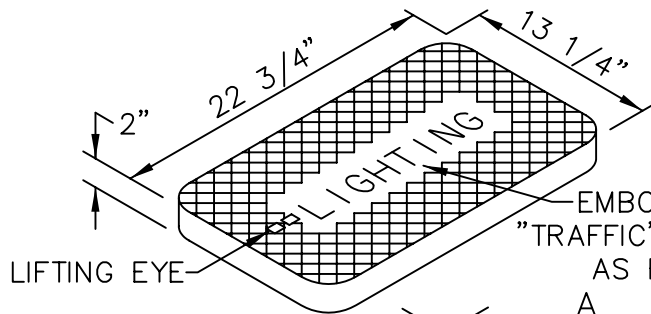

LIFTING EYE

EMBOSSED WITH
"TRAFFIC" OR "LIGHTING"
AS REQUIRED

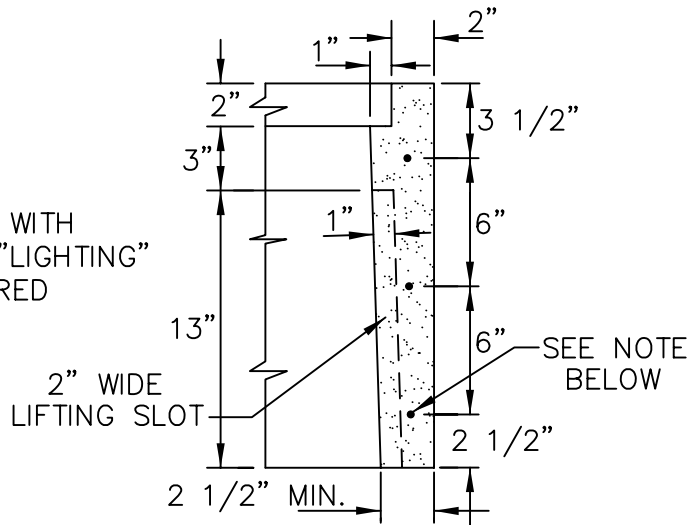

DETAIL A

NOTE: REINFORCEMENT MAY CONSIST OF;
 1. 9 GAGE WELDED WIRE FRAME.
 2. 3-6 GAGE HORIZONTAL WIRE LOOPS.
 3. SYNTHETIC FIBER REINFORCED CONCRETE THAT MEETS ASTM C 1116 AND CONTAINS FIBER IN PROPORTIONS AS RECOMMENDED BY THE FIBER MANUFACTURER.

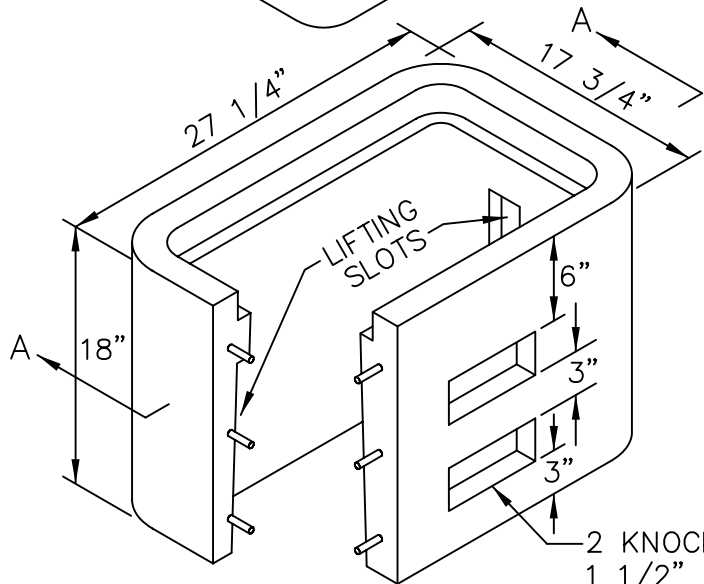

2 KNOCKOUTS CENTERED ON ONE SIDE
 1 1/2" DEEP x 3" HIGH x 7" WIDE
 FOR LOOP DETECTOR INSTALLATION

ATTACH GROUND BRAID TO LID USING
 STAINLESS STEEL NUT AND BOLT

4' BOND BRAID
 W/EYELETS AT 6"

SEE DETAIL A

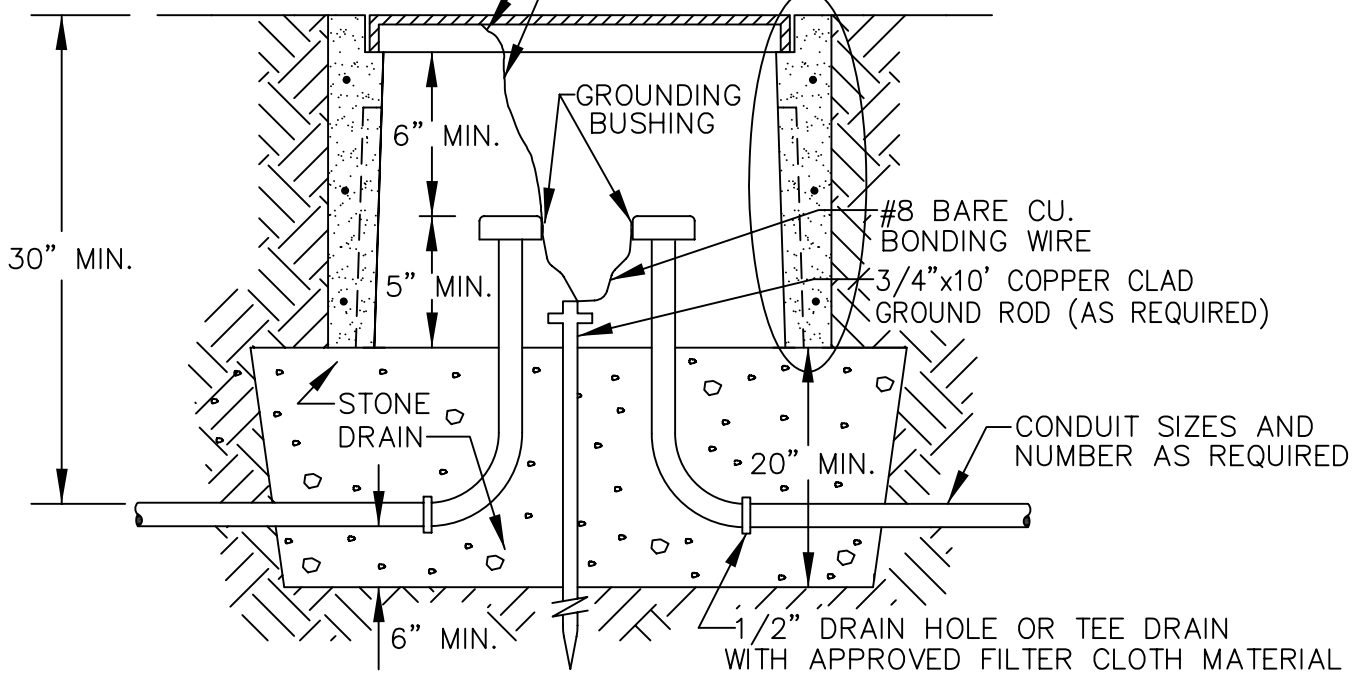

SECTION A-A

MUNICIPALITY



OF ANCHORAGE

SCALE:
 NTS

APPROVED:

REVISED:
 10/07

TYPE 1A JUNCTION BOX

SECTION #
 80.08

DETAIL #
 80-31

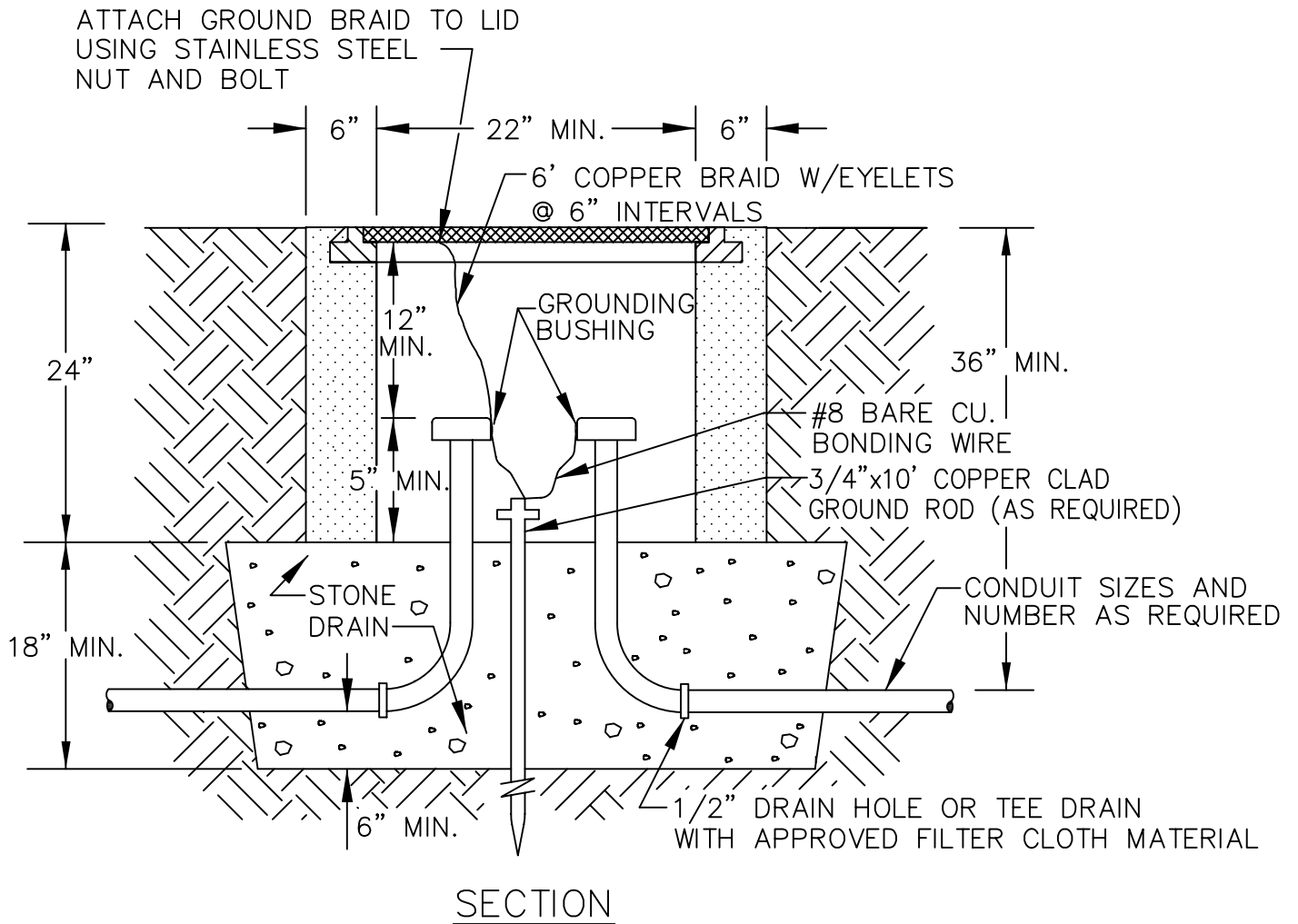
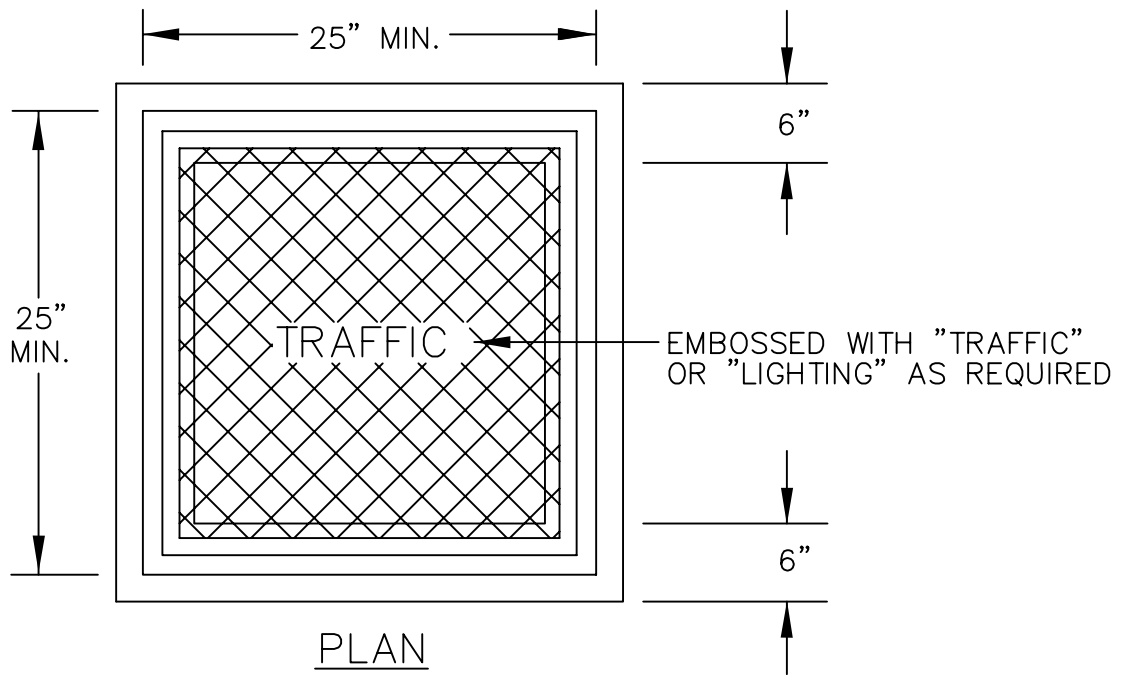

MUNICIPALITY



OF ANCHORAGE

SCALE:
NTS

APPROVED:

REVISED:
5/08

TYPE II JUNCTION BOX

SECTION #
80.08

DETAIL #
80-32

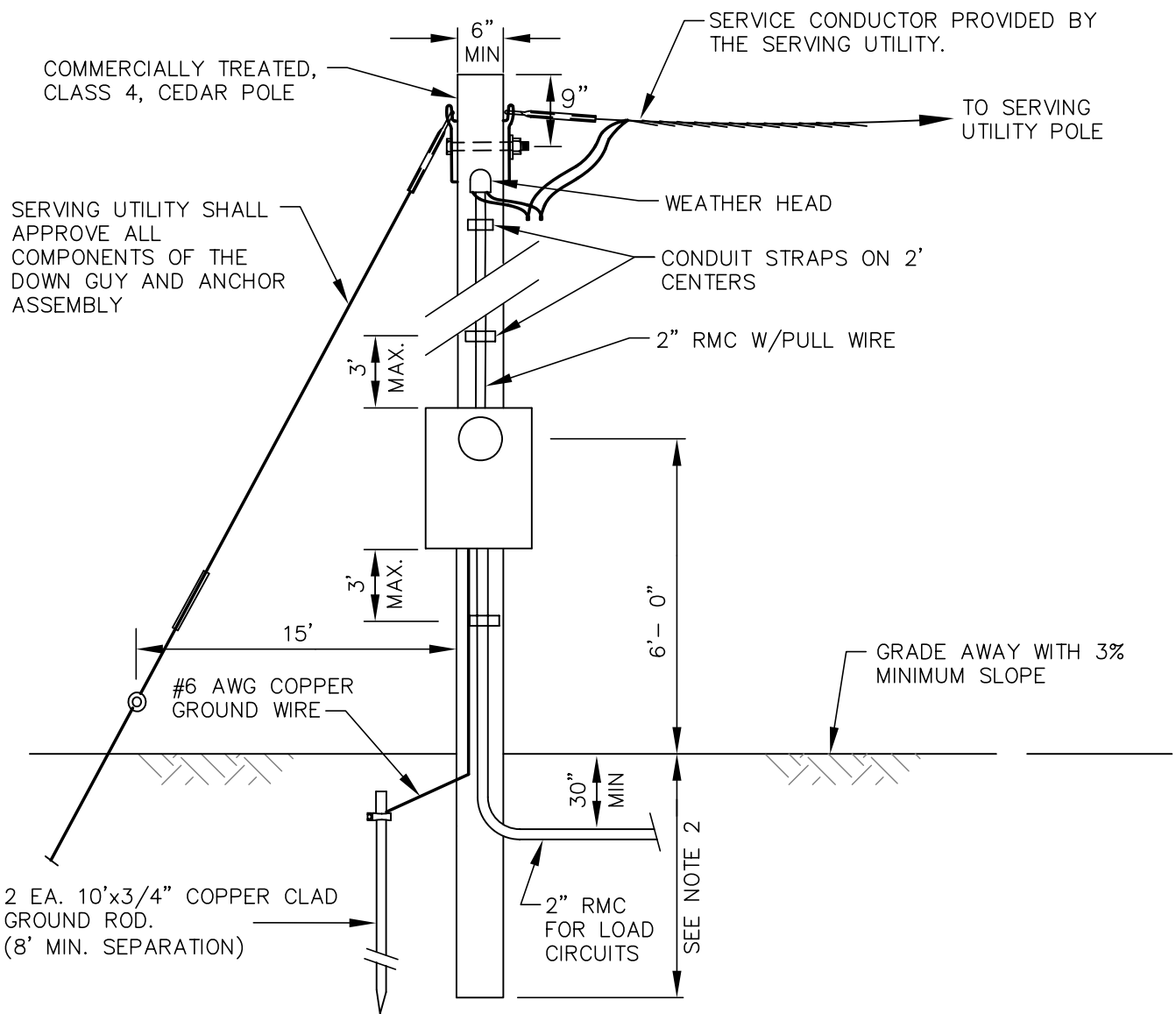

NOTES:

1. COORDINATE WITH SERVING UTILITY REGARDING SPECIFIC CONSTRUCTION REQUIREMENTS FOR SERVICE.
2. SET THE BUTT END OF TYPE 3 LOAD CENTER POLES TO THE FOLLOWING MINIMUM DEPTH:
 - A. 10 PERCENT OF ITS LENGTH PLUS 2 FEET, OR 5 FEET, WHICHEVER IS GREATER, IF IT IS INSTALLED IN EARTH OTHER THAN SOLID ROCK OR MUSKEG.
 - B. 10 PERCENT OF ITS LENGTH, OR 4 FEET, WHICHEVER IS GREATER, IF IT IS INSTALLED IN SOLID ROCK.
 - C. CONSIDER MUSKEG TO BE AIR, AND SET THE BUT ENDS TO THE DEPTH GIVEN IN A OR B, WHICHEVER APPLIES, IN THE UNDERLYING EARTH OR ROCK.
3. WHENEVER MORE THAN TWO FEET OF EARTH OVERLAYS ROCK, OR THE DIAMETER OF THE DRILLED HOLE IN ROCK EXCEEDS TWICE THE DIAMETER OF THE POLE AT THE GROUND LINE, CONSIDER THE INSTALLATION AS EARTH.

MUNICIPALITY



OF ANCHORAGE

SCALE:
NTS

APPROVED:

REVISED:
7/08

**POST MOUNTED LOAD
CENTER TYPE 3**

SECTION #
80.14

DETAIL #
80-34

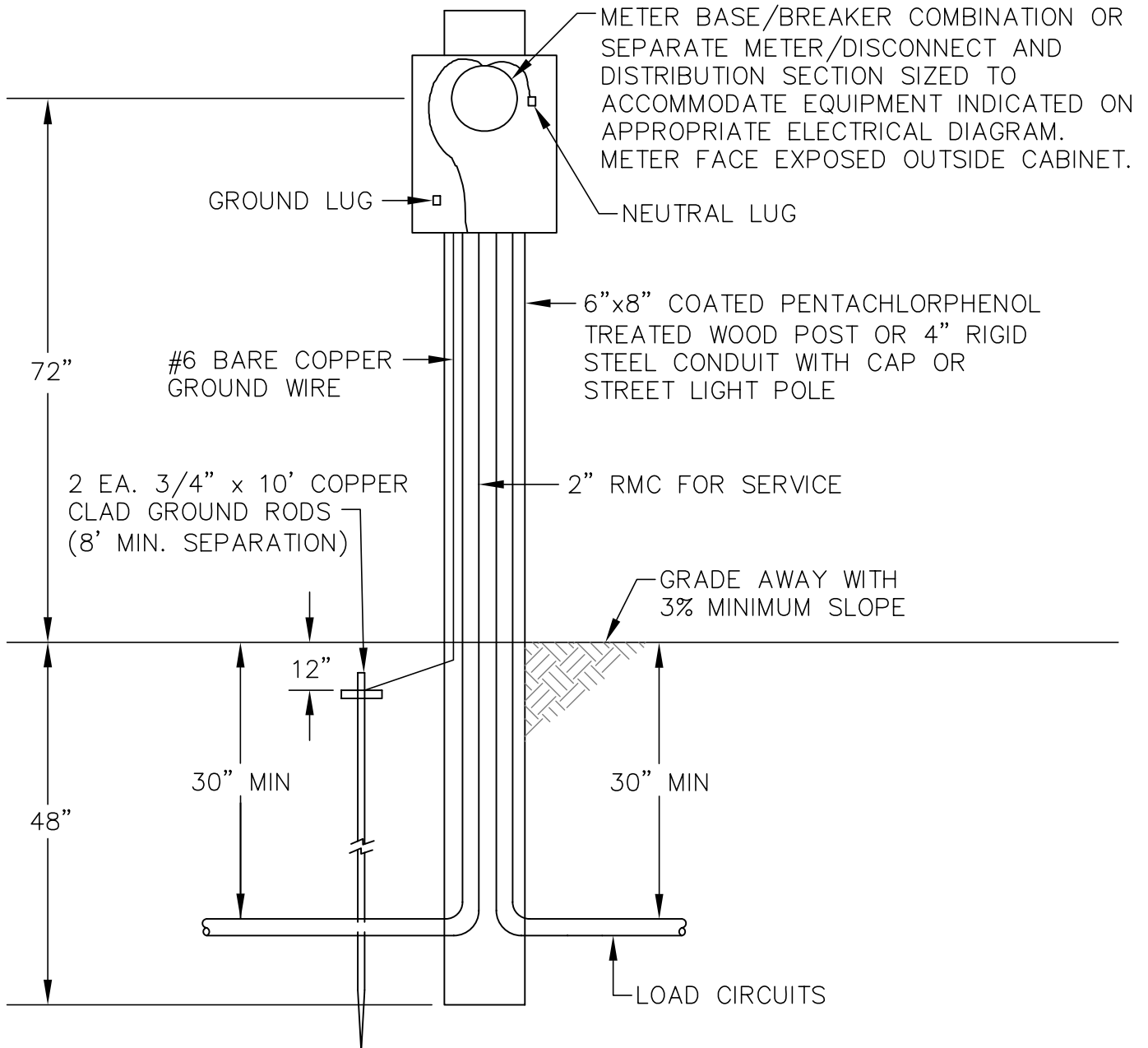

NOTES:

1. ATTACH CONDUITS TO POLE AT 24" INTERVALS.
2. ATTACH GROUND WIRE TO POLE AT 12" INTERVALS.
3. ON STEEL POST, ENCLOSE GROUND WIRE IN 3/4" RMC, BOND EACH END OF CONDUIT TO GROUND WIRE.
4. EMBED LOWER 42" OF STEEL POST IN CONCRETE HAVING A MINIMUM 18" OVERALL DIA. BACKFILL AROUND WOOD POST WITH N.F.S. MATERIAL.
5. LOCATE OUT OF DITCH LINE, 5 FT. MINIMUM FROM BACK OF CURB.
6. COORDINATE WITH SERVING UTILITY REGARDING SPECIFIC CONSTRUCTION REQUIREMENTS FOR SERVICE.

MUNICIPALITY



OF ANCHORAGE

SCALE:
NTS

APPROVED:

REVISED:
7/08

POST MOUNTED LOAD CENTER - TYPE 2

SECTION #
80.14

DETAIL #
80-35

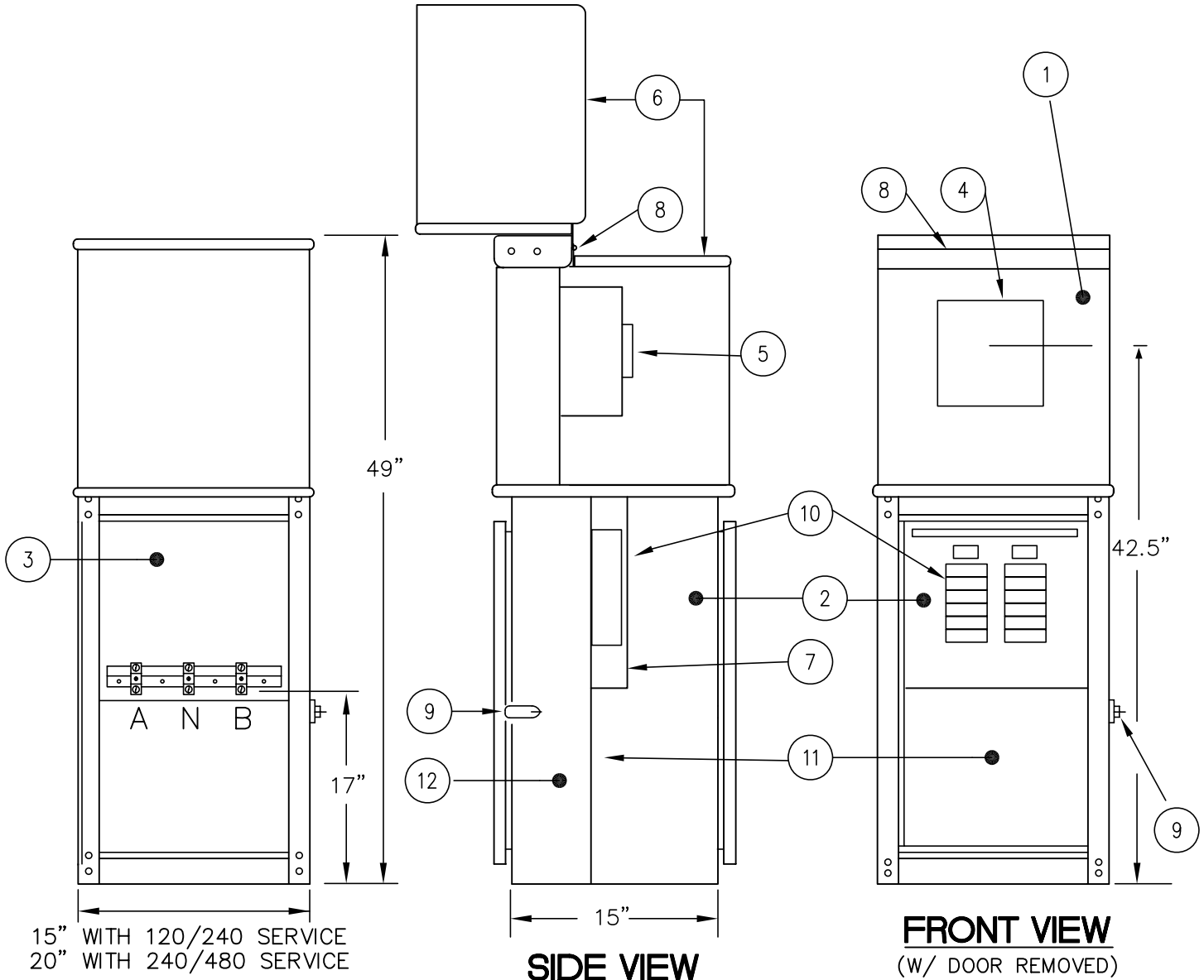

15" WITH 120/240 SERVICE
 20" WITH 240/480 SERVICE

REAR VIEW
 (W/ DOOR REMOVED)

SIDE VIEW
 (W/ METER SECTION OPEN)

FRONT VIEW
 (W/ DOOR REMOVED)

EQUIPMENT LEGEND/DESCRIPTION

- | | |
|--|--|
| 1. METERING SECTION | 7. DEADFRONT |
| 2. LOAD SECTION | 8. STAINLESS STEEL PIN HINGE |
| 3. UTILITY CONNECTION AND TEST BLOCK SECTION | 9. PADLOCKING PROVISIONS |
| 4. METER READING WINDOW (8"X8") | 10. DISTRIBUTION PANEL W/ MAIN BREAKER |
| 5. METER SOCKET W/BYPASS & SAFETY SOCKET | 11. ACCESSORY MOUNTING EQUIPMENT AREA |
| 6. LIFT AWAY METER SECTION COVER | 12. SERVICE PULL SECTION. |



SCALE:
NTS
 APPROVED:
 REVISED:
7/08

PAD MOUNTED LOAD CENTER - TYPE 1A

SECTION #
80.14
 DETAIL #
80-36

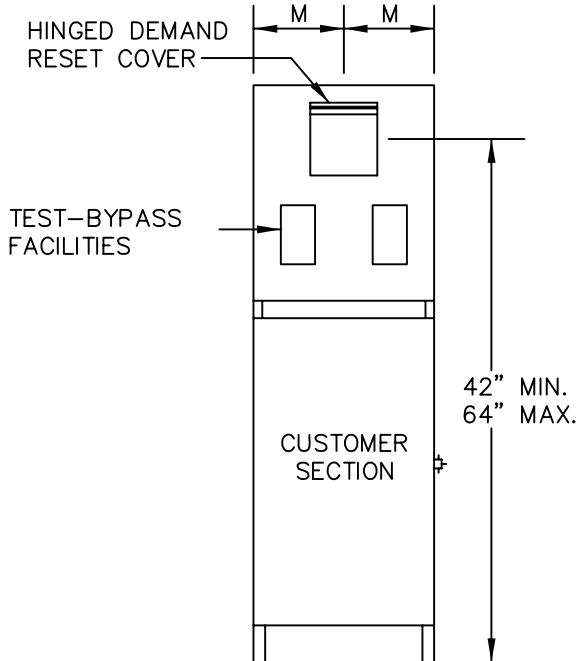

FRONT VIEW

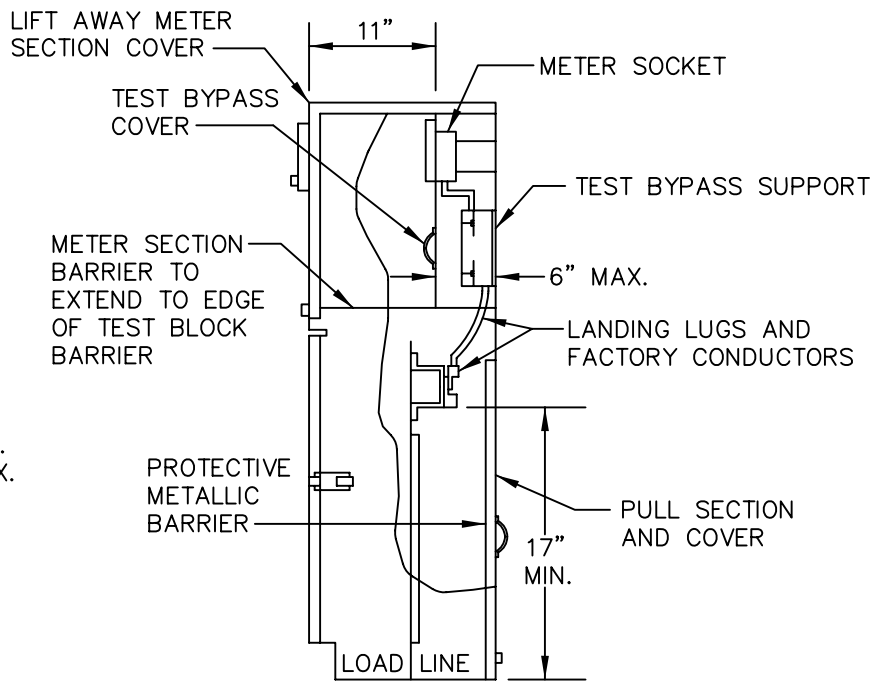

SIDE VIEW

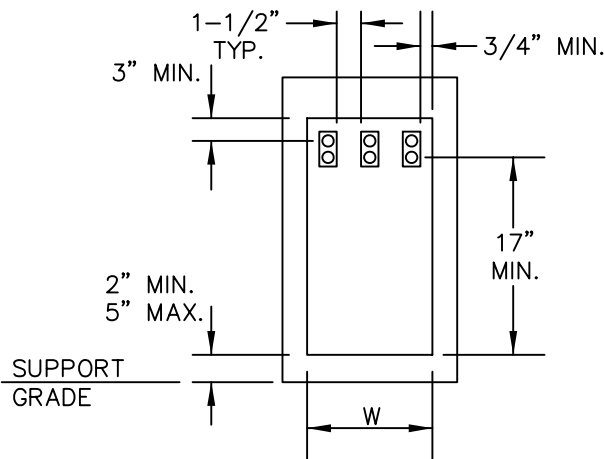

WIREWAY PULL SECTION

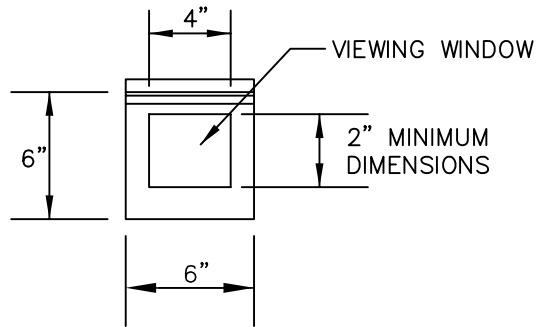

HINGED DEMAND RESET WITH POLYCARBONATE VIEWING

MINIMUM DIMENSIONS

SERVICE	W	A
1 PHASE	10-1/2"	10"
3 PHASE	12-1/2"	



SCALE:
NTS
APPROVED:
REVISD:
10/07

PAD MOUNTED LOAD CENTER - TYPE 1

SECTION #
80.14
DETAIL #
80-37

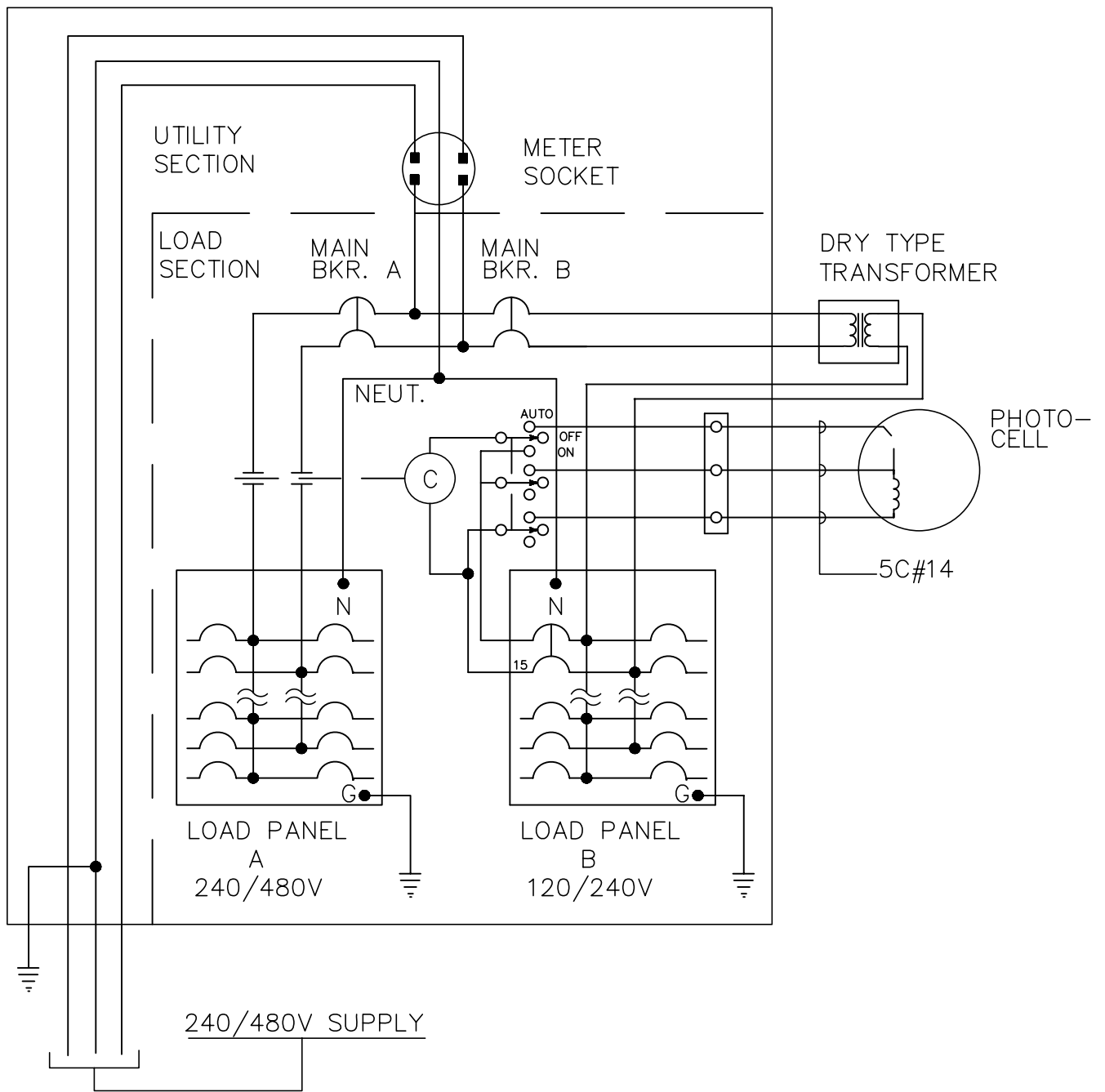

NOTE:

1. SEE PANEL SCHEDULE, STANDARD DETAIL 80-39

MUNICIPALITY



OF ANCHORAGE

SCALE:
NTS

APPROVED:

REVISED:
10/07

LOAD CENTER WIRING DIAGRAM "A"

SECTION #
80.14

DETAIL #
80-38

LOAD CENTER NO. _____ TYPE _____
 LOCATION _____
 240/480 VOLTS, SINGLE PHASE, _____ AMP SUPPLY
 _____ AMPS INTERRUPTING CURRENT
 MAIN BREAKER A : 2 POLE, _____ AMPS, 480 VOLTS
 MAIN BREAKER B : 2 POLE, _____ AMPS, 240 VOLTS
 CONTACTOR RATING: _____ AMPS
 TRANSFORMER RATING: 120/240-240/480., _____ KVA

PANEL A _____ 240/480 VOLTS _____ SINGLE PHASE _____ 3 WIRE
 _____ AMPS MAIN LUGS, _____ AMPS INTERRUPT CAPACITY

CKT. DESCRIPTION	KVA	AMP			AMP	KVA	CKT. DESCRIPTION
			1	2			
			3	4			
			5	6			
			7	8			
			9	10			
			11	12			
			13	14			
			15	16			
			17	18			
			19	20			

PANEL B _____ 120/240 VOLTS _____ SINGLE PHASE _____ 3 WIRE
 _____ AMPS MAIN LUGS, _____ AMPS INTERRUPT CAPACITY

CKT. DESCRIPTION	KVA	AMP			AMP	KVA	CKT. DESCRIPTION
PHOTO CELL ↓	0.1	15	1	2			
			3	4			
			5	6			
			7	8			
			9	10			
			11	12			
			13	14			
			15	16			
			17	18			
			19	20			

NOTE: SEE CONSTRUCTION DRAWINGS FOR NUMBER & SIZE OF BREAKERS.

<p>MUNICIPALITY OF ANCHORAGE</p>	SCALE: NTS APPROVED: REVISED: 10/07	<h2>PANEL SCHEDULE FOR WIRING DIAGRAM "A"</h2>	SECTION # 80.14 DETAIL # 80-39
--------------------------------------	---	--	---

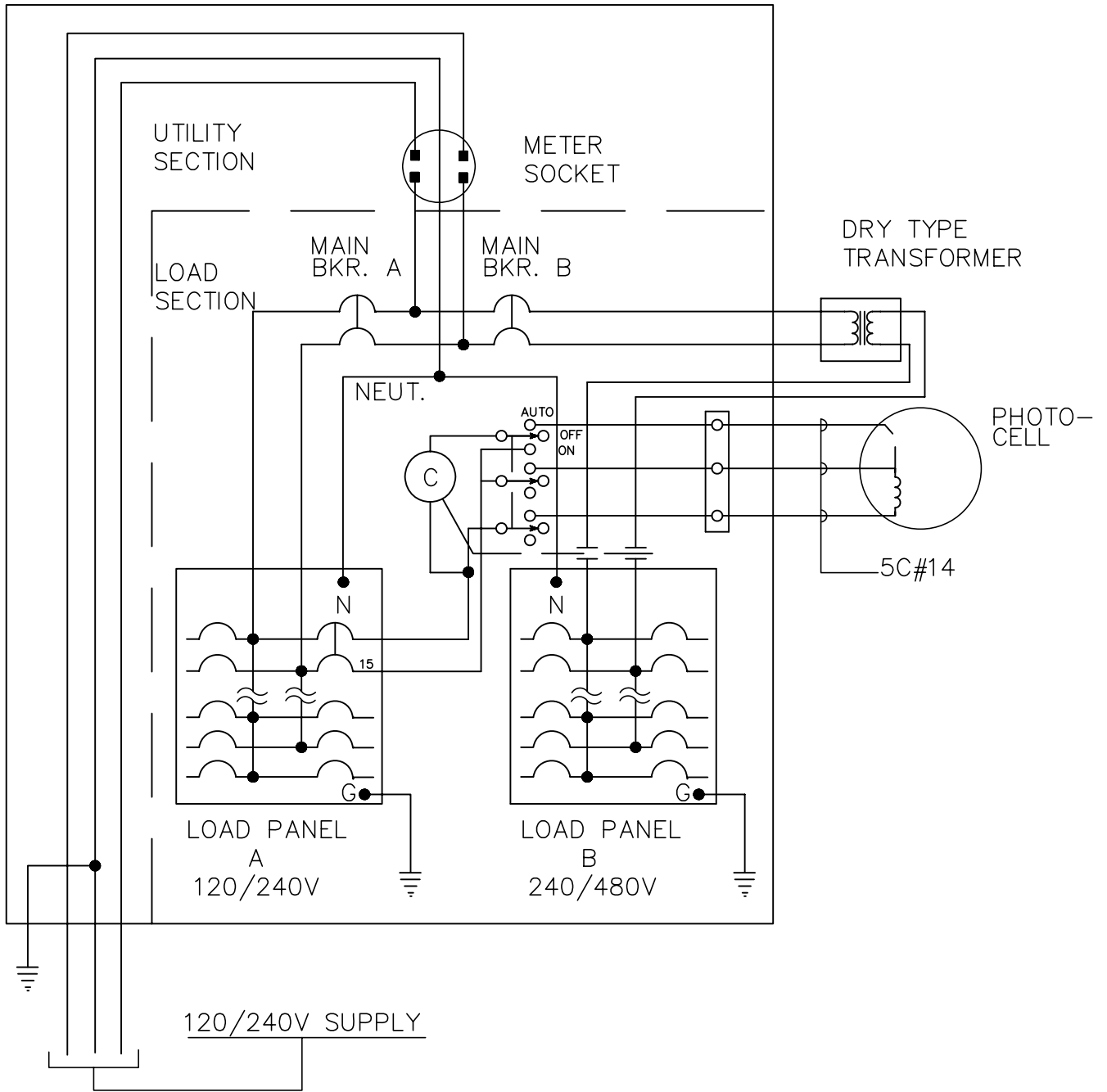

NOTE:

1. SEE PANEL SCHEDULE, STANDARD DETAIL 80-41

MUNICIPALITY



OF ANCHORAGE

SCALE:
NTS

APPROVED:

REVISED:
10/07

LOAD CENTER WIRING DIAGRAM "B"

SECTION #
80.14

DETAIL #
80-40

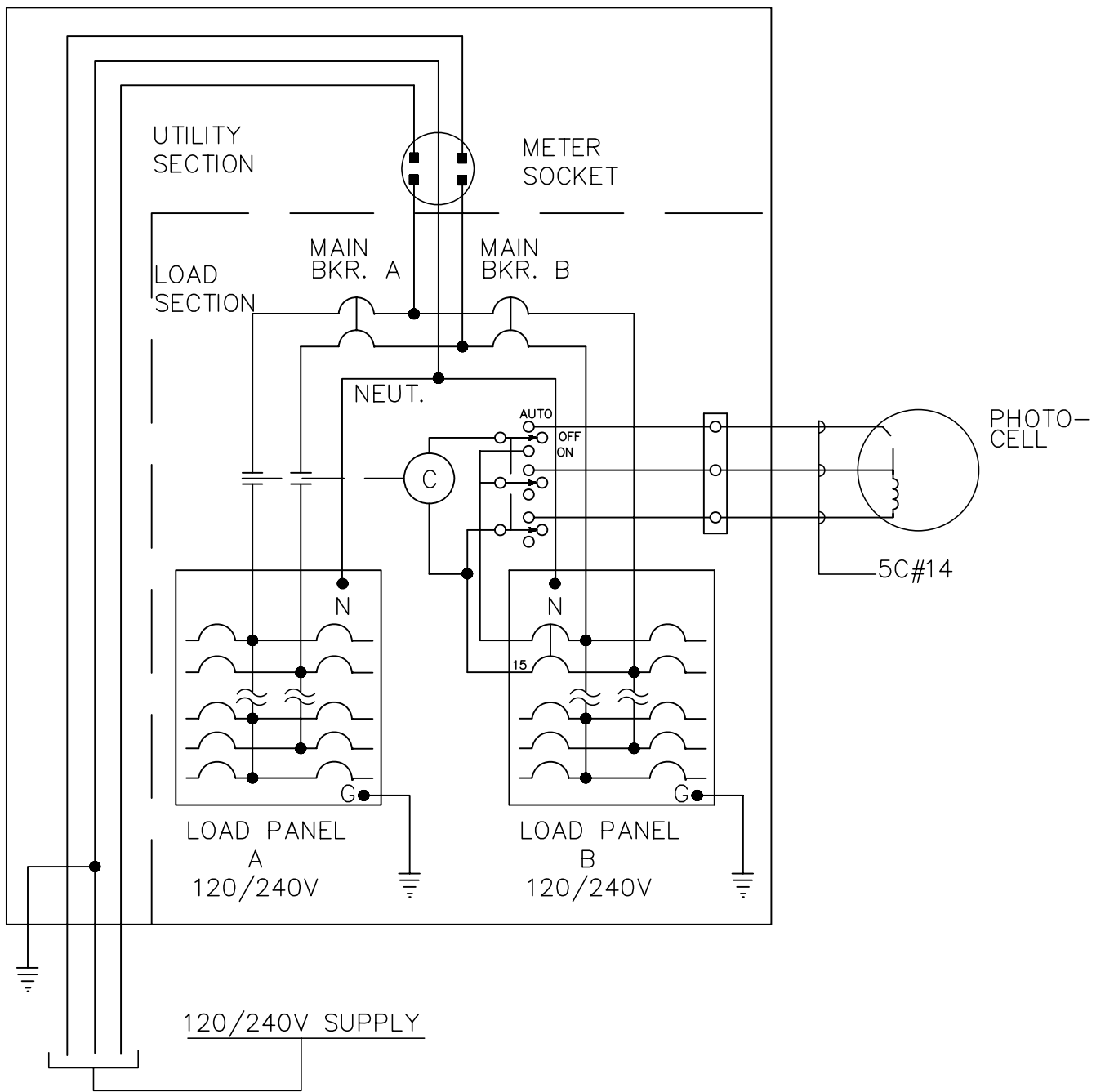

NOTE:

1. SEE PANEL SCHEDULE, STANDARD DETAIL 80-43

MUNICIPALITY



OF ANCHORAGE

SCALE:
NTS

APPROVED:

REVISED:
10/07

LOAD CENTER WIRING DIAGRAM "C"

SECTION #
80.14

DETAIL #
80-42

LOAD CENTER NO. _____ TYPE _____

LOCATION _____

120/240 VOLTS, SINGLE PHASE, _____ AMP SUPPLY

_____ AMPS INTERRUPTING CURRENT

MAIN BREAKER A : 2 POLE, _____ AMPS, 240 VOLTS

MAIN BREAKER B : 2 POLE, _____ AMPS, 240 VOLTS

CONTACTOR RATING: _____ AMPS, 240 VOLTS

PANEL A _____ 120/240 VOLTS _____ SINGLE PHASE 3 WIRE
 _____ AMPS MAIN LUGS, _____ AMPS INTERRUPT CAPACITY

CKT. DESCRIPTION	KVA	AMP			AMP	KVA	CKT. DESCRIPTION
			1	2			
			3	4			
			5	6			
			7	8			
			9	10			
			11	12			
			13	14			
			15	16			
			17	18			
			19	20			

PANEL B _____ 120/240 VOLTS _____ SINGLE PHASE 3 WIRE
 _____ AMPS MAIN LUGS, _____ AMPS INTERRUPT CAPACITY

CKT. DESCRIPTION	KVA	AMP			AMP	KVA	CKT. DESCRIPTION
PHOTO CELL	0.1	15	1	2			
↓	↓	↓	3	4			
			5	6			
			7	8			
			9	10			
			11	12			
			13	14			
			15	16			
			17	18			
			19	20			

NOTE: SEE CONSTRUCTION DRAWINGS FOR NUMBER & SIZE OF BREAKERS.

MUNICIPALITY



OF ANCHORAGE

SCALE:
NTS

APPROVED:

REVISED:
10/07

PANEL SCHEDULE FOR WIRING DIAGRAM "C"

SECTION #
80.14

DETAIL #
80-43

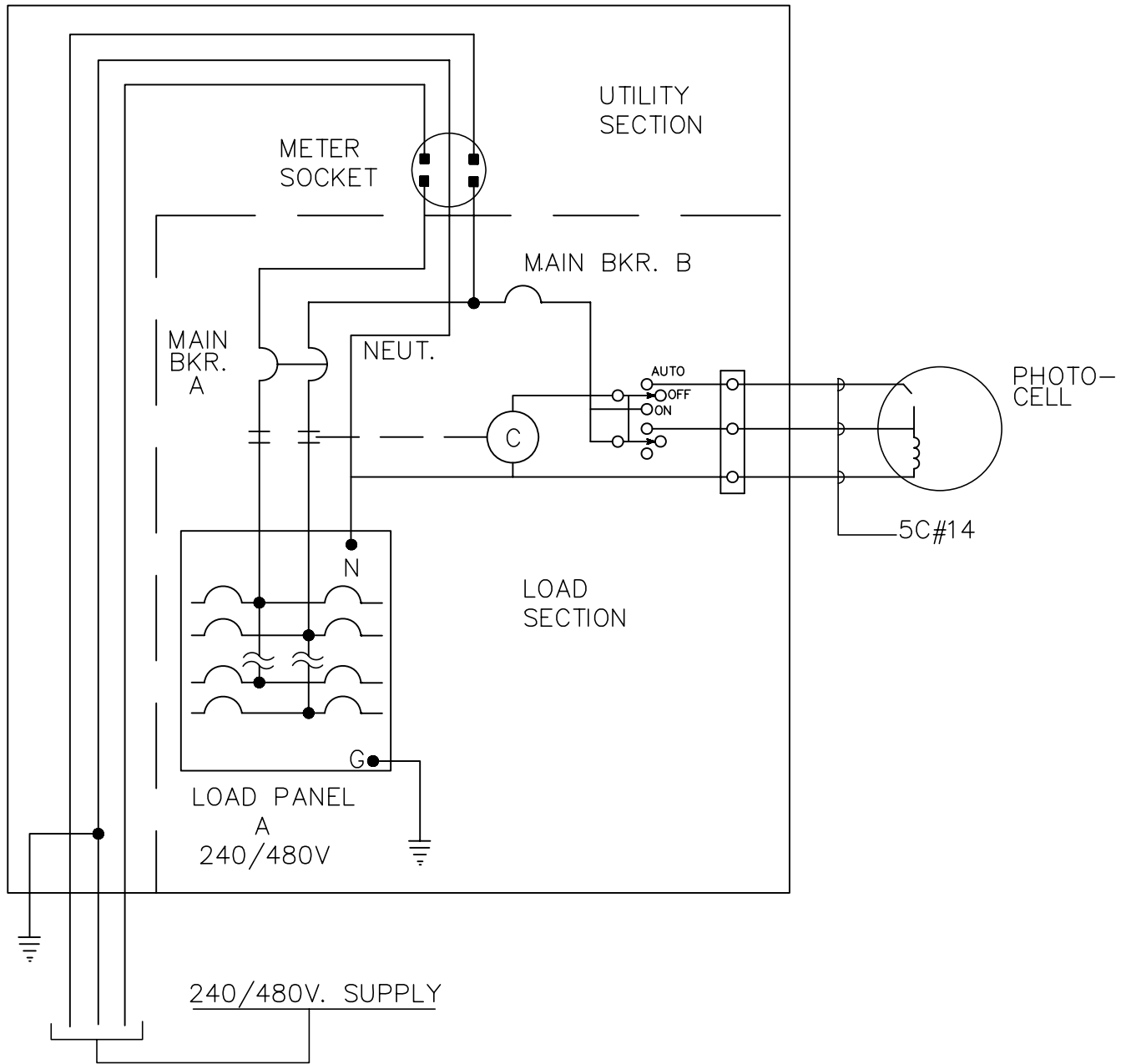

NOTE:

1. SEE PANEL SCHEDULE, STANDARD DETAIL 80-45

MUNICIPALITY



OF ANCHORAGE

SCALE:
NTS

APPROVED:

REVISED:
10/07

LOAD CENTER WIRING DIAGRAM "D"

SECTION #
80.14

DETAIL #
80-44

LOAD CENTER NO. _____ TYPE _____

LOCATION _____

240/480 VOLTS, SINGLE PHASE, _____ AMP SUPPLY

_____ AMPS INTERRUPTING CURRENT

MAIN BREAKER A : 2 POLE, _____ AMPS, 480 VOLTS

MAIN BREAKER B : 1 POLE, _____ 15 _____ AMPS, 240 VOLTS

CONTACTOR RATING: _____ AMPS, 240 VOLTS

PANEL A _____ 240/480 VOLTS _____ SINGLE _____ PHASE _____ 3 _____ WIRE
 _____ AMPS MAIN LUGS, _____ AMPS INTERRUPT CAPACITY

CKT. DESCRIPTION	KVA	AMP			AMP	KVA	CKT. DESCRIPTION
			1	2			
			3	4			
			5	6			
			7	8			
			9	10			
			11	12			
			13	14			
			15	16			
			17	18			
			19	20			

NOTE: SEE CONSTRUCTION DRAWINGS FOR NUMBER & SIZE OF BREAKERS.

MUNICIPALITY



OF ANCHORAGE

SCALE:
NTS

APPROVED:

REVISED:
10/07

PANEL SCHEDULE FOR WIRING DIAGRAM "D"

SECTION #
80.14

DETAIL #
80-45

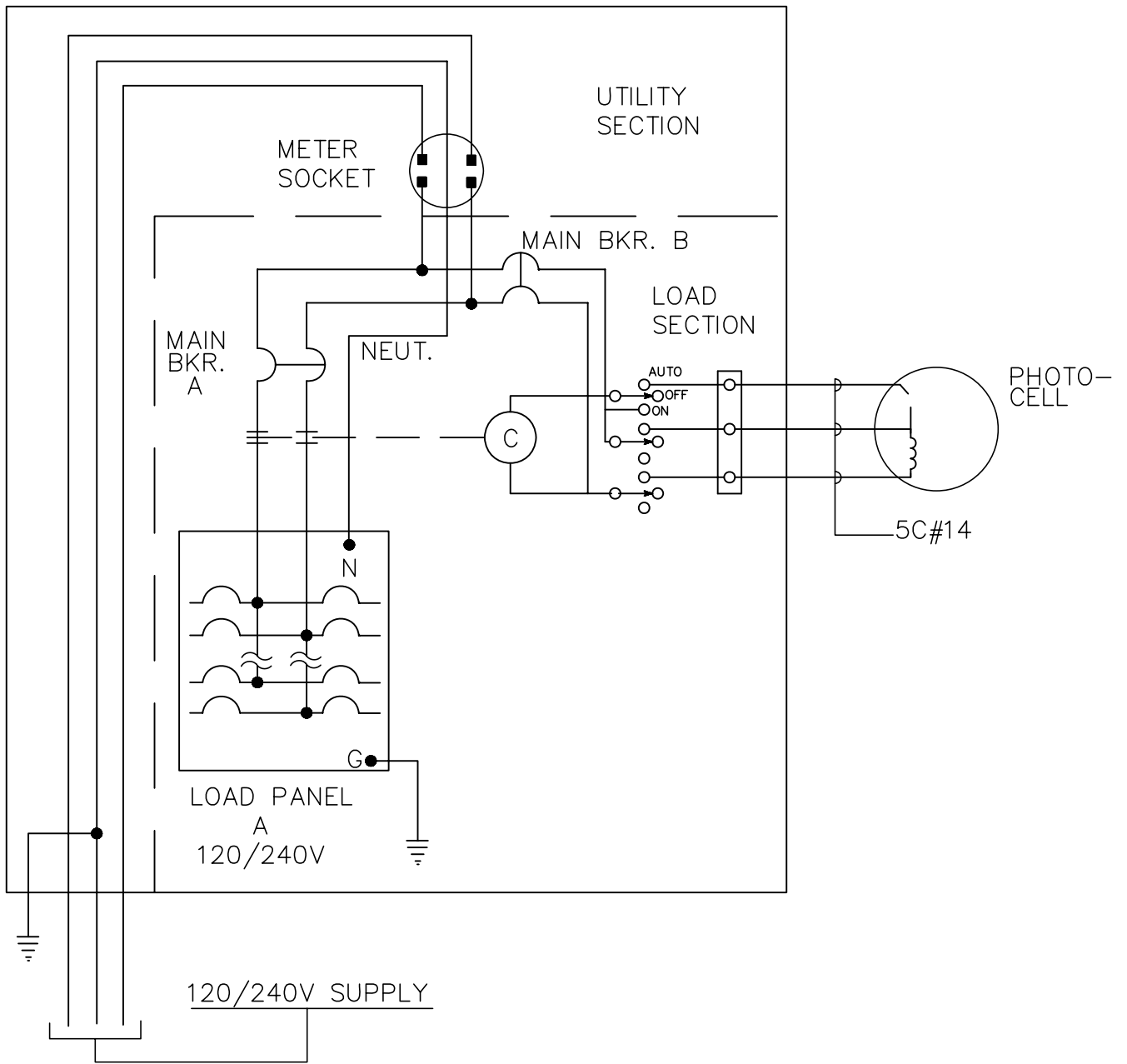

NOTE:

1. SEE PANEL SCHEDULE, STANDARD DETAIL 80-47

MUNICIPALITY



OF ANCHORAGE

SCALE:
NTS

APPROVED:

REVISED:
10/07

LOAD CENTER WIRING DIAGRAM "E"

SECTION #
80.14

DETAIL #
80-46

LOAD CENTER NO. _____ TYPE: _____

LOCATION: _____

120/240 VOLTS, SINGLE PHASE, _____ AMP SUPPLY

_____ AMPS INTERRUPTING CURRENT

MAIN BREAKER A : 2 POLE, _____ AMPS, 240 VOLTS

MAIN BREAKER B : 2 POLE, _____ 15 _____ AMPS, 240 VOLTS

CONTACTOR RATING: _____ AMPS

PANEL A _____ 120/240 VOLTS _____ SINGLE PHASE 3 WIRE
 _____ AMPS MAIN LUGS, _____ AMPS INTERRUPT CAPACITY

CKT. DESCRIPTION	KVA	AMP			AMP	KVA	CKT. DESCRIPTION
			1	2			
			3	4			
			5	6			
			7	8			
			9	10			
			11	12			
			13	14			
			15	16			
			17	18			
			19	20			

NOTE: SEE CONSTRUCTION DRAWINGS FOR NUMBER & SIZE OF BREAKERS.

MUNICIPALITY



OF ANCHORAGE

SCALE:
NTS

APPROVED:

REVISED:
10/07

PANEL SCHEDULE FOR WIRING DIAGRAM "E"

SECTION #
80.14

DETAIL #
80-47

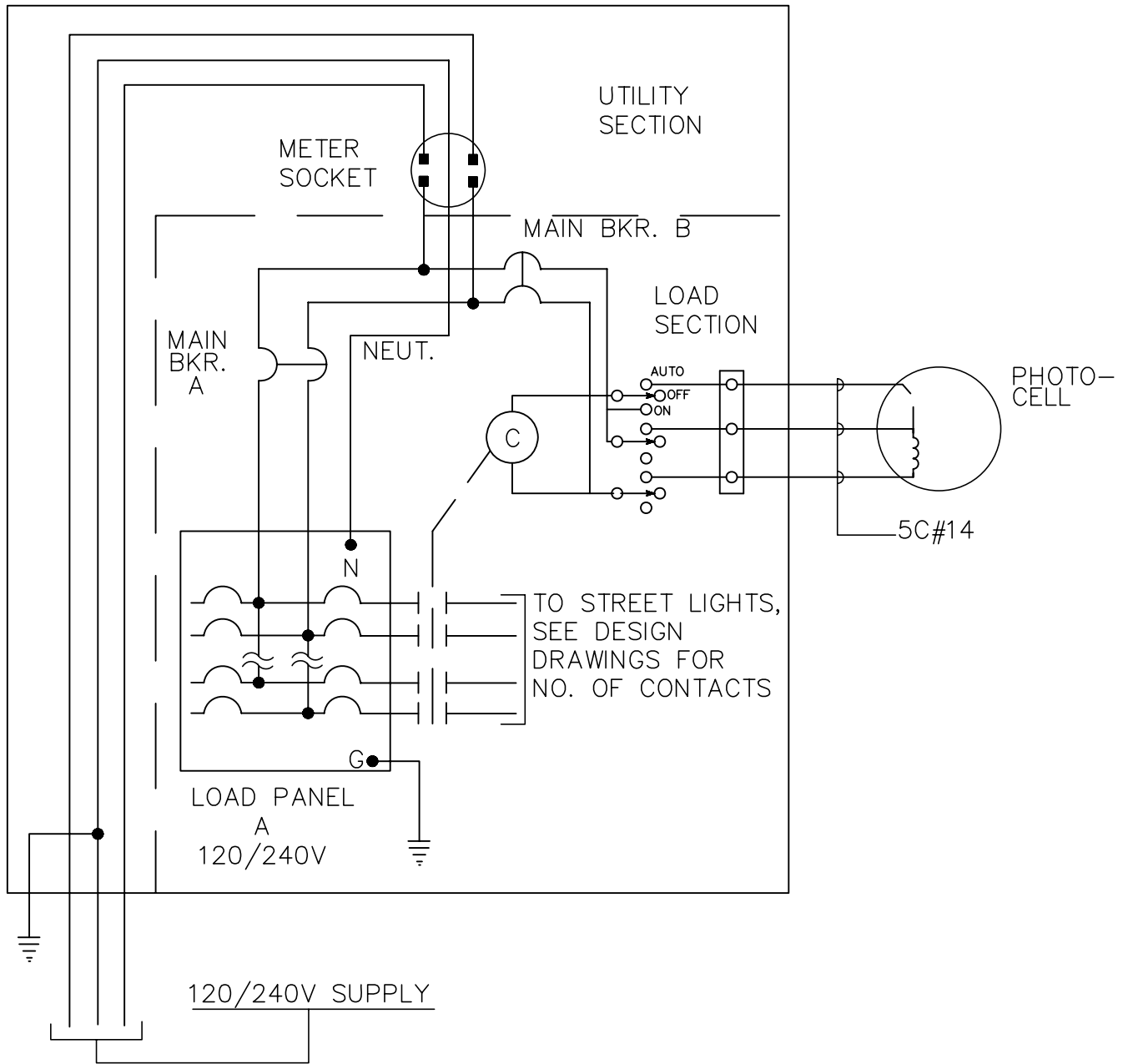

NOTE:

1. SEE PANEL SCHEDULE, STANDARD DETAIL 80-49

MUNICIPALITY



OF ANCHORAGE

SCALE:
NTS

APPROVED:

REVISED:
10/07

LOAD CENTER WIRING DIAGRAM "F"

SECTION #
80.14

DETAIL #
80-48

LOAD CENTER NO. _____ TYPE: _____

LOCATION: _____

_____ POLE, _____ AMP CONTACTOR

PANEL A _____ 120/240 VOLTS _____ SINGLE PHASE 3 WIRE
 _____ AMPS MAIN LUGS, _____ AMPS INTERRUPT CAPACITY

CKT. DESCRIPTION	KVA	AMP			AMP	KVA	CKT. DESCRIPTION
			1	2			
			3	4			
			5	6			
			7	8			
			9	10			
			11	12			
			13	14			
			15	16			
			17	18			
			19	20			

NOTE: SEE CONSTRUCTION DRAWINGS FOR NUMBER & SIZE OF BREAKERS.

MUNICIPALITY



OF ANCHORAGE

SCALE:
NTS

APPROVED:

REVISED:
10/07

PANEL SCHEDULE FOR WIRING DIAGRAM 'F'

SECTION #
80.14

DETAIL #
80-49

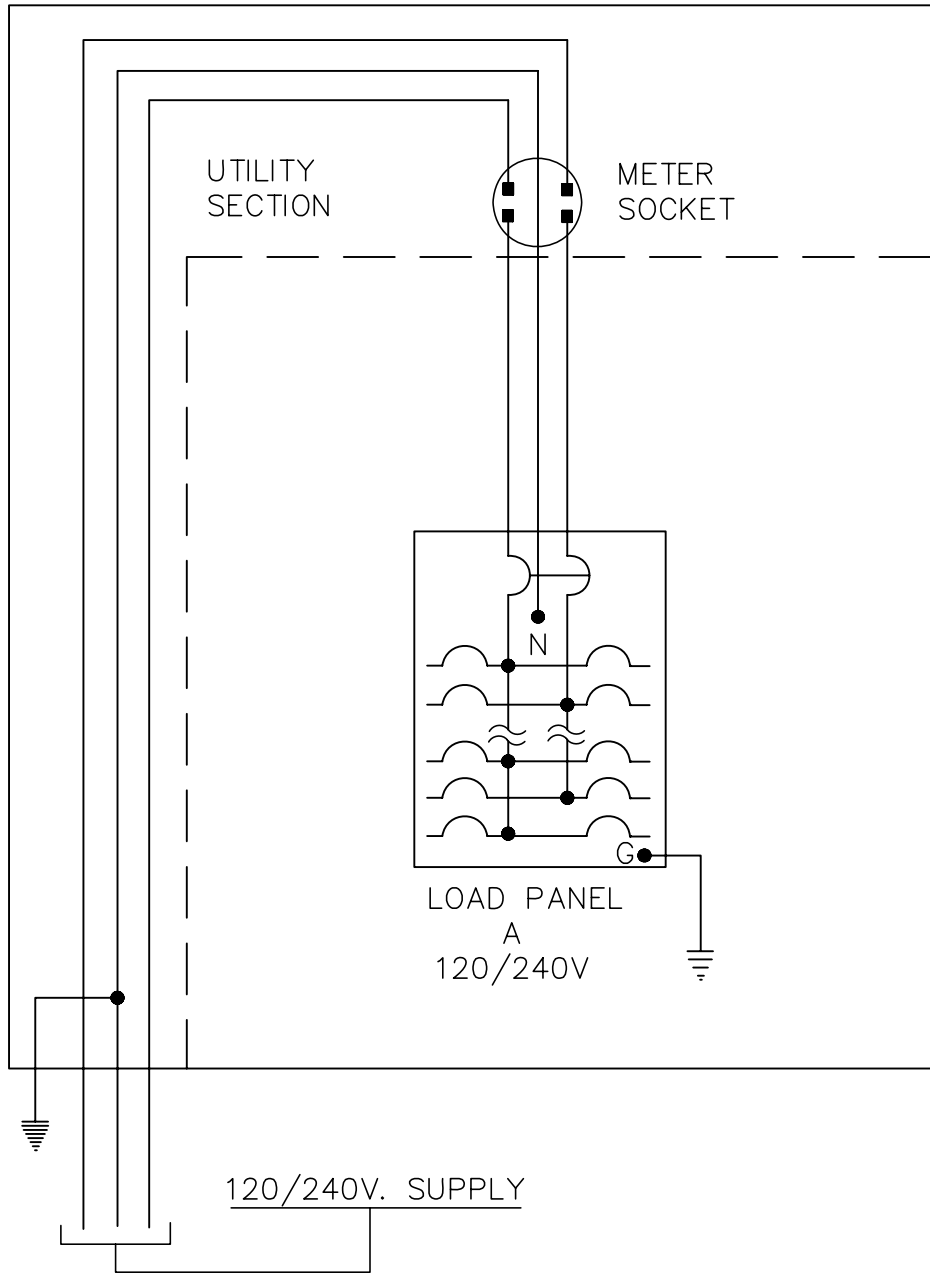

NOTE:
 1. SEE PANEL SCHEDULE, DETAIL 80-51

MUNICIPALITY



OF ANCHORAGE

SCALE:
 NTS

APPROVED:

REVISED:
 10/07

LOAD CENTER WIRING DIAGRAM "G"

SECTION #
 80.14

DETAIL #
 80-50

LOAD CENTER NO. _____ TYPE: _____

LOCATION: _____

PANEL A 120/240 VOLTS SINGLE PHASE 3 WIRE
 _____ AMPS MAIN LUGS, _____ AMPS INTERRUPT CAPACITY

CKT. DESCRIPTION	KVA	AMP			AMP	KVA	CKT. DESCRIPTION
			1	2			
			3	4			
			5	6			
			7	8			
			9	10			
			11	12			
			13	14			
			15	16			
			17	18			
			19	20			

MUNICIPALITY



OF ANCHORAGE

SCALE:
NTS

APPROVED:

REVISED:
10/07

PANEL SCHEDULE FOR WIRING DIAGRAM "G"

SECTION #
80.14

DETAIL #
80-51

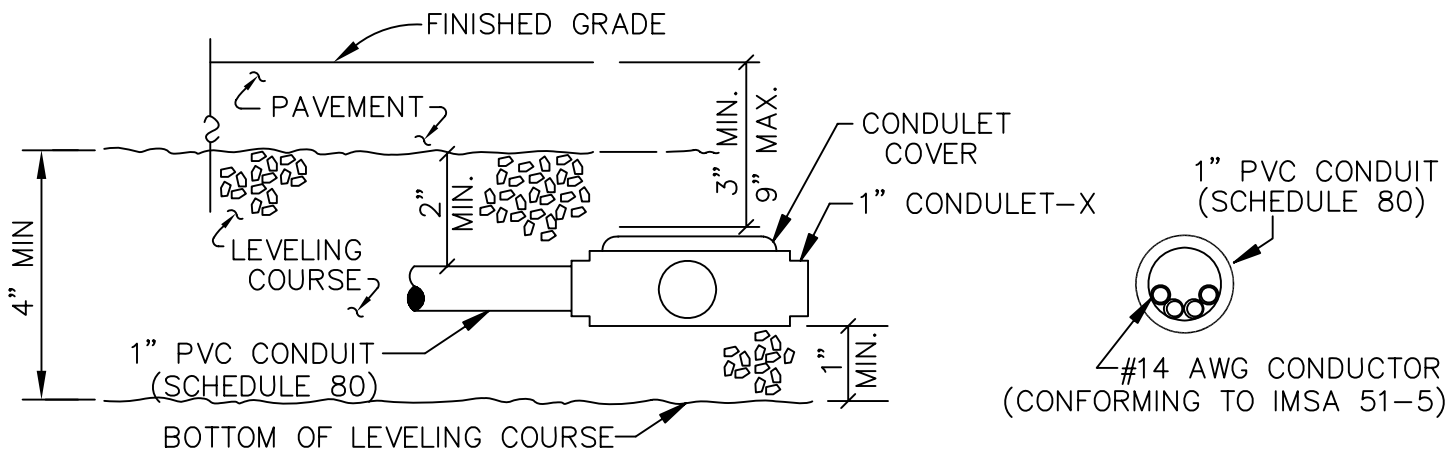
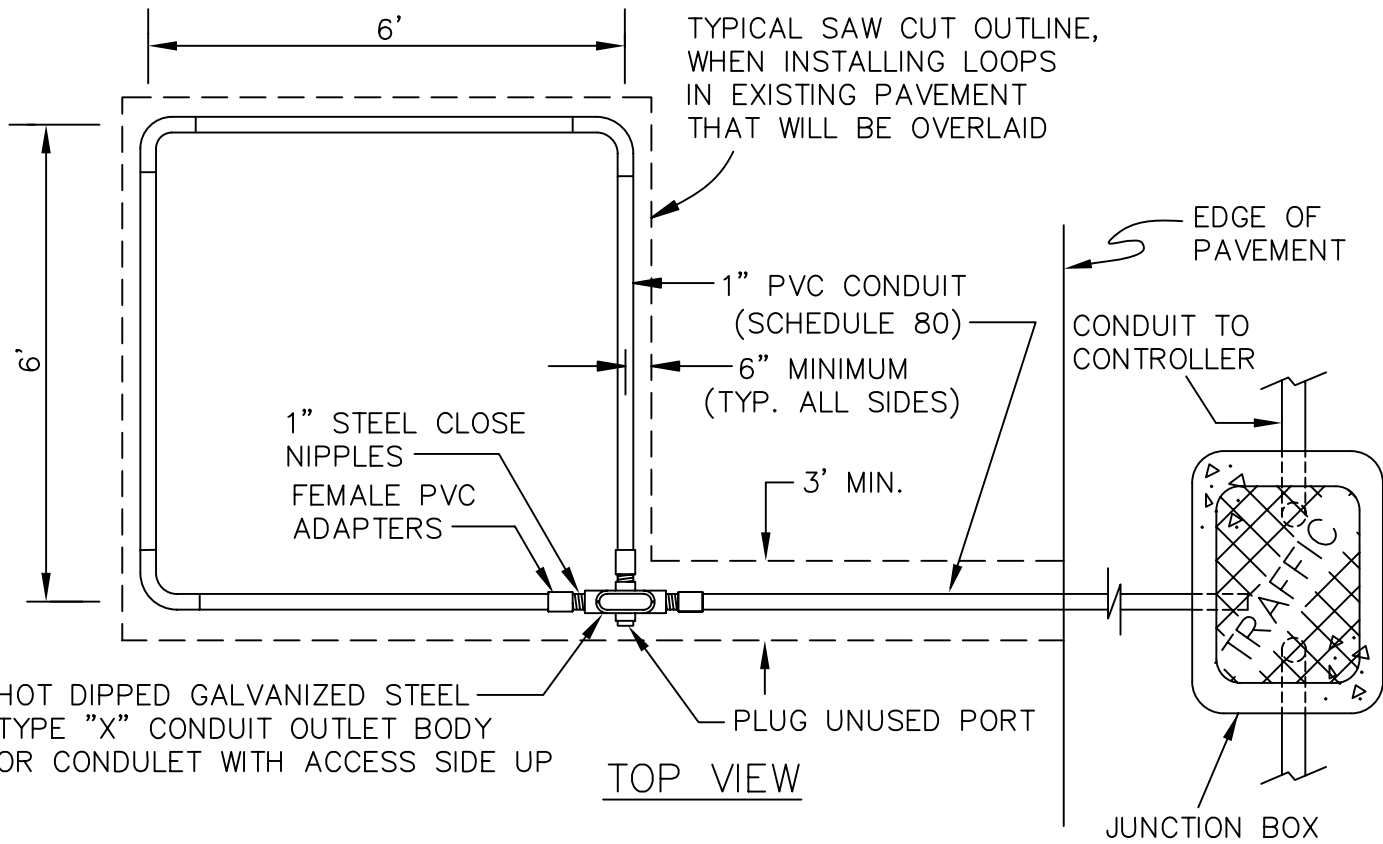

SIDE VIEW

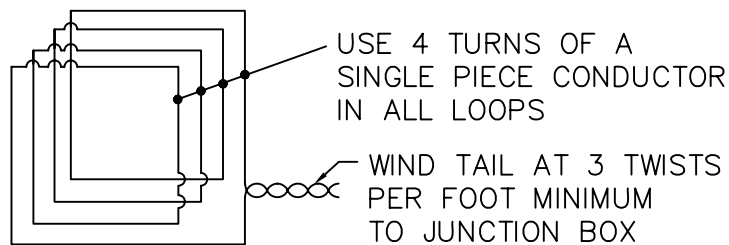

LOOP WIRING DETAIL

MUNICIPALITY



OF ANCHORAGE

SCALE:
NTS

APPROVED:

REVISED:
5/08

CONDUIT ENCASED LOOP DETECTOR

SECTION #
80.18

DETAIL #
80-52

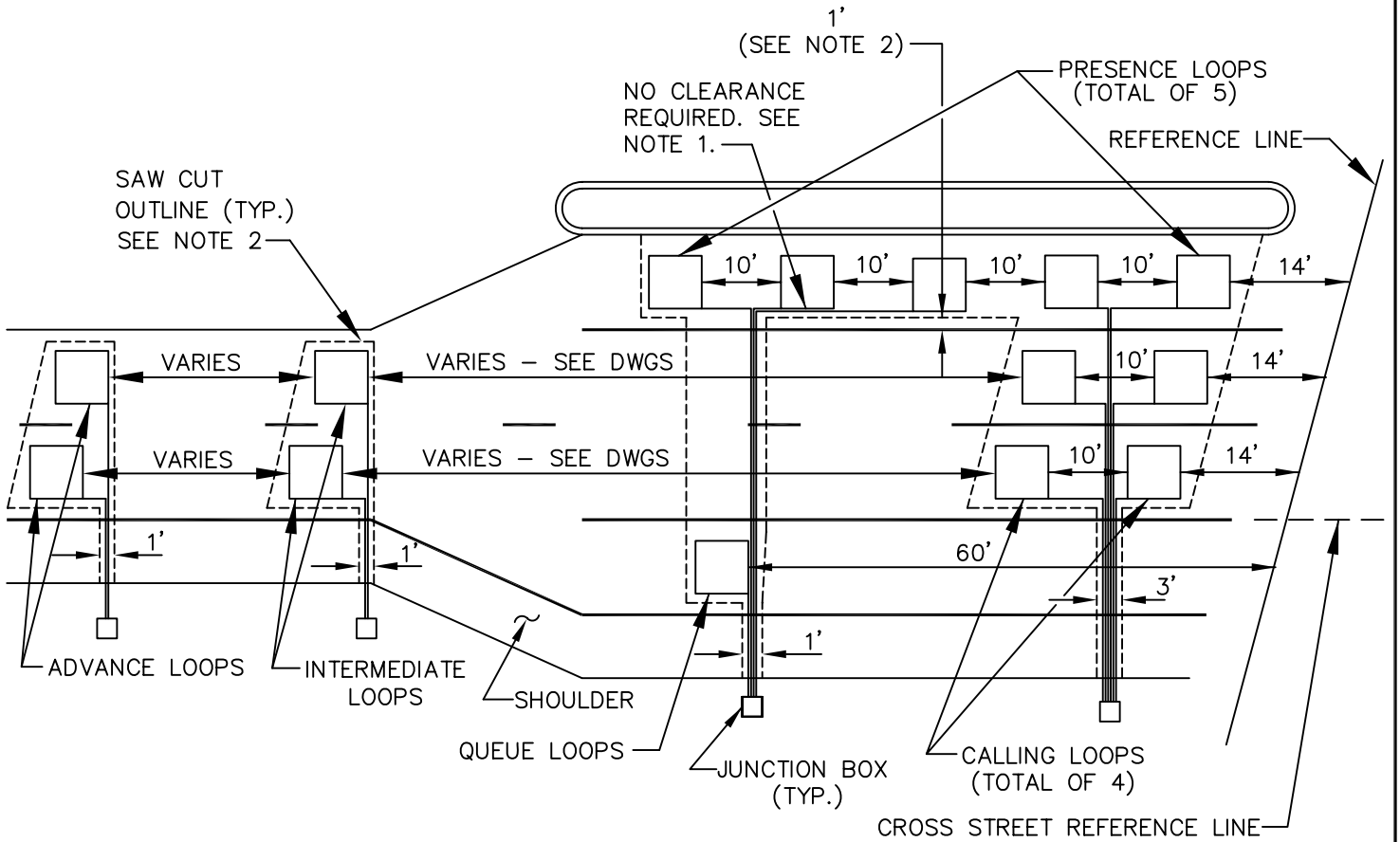

TYPICAL LOOP SETBACKS

MEASURE THE SETBACKS FROM THE REFERENCE LINE
ALONG THE CENTER OF EACH LANE

NOTES:

1. NO MINIMUM CLEARANCE IS REQUIRED BETWEEN A DETECTOR LOOP AND HOMERUN LOOP WIRES OR BETWEEN HOMERUN LOOP WIRES. HOMERUN LOOP WIRES SHALL NOT CROSS LOOP CONDUITS.
2. WHERE EXISTING PAVEMENT WILL NOT BE OVERLAID, ENCLOSE ALL LOOPS THAT ENTER A COMMON JUNCTION BOX WITHIN A TRAPEZOIDAL SAW CUT. CUT TO WITHIN 1 FOOT OF THE LANE AND EDGE LINES, PRESERVING THESE PAVEMENT MARKINGS; REMOVE THE ASPHALT TO THE LIP OF THE GUTTER WHEN THERE ARE NO EDGE LINES. CUT ACROSS LANE LINES WHEN LOOPS IN ADJACENT LANES ARE SIDE BY SIDE. CUT TRENCHES A MINIMUM OF 3 FEET WIDE WHEN INSTALLING LOOP TAILS ACROSS A LANE; CUT TRENCHES A MINIMUM 1 FOOT WIDE WHEN CROSSING A SHOULDER.

MUNICIPALITY



OF ANCHORAGE

SCALE:
NTS

APPROVED:

REVISED:
10/07

LOOP DETECTOR INSTALLATION DETAILS

SECTION #
80.18

DETAIL #
80-53

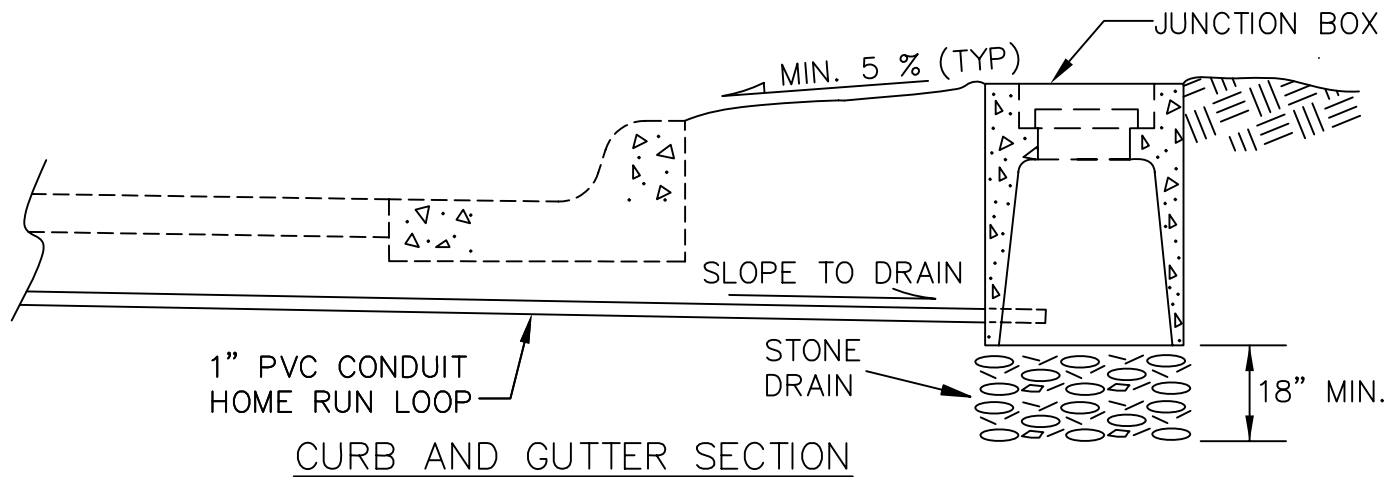
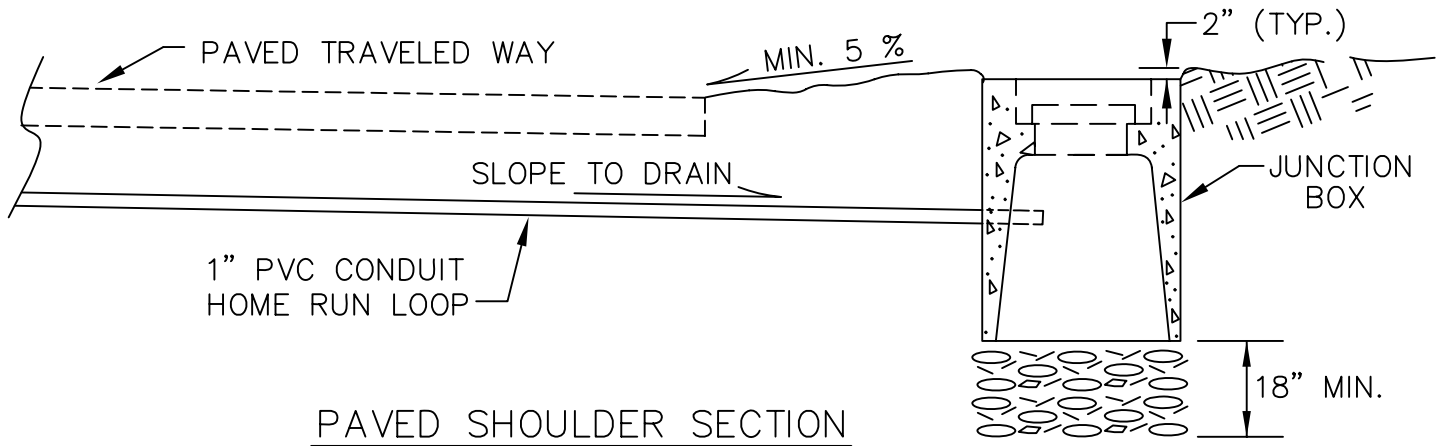
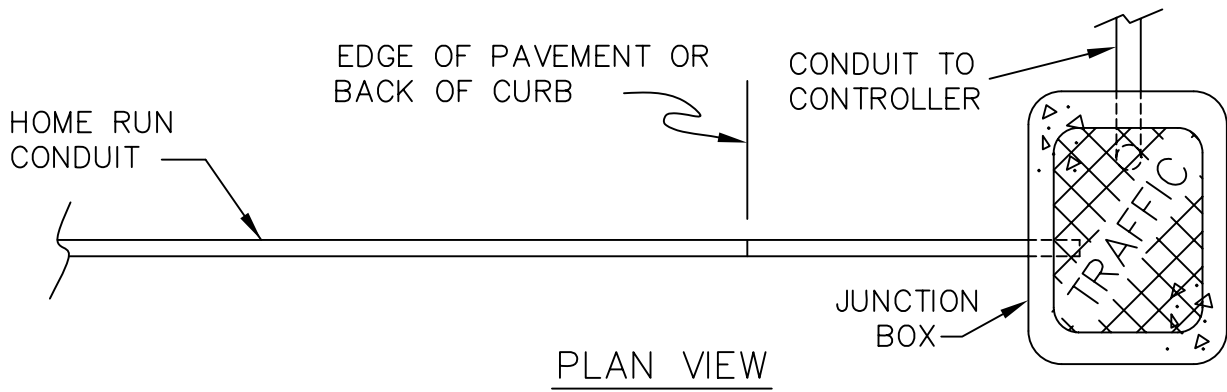

MUNICIPALITY



OF ANCHORAGE

SCALE:
NTS

APPROVED:

REVISED:
5/08

LOOP DETECTOR HOME RUN

SECTION #
80.18

DETAIL #
80-54

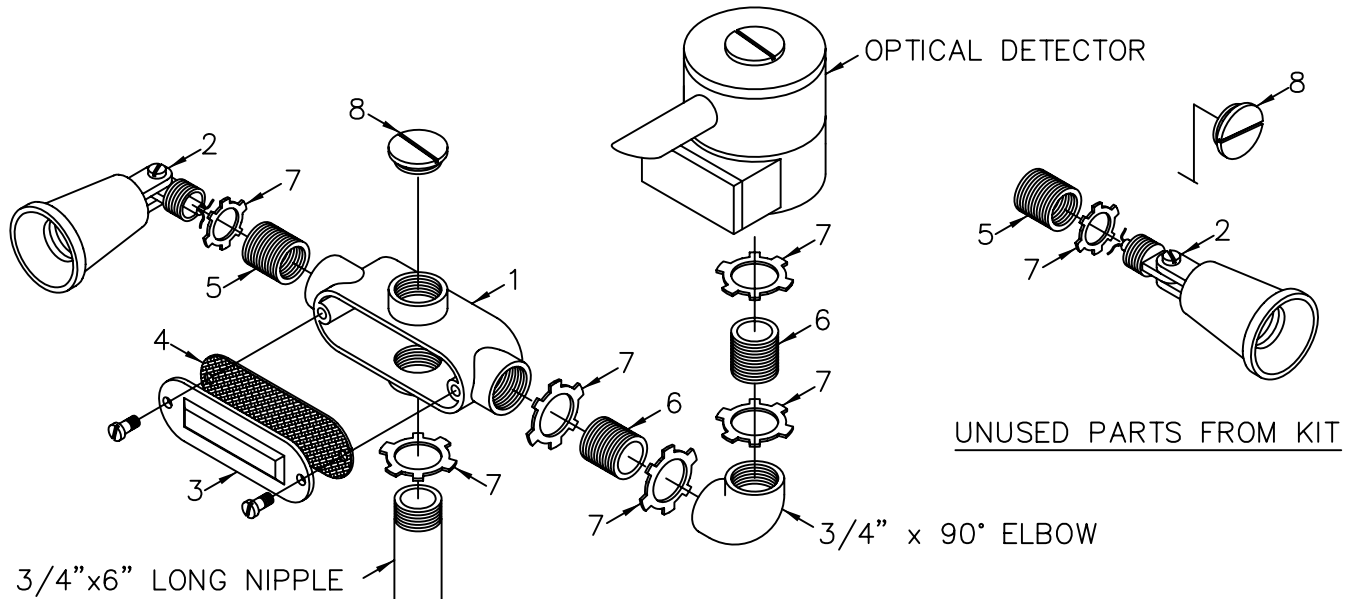

ASTRO-MINI-BRAC FROM
 PELCO PRODUCTS, INC.
 MODEL NO. AB-0155-L
 OR APPROVED EQUAL

ITEM. NO.	IDENTIFICATION	KIT QUANTITY	QUANTITY USED
1	"X" CONDULET BODY	1	1
2	PAR 38 LAMP HOLDER	2	1
3	CONDULET COVER	1	1
4	COVER GASKET	1	1
5	REDUCING BUSHING	2	1
6	3/4" CLOSE NIPPLE	2	2
7	3/4" LOCKNUT	3	6
8	3/4" HOLE PLUG	2	1

3M OPTICOM MODEL 575 CONFIRMATION LIGHT KIT

NOTES:

1. SEE THE SIGNAL PLANS FOR THE SIGNAL MAST ARMS SCHEDULED FOR OPTICOM DETECTOR INSTALLATION.
2. FOR EACH OPTICOM INSTALLATION, FURNISH THE FOLLOWING PARTS:
 - A. A 3M MODEL 711, 721, OR 722 OPTICOM DETECTOR AS SHOWN ON THE PLANS.
 - B. A 3M MODEL 575 CONFIRMATION LIGHT KIT, OR AN APPROVED EQUAL, THAT CONSISTS OF STEEL PARTS WITH A HOT DIP GALVANIZED FINISH.
 - C. A 3/4"x6" LONG PIPE NIPPLE AND A 3/4" 90° PIPE ELBOW. FURNISH BOTH PARTS WITH A HOT DIPPED GALVANIZED FINISH.
 - D. THREE ADDITIONAL 3/4" LOCKNUTS WITH ZINC PLATED FINISH.
 - E. AN ASTRO-MINI-BRAC, MODEL AB-0155-L, MANUFACTURED BY PELCO PRODUCTS, OR AN APPROVED EQUAL.
 - F. A 60 WATT, PAR 38, HALOGEN FLOOP LAMP RATED FOR 130 VOLT OPERATION, 1150 INITIAL LUMENS, AND A 3000 HOUR LAMP LIFE.
3. DRILL A 1" HOLE IN THE TOP DEAD CENTER OF THE MAST ARM AT THE OPTICOM DETECTORS PRE-APPROVED LATERAL LOCATION. ASSEMBLE THE PARTS AS SHOWN ON THIS SHEET.
4. BEFORE ATTACHING THE MODEL 138 DETECTOR CABLE TO THE OPTICOM DETECTOR, STRIP THE INSULATION FROM THE THREE INSULATED CONDUCTORS AT THE CONTROLLER CABINET AND ATTACH ALL FOUR CONDUCTORS TO GROUND.

MUNICIPALITY



OF ANCHORAGE

SCALE:
 NTS

APPROVED:

REVISED:
 10/07

OPTICOM DETECTOR INSTALLATION DETAILS

SECTION #
 80.18

DETAIL #
 80-55

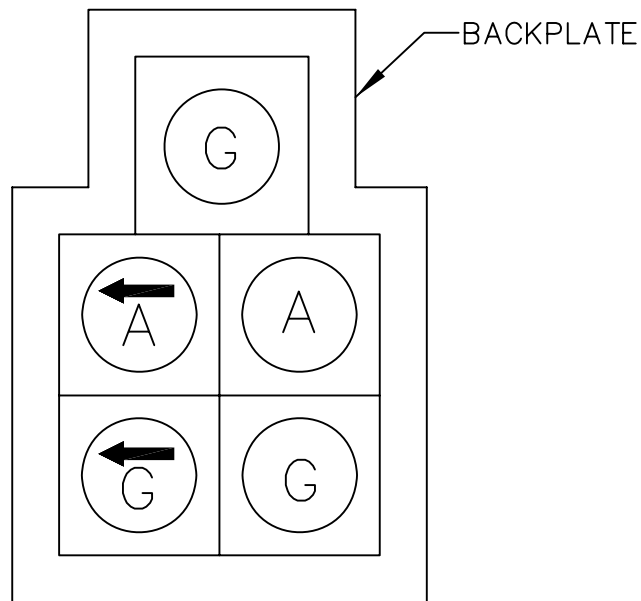

5-LENS HEAD

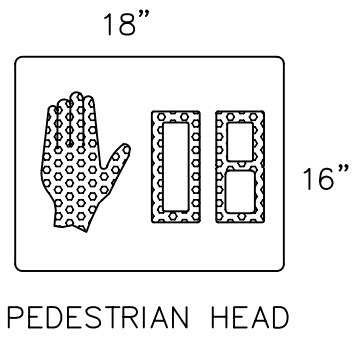

PEDESTRIAN HEAD

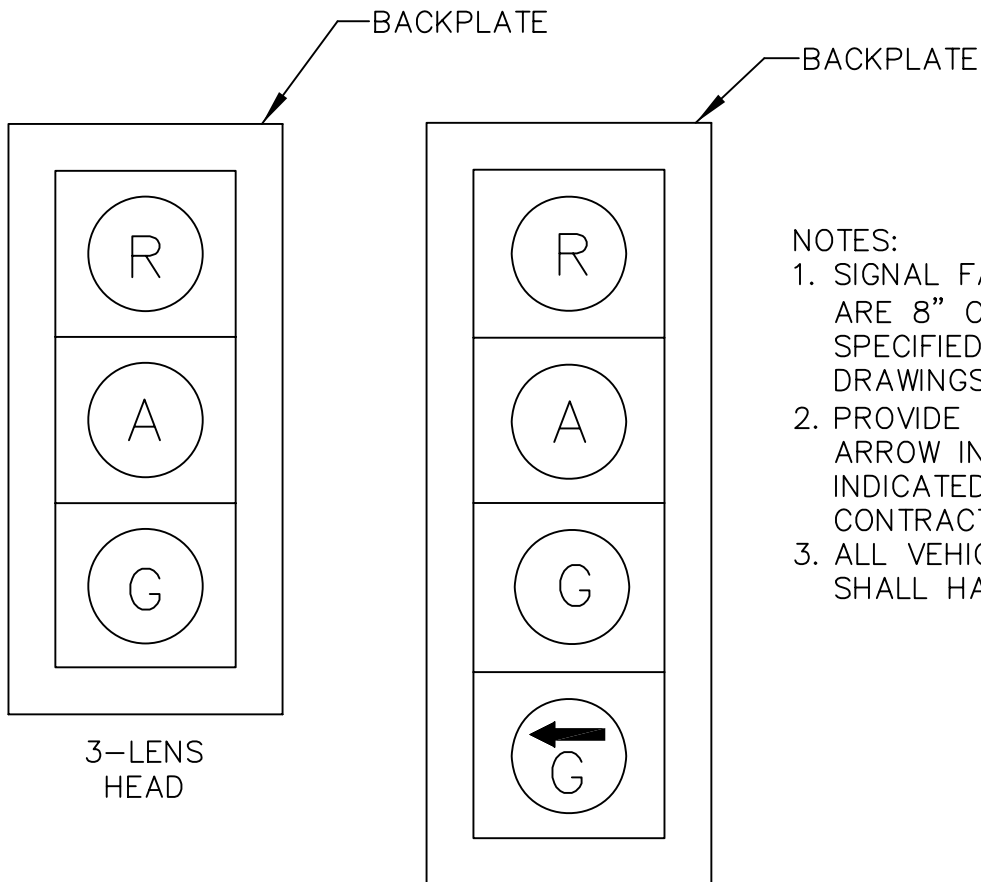

3-LENS HEAD

4-LENS HEAD

NOTES:

1. SIGNAL FACE DIMENSIONS ARE 8" OR 12" AS SPECIFIED IN THE DRAWINGS.
2. PROVIDE LEFT/RIGHT ARROW INDICATIONS, AS INDICATED IN THE CONTRACT DOCUMENTS.
3. ALL VEHICLE SIGNALS SHALL HAVE BACKPLATES.

MUNICIPALITY



OF ANCHORAGE

SCALE:
NTS

APPROVED:

REVISED:
6/08

SIGNAL HEADS

SECTION #

80.19 &
80.20

DETAIL #

80-56

SCHOOL FLASHER NOTES:

1. EACH FLASHER SHALL CONSIST OF FOUR 12-INCH SIGNAL FACES WITH YELLOW LENSES AND TUNNEL TYPE VISORS WITH OPEN SLOTS AT THE BOTTOM.
2. THE CONTRACTOR SHALL WIRE SIGNAL FACES 1 AND 2 ON FLASHER CIRCUIT 1 AND SIGNAL FACES 3 AND 4 ON FLASHER CIRCUIT 2.
3. BEACON FRAMEWORK

ITEM NO.	IDENTIFICATION	QTY.
A	1-1/2" 90° SERRATED ELBOW	2
B	1-1/2" TEE	1
C	1-1/2" x VARIES NIPPLE	1
D	1-1/2" x VARIES NIPPLE	2
E	1-1/2" LOCK NIPPLE	2

4. YELLOW SIGNAL FACE:
 12" (POSTED SPEEDS ≥ 40 MPH)
 8" (POSTED SPEEDS ≤ 30 MPH)
 FOR 35 mph SIGNAL FACE SIZE
 REQUIRES DISCRETION OF ENGINEER.

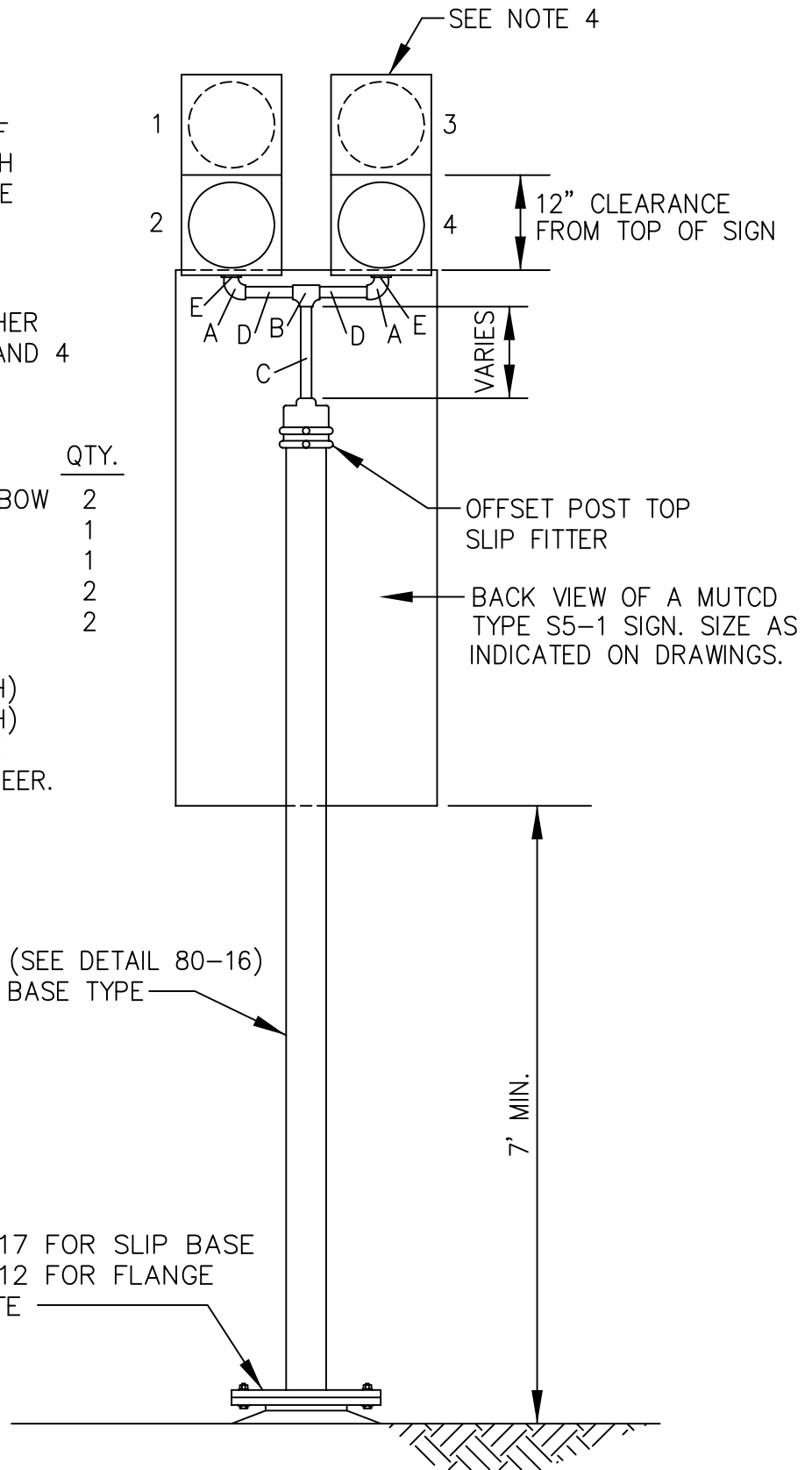

10' PEDESTAL POLE (SEE DETAIL 80-16)
 SEE DRAWINGS FOR BASE TYPE

SEE DETAIL 80-17 FOR SLIP BASE
 SEE DETAIL 80-12 FOR FLANGE
 TYPE BASE PLATE

7' MIN.

MUNICIPALITY

 OF ANCHORAGE

SCALE:
NTS
 APPROVED:
 REVISED:
10/07

SPEED LIMIT SIGN BEACON

SECTION #
80.22
 DETAIL #
80-57

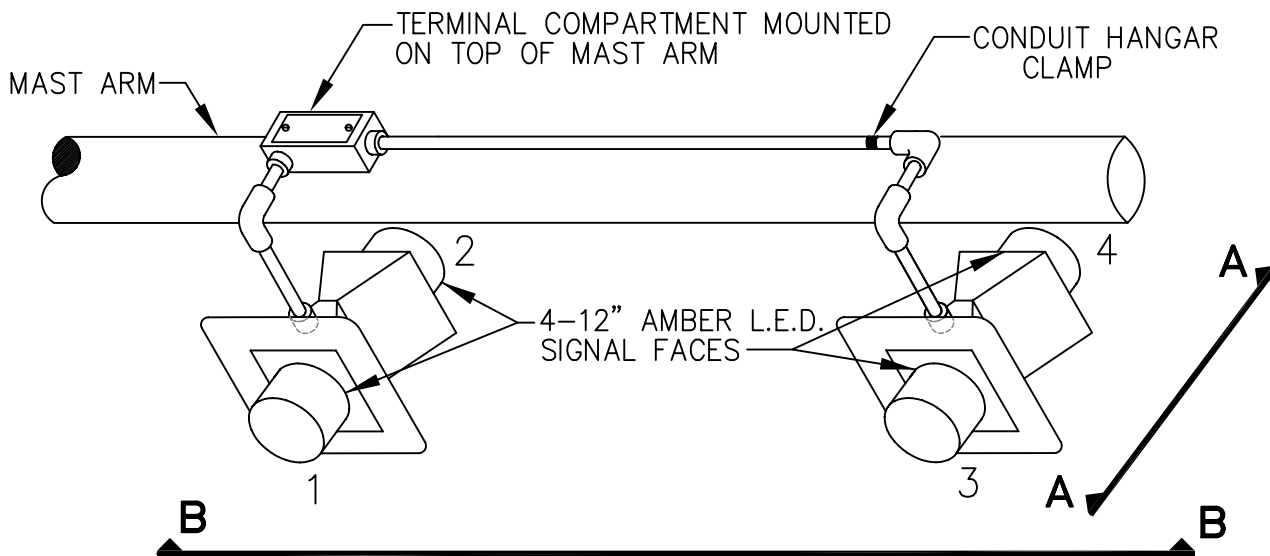

TWO NON-ILLUMINATED SIGNS, MOUNTED BACK TO BACK ON MAST ARM (SEE NOTE 2)

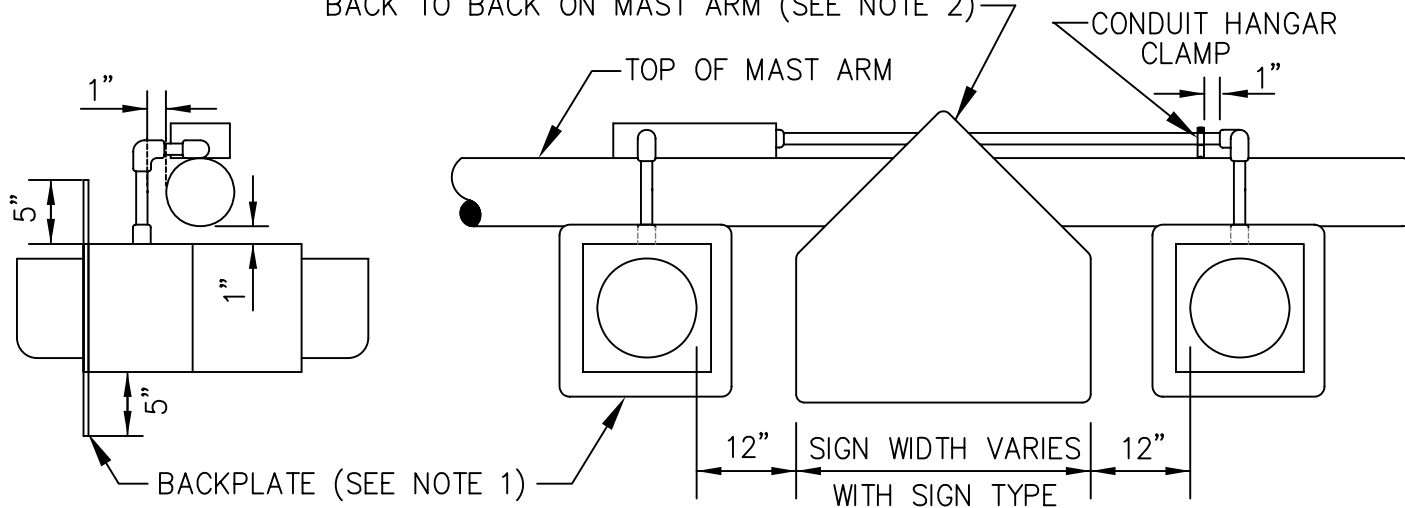

SECTION AA

SECTION BB

NOTES:

1. PROVIDE ALL SIGNAL HEADS WITH 5" BACKPLATES.
2. CONTACT MOA SIGN SHOP FOR MOUNTING METHOD.
3. PROVIDE MINIMUM VERTICAL CLEARANCE OF 18' FROM ROADWAY TO BOTTOM OF SIGNAL HEAD HOUSING OR BOTTOM OF SIGN.
4. WIRE SIGNAL FACES 1 AND 2 ON FLASHER CIRCUIT 1 AND SIGNAL FACES 3 AND 4 ON FLASHER CIRCUIT 2.
5. EACH UNIT SHALL CONSIST OF FOUR 12-INCH AMBER L.E.D. SIGNAL FACES AND TUNNEL TYPE VISORS WITH OPEN SLOTS AT THE BOTTOM.

MUNICIPALITY



OF ANCHORAGE

SCALE:
NTS

APPROVED:

REVISED:
5/08

**MAST ARM MOUNTED
SIGN BEACONS**

SECTION #
80.22

DETAIL #
80-58

12-INCH YELLOW SIGNAL FACE WITH
YELLOW LENS AND TUNNEL TYPE VISOR
WITH OPEN SLOT AT THE BOTTOM

1-1/2" x VARIES NIPPLE

1.0'
MIN.

VARIES

OFFSET POST TOP
SLIP FITTER

BACK VIEW OF A MUTCD
TYPE SIGN. SIZE AND TYPE
AS INDICATED ON DRAWINGS.

10' PEDESTAL POLE (SEE DETAIL 80-16)
SEE DRAWINGS FOR BASE TYPE

7' MIN.

SEE DETAIL 80-17 FOR SLIP BASE
SEE DETAIL 80-12 FOR FLANGE BASE

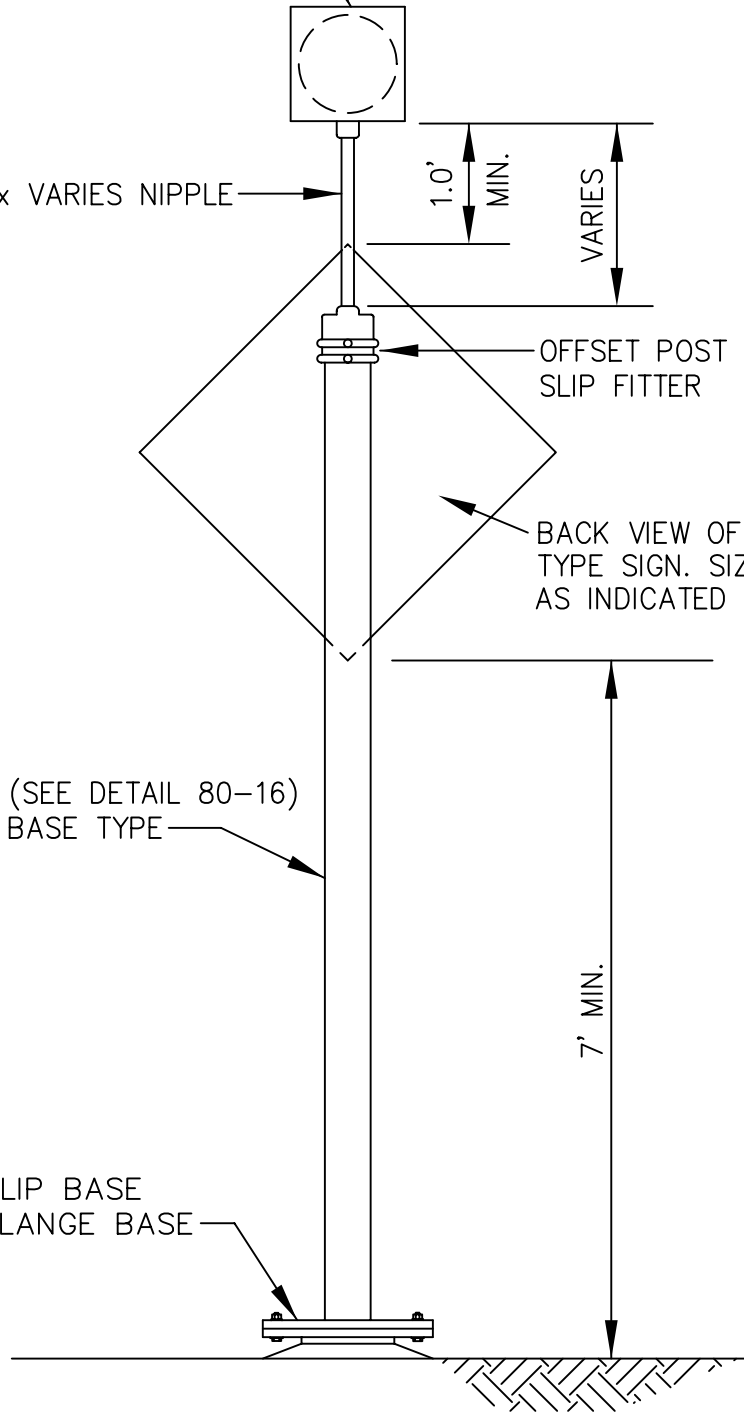

MUNICIPALITY



OF ANCHORAGE

SCALE:
NTS

APPROVED:

REVISED:
10/07

WARNING SIGN BEACON

SECTION #
80.22

DETAIL #
80-59

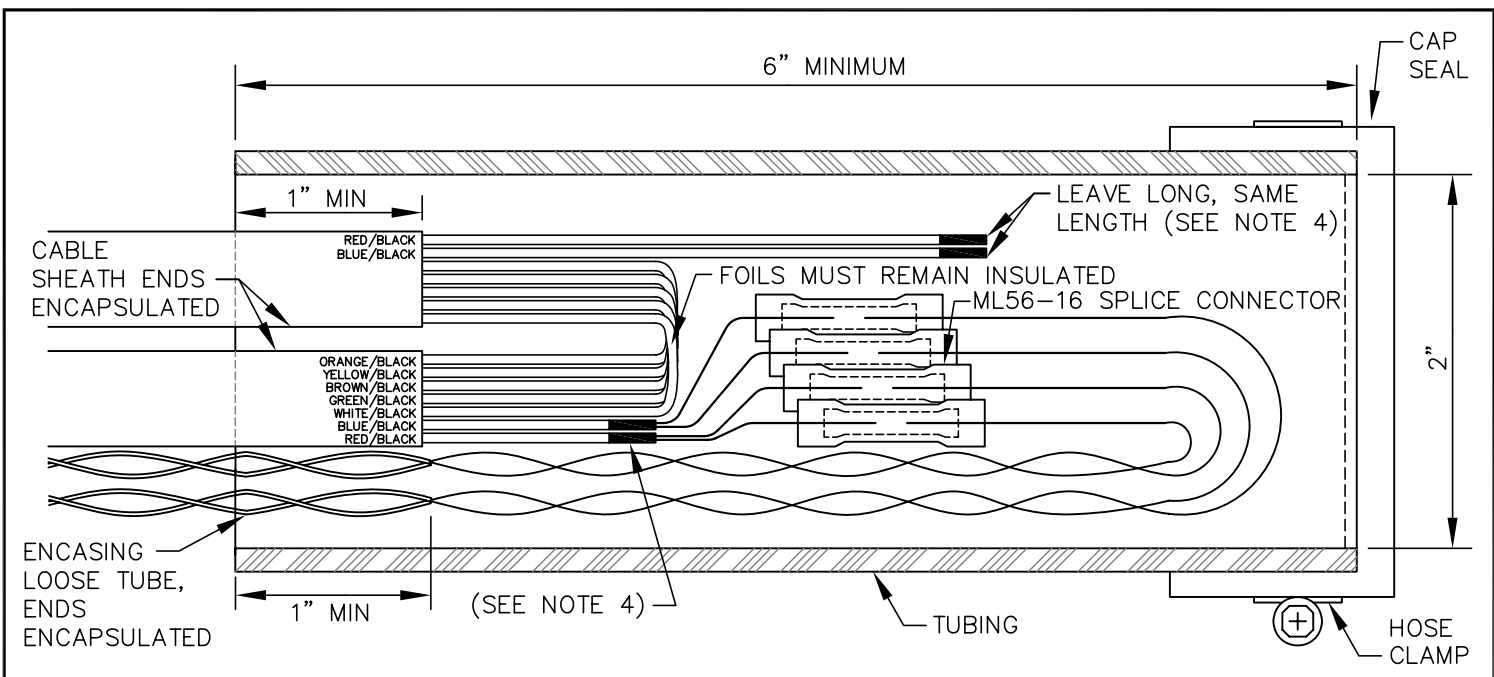

MATERIAL PROPERTIES	
LOOP LEAD-IN SPLICE	
TUBING	2" CORE FLOW
CAP SEAL	FERNCO QWIK CAP #QC-102
HOSE CLAMP	STAINLESS STEEL
SPLICE CONNECTOR	MULTILINK ML56-16 OR APPROVED EQUAL
COMPOUND	RE-ENTERABLE ENCAPSULATION

- NOTES:
1. FABRICATE LOOP LEAD-IN SPLICE IN THE FIELD AS SHOWN.
 2. CAP SEAL ONE END AND COMPLETELY FILL OPEN END WITH RE-ENTERABLE ENCAPSULATION COMPOUND TO EDGE OF CORE FLOW.
 3. LEAVE A MINIMUM OF 1/2" CLEARANCE BETWEEN THE ENCLOSURE AND THE SPLICE AT BOTH ENDS OF THE CORE FLOW.
 4. EXPOSED FOIL AND DRAIN WIRES, SEAL WITH HEAT SHRINK TUBING (TYP).
 5. SECURE CABLE/CONDUCTOR BUNDLE WITH NYLON CABLE TIES.

 <p>MUNICIPALITY OF ANCHORAGE</p>	<p>SCALE: NTS</p> <p>APPROVED:</p> <p>REVISED: 7/08</p>	<p>SPLICE DETAIL</p> <p>LOOP DETECTOR LEADS</p>	<p>SECTION # 80.48</p> <p>DETAIL # 80-60</p>

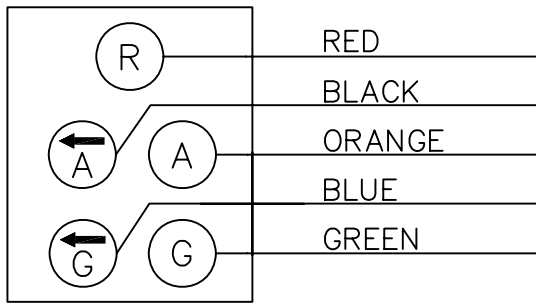

COMMON — WHITE
 SPARE — WHITE/BLACK

7-CONDUCTOR, 14 GAUGE
 CABLE (7C#14) WITH HEAD
 IDENTIFICATION BAND

5 SECTION HEAD

JUMPER GREEN
 ARROW TO
 GREEN BALL
 INSIDE SIGNAL
 HEAD

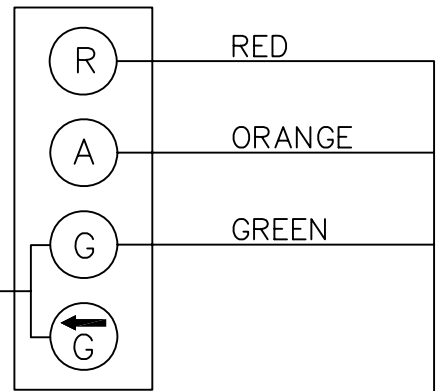

COMMON — WHITE
 SPARE — WHITE/BLACK
 SPARE — BLACK
 SPARE — BLUE

7-CONDUCTOR, 14 GAUGE
 CABLE (7C#14) WITH HEAD
 IDENTIFICATION BAND

4 SECTION HEAD

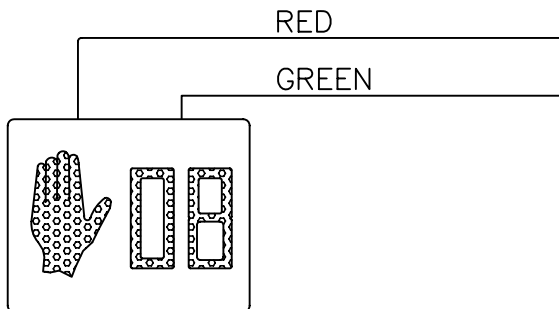

COMMON — WHITE
 COMMON — ORANGE
 SPARE — BLACK

5-CONDUCTOR, 14 GAUGE
 CABLE (5C#14) WITH HEAD
 IDENTIFICATION BAND

PEDESTRIAN HEAD

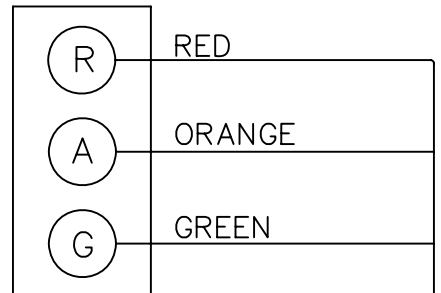

COMMON — WHITE
 COMMON — WHITE/BLACK
 SPARE — BLACK
 SPARE — BLUE

7-CONDUCTOR, 14 GAUGE
 CABLE (7C#14) WITH HEAD
 IDENTIFICATION BAND

3 SECTION HEAD

MUNICIPALITY



OF ANCHORAGE

SCALE:
 NTS

APPROVED:

REVISED:
 5/08

**SIGNAL HEAD
 WIRING DETAILS**

SECTION #
 80.19 &
 80.20
 DETAIL #
 80-61

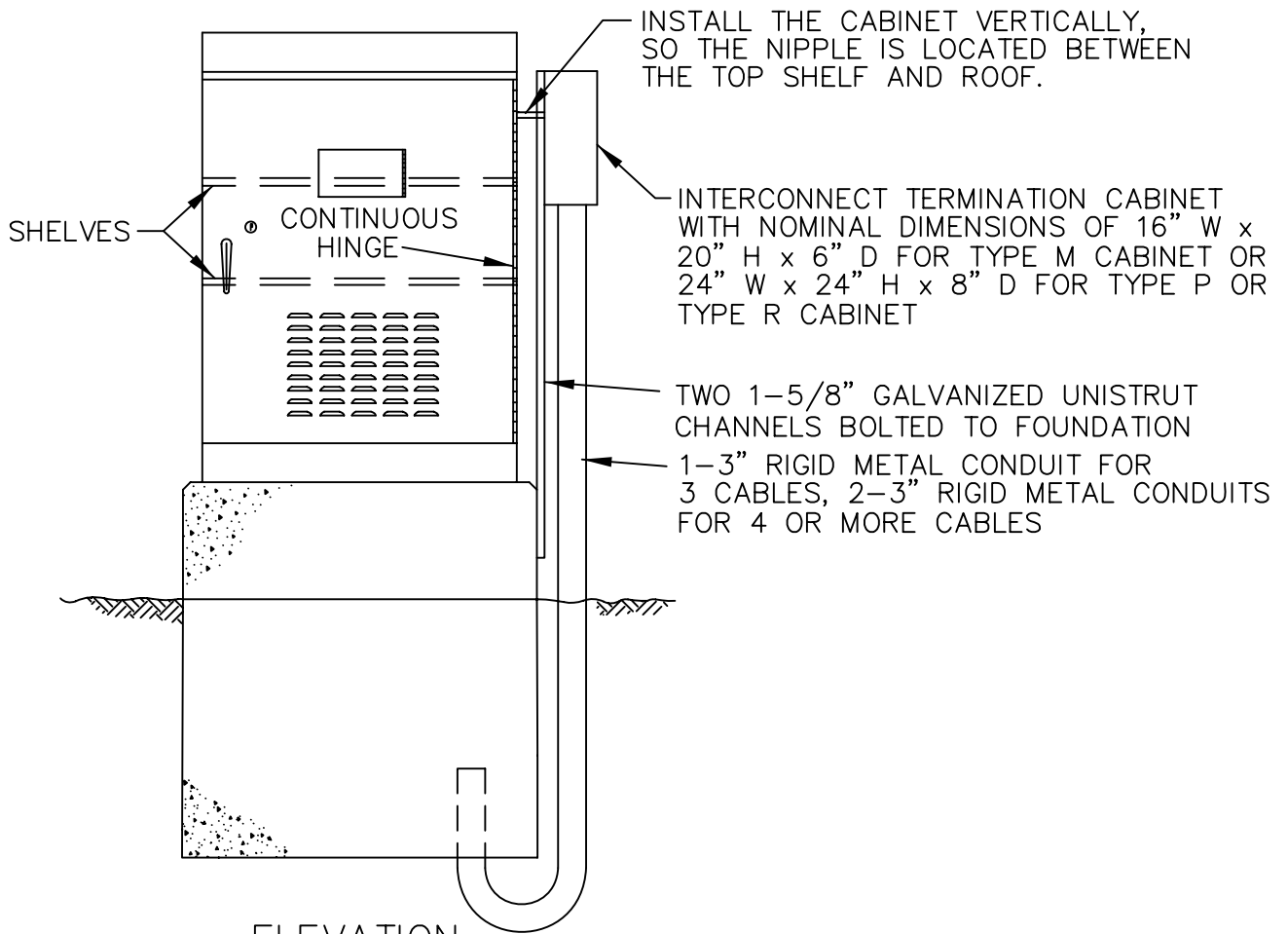

ELEVATION

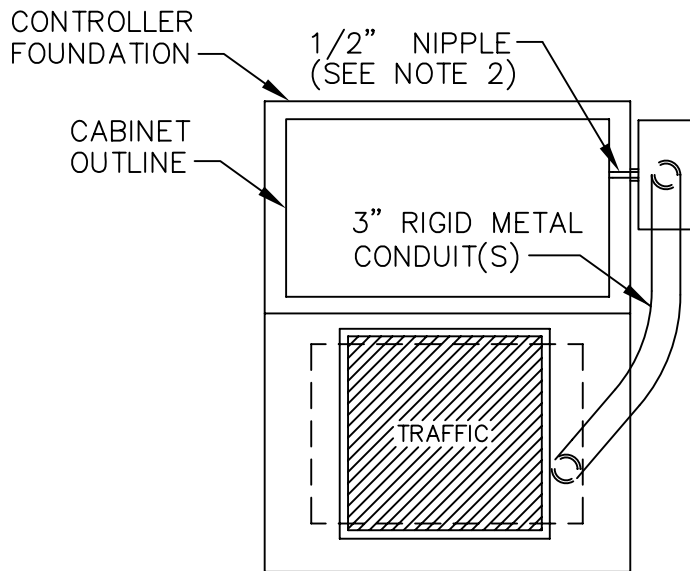

PLAN VIEW

NOTES:

1. INSTALL THE INTERCONNECT CABLE TERMINATION CABINET WHEN CALLED FOR IN THE DRAWINGS OR WHENEVER 3 OR MORE INTERCONNECT CABLES ARE TO BE TERMINATED.
2. COORDINATE INSTALLATION LOCATION OF 1/2" NIPPLE WITH MOA TRAFFIC SIGNAL ELECTRONICS, PRIOR TO DRILLING HOLE IN CABINETS.
3. SEE DRAWINGS TO DETERMINE WHETHER TO INSTALL ON RIGHT OR LEFT SIDE WALL OF CONTROLLER CABINET.
4. PROVIDE TWO TYPE 66B3-50 TERMINAL BLOCKS TO THE MOA FOR INSTALLATION BY OTHERS.

MUNICIPALITY



OF ANCHORAGE

SCALE:
NTS

APPROVED:

REVISED:
6/08

INTERCONNECT CABLE TERMINATION CABINET

SECTION #
80.26

DETAIL #
80-62

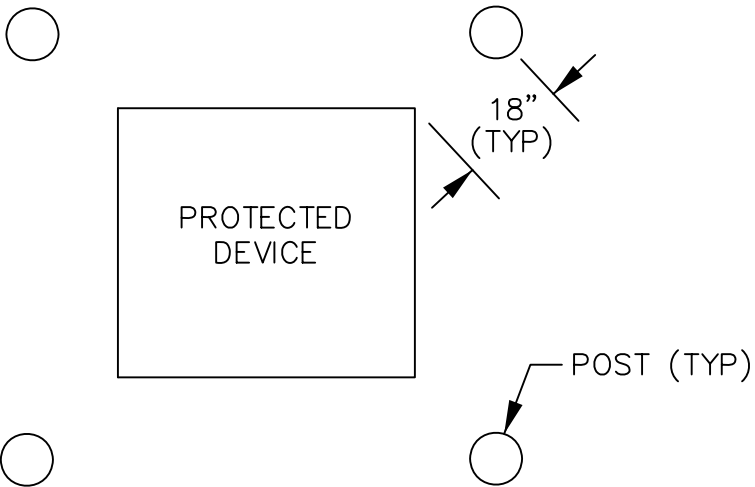

PLAN
LOCATE POSTS AS SHOWN

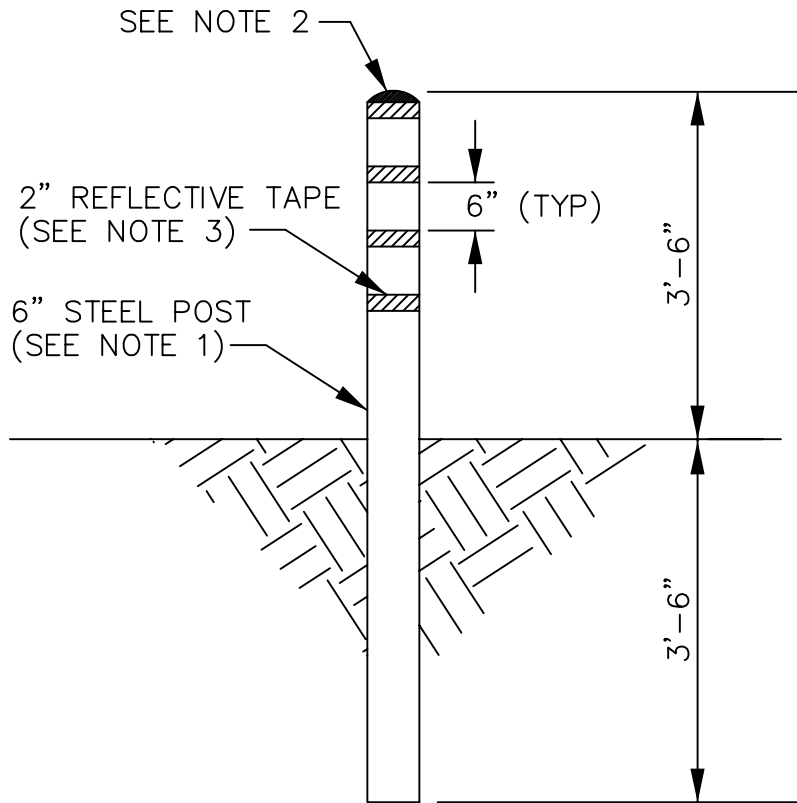

POST DETAIL

NOTES:

1. PROVIDE 6" STEEL, SCHEDULE #40 PIPE, FILLED WITH CONCRETE.
2. ROUND CONCRETE AT TOP OF POST SMOOTH AND PAINT YELLOW.
3. INSTALL 4-2" BANDS OF YELLOW REFLECTIVE TAPE AS SHOWN.
4. LOCATION AND QUANTITY OF POSTS AS INDICATED ON DRAWINGS.

MUNICIPALITY



OF ANCHORAGE

SCALE:
NTS

APPROVED:

REVISED:
10/07

**PROTECTIVE POST
ASSEMBLY**

SECTION #
80.28

DETAIL #
80-63

