

CHAPTER 21.09: GIRDWOOD

21.09.010	PURPOSE.....	9-3
21.09.020	APPLICATION OF CHAPTER 21.09.....	9-3
A.	Applicability	9-3
B.	Relationship to Other Title 21 Provisions.....	9-3
C.	Girdwood Defined	9-3
D.	Nonconformity Determinations.....	9-4
E.	Chapter 21.09 Area Map.....	9-5
21.09.030	ADMINISTRATION AND REVIEW PROCEDURES.....	9-6
A.	Title 21 Administrative Provisions and Procedures Apply	9-6
B.	Pre-Application Meetings	9-6
C.	Use Area and Use District Boundaries to be Established During the Master Planning Process	9-6
D.	Minor Modifications for Site Constraints	9-7
E.	Area Master Planning.....	9-8
F.	Development Master Planning.....	9-12
21.09.040	ZONING DISTRICTS	9-15
A.	Zoning Districts Established.....	9-15
B.	Residential Districts.....	9-16
C.	Commercial Districts	9-19
D.	Industrial Districts	9-25
E.	Resort Districts	9-26
F.	Other Districts	9-27
21.09.050	USE REGULATIONS.....	9-35
A.	Table of Allowed Uses	9-35
B.	Use-Specific Definitions and Standards.....	9-46
C.	Accessory Uses	9-52
D.	Definitions	9-57
21.09.060	DIMENSIONAL STANDARDS	9-59
A.	Applicability	9-59
B.	Dimensional Standards Tables	9-59
21.09.070	SITE DEVELOPMENT AND DESIGN STANDARDS	9-67
A.	Purpose and General Goals	9-67
B.	Applicability	9-67
C.	Hazard Areas	9-67
D.	Grading and Drainage.....	9-67
E.	Landscaping, Vegetation, and Tree Retention	9-68
F.	Transportation and Connectivity	9-70
G.	Lighting.....	9-72
H.	Pedestrian Circulation	9-74
I.	Fences and Walls.....	9-74
J.	Utilities and Utility Equipment Standards	9-74
K.	Snow Management	9-75
L.	Off-Street Parking Standards.....	9-76
M.	Signage	9-77
N.	Driveway Standards.....	9-81
O.	Trash Management in Multi-Family, Commercial, Industrial, and Resort Districts	9-84

21.09.080	BUILDING DESIGN STANDARDS	9-84
A.	Purpose and General Goals	9-84
B.	Alternative Equivalent Compliance	9-84
C.	Single-Family (Detached) Building Design Standards.....	9-84
D.	Two-Family and Attached Single-Family Building Design Standards.....	9-85
E.	Multiple-Family and Townhouse Building Design Standards	9-85
F.	Commercial, Resort and Public/ Institutional Building Design Standards	9-88
G.	Industrial Building Design Standards.....	9-94
21.09.090	ZONING MAPS	9-94
A.	Girdwood Zoning Districts	9-94
B.	Girdwood Zoning Districts (Lower Valley Enlargement)	9-94
C.	Single-Family/Two-Family Residential Districts	9-94
D.	Multiple-Family Residential Districts	9-94
E.	Commercial Districts	9-94
F.	Industrial Districts.....	9-94
G.	Resort Districts.....	9-94
H.	Girdwood Airport, GIP, and GIP-p Districts	9-94
I.	Girdwood Commercial Recreation Districts 1,2 and 3.....	9-94
J.	Girdwood Development Reserve and Recreation Reserve Districts	9-94
K.	Open Space and Girdwood Watershed Districts	9-94

CHAPTER 21.09: GIRDWOOD LAND USE REGULATIONS

21.09.010 PURPOSE

The purposes of this chapter 21.09 are to provide standards and regulations to implement the comprehensive plan elements for Girdwood, preserve and enhance the distinctive mountain-resort character and natural environment of the Girdwood area, and avoid overlap with standards and regulations applicable in other districts of the Municipality.

(AO 2012-124(S), 2-26-13)

21.09.020 APPLICATION OF CHAPTER 21.09

A. Applicability

These regulations and standards shall apply only to the Girdwood area of the Municipality as further delineated below.

B. Relationship to Other Title 21 Provisions

1. To the extent any provision in this chapter conflicts with other provisions of title 21, the provisions of this chapter shall govern. If certain provisions overlap but are not in conflict, then the provisions of this chapter shall be considered to supplement title 21 requirements and are additional requirements.
2. When any section of title 21, with the exception of chapter 21.08, references class A and class B districts, any lot in Girdwood that is less than 40,000 square feet shall be considered a class A district, and any lot in Girdwood that is 40,000 square feet or greater shall be considered a class B district.

C. Girdwood Defined

This chapter applies to, and the term Girdwood in this chapter refers to, the land in Girdwood Valley shown on the Girdwood map in section 21.09.020D. and having the following real property description:

Those lands lying within the boundary of the Municipality of Anchorage, within the Anchorage Recording District, Third Judicial District, State of Alaska; including all private, municipal and state land and those lands under state selection in Chugach National Forest; more particularly described as follows:

1. **Township 10 North, Range 2 East, Seward Meridian, Alaska**
 - a. All of Sections 1, 2, 3, 4, 9, 10, 11, 12, 15, 16, 17, 19, 20, 21, 28, 29, 30, 32, 33
 - b. All of Sections 5, 7, 8, 18, excluding Chugach State Park
 - c. W2 of Section 14; and
 - d. N2N2 of Section 22
2. **Township 10 North, Range 3 East, Seward Meridian, Alaska**
 - a. All of Section 5, excluding the NE4 within Chugach National Forest
 - b. All of Section 6
 - c. All of Section 7, excluding the SE4 within Chugach National Forest
 - d. NW4 of Section 8
 - e. N2NW4 of Section 18

3. **Township 11 North, Range 3 East, Seward Meridian, Alaska**
 - a. All of Sections 29, 31
 - b. SE4 of Sections 20, 30
 - c. W2SW4 of Section 21
 - d. W2W2 of Section 28
 - e. NE4 of Section 32
 - f. NW4NW4 of Section 33
4. **Township 11 North, Range 2 East, Seward Meridian, Alaska**
 - a. All of Sections 20, 21, 22, 27, 28, 29, 32, 33, 34
 - b. E2E2 of Sections 19, 30, 31
 - c. W2W2 of Sections 23, 26
 - d. All of Section 35, excluding the N2NE4 and NE4NW4 within Chugach National Forest
 - e. All of Section 36, excluding the NW4NW4 within Chugach National Forest
 - f. Excluding all lands within the boundaries of Chugach State Park and non-state-selected lands with Chugach National Forest

D. Nonconformity Determinations

Nonconformity determination fees relating to property in Girdwood that has become nonconforming with the adoption of this chapter shall be waived for one year after January 1, 2006.

E. Chapter 21.09 Area Map

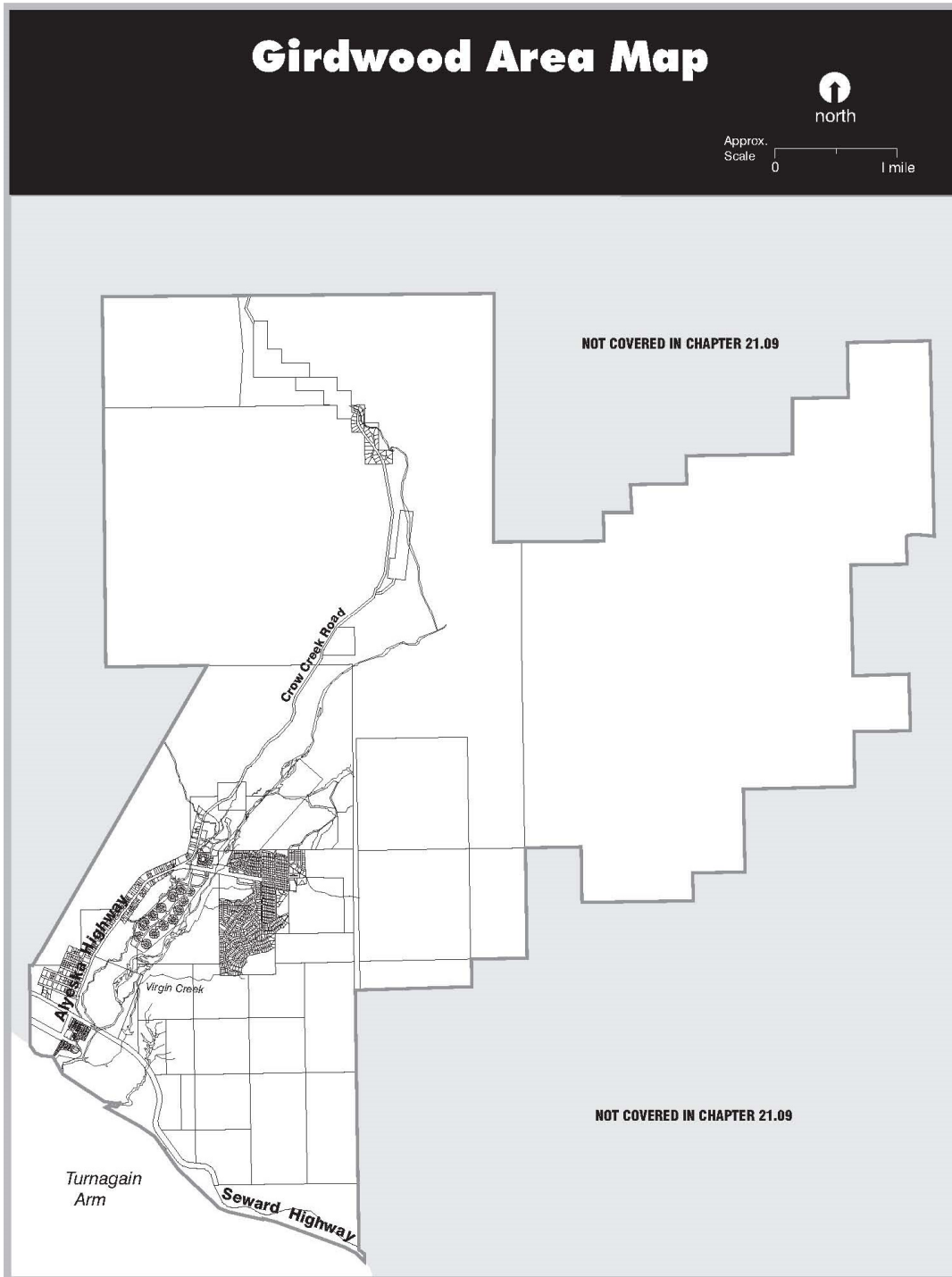

(AO 2012-124(S), 2-26-13)

21.09.030 ADMINISTRATION AND REVIEW PROCEDURES

A. Title 21 Administrative Provisions and Procedures Apply

Except as provided specifically in this chapter, all development in Girdwood shall be subject to and reviewed pursuant to the generally applicable administrative and review procedures set forth in chapters 21.02, *Boards, Commissions, and Municipal Administration*, and 21.03, *Review and Approval Procedures*.

B. Pre-Application Meetings

A pre-application meeting with the director is required for all applications for rezonings, subdivisions, conditional uses, and master plans, unless waived by the director.

C. Use Area and Use District Boundaries to be Established During the Master Planning Process

Where specific boundary lines need to be established between lands in different ownerships, or lands within the same ownership with different land uses as defined by a master plan, the *Girdwood Area Plan*, or the table of allowed uses in this chapter, and no adequate boundaries exist to serve this purpose, the boundaries shall be defined as outlined below. These steps make explicit the intent of a boundary line (for example, to correspond with a stream setback). By clearly defining the intent of these boundaries, the lines may be correctly located during subsequent field surveys. These steps are particularly important in the delineation of areas to remain in the open space district.

1. The master plan process is used to identify the basis for boundaries separating land uses and lands in different ownerships (e.g., boundary between lands to remain in public ownership and lands sold for development). This includes both defining boundaries within the overall master plan area, and refining the external boundaries of the master plan area, particularly important where external boundaries are based on generalized environmental data associated with the *Girdwood Area Plan*.
2. Boundaries shall be based on at least one of the references listed below, suitable for final determination of the boundary at such time as subdivision and the associated survey occurs.
 - a. A surveyed or otherwise readily observed geographic reference point or line (such as a public street, property line or boundary, centerline of a stream channel, etc.);
 - b. A describable environmental condition (such as change in vegetative cover type or slope); or
 - c. A land use objective, including those adopted in the *Girdwood Area Plan* (such as the boundary between an area of low and moderate density residential use, controlled in large part by the total number of residential uses allowed within the master plan area).
3. The master plan process is an appropriate tool to refine the external boundaries of land use districts set by the *Girdwood Area Plan*. In making these refinements, the total amount of land intended for the Open Space district shall not be less than the *Girdwood Area Plan* open space acreage identified within the particular area covered by a specific, single master plan. However the boundaries with the adjoining open space may be shifted to create a more efficient and logical land use pattern.

This tool does not preclude requesting a zoning map amendment for a change of use (see section 21.03.160) over a larger area than may be accommodated through the boundary refinement process.

4. The written and mapped description of boundaries of all applicable land use districts shall be determined by master plan analyses and shall be included in the materials submitted as part of the master plan. These boundaries shall not be modified substantially at the time of subsequent development review without a show of cause by the applicant, and following review and approval by the approving agency.

D. Minor Modifications for Site Constraints

It is the intent of this subsection to allow special consideration to those lots adversely affected by their existing conditions and/or the setbacks set forth in this subsection. The director is authorized to consider and grant the following minor modifications:

1. Physical Features

If, on lots $\leq 15,000$ square feet in the residential, commercial, and resort districts, or on lots less than 80 feet wide in residential districts, site constraints, such as stands of mature trees, rock outcroppings, slopes over 30 percent, wetlands, highway setbacks, or other permanent obstacles, are present within the building envelope defined by the setbacks, the building envelope may be shifted on the lot by reducing the rear setback to a minimum of 10 feet, and the side setback to a minimum of five feet on one side, but the total area of the building envelope shall remain the same. However, the front setback shall not be reduced.

2. Lot Shape, Residential Districts

For wedge-shaped lots $\leq 15,000$ square feet, if the difference in lot width is greater than 20 feet from front to back, the 10 foot side setback in section 21.09.060A.1. shall apply in the wider half of the lot. In the narrower half of the lot, the side setback shall be five feet. For purposes of this subsection, the boundary between the two halves of the lot shall be determined by locating a line midway between the front and rear lot boundaries. The five foot setback in the front half of the lot shall transition into the 10 foot setback in the rear half of the lot as shown in the figure below. This provision supersedes the side and rear setback flexibility in note 2 of table 21.09-5.

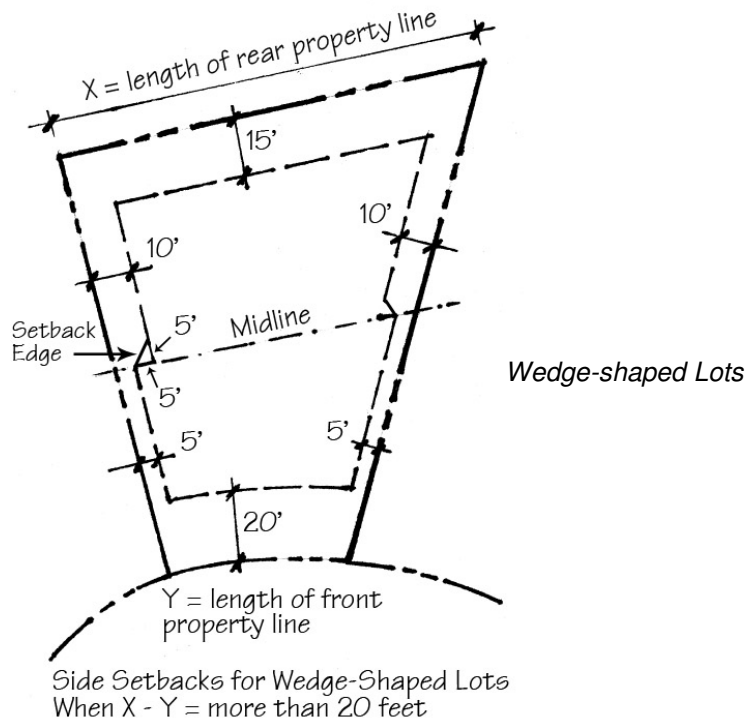

3. Narrow Lots, Commercial Districts

On narrow lots, where side setbacks result in a building envelope width of less than 25 feet, the building envelope may be expanded into one or more side setback(s), as needed to provide a 25 foot wide building envelope, but a side setback(s) shall not be reduced to less than five feet, except as provided in the dimensional standards in table 21.09-6, nor shall the adjusted building envelope width be greater than 25 feet.

4. Corner Lots, Commercial Districts

On corner lots where the secondary front setback reduces the building envelope to less than 25 feet in width, the secondary front setback may be reduced to no less than equal to the side yard setback requirement for the district, as needed to increase the building envelope to no more than 25 feet wide.

E. Area Master Planning

1. Purpose

An area master plan is intended to facilitate the planned development of large tracts of land under unified ownership or control, prior to subdivision or development of entire tracts or parcels within large tracts, in order to provide for land use compatibility and development responding to site-specific environmental constraints and opportunities. The area master plan shall establish the general arrangement of land uses, circulation and infrastructure systems for the identified development areas.

2. Applicability

a. *Mandatory: Girdwood*

An area master plan review is required prior to development in any of the following Girdwood zoning districts: gR-3, gC-5, GRST-2, GCR-1, GCR-2, GCR-3, GDR, GRR.

b. *Optional*

In addition to the criteria listed above, any other area in joint or single ownership may opt to use the area master plan process on a voluntary basis.

3. Procedures

a. *Pre-Application Conference*

Before filing an application, an applicant shall request a pre-application conference with the director.

b. *Community Meeting*

A community meeting may be required.

c. *Initiation*

An application for approval of an area master plan shall be initiated by the owner of the property.

d. *Application Filing*

Applications for approval of an area master plan shall be submitted to the director and shall contain all information and supporting materials specified in subsection e., below.

e. *Submittal Requirements*

Submittal requirements are set out below, and shall be in either narrative or illustrative form. The director may waive submittal requirements not relevant to the proposed area master plan. The planning and zoning commission and/or the director may require the submission of other information as may be necessary for the informed exercise of judgment under the criteria for the review of the plan, as set out in subsection 4., below. Where the director determines, as a result of the pre-application conference, that additional information will be needed to evaluate

the proposed area master plan, this shall be indicated in writing to the applicant following the pre-application conference, along with the record of pre-application conference discussion required by subsection 21.03.020B.4.c.

- i. The legal description, boundaries, and acreage of the petition area, and an explanation of boundary delineation, pursuant to subsection 21.09.030C., if applicable;
- ii. The present land use classification of the petition area and abutting property;
- iii. The current use, if any, of the petition area and abutting property, including roads, utilities, drainage systems, trails, parks, parking lots, and any structures;
- iv. The general topography of the petition area (contours lines shall be shown at intervals of 10 feet or less), including any unique natural or historical features. Mapping shall be at a scale of one inch equals 200 feet, or less;
- v. A general description of the existing vegetation, soils, drainage patterns, and habitat in the petition area;
- vi. The location of streams, waterbodies, wetlands, drainage courses, riparian areas, critical environmental areas and hazards, and flood plains;
- vii. The planning objectives and design considerations used to determine the use and configuration of the proposed development;
- viii. A conceptual site plan showing the various existing and proposed types of land uses, depicting the relationship to each other and to surrounding uses, proposed acreage, character, and densities/intensity of development for each type of use, and proposed open spaces. The site plan shall be in the form of a “bubble map” locating these “development areas” and other required elements in an approximate fashion;
- ix. A general description of the traffic and pedestrian circulation system proposed for the petition area, showing connections between land uses, neighborhoods, and proposed public schools, parks, open space areas, and trails/bikeways;
- x. A traffic study to determine the impacts of the proposed development on the transportation system;
- xi. A general description of the utility system layout;
- xii. An explanation of any unique features of the proposed development;
- xiii. An analysis of offsite impacts to utilities and public services, including schools and fire and police services;
- xiv. A detailed discussion of conformance with the Girdwood Area Plan, the Girdwood Commercial Areas and Transportation Master Plan, the Areawide Trails Plan, and other applicable Girdwood area planning documents;
- xv. A general development schedule and phasing plan, if any, and approximate date for commencement of construction; and

- xvi. If the petition area contains wetlands designated in the *Anchorage Wetlands Management Plan*, the applicant shall submit:
 - (A) A wetlands delineation study based on the evaluation techniques contained in the *Corp of Engineers Wetlands Delineation Manual*;
 - (B) Hydrologic information specifying the quality, amount and direction of flow of surface and subsurface water, as well as information on the drainage impacts of the development on adjacent property;
 - (C) Vegetation information indicating the distribution of wetland, coniferous and deciduous species; and
 - (D) Habitat information on the type, number, and species of animals, including birds.
- xvii. A general study of existing and proposed drainage, and impacts to natural features, habitat, vegetation, and riparian areas, using baseline climatic and environmental data that reflects Girdwood conditions.

f. ***Director Review, Report, and Recommendation***

The director shall review the proposed area master plan in light of the approval criteria of subsection 4., below, and shall distribute the application to other reviewers as necessary. Based on the results of the reviews, the director shall provide a report and recommendation to the planning and zoning commission.

g. ***Public Hearing***

Published, written, and posted notice of public hearings on area master plans shall be provided in accordance with section 21.03.020H.

h. ***Review and Action by Planning and Zoning Commission***

The planning and zoning commission shall hold a public hearing on the proposed area master plan and, at the close of the hearing, act to approve the plan as submitted, approve the plan subject to conditions or modifications, remand the plan to the applicant for modifications, or deny the plan, based on the approval criteria of subsection 4., below.

4. **Approval Criteria**

An area master plan may be approved if the planning and zoning commission finds all of the following criteria have been met:

- a. The area master plan substantially conforms to the principles and objectives of the Girdwood Area Plan, any approved neighborhood, district, or area plans, and the general purposes of this chapter as stated in section 21.09.010;
- b. The streets, roads, and other transportation elements are in conformance with applicable transportation plans;
- c. The development has no substantial adverse fiscal impact on the Municipality;
- d. The development provides significant community benefits in terms of design, community facilities, open space, and other community amenities;
- e. The development is compatible with the character of the surrounding area and minimizes any potential adverse impacts to surrounding areas to the maximum extent feasible; and

- f. Sufficient public safety, transportation, and utility facilities and services are available to serve the subject property at the proposed level of development, while maintaining sufficient levels of service to existing and anticipated development in surrounding areas.

5. Effect of Area Master Plan Approval

No development rights are granted by the approval of an area master plan. An approved area master plan allows the applicant to file applications for development within the plan area including, but not limited to, site plans, conditional use permits, or preliminary subdivision plans. An approved area master plan also creates a presumption that design density, uses, and site layout set forth in the plan are acceptable to the municipality, subject to further review and application of relevant regulations in the review of subsequent applications. However, approval of the area master plan shall not guarantee such density and uses are attainable.

6. Modification of Area Master Plan Approval

a. *Modification without Public Hearing*

By request of the applicant or subsequent landowner, an approved area master plan may be modified by the planning and zoning commission, without a public hearing, if the modification proposes:

- i. A change to the development schedule or phasing plan of not more than seven years (applicable only if a development master plan is not also required);
- ii. Changes of 10 percent or less to the number of dwelling units or the total combined floor area of commercial and industrial uses;
- iii. A shift between development areas of 10 percent or less of the number of dwelling units or the total combined floor area of commercial and industrial uses;
- iv. A change to the acreage of any development area of 10 percent or less; or
- v. A change the planning and zoning commission determines does not change the impacts on the surrounding neighborhood and public infrastructure and services.

b. *Modification with Public Hearing*

By request of the applicant or subsequent landowner, an approved area master plan may be modified by the planning and zoning commission, only after a public hearing, if the modification proposes:

- i. A change to the development schedule or phasing plan of more than seven years (applicable only if a development master plan is not also required);
- ii. A reduction of acreage of open space;
- iii. Changes to the number of dwelling units or the total combined floor area of commercial and industrial uses of more than 10 percent but less than 25 percent;
- iv. A shift between development areas of more than 10 percent but less than 25 percent of the number of dwelling units or the total combined floor area of commercial and industrial uses;

- v. A change to the acreage of any development area of more than 10 percent but less than 25 percent;
- vi. A change to any conditions of approval imposed by the planning and zoning commission at the time of area master plan approval; or
- vii. A change the planning and zoning commission determines changes the type and/or amount of impact on the surrounding neighborhood and public infrastructure and services.

c. *New Application Required*

The planning and zoning commission shall not consider an application for modification of an area master plan, and the applicant shall be directed to file a new application for area master plan approval, if the modification proposes:

- i. Changes to the number of dwelling units or the total combined floor area of commercial and industrial uses of 25 percent or more;
- ii. A shift between development areas of 25 percent or more of the number of dwelling units or the total combined floor area of commercial and industrial uses;
- iii. A change to the acreage of any development area of 25 percent or more; or
- iv. A change the planning and zoning commission determines substantially changes the types of uses, the intensity of use, or the area of the area master plan.

7. Abandonment of Area Master Plan

An area master plan approval shall expire if:

- a. Implementation of the area master plan schedule is delayed for more than seven years without a request for a schedule modification as outlined in subsections 21.09.030E.6.a. or 21.09.030E.6.b. (applicable only if a development master plan is not also required); or
- b. The property owner notifies the planning and zoning commission of the abandonment of the area master plan approval.

F. Development Master Planning

1. Purpose

A development master plan is intended to shape and manage future growth of a site and provide certainty to the community by stating a clearly articulated vision for the character, layout, and design of the development of the site. At a minimum, the development master plan shall establish specific circulation systems; specific land uses; site dimensional, design, and development standards; and building design standards for the identified development areas. The intent of this process is for master planned areas to result in development meeting or exceeding the standards of this chapter, reflecting the character of Girdwood and the purposes of this chapter and title 21.

2. Applicability

a. *Mandatory: Girdwood*

An approved development master plan is required prior to development in any of the following Girdwood zoning districts: gC-1, GRST-1, GRST-2; GCR-1, GCR-2, GCR-3.

- b. **Optional**
A development master plan may be developed through this process for any multi-building development within the Municipality.

3. **Procedures**

- a. **Pre-Application Conference**
Before filing and application, an applicant shall request a pre-application conference with the director.
- b. **Community Meeting**
A community meeting may be required.
- c. **Initiation**
An application for approval of a development master plan shall be initiated by the owner of the subject property.
- d. **Application**
Applications for approval of a development master plan shall be submitted to the director and shall contain all information and supporting materials specified in subsection e., below.
- e. **Submittal Requirements**
The design standards proposed in the development master plan may differ from the standards of sections 21.09.060, 070, and 080, as provided in subsection 21.09.030F.4., using the development and design criteria described in subsection 5.g., below.

Submittal requirements are listed below and shall be in either narrative or illustrative form. The director may waive submittal requirements not relevant to the proposed development. The planning and zoning commission and/or the director may require the submission of other information as necessary for the informed exercise of judgment under the criteria for the review of the plan, as set out in subsection 4., below.

- i. The legal description, acreage, and boundaries of the proposed petition area, an explanation of boundary delineation, pursuant to subsection 21.09.030C, if applicable, and a depiction of the area surrounding the petition area;
- ii. A site plan of any existing development, including buildings, roads, utilities, drainage systems, trails, and a general description of existing vegetation;
- iii. The topography of the petition area, with contours lines shown at intervals of four feet or less, including any unique natural or historical features;
- iv. The location of existing streams, water bodies, wetlands, drainage courses, and flood plains, and proposed changes to such features;
- v. A grading plan and detailed study of existing and proposed drainage, using baseline climatic and environmental data that reflects Girdwood conditions;
- vi. A proposed site plan, showing roads, trails, building locations and uses, parking lots, open space, and any other proposed development. The site plan shall include the total number and type of dwelling units, and the total combined floor area of commercial and industrial uses;
- vii. A landscape plan, including vegetation retention areas;

- viii. Floor plans, building elevations, and renderings for all buildings;
- ix. Road cross-sections;
- x. Details of any other development proposed; and
- xi. An implementation schedule.

f. ***Director Review, Report, and Recommendation***

The director shall review the proposed development master plan in light of the approval criteria of subsection 4., below, and shall distribute the application to other reviewers as necessary. Based on the results of the reviews, the director shall provide a report and recommendation to the planning and zoning commission.

g. ***Public Hearing***

Published, written, and posted notice of public hearings on development master plans shall be provided in accordance with section 21.03.020H.

h. ***Review and Action by Planning and Zoning Commission***

The planning and zoning commission shall hold a public hearing on the proposed development master plan and, at the close of the hearing, act to approve the plan as submitted, approve the plan subject to conditions or modifications, remand the plan to the applicant for modifications, or deny the plan, based on the approval criteria of subsection 4., below.

4. **Development and Design Standards**

The development master plan shall establish specific circulation systems; land uses; site dimensional, design, and development standards; and building design standards for its development areas. These elements may set different development standards than those found in title 21 including sections 21.09.060, 21.09.070, and 21.09.080. The development master plan shall list the specific sections of title 21 for which different standards are to be established. Where different standards are approved in the development master plan, those standards shall be applied instead of the corresponding standards in title 21.

5. **Approval Criteria**

A development master plan may be approved if the planning and zoning commission finds all of the following criteria have been met:

- a. The development master plan substantially conforms to the principles and objectives of the *Girdwood Area Plan*, any approved neighborhood, district, or area plans, and the general purposes of this chapter, as stated in section 21.09.010;
- b. The streets, roads, and other transportation elements are in conformance with applicable transportation plans;
- c. The development has no substantial adverse fiscal impact on the municipality.
- d. The development provides significant community benefits in terms of design, community facilities, open space, and other community amenities.
- e. The development minimizes any potential adverse impacts to surrounding residential areas to the maximum extent feasible.
- f. Sufficient public safety, transportation, and utility facilities and services are available to serve the subject property at the proposed level of development, while maintaining sufficient levels of service to existing and anticipated development in the surrounding areas.

- g. The design standards are equivalent to or exceed the generally applicable development standards of sections 21.09.060, .070, and .080, and result in high-quality, environmentally sensitive development in keeping with the *Girdwood Area Plan*, the intent of this chapter, and the character of Girdwood.

6. Modification of Development Master Plan

The planning and zoning commission shall determine whether a proposed modification to an approved development master plan may be approved without a public hearing, may be approved with a public hearing, or is significant enough to require a new development master plan. Dimensional variation(s) from an adopted development master plan standard shall only be allowed if approved as a modification of the development master plan by the commission through this process, and not through a variance process.

7. Abandonment of Development Master Plan

A development master plan approval shall expire if:

- a. Implementation of the development master plan schedule is delayed for more than seven years without a request for a schedule modification as outlined in section 21.09.030F.5.; or
- b. The property owner notifies the planning and zoning commission of the abandonment of the development master plan.

(AO 2012-124(S), 2-26-13; AO 2013-117, 12-3-13)

21.09.040 ZONING DISTRICTS

This section establishes the zoning districts and contains basic information pertaining to zoning districts, primarily general descriptions and district-specific regulations. The following sections 21.09.050 through 21.09.080 set forth the uses allowed within the districts and the dimensional, development, and design standards applying to development in the districts.

A. Zoning Districts Established

Girdwood is divided into the following zoning districts:

TABLE 21.09-1: GIRDWOOD ZONING DISTRICTS ESTABLISHED		
District Type	District Name	District Description
Residential Districts	gR-1	Alyeska Highway Mixed Residential
	gR-2	Single-Family/Two-Family Residential
	gR-2A	Single-Family/Two-Family Residential (Crow Creek Road)
	gR-3	Single-Family/Two-Family Residential
	gR-4	Multiple-Family Residential
	gR-5	Multiple-Family Residential
Commercial Districts	gC-1	Seward Highway/Alyeska Highway Commercial
	gC-2	Girdwood Station/Seward Highway Commercial
	gC-3	Old Townsite Commercial/Residential
	gC-4	Lower Alyeska Highway Commercial
	gC-5	New Townsite South Commercial
	gC-6	Crow Creek Road Commercial/Residential
	gC-7	Townsite Square Commercial
	gC-8	New Townsite North Commercial
	gC-9	East Hightower Commercial/Residential

	gC-10	Upper Alyeska Highway Commercial
Industrial Districts	gl-1	Ruane Road Industrial
	gl-2	Upper Crow Creek Industrial
Resort Use Districts	GRST-1	Original Mountain Base Resort
	GRST-2	New Base Resort
Other Districts	GA	Girdwood Airport
	GOS	Girdwood Open Space
	GIP	Girdwood Institutions and Parks
	GCR-1	Commercial Recreation (Golf Course/Nordic Ski Course)
	GCR-2	Commercial Recreation (Glacier – Winner Creek)
	GCR-3	Commercial Recreation (Crow Creek Historic Mine)
	GDR	Development Reserve
	GRR	Recreation Reserve
	GW	Girdwood Watershed

B. Residential Districts

1. General Description

There are six residential districts in Girdwood. The residential districts primarily permit the development of residential dwelling units of various intensities, although some also permit the development of overnight lodging, child care, religious assembly, community buildings and uses, noncommercial parks, private academic schools and utility facilities. Girdwood-specific site and building design standards are contained in sections 21.09.070 and 21.09.080.

2. Districts

a. gR-1 (Alyeska Highway Mixed Residential) District

i. Location

The gR-1 district is located in two sections along Alyeska Highway from just north of the railroad to just past the junction with Crow Creek Road and encompasses already-sewered, established and largely developed residential neighborhoods characterized generally by single-family detached and two-family development.

ii. Intent

The intent of this district is to continue the existing pattern of development as dwelling units are constructed on the remaining undeveloped lots, and to permit development of hostels, inns and multiple-family housing.

iii. District-Specific Standard

More than one principal structure may be allowed on any lot or tract by administrative site plan review.

b. gR-2 (Single-Family/Two-Family Residential) District

i. Location

The gR-2 district is located in the following three areas:

- (A)** The Mine Roads area west of Alyeska Highway, just north of the railroad;
- (B)** South of Alyeska Highway, west of Timberline Drive; and
- (C)** Alyeska Basin Subdivision, lying north and south of Alyeska Highway, at the base of Mt. Alyeska.

- ii. *Intent*
These are established and largely developed residential neighborhoods characterized by single-family detached and two-family development. The intent is to allow development to continue in a manner consistent and compatible with existing development patterns.
 - iii. *District-Specific Standards*
 - (A) Nonresidential uses may be allowed as provided in table 21.09-2, but shall be allowed only on central sewer, not septic systems.
 - (B) Only one principal structure is allowed on any lot or tract.
- c. ***gR-2A (Single-Family/Two-Family Residential—Crow Creek Road) District***
- i. *Location*
The gR-2A district is located on both sides of Upper Crow Creek Road in Crow Creek Valley, just south of the Girdwood Mine.
 - ii. *Intent*
This area consists of an established, sparsely-developed residential neighborhood characterized by single-family detached development. The intent of this district is to allow development to continue in a manner consistent and compatible with existing development patterns.
 - iii. *Federal Patents to Mineral Estate and Valid State and Federal Mining Claims*
The properties in this district have federal patents to mineral estate and/or valid state and federal mining claims. Mining activity under the auspices of those patents and/or claims shall comply with relevant federal and state regulations.
 - iv. *District-Specific Standards*
 - (A) In spite of section 3.a. below, commercial vehicles, shipping containers, construction equipment, and the like may be stored outdoors in this district.
 - (B) Only one principal structure is allowed on any lot or tract.
- d. ***gR-3 (Single-Family/Two-Family Residential) District***
- i. *Location*
Discrete areas of the gR-3 district are located in the following areas:
 - (A) West of Alyeska Highway, west of the gR-1 district and west of the Mine Roads portion of the gR-2 district; and
 - (B) Both east and west of Crow Creek Road.
 - ii. *Intent*
The gR-3 district is found in a number of areas and consists of undeveloped land designated primarily for single-family detached and two-family development, although other types of residential uses and visitor accommodations may be allowed pursuant to the master planning process and table 21.09-2.
 - iii. *Area Master Planning Required*
 - (A) Prior to subdivision or development of any portion of this district, area master planning is required pursuant to section 21.09.030E.

- (B) Uses allowed in this district are set forth in table 21.09-2. Area master planning shall not change the allowed uses in this district, unless the master plan is adopted concurrently with amendments to the *Girdwood Area Plan* and this chapter.
 - (C) Dimensional standards, site development and design standards, and building design standards for this district are set out in sections 21.09.060, 21.09.070, and 21.09.070, respectively. Area master planning shall not change those standards.
 - iv. *District-Specific Standard*
Unless determined otherwise through an area master plan, only one principal structure is allowed on any lot or tract.
- e. ***gR-4 (Multiple-Family Residential) District***
 - i. *Location*
The district consists of two already-developed areas at the base of Mt. Alyeska, two, small already-developed areas on the west side of Alyeska Highway, and an area south of Alyeska Highway, just east of Glacier Creek.
 - ii. *Intent*
The intent for the gR-4 district is to continue the existing pattern of multiple-family development on sewers. Single-family and two-family development is allowed on existing lots of less than 20,000 square feet.
 - iii. *District-Specific Standard*
More than one principal structure may be allowed on any lot or tract by administrative site plan review.
- f. ***gR-5 (Multiple-Family Residential) District***
 - i. *Location*
The gR-5 district consists of two areas which are:
 - (A) West of Crow Creek Road, just north of California Creek; and
 - (B) East of Crow Creek Road, west of Glacier Creek.
 - ii. *Intent*
This district is intended for multiple-family development on sewers.
 - iii. *District-Specific Standards*
 - (A) *Minimum Density*
The minimum density for residential development where public sewer is available, shall be five dwelling units per acre.
 - (B) *Single-Family Development in gR-5*
One single-family structure is allowed on a parcel only where public sewer is not available. Minimum lot size shall be 50,000 square feet. Subdivision is prohibited for the purpose of providing single-family development.
 - (C) *Multiple Residential Structures*
More than one principal structure may be allowed on any lot or tract by administrative site plan review.

3. District-specific Standards for All Residential Districts

a. *Prohibited Uses and Structures*

Vehicles, shipping containers, construction trailers, and similar items, shall not be used for habitation or storage. Commercial vehicles, shipping containers, construction equipment, and similar items, shall not be stored outdoors in residential districts.

b. *Use of Setbacks*

- i. Structures, including but not limited to fences, trash dumpsters, and storage sheds, shall not be placed within any setback area, except as otherwise provided in this chapter.
- ii. Private vehicles, trailers, boats, snow machines, recreational vehicles, other non-commercial vehicles, and similar items, may be stored in the front setback only in the driveway, but shall not be stored closer than five feet to the side or rear property lines.
- iii. Architectural elements, such as roof overhangs, eaves, and awnings, shall not project more than two feet into a required setback area.
- iv. Decks, unroofed porches, exterior steps, terraces, and similar items, shall not project into setback areas, except exterior steps necessary for site access may project into setback areas.
- v. Walkways may be constructed within setback areas.
- vi. Bed and breakfast signs and project identification signs may be placed in the front setback area.

C. Commercial Districts

1. General Description

There are ten commercial districts in Girdwood, labeled gC-1 through gC-10. The commercial districts permit a varied range of commercial uses, and some of the commercial districts also permit the development of residential dwelling units.

In order to provide adequate review of larger projects, to protect the public interest, prohibit the development of structures out of scale with the character of different parts of Girdwood, and provide flexibility and simplicity of development, certain uses have different review and approval requirements, depending on the size of the use. The sizes and approval requirements are delineated in table 21.09-2.

Girdwood-specific site and building design standards are contained in sections 21.09.070 and 21.09.080.

2. Districts

a. *gC-1 (Seward Highway/West Alyeska Highway Commercial) District*

i. *Location*

The gC-1 district consists of land located north of the Seward Highway, west of the Alyeska Highway, and south of the railroad at the entrance to Girdwood Valley, containing approximately 23 acres.

ii. *Intent*

The overall design goal for this district shall be to create a mix of rail, bus, trail, and highway-related commercial uses. This district may be a possible site for a passenger terminal, trailhead for the Iditarod trail and/or a transfer point between private autos and carpools, buses, or other forms of transportation. The district contains intertidal and high value freshwater

wetlands, and also has high visibility. Consequently, the master plan for this district needs to carefully consider both environmental and community aesthetics. This district shall become an attractive gateway to Girdwood Valley, with visual character appropriate to the entry to a mountain resort community. Landmark-quality elements are encouraged in any development visible from the highways, and the design of larger buildings shall make every effort to reduce the perception of building mass and make the building appear to be an aggregation of smaller, simple forms.

iii. *Development Master Planning Required*

(A) Prior to subdivision or development of any portion of this district, development master planning is required pursuant to section 21.09.030F.

(B) Subject to section 21.09.030F., the development master plan may change the dimensional standards, site development and design standards, and building design standards for this district set forth in sections 21.09.060, 21.09.070, and 21.09.080, respectively.

(C) Development proposals that are part of an approved development master plan are exempted from the review and approval requirements of table 21.09-2, except when required as a condition of approval.

iv. *District-Specific Standards*

(A) The façade of any retail commercial development or multimodal facility facing the Seward Highway or Alyeska Highway shall avoid a “back-door” appearance.

(B) Building and landscape materials typical of Girdwood, such as natural wood, native trees and flowers, and local stone, shall be emphasized.

b. ***gC-2 (Girdwood Station/Seward Highway Commercial) District***

i. *Location*

The gC-2 district is comprised of land on the east side of Alyeska Highway, west of Dawson Street, at the intersection of the Alyeska Highway with the Seward Highway. The district fronts both highways.

ii. *Intent*

The gC-2 district, along with the gC-1 district, constitutes the entry to Girdwood Valley and shall be developed as part of an attractive gateway to a mountain resort community. Because of the proximity to the Seward Highway, residential uses are not appropriate in this district. Landmark-quality elements are encouraged in any development visible from the highways, and the design of larger buildings shall make every effort to reduce the perception of building mass and make the building appear to be an aggregation of smaller, simple forms.

iii. *District-Specific Standards*

Building and landscape materials, such as natural wood, native trees and flowers, and local stone, shall be emphasized.

c. ***gC-3 (Old Townsite Commercial/Residential) District***

i. *Location*

The gC-3 district is comprised of the land north of the gC-2 district, east of the Alyeska Highway, south of the Alaska Railroad, and west of Glacier Creek at the entrance to Girdwood Valley.

- ii. *Intent*

This district reflects the development pattern of early Girdwood, with a mix of houses and small businesses on small lots creating the appearance of a small, historic town. There are still many vacant lots in this district to be developed with either residences or small commercial and craft-oriented businesses to retain the unique scale and visual quality of this district.
- iii. *District-Specific Standards*
 - (A) *Residential Character*

To maintain overall neighborhood integrity, new nonresidential development in the old townsite shall have a residential character, even though the zoning permits commercial uses. Elements of residential character in the old townsite include predominantly pitched roofs, porches and protected entryways, rectangular and vertically oriented windows recessed into the exterior wall or window trim, no blank walls, and special attention to the detailing of windows, doors, porches and protected entries on the ground floor. Siding and trim shall be traditional residential in appearance, and avoid materials associated with industrial uses.
 - (B) *Parking*

On-street parking may satisfy parking requirements; excessive on-site parking is discouraged. Up to 50 percent of the width of the front setback may be used for parking, provided parking lots allow for sidewalks so pedestrians may comfortably and safely walk by parking stalls.
 - (C) *Accessory Structures and Outdoor Storage*

Uses shall adhere to residential district standards for outdoor storage and accessory structures.
- d. ***gC-4 (Lower Alyeska Highway Commercial) District***
 - i. *Location*

The gC-4 district consists of three commercially developed lots located on the west side of Alyeska Highway, south of Crow Creek Road, surrounded by residential uses.
 - ii. *Intent*

This district permits continued commercial use or a variety of residential uses. Use and redevelopment of the lots in this district shall protect the visual quality of the Alyeska Highway corridor by maintaining and enhancing the predominantly natural character of views along the highway.
 - iii. *District-Specific Standards*

Removal of existing vegetation shall be in accordance with section 21.09.070D.4.b.
- e. ***gC-5 (New Townsite South Commercial) District***
 - i. *Location*

The gC-5 district consists of previously-platted land between Glacier Creek and California Creek, south of Alyeska Highway, owned, at the time this chapter is adopted, by the Municipality. Although this district is identified as a commercial district, it also includes park, open space, and institutional lands, with boundaries proposed to be modified through a detailed master plan process.

- ii. *Intent*

This district is the southern extension of the new townsite. Development in this district is intended to include a blending of commercial, institutional and park uses, with new and modified access routes established. Small commercial lots are anticipated along the extension of south Hightower, where a main street character, similar to the north townsite area, is intended. This may differ from larger lot commercial development at the south end of the commercial district, where a larger structure (grocery store) is anticipated. Although buildings are likely to be larger than in new townsite areas north of the Alyeska Highway, the desired character is expected to be compatible with Girdwood's mining town origins, using elements such as human-scale building massing; varied rooflines; protected entries; traditional window forms; well-detailed retail frontages; and use of natural materials.
- iii. *Area Master Planning Required*
 - (A) Prior to subdivision or development of any portion of this district, area master planning is required pursuant to section 21.09.030E.
 - (B) Uses allowed in this district are set forth in table 21.09-2. Area master planning shall not change the allowed uses in this district, unless the master plan is adopted concurrently with amendments to the *Girdwood Area Plan* and this chapter.
 - (C) Dimensional standards, site development and design standards, and building design standards for this district are set forth in sections 21.09.060, 21.09.070, and 21.09.070, respectively. Area master planning shall not change those standards.
- f. ***gC-6 (Crow Creek Road Commercial/Residential) District***
 - i. *Location*

The gC-6 district is located north of Alyeska Highway, along both sides of lower Crow Creek Road, and along Hightower Road north of the new Townsite.
 - ii. *Intent*

The intent for this district is to continue the existing pattern of mixed residential and commercial uses, while allowing expansion of the new townsite core.
- g. ***gC-7 (Townsite Square Commercial) District***
 - i. *Location*

The gC-7 district is a square block located north of the Alyeska Highway, bounded by Hightower Road, Lindblad Avenue, Holmgren Place, and Girdwood Place. This district presently consists of small lots developed with commercial uses.
 - ii. *Intent*

This district is intended to be the commercial core of Girdwood, with commercial uses developed at street level, although residential dwelling units may be constructed over the ground floor commercial uses. Buildings shall be at human scale and relate strongly to both the street front and to the town square park, in order to support the park as a public amenity. Site development shall provide strong pedestrian connections to neighboring lots.
 - iii. *District-specific Standards*
 - (A) *Building Orientation*

Buildings shall be oriented perpendicular to, or parallel with, public streets and to other buildings.

- (B) *Double-Loaded or Double-Sided Commercial*
Buildings with frontage on Town Square Park shall be designed and constructed so ground floor commercial, retail and/or restaurant establishments shall have public/customer spaces and a public entrance facing Town Square Park, as well as on the front side.
- (C) *Rear Setbacks and Relationship to Town Square Park*
Uses allowed in the rear setback, facing Town Square Park, shall focus on public activity rather than being fully private or service areas. Outdoor spaces and structures, such as terraces, porches, and decks, may encroach into the rear setback. Service areas or mechanical equipment in the rear are discouraged and, if unavoidable, shall be screened from the park.
- (D) *Side Setbacks along Public Rights-of-Way Accessing Town Square Park*
Building or structural improvements are allowed within the side setback if related to the public space, under the following standards:
- (1) No blank building walls or sight-obstructing fences are allowed.
 - (2) There shall be at least one building public entry facing the public access right-of-way, with a connecting walkway.
 - (3) The side of the building facing the public access right-of-way shall meet the design standards for store fronts in subsection 21.09.080F.2.f.
 - (4) Non sight-obscuring fences, such as picket fences, and garden gates no higher than 42 inches in height are allowed.
- (E) *Fences*
Privacy walls or fences, that shall match the materials of the principal building on the lot, are permitted only around private terraces on the ground floor, or to screen service areas. Fences bordering the public rights-of-way into Town Square Park are permitted subject to subsection (D), above.
- (F) *Snow Storage Areas*
Snow storage areas in the side and rear setbacks shall be designated to not interfere with or damage public spaces or passageways between buildings.
- (G) *Parking*
In addition to the more generally applicable standards for parking, development in the gC-7 district is subject to the new townsite parking provisions of subsection 21.09.070K.3. Driveways are prohibited along side setbacks adjoining the public rights of way accessing Town Square Park.

- h. gC-8 (New Townsite North Commercial) District**
- i. Location**
The gC-8 district is located north of Lindblad Avenue, on both sides of Hightower Road. This district includes the Girdwood Post Office and neighboring lots to the north, east, and west.
- ii. Intent**
The intent of this district is for northward commercial and residential expansion of the new townsite core. Buildings shall continue the human scale and physical character of the new townsite core, and maintain a strong relationship to the street. Properties along Hightower Road shall express a visible transition from the built-up environment around town square to a more forested landscape along the northern extension of Hightower Road. Residential dwelling units are permitted on upper floors above ground-floor commercial uses.
- i. gC-9 (East Hightower Commercial/Residential) District**
- i. Location**
The gC-9 district is located north of Alyeska Highway, east of Hightower Road and west of Glacier Creek. This district presently is a mix of commercial and residential uses.
- ii. Intent**
It is intended to provide expansion area for the new townsite core, continuing a mixture of multiple-family residential and commercial uses. Buildings shall be at human scale. Site development shall have strong street orientation and provide pedestrian connections to neighboring lots.
- j. gC-10 (Upper Alyeska Highway Commercial) District**
- i. Location**
The gC-10 district is an undeveloped portion of a residentially developed subdivision. This district is located on the south side of Alyeska Highway, west of Timberline Drive.
- ii. Intent**
The intent of this district is to permit development of a limited range of non-retail commercial uses along with residential uses in a manner compatible with the surrounding residential land use.
- iii. District-specific Standards**
- (A) General Manufacturing Use**
This use shall comply with the Commercial, Resort and Public/Institutional Building Design Standards in subsection 21.09.080F.

3. District-Specific Standards for Commercial Districts

The following standards shall apply to commercial districts.

- a. Ground-floor Residential**
In the gC-2, gC-5, gC-7, and gC-8 commercial districts, residential uses are permitted only on an upper story above the ground floor. Commercial and/or other non-residential uses shall occupy the ground floor.
- b. Arcades and Covered Walkways in the New Girdwood Townsite**
In the gC-5, gC-7, gC-8 and gC-9 districts, arcades or roofed walkways are required along the street face of all new buildings and as part of any application for modification or redevelopment. In the gaps between buildings within these districts, privately maintained walkways are required. Development standards for

arcades and walkways on building frontages are established in subsection 21.09.080E.5.d.

c. Use of Setbacks in Commercial Districts

- i. Service facilities, such as trash dumpsters, storage sheds, fuel tanks, and similar facilities, shall not be placed within setback areas.
- ii. No parking spaces are permitted within required setbacks, except in the gC-3 district with its small lots and existing businesses, where up to 50 percent of the width of the front setback may be used for parking.
- iii. Business signs, walkways, snow protection over walkways and landscape plantings may be placed within, and driveways may cross, setback areas.
- iv. Except for arcaded or roofed walkways, no architectural elements attached to a building, such as roofed decks or terraces, roof overhangs, attached exterior stairs and upper-story balconies, shall project more than two feet into a setback area. On lots smaller than 5,000 sq. ft., however, where parking access is only from the rear service alley, the garage and its roof overhang may encroach into the setback to within five feet of the property line.
- v. Walkways and terraces may use up to 50 percent of the side and rear setback, and may occupy all of the front setback area not required for snow dumping from roofs and for snow storage from paved areas.

D. Industrial Districts

1. General Description

There are two industrial districts in Girdwood, labeled gl-1 and gl-2. The gl-1 district, the Ruane Road industrial area, permits a varied range of commercial and industrial uses. The gl-2 district, encompassing the existing industrial mining area along Upper Crow Creek Road, primarily permits continuation of the existing use, along with a limited number of other uses. Girdwood-specific site and building design standards are contained in sections 21.09.070 and 21.09.080.

2. Districts

a. gl-1 (Ruane Road Industrial) District

- i. *Location*
The gl-1 district consists of the Ruane industrial area east of lower Alyeska Highway.
- ii. *Intent*
This largely undeveloped area is intended to contain the industrial uses necessary for the future development of Girdwood. In addition, commercial uses requiring large areas for storage, or with potentially more substantial visual and noise impacts than appropriate for the Girdwood commercial districts, are permitted in this district.

b. gl-2 (Upper Crow Creek Industrial) District

- i. *Location*
The gl-2 district is an active commercial mine at the upper end of Crow Creek Road.
- ii. *Intent*
The intent for this district is to permit continuation of existing mining activities and accessory activities thereto.

- iii. *Federal Patents to Mineral Estate and Valid State and Federal Mining Claims*
The properties in this district have federal patents to mineral estate and/or valid state and federal mining claims. Mining activity under the auspices of those patents and/or claims shall comply with relevant federal and state regulations.

E. Resort Districts

1. General Description

There are two resort districts in Girdwood, labeled gRST-1 and gRST-2, focused on tourism and alpine skiing. The gRST-1 district consists of the area around the existing day lodge, referred to as the original mountain base resort. The gRST-2 district consists of the Alyeska Resort ski slopes, the Alyeska Prince Hotel area, and undeveloped property for future resort expansion. The resort districts permit a varied range of commercial uses and residential dwelling units.

In order to provide adequate review of larger projects, to protect the public interest, prohibit the development of structures out of scale with the character of different parts of Girdwood, and provide flexibility and simplicity of development, certain uses have different review and approval requirements, depending on the size of the use. The sizes and approval requirements are delineated in table 21.09-2.

2. Districts

a. **GRST-1 (Original Mountain Base Resort) District**

i. *Location*

The gRST-1 district consists of the original Alyeska Resort base area, currently in multiple ownership, and already largely developed with commercial uses generally related to the alpine ski facility.

ii. *Intent*

The intent of this district is to continue its use as an alpine ski resort base area, particularly for day skiers.

iii. *Development Master Planning Required*

(A) Prior to any development of over 20,000 square feet gross floor area, development master planning is required pursuant to section 21.09.030F.

(B) Uses allowed in this district are set forth in table 21.09-2. Development master planning shall not change the allowed uses in this district, unless the master plan is adopted concurrently with amendments to the Girdwood Area Plan and this chapter.

(C) Subject to section 21.09.030F., the development master plan may change the dimensional standards, site development and design standards, and building design standards for this district set forth in sections 21.09.060, 21.09.070, and 21.09.080, respectively.

(D) Development proposals that are part of an approved development master plan are exempted from the review and approval requirements of table 21.09-2, except when required as a condition of approval.

b. **GRST-2 (New Base Resort) District**

i. *Location*

The gRST-2 district consists of the Alyeska Resort ski slopes, the Alyeska Prince Hotel and adjoining parking lot, the undeveloped area between the

original mountain base area and the Alyeska Prince Hotel, and an undeveloped area lying north of the Alyeska Prince Hotel, across Moose Meadows Creek. The latter area is suitable for a future resort base development.

- ii. *Intent*
The intent of this district is to maintain and expand upon the current development for alpine skiing and tourism.
- iii. *Area Master Planning and Development Master Planning Required*
 - (A) *Area Master Planning*
 - (1) Prior to any development of over 20,000 square feet gross floor area, area master planning is required pursuant to section 21.09.030E.
 - (2) Uses allowed in this district are set forth in table 21.09-2. Area master planning shall not change the allowed uses in this district, unless the master plan is adopted concurrently with amendments to the Girdwood Area Plan and this chapter.
 - (B) *Development Master Planning*
 - (1) Prior to any development of over 20,000 square feet gross floor area, development master planning is required pursuant to section 21.09.030F.
 - (2) Uses allowed in this district are set forth in table 21.09-2. Development master planning shall not change the allowed uses in this district, unless the master plan is adopted concurrently with amendments to the *Girdwood Area Plan* and this chapter.
 - (3) Subject to section 21.09.030F., the development master plan may change the dimensional standards, site development and design standards, and building design standards for this district set forth in sections 21.09.060, 21.09.070, and 21.09.080, respectively.
 - (4) Development proposals that are part of an approved development master plan are exempted from the review and approval requirements of table 21.09-2, except when required as a condition of approval.

F. Other Districts

1. General Description

There are nine miscellaneous districts in this section covering the majority of the land governed by this chapter. Several districts consist of discrete, relatively small areas. For instance, the GA (Girdwood Airport) district consists of State of Alaska property presently used for the Girdwood Airport, and the GCR-3 Commercial Recreation (Crow Creek Historic Mine) district consists of property operated as historic Crow Creek mine commercial/recreational development. On the other hand, some of the districts cover extensive areas of land and/or are located in a variety of areas within Girdwood. For instance, the GIP (Girdwood Institutional and Parks) district includes Girdwood School, U.S. Forest Service ranger station and visitor center, State of Alaska highway maintenance yard, and municipal sewage treatment plant, along with both dedicated and undedicated existing and future parks. Many of the districts are based on intended general uses specified in the Girdwood Area Plan, but require master planning to identify specific uses

and development standards, as well as circulation, subdivision and utility requirements. It is anticipated, as required master plans for land in many of the districts in this chapter are completed, the specific district provisions may be refined or the district may be completely redefined.

2. GA (Girdwood Airport) District

a. Location

The GA district consists of State of Alaska-owned property where the Girdwood airport is currently located. The airport property is located north of Alyeska Highway and straddles Glacier Creek. The airport facility itself is on the east side of Glacier Creek, but much of the airport property is either wetlands or river floodway.

b. Intent

The intent of this district is for continuation of uses that are primarily aviation related, but also for wetlands and river floodway to be minimally disturbed by development within this district.

3. GOS (Girdwood Open Space) District

a. Location

The GOS district consists of those areas of Girdwood Valley depicted in the Girdwood Area Plan as open space because of generally physically unsuitable or unsafe for development, and/or generally environmentally sensitive with functions or attributes to be protected. The GOS district is located throughout the valley, taking in several types of land area, including wetlands and floodplains, steep slopes and hazardous lands, as well as recommended creek greenbelt areas.

b. Intent

The intent of the open space district is to protect lands left predominantly natural.

c. District-Specific Standards

Development shall be prohibited, except as related to a recreational use listed in table 21.09-2, or if authorized in an approved master plan. Transportation rights of way and utility easements may cross GOS lands.

4. GIP (Girdwood Institutions and Parks) District

a. Location; Parks Designation

The GIP (Girdwood Institutions and Parks) district consists of land in public use, or projected to be in public use, during the duration of the Girdwood Area Plan. Among other uses, the Girdwood school, the U.S. Forest Service ranger station and visitor center, State of Alaska highway maintenance yard, and municipal sewage treatment plant, along with both dedicated and undedicated existing and future parks, are located in this district.

Within the GIP district, parks, whether dedicated or undedicated, existing or future, are designated on the district map by "GIP-p."

b. Intent

The GIP district is intended to include areas of public and quasi-public institutional uses and activities.

c. Federal Patents to Mineral Estate and Valid State and Federal Mining Claims

Some properties in this district have federal patents to mineral estate and/or valid state and federal mining claims. Mining activity under the auspices of those patents and/or claims shall comply with relevant federal and state regulations.

- d. **Uses**
- i. **Permitted Uses**
The following uses are allowed subject to the stated limitations:
- (A) Park facilities and playgrounds.
 - (B) Community fairs and special events, subject to obtaining any required temporary use permits.
 - (C) Concession facilities not larger than 500 square feet, primarily serving users of the park or open space where located.
- ii. **Conditional Uses**
- (A) Gallery/ museum/art studio/information center.
 - (B) Community buildings and uses.
 - (C) Tent campgrounds; only in California Creek Park.
 - (D) Communication structures (as listed in table 21.09-2).
 - (E) Utility facilities and utility substations.
 - (F) Non-motorized general outdoor recreation, commercial.
 - (G) Snow disposal site.
 - (H) Governmental service.
- e. **District-specific Standards**
- i. The provisions of subsection 21.09.030D.1., *Minor Modifications for Site Constraints*, apply to the GIP district.
- ii. The provisions of subsection 21.09.040C.3.c., *Use of Setbacks in Commercial Districts*, apply to the GIP district.

5. **GCR-1 Commercial Recreation (Golf Course/Nordic Ski Course) District**

- a. **Location**
The area encompassed by this district is located in lower Girdwood Valley near Glacier, California, and Virgin Creeks.
- b. **Intent**
The primary use envisioned for the district is an eighteen-hole resort golf course and facilities normally associated with a golf course, including a clubhouse, driving range, pro/retail shop, restaurant/food service, and similar supporting services. A Nordic ski course is also a permitted use. Other uses associated with the course development may include limited related commercial and/or other recreational activities. Residential development may also be allowed as a secondary use, along with other outdoor recreational uses and facilities. While this district provides for commercial recreation development with related residential, the intent is to also maintain the scenic and natural beauty of the area, and to ensure development impacts are minimized. No housing or commercial development shall be constructed until after the golf course is constructed.
- c. **Area Master Planning and Development Master Planning Required**
- i. **Area Master Planning**
Except for uses listed in subsection d., below, no subdivision or other development of land within this district shall occur before an area master

plan is approved pursuant to section 21.09.030.E. The plan shall address protection of important environmental features and natural habitat.

ii. *Development Master Planning*

(A) Except for the three privately owned lots in this district and the uses listed in subsection d., below, the uses allowed in the district, as well as the design and character of the development permitted within the district, shall be established through development master planning pursuant to section 21.09.030F.

(B) Subject to section 21.09.030F., the development master plan may change the dimensional standards, site development and design standards, and building design standards for this district set forth in sections 21.09.060, 21.09.070, and 21.09.080, respectively.

d. **Uses**

i. *Permitted Uses*

The following uses are permitted, prior to area and/or development master plan approval, subject to compliance with all development and design standards and other applicable regulations:

(A) Public recreational trails.

(B) Single family dwelling on Lots 1 and 13, Block 7, and Lot 1, Block 10, First Addition New Girdwood Townsite Alaska Subdivision.

ii. *Conditional Uses:*

The following uses may be permitted as conditional uses, prior to area and/or development master plan approval:

(A) Community buildings and uses.

(B) Utility facilities and utility substations.

6. **GCR-2 Commercial Recreation (Glacier – Winner Creek) District**

a. ***Location***

The area encompassed by this district is located in the upper portion of Girdwood Valley and includes municipal, as well as state-owned and selected land, in the Glacier and Winner Creek drainages and mountain massif between the two creeks. This undeveloped area is mountainous and heavily forested.

b. ***Intent***

The primary use permitted for this area is outdoor commercial recreational use, including associated resort development. While the intent of this district is to provide for commercial recreation and resort development, the emphasis is to maintain the scenic and natural beauty of the area, and to ensure development impacts are balanced with environmental concerns.

c. ***Area Master Planning and Development Master Planning Required***

i. *Area Master Planning*

Except for uses listed in subsection d., below, no subdivision or other development of land within this district shall occur before an area master plan is approved pursuant to section 21.09.030E. The plan shall address protection of important environmental features and natural habitat.

ii. *Development Master Planning*

(A) Except for the uses listed in subsection d., below, the uses allowed in the district, as well as the design and character of the

development permitted within the district shall be established through development master planning pursuant to section 21.09.030F.

- (B) Subject to section 21.09.030F., the development master plan may change the dimensional standards, site development and design standards, and building design standards for this district set forth in sections 21.09.060, 21.09.070, and 21.09.080, respectively.

iii. *Master Plan Standards*

Both area and development master planning standards for resort areas shall take into consideration the following:

- (A) Traffic into the Four Corners area shall be minimized, and preferably restricted to some form of mass transit, such as shuttle bus, or ultimately an automated system.
- (B) Any road into the Four Corners area shall be curvilinear and aesthetically designed and landscaped.
- (C) Removal of trees and vegetation shall be kept to a minimum.
- (D) Development shall be hidden and designed to fit in with the area.
- (E) As much buffer/open space as possible shall be retained between the development and the creeks.

d. *Uses*

i. *Additional Development and Design Standards*

Due to the remote location and natural undeveloped features of this district, all permitted and conditional uses may be subject to additional design and development standards to ensure compatibility with the natural environment.

ii. *Permitted Uses*

The following uses are permitted, prior to area and/or development master plan approval, subject to compliance with all development and design standards and other applicable regulations:

- (A) Passive and Active Outdoor Recreation.
- (B) Sno-cat skiing.

iii. *Conditional Uses*

The following uses may be permitted as conditional uses, prior to area and/or development master plan approval:

- (A) Community buildings and uses.
- (B) Small scale lodging or shelters, not to exceed an aggregate total of 5,000 square feet gross building area.
- (C) Utility facilities and utility substations.

7. **GCR-3 Commercial Recreation (Crow Creek Historic Mine) District**

a. *Location*

This district is located along the lower portion of Crow Creek a short distance upstream from its confluence with Glacier Creek, in the upper portion of Girdwood

Valley. The area encompassed by this district contains the remains of the historic Crow Creek Mine and surrounding environs.

b. Intent

The intent for this district is to allow the current uses to continue. This district contains several restored historic structures being used in a variety of ways, including historical/cultural exhibit, gift shop, overnight accommodations, social/recreational activities and owners' residences. Residences are allowed customary accessory uses, including the keeping of pets and/or livestock. Along with recreational and small commercial mining and overnight camping, these uses make this district a multi-faceted visitor attraction.

c. Federal Patents to Mineral Estate and Valid State and Federal Mining Claims

The properties in this district have federal patents to mineral estate and/or valid state and federal mining claims. Mining activity under the auspices of those patents and/or claims shall comply with relevant federal and state regulations.

d. Area Master Planning and Development Master Planning Required

i. Area Master Planning

Except for the uses listed in e. below, subdivision, new development, or major expansions of existing operations are permitted only in accord with area master planning approval pursuant to section 21.09.030E.

ii. Development Master Planning

(A) Prior to additional development, development master planning approval, pursuant to section 21.09.030F, is required in order to ensure high-quality, environmentally sensitive development in keeping with the intent of this chapter 21.09 and the character of Girdwood.

(B) Subject to section 21.09.030F, the development master plan may change the dimensional standards, site development and design standards, and building design standards for this district that are set forth in sections 21.09.060, 21.09.070, and 21.09.080 respectively.

e. Uses

i. Permitted Uses

The following uses are permitted subject to compliance with all development and design standards and other applicable regulations:

(A) Restoration of existing structures for uses already established on site.

(B) Three additional single-family dwellings constructed after the effective date of this chapter.

(C) Utility substations.

ii. Conditional Uses

The following uses may be permitted as conditional uses:

(A) Community buildings and uses.

(B) Utility facilities.

f. District-Specific Standards

i. Additional Development and Design Standards

The single-family structures, community buildings and uses, and utility facilities shall comply with the dimensional standards for the gR-2 District (Single-Family/Two-Family Residential). Restoration of existing structures shall be based upon original design. For other new structures, development standards shall be determined through the development master plan process.

8. GDR Development Reserve District

a. Location

This district consists of municipally-owned land located on the eastern side of lower Girdwood Valley, between Virgin Creek and the Seward Highway, municipally-owned land located in the upper Girdwood Valley, between Crow Creek Road and Glacier Creek, and two areas north of Glacier Creek and east of Crow Creek.

b. Intent

The intent of this district is to hold lands in reserve for future development.

c. Prerequisites to Development

Prior to any development in this district, other than the uses permitted in subsection e., below, this district shall be revised on the Girdwood Area Plan Land Use Plan Map from development reserve to an active classification. In addition, this section shall be amended to either move the land into another district classification, or adopt specific uses and standards for development of the land in this district.

d. Area Master Planning and Development Master Planning Required

i. Area Master Planning

Except for the uses permitted in subsection e., below, no subdivision or other development of land within this district shall occur before an area master plan is approved pursuant to section 21.09.030E.

ii. Development Master Planning

(A) Except for the uses listed in subsection e., below, the uses allowed in the district, as well as the design and character of the development permitted within the district, shall be established through development master planning, pursuant to section 21.09.030F.

(B) Subject to section 21.09.030F., the development master plan may change the dimensional standards, site development and design standards, and building design standards for this district set forth in sections 21.09.060, 21.09.070, and 21.09.080, respectively.

e. Uses

i. Permitted Uses prior to Master Planning Approval

Public trails, as depicted in an adopted trails or open space master plan.

ii. Conditional Uses prior to Master Planning Approval

The following uses may be permitted as conditional uses:

(A) Community buildings and uses.

(B) Utility facilities and utility substations.

9. **GRR (Recreation Reserve) District**

a. ***Location***

This district consists of municipally-owned land located in upper Girdwood Valley, between Glacier Creek on the west and the lower slope of Mount Alyeska on the east. This district is located south of the Four Corners Park and north of the areas designated for resort development. This district is generally a mixed spruce/hemlock-forested upland interlaced with extended, open, wet meadows. Because of its close proximity to current and proposed resort development areas, this district is well located to provide recreational opportunities for visitors, as well as local residents.

b. ***Intent***

The intent of this district is to hold lands in reserve for future development of recreational opportunities.

c. ***Prerequisites to Development***

Prior to any development in this district, other than the uses permitted in subsection e., below, this district shall be revised on the *Girdwood Area Plan* land use plan map from recreation reserve to an active classification. In addition, this section shall be amended to either move the land into another district classification, or adopt specific uses and standards for development of the land in this district.

d. ***Area Master Planning and Development Master Planning Required***

i. ***Area Master Planning***

Except for the uses permitted in subsection e., below, no subdivision or other development of land within this district shall occur before an area master plan is approved pursuant to section 21.09.030E.

ii. ***Development Master Planning***

(A) Except for the uses listed in subsection e., below, the uses allowed in the district, as well as the design and character of the development permitted within the district, shall be established through development master planning pursuant to section 21.09.030F.

(B) Subject to section 21.09.030F., the development master plan may change the dimensional standards, site development and design standards, and building design standards for this district set forth in sections 21.09.060, 21.09.070, and 21.09.080, respectively.

e. ***Uses***

i. ***Permitted Uses prior to Master Planning Approval***

Public trails, as depicted in an adopted trails or open space master plan.

ii. ***Conditional Uses prior to Master Planning Approval***

The following uses may be permitted as conditional uses:

(A) Community buildings and uses.

(B) Utility facilities and utility substations.

10. **GW (Girdwood Watershed) District**

a. ***Location***

The GW district consists of federally owned, state-selected land within the Crow Creek and Winner Creek watersheds.

- b. **Intent**
The intent of the watershed district is to identify remote lands generally to be left natural. The primary use of watershed land is water supply protection and recreation.
- c. **Federal Patents to Mineral Estate and Valid State and Federal Mining Claims**
Some federal patents to mineral estate and/or valid state and federal mining claims exist in this district. Mining activity under the auspices of those patents and/or claims shall comply with relevant federal and state regulations.

(AO 2012-124(S), 2-26-13; AO 2013-117, 12-3-13; AO 2016-30, 3-22-16)

21.09.050 USE REGULATIONS

A. Table of Allowed Uses

Table 21.09-2 below lists the uses allowed within the base zoning districts in Girdwood. If a use is not defined in this chapter, the definition in chapter 21.05 shall apply. When the uses in a district are determined through a master planning process per subsections 21.09.030E. and F., this table shall not apply.

1. Explanation of Table Abbreviations

- a. **Permitted Uses**
“P” in a cell indicates the use is allowed by right in the respective zoning district. Permitted uses are subject to all other applicable regulations of title 21.
- b. **Administrative Site Plan Review**
“S” in a cell indicates the use requires administrative site plan review in the respective zoning district in accordance with the procedures of subsection 21.03.180B., *Administrative Site Plan Review*.
- c. **Major Site Plan Review**
“M” in a cell indicates the use requires major site plan review in the respective zoning district in accordance with the procedures of subsection 21.03.180C., *Major Site Plan Review*.
- d. **Conditional Uses**
“C” in a cell indicates, in the respective zoning district, the use is allowed only if reviewed and approved as a conditional use in accordance with the procedures of section 21.03.080, *Conditional Uses*. Throughout title 21, the term “conditionally allowed” means approval through the conditional use process is required.
- e. **Special Land Use Permit for Marijuana**
“T” in a cell indicates that the use requires a special land use permit for marijuana in accordance with the procedures of section 21.03.105.
- f. **O (with # inside)**
A circle with a number inside references uses with a different review and approval procedure, depending on the gross floor area of the building, or of the largest building in a multi-building development. The explanation of the sizes and associated review and approval procedures is located at the end of the table.
- g. **Prohibited Uses**
A blank cell indicates the use is prohibited in the respective zoning district.
- h. **Definitions and Use-Specific Standards**
Regardless of whether a use is allowed by right, subject to major or administrative site plan review, or permitted as a conditional use, there may be additional

standards applicable to the use. The existence of most use-specific standards is noted through a cross-reference in the last column of the table, but there may be other applicable non-referenced portions of municipal code as well. Cross-references include, but are not limited to, references to chapter 21.05, *Use Regulations*; chapter 21.03, *Review and Approval Procedures*; or section 21.09.050B., *Use-Specific Standards* for Girdwood. These standards shall apply in all districts unless otherwise specified.

2. Table Organization

In table 21.09-2, land uses and activities are classified into general “use categories” and specific “use types”, based on common functional, product, or physical characteristics, such as the type and amount of activity, the type of customers or residents, how goods or services are sold or delivered, and site conditions. This classification provides a systematic basis for assigning present and future land uses into appropriate zoning districts. This classification does not list every use or activity appropriate within the categories, and specific uses may be listed in one category when they may reasonably have been listed in one or more other categories. The use categories are intended merely as an indexing tool and are not regulatory.

3. Unlisted Uses

When application is made for a particular use category or use type not specifically listed in table 21.09-2, the procedure set forth in section 21.03.220, *Use Classification Requests*, shall be followed.

4. Use for Other Purposes Prohibited

Approval of a use listed in table 21.09-2, and compliance with the applicable use-specific standards for the use, authorizes the specific use only. Development or use of a property for any other use not specifically allowed in table 21.09-2 and approved under the appropriate process is prohibited.

5. Table of Allowed Uses

TABLE 21.09-2: TABLE OF ALLOWED USES

*P = Permitted; C = Conditional; S = Administrative Site Plan Review; M = Major Site Plan Review; O (with # inside) = see end of table
 For GIP, GCR-1, GCR-2, GCR-3, GDR, and GRR districts, see Section 21.09.040, Zoning Districts*

Use Category	Use Type	Residential						Commercial										Ind.		Resort		Other			Definitions and Use Specific Standards	
		gR 1	gR 2	gR 2A	gR 3	gR 4	gR 5	gC 1	gC 2	gC 3	gC 4	gC 5	gC 6	gC 7	gC 8	gC 9	gC 10	gl 1	gl 2	gR ST1	gR ST2	G A	G O S	G W		
RESIDENTIAL																										
Household Living	Dwelling, single-family detached	P	P	P	P	P	P				P	P	P	P							P	P				21.09.050B.2.d. 21.09.080C.
	Dwelling, single-family attached	S			S		S														P	P				21.09.050B.2.c 21.09.080D.
	Dwelling, two-family	P	P	P	P	P				P	P		P				P			P	P				21.09.050B.2.f. 21.09.080 D.	
	Dwelling, townhouse	S			S		S														P	P				21.09.050B.2.e. 21.09.080E.
	Dwelling, multiple-family (<4 dua)	P								P	P		P			P	P			P	P				21.09.050B.2.b. 21.09.080 E.	
	Dwelling, multiple-family (4-8 dua)	C				S	S			S	S	S	S			S	S			S	S				21.09.050B.2.b. 21.09.080 E.	
	Dwelling, multiple-family (>8-20 dua)					C	C			C		M	C			C	C			C	C				21.09.050B.2.b. 21.09.080 E.	
	Dwelling, multiple-family (>20 dua)																				C	C				21.09.050B.2.b. 21.09.080 E.
	Dwelling, mixed-use									P	P	P	P	P	P	P	P					P	P			
Group Living	Residential care facility, large	C				S	S			S	S	S	S			S	S									
	Residential care facility, small	P	P	P	P	P	P			P	P		P													
	Roominghouse	C				C	C			M	M	M	M			M	M			M	M				21.05.030B.4.	

TABLE 21.09-2: TABLE OF ALLOWED USES

*P = Permitted; C = Conditional; S = Administrative Site Plan Review; M = Major Site Plan Review; O (with # inside) = see end of table
 For GIP, GCR-1, GCR-2, GCR-3, GDR, and GRR districts, see Section 21.09.040, Zoning Districts*

Use Category	Use Type	Residential						Commercial										Ind.		Resort		Other			Definitions and Use Specific Standards	
		gR 1	gR 2	gR 2A	gR 3	gR 4	gR 5	gC 1	gC 2	gC 3	gC 4	gC 5	gC 6	gC 7	gC 8	gC 9	gC 10	gl 1	gl 2	gR ST1	gR ST2	G A	G O S	G W		
COMMUNITY																										
Adult Care	Adult care facility, 1-8 adults	P	P	P	P	P	P				P	P	P	P			P	P			P	P				21.05.040A.
	Adult care facility, 9+ adults	C					C				C	C	M	C			C	C			C	C				21.05.040A.
Child Care	Child care home, 1-8 children	P	P	P	P	P	P				P	P	P	P			P	P			P	P				21.05.040B.2.
	Child care facility, 9+ children	C					C				C	C	M	C			C	C			C	C				21.05.040B.1.
Community Buildings and Uses	All uses	M	M	M	M	M	M	M	M	M	M	M	M	M	M	M	M	M	M	M	M	M	M	M	M	21.09.050B.3.b
Community Service	Religious Assembly	S	S	S	S	S	S	S	S	S	S	S	S	S	S	S	S	S	S	S	S	S	S	S	S	21.05.040C.7.
	Cemetery	C	C	C	M	C	C	C	C	C	C	M	C	C	C	C	C	C	C	C	C	C	C	C	C	21.05.040C.1.
Cultural Facility	Botanical Gardens				S															S	S					
	Museum or cultural center							④	④	①	②	⑤	③	①	③	②	③			④	④				21.05.040D.4.	
	Visitor and information center							④	④	①	②	⑤	③	①	③	②	③			④	④		C		21.09.050B.3.e.	
Educational Facility	Boarding school	C			M						C	C	M	C		C	C	C							21.05.040E.1.	
	Private school	C			M						C	C	M	C			C	C			C	C			21.09.050B.3.d.	
	Vocational or trade school																	C				C			21.05.040E.6.	
Government Facility	Governmental Service							C									S	S			C					

TABLE 21.09-2: TABLE OF ALLOWED USES

*P = Permitted; C = Conditional; S = Administrative Site Plan Review; M = Major Site Plan Review; O (with # inside) = see end of table
 For GIP, GCR-1, GCR-2, GCR-3, GDR, and GRR districts, see Section 21.09.040, Zoning Districts*

Use Category	Use Type	Residential						Commercial										Ind.		Resort		Other			Definitions and Use Specific Standards
		gR 1	gR 2	gR 2A	gR 3	gR 4	gR 5	gC 1	gC 2	gC 3	gC 4	gC 5	gC 6	gC 7	gC 8	gC 9	gC 10	gl 1	gl 2	gR ST1	gR ST2	G A	G O S	G W	
	Police/fire station							P	P	P	P	P	P	P	P	P	P			P	P	C			
Health Care Facility	Health services								④	①	②	⑤	③	①	③	②	③			④	④				
Park and Open Area	Park, public	S	S	S	S	S	S	S	S	S	S	S	S	S	S	S	S			S	S	S	C	C	
	Passive and active recreation	P	P	P	P	P	P	P	P	P	P	P	P	P	P	P	P	P	P	P	P	P	P	C	
Transportation Facility	Airport																					C			
	Transit center							C				S	S		S	S			S	S					
	Heliport																			P	P				
	Railroad passenger terminal							C													C				
	Aircraft repair																						P		
	Aircraft storage hangar																						P		
	Aviation services																						P		Must be aviation related
Utility Facility	Utility facility																	P	P						
	Utility substation	C	C	C	M	C	C	C	C	C	C	M	C	C	C	C	C	P	P	C	C	C	C	C	
Communication Structures	Antenna only, large ¹							P	P	P	P	P	P	P	P	P	P	P	P	P	P	P			
	Antenna only, small ¹	P	P	P	P	P	P	P	P	P	P	P	P	P	P	P	P	P	P	P	P	P	P		
	Type 1 tower ¹							P	P	P	P	P	P	P	P	P	P	P	P				C	C	
	Type 2 tower ¹							P	P	P	P	P	P	P	P	P	P	P	P				C	C	

TABLE 21.09-2: TABLE OF ALLOWED USES

*P = Permitted; C = Conditional; S = Administrative Site Plan Review; M = Major Site Plan Review; O (with # inside) = see end of table
 For GIP, GCR-1, GCR-2, GCR-3, GDR, and GRR districts, see Section 21.09.040, Zoning Districts*

Use Category	Use Type	Residential					Commercial										Ind.		Resort		Other			Definitions and Use Specific Standards	
		gR 1	gR 2	gR 2A	gR 3	gR 4	gR 5	gC 1	gC 2	gC 3	gC 4	gC 5	gC 6	gC 7	gC 8	gC 9	gC 10	gl 1	gl 2	gR ST1	gR ST2	G A	G O S		G W
	Type 3 tower ¹						P	P	P	P	P	P	P	P	P	P	P	P	P				C	C	21.05.040K.
	Type 4 tower ¹						P	P	P	P	P	P	P	P	P	P	P	P	P				C	C	21.05.040K.
COMMERCIAL																									
Animal Sales, Service & Care	Animal grooming service							④	①	②	⑤	③	①	③	②										
	Animal boarding																P	P				P		21.05.050B.1.	
	Pet shop								①	②	⑤	③	①	③	②									21.05.050B.4.	
	Veterinary clinic						④	①	②	⑤	③	①	③	②	③									21.05.050B.5.	
Assembly	Club/lodge/meeting hall						④	①		⑤	③	①	③	②					④	④				21.09.050B.1.a	
Entertainment and Recreation	Amusement establishment						④	④	①		⑤	③	①	③	②				④	④				21.09.050B.1.a	
	Fitness and recreational sports center						④	④	①		⑤	③	①	③	②	③			④	④				21.05.050D.3.	
	Nightclub, licensed						④	④	①		⑤	③	①	③	②				④	④				21.09.050B.1.a	
	Theater company or dinner theater						④	④	①		⑤	③	①	③	②				④	④				21.05.050D.11. 21.05.020A.	
	Alpine ski facility																		C	C			C	21.09.050B.4.a.	
	Non-motorized general outdoor recreation, commercial											M							C	C					

TABLE 21.09-2: TABLE OF ALLOWED USES

*P = Permitted; C = Conditional; S = Administrative Site Plan Review; M = Major Site Plan Review; O (with # inside) = see end of table
 For GIP, GCR-1, GCR-2, GCR-3, GDR, and GRR districts, see Section 21.09.040, Zoning Districts*

Use Category	Use Type	Residential						Commercial										Ind.		Resort		Other			Definitions and Use Specific Standards
		gR 1	gR 2	gR 2A	gR 3	gR 4	gR 5	gC 1	gC 2	gC 3	gC 4	gC 5	gC 6	gC 7	gC 8	gC 9	gC 10	gl 1	gl 2	gR ST1	gR ST2	G A	G O S	G W	
	Golf driving range																				S				
Food and Beverage Service	Bar or tavern							④	④	①		⑤	③	①	③	②				④	④				21.09.050B.1.a
	Brew pub									①		⑤	③	①	③	②				④	④				21.09.050B.1.a
	Food and beverage kiosk							S	S	S		S	S												21.05.050E.2.
	Restaurant							④	④	①		⑤	③	①	③	②				④	④				21.09.050B.1.a
Office	Office, business or professional							④	④	①	②	⑤	③	①	③	②	③			④	④				21.05.050F.3.
	Broadcasting and recording facility								④	①	②	⑤	③	①	③	②									
	Financial institution							④	④	①		⑤	③	①	③	②				④	④				21.05.050F.2.
Retail (Personal Service)	Dry cleaning, drop-off site								④	①	②	⑤	③	①	③	②		P		④	④				
	General personal services							④	④	①	②	⑤	③	①	③	②				④	④				21.05.050G.3.
	Instructional services								④	①	②	⑤	③	①	③	②									21.05.040E.5.
Retail (Repair and Rental)	Small equipment rental							④	④	①	②	⑤	③	①	③	②		P		④	④				21.05.050G.4.
	Repair shop							④	④	①	②	⑤	③	①	③	②				④	④				
Retail (Sales)	Business service establishment							④	④	①	②	⑤	③	①	③	②				④	④				21.05.050G.1.

TABLE 21.09-2: TABLE OF ALLOWED USES

*P = Permitted; C = Conditional; S = Administrative Site Plan Review; M = Major Site Plan Review; O (with # inside) = see end of table
 For GIP, GCR-1, GCR-2, GCR-3, GDR, and GRR districts, see Section 21.09.040, Zoning Districts*

Use Category	Use Type	Residential					Commercial										Ind.		Resort		Other			Definitions and Use Specific Standards	
		gR 1	gR 2	gR 2A	gR 3	gR 4	gR 5	gC 1	gC 2	gC 3	gC 4	gC 5	gC 6	gC 7	gC 8	gC 9	gC 10	gl 1	gl 2	gR ST1	gR ST2	G A	G O S		G W
	Convenience store						④	④	①	②	⑤	③	①	③	②					④	④				21.05.050H.3. 21.05.020A.
	General retail						④	④	①	②	⑤	③	①	③	②					④	④				21.05.050H.7.
	Fueling station						C	C													S			21.05.050H.5.	
	Grocery or food store						④	④	①	②	⑤	③	①	③	②					④	④				21.05.050H.8.
	Liquor store							④			⑤	③	①	③	②					④	④				21.09.050B.1.a.
	Lumber yard/ building materials store							④	①		⑤	③	①	③	②			P							21.05.050H.2.
	Meat/seafood processing, storage, and sales																	P							
	Nursery, commercial										②	⑤	③												21.05.050A.1.
Vehicle and Equipment	Heavy equipment sales and rental																	P						21.05.060A.6.	
	Impound yard																	C						21.05.060D.2.	
	Parking lot or structure, private (10 or fewer spaces)						S	S	S		S	S		S	S					S	S	S			
	Parking lot or structure, private (11+ spaces)						M	M	M		M	M		M	M					M	M				
	Vehicle parts and supplies							④			⑤	③						P							21.05.050.1.4.

TABLE 21.09-2: TABLE OF ALLOWED USES

*P = Permitted; C = Conditional; S = Administrative Site Plan Review; M = Major Site Plan Review; O (with # inside) = see end of table
 For GIP, GCR-1, GCR-2, GCR-3, GDR, and GRR districts, see Section 21.09.040, Zoning Districts*

Use Category	Use Type	Residential						Commercial										Ind.		Resort		Other			Definitions and Use Specific Standards											
		gR 1	gR 2	gR 2A	gR 3	gR 4	gR 5	gC 1	gC 2	gC 3	gC 4	gC 5	gC 6	gC 7	gC 8	gC 9	gC 10	gl 1	gl 2	gR ST1	gR ST2	G A	G O S	G W												
	Vehicle-large, sales and rental																		P																	21.05.050I.5.
	Vehicle-small, sales and rental							P											P		④	④													21.05.050I.6.	
	Vehicle service and repair, minor							P	P										P																	21.05.050I.7.
	Vehicle storage yard																		P																	
Visitor Accommodations	Hostel (small)	M			M	M		M		M	M	M	M		M	M	M			M	M														21.09.050B.4.c.	
	Hostel (large)	C				C		C		M	C	M	M		M	M	C			M	M														21.09.050B.4.c.	
	Hotel/motel							C	C	C		M	C		C	C	C			C	C														21.09.050B.1.a	
	Inn	M			M			M		M	M	M	M	M	M	M	M			M	M														21.09.050B.4.d. 21.09.050B.1.a	
	Lodging Reservations/ Auto Rental Check-In							④	④	①	②	⑤	③	①	③	②	③			④	④															21.09.050B.4.e.
COMMERCIAL MARIJUANA USES																																				
	Marijuana cultivation facility																		T	T															21.05.055B.1. 21.03.105	
	Marijuana manufacturing facility																		T	T																21.05.055B.2. 21.03.105
	Marijuana testing facility													T	T			T	T																	21.05.055B.3. 21.03.105
	Marijuana retail sales establishment													T		T	T	T																		21.05.055B.4. 21.03.105

TABLE 21.09-2: TABLE OF ALLOWED USES

*P = Permitted; C = Conditional; S = Administrative Site Plan Review; M = Major Site Plan Review; O (with # inside) = see end of table
 For GIP, GCR-1, GCR-2, GCR-3, GDR, and GRR districts, see Section 21.09.040, Zoning Districts*

Use Category	Use Type	Residential						Commercial										Ind.		Resort		Other			Definitions and Use Specific Standards												
		gR 1	gR 2	gR 2A	gR 3	gR 4	gR 5	gC 1	gC 2	gC 3	gC 4	gC 5	gC 6	gC 7	gC 8	gC 9	gC 10	gl 1	gl 2	gR ST1	gR ST2	G A	G O S	G W													
	Storage yard																	P																			21.05.060D.5.
	Warehouse																	P																			
	Wholesale establishment																	P																			
Waste and Salvage	Composting facility																	C																		21.05.060E.1.	
	Snow disposal site					M												C	C												C					21.05.060E.6.	
	Solid waste transfer facility																	C																			21.05.060E.9.
<p>① Gross floor area; permit/review required: Permitted (P): < 2,000 sf Administrative Site Plan Review (S): 2,000-4,000 sf Major Site Plan Review (M): 4,001-6,500 sf Prohibited: > 6,500 sf</p> <p>② Gross floor area; permit/review required: Permitted (P): < 2,000 sf Administrative Site Plan Review (S): 2,000-4,000 sf Major Site Plan Review (M): 4,001-7,500 sf Prohibited: > 7,500 sf</p> <p>③ Gross floor area; permit/review required: Permitted (P): < 2,000 sf Administrative Site Plan Review (S): 2,000-4,000 sf Major Site Plan Review (M): 4,001-10,000 sf Prohibited: > 10,000 sf</p>																	<p>④ Gross floor area; permit/review required: Permitted (P): < 2,000 sf Administrative Site Plan Review (S): 2,000-4,000 sf Major Site Plan Review (M): 4,001-20,000 sf Prohibited: > 20,000 sf</p> <p>⑤ Gross floor area; permit/review required: Permitted (P): <2,000 sf Administrative Site Plan Review (S): 2,000-4,000 sf Major Site Plan Review (M): 4,001-30,000 sf Prohibited: > 30,000 sf</p> <p>(sf = square feet; dua = dwelling units per acre)</p>																				
<p>¹ In accordance with subsection 21.05.040K.3.g., a tower or antenna that is not permitted in a district may be requested through the conditional use process.</p>																																					

B. Use-Specific Definitions and Standards

The following use-specific standards apply regardless of whether the use type is permitted as a matter of right, subject to an administrative or major site plan review process, or subject to the conditional use process.

The use-specific standards of this section apply in place of any use-specific standards established in chapter 21.05, unless otherwise specified. If this section does not establish use standards for a certain use, then the use standards, including any generally applicable use standards, established in other sections of title 21 shall apply in Girdwood. Except where stated otherwise in this section 21.09.050, chapter 21.05 standards for accessory and temporary uses shall apply.

1. Generally Applicable Use-Specific Standards

a. *Uses Involving the Retail Sale of Alcoholic Beverages*

Any use that involves the retail sale of alcoholic beverages is subject to section 21.03.040, *Special Land Use Permit for Alcohol*. That process shall apply to any such use regardless of whether it is listed in table 21.09-2 as being permitted as a matter of right or subject to site plan review or the conditional use process. The applicant shall be required to obtain approval through both section 21.03.040, *Special Land Use Permit for Alcohol*, and the separate process referenced in table 21.09-2.

b. *Premises Containing Uses Where Children are Not Allowed*

Any premise containing uses where children are not allowed shall comply with subsection 21.05.020B.

2. Residential Uses

a. *Dwelling, Mixed Use*

i. *Definition*

A dwelling that is located on the same lot or in the same building as a non-residential use, in a single environment in which both residential and non-residential amenities are provided.

b. *Dwelling, Multi-Family*

i. *Definition*

A residential building or multiple residential buildings comprising three or more dwelling units on one lot. The definition includes the terms "apartment" or "apartment building."

ii. *Use-Specific Standards*

Children's play space: Multiple-family projects of more than ten dwelling units shall provide a play space of at least 1,000 square feet.

c. *Dwelling, Single-Family Attached*

i. *Definition*

One dwelling unit in a building on its own lot, with one wall abutting the wall of another single-family dwelling unit on an adjacent lot.

ii. *Use-Specific Standards (also applies to "Dwelling, Townhouse")*

(A) *Purpose*

The purpose of permitted attached single-family and townhouse dwelling unit projects is to preserve significant areas of natural landscape, or to prevent physical development of hazardous and wetlands areas unsuitable for development, by shifting the density allowed within an application area to a smaller development area within the application area.

(B) *Applicability*

The following standards shall apply to all attached single-family and townhouse development projects in Girdwood gR-1, gR-3, and gR-5 districts.

(C) *Development Standards*

- (1)** Site size: Two acres minimum.
- (2)** Site width: 150 feet minimum.
- (3)** Lot width for individual dwellings: 28 feet minimum.
- (4)** Residential density within development area: Eight dwelling units per acre maximum.
- (5)** Slopes within development area: 15 percent maximum.
- (6)** Building height: 35 feet maximum.
- (7)** Development area: 40 percent maximum (see subsection (D). below).
- (8)** Natural open space: 60 percent minimum.
- (9)** Parking requirements may be met on the lots and/or on common areas within the development area.
- (10)** Public sewers shall be available or provided for an attached single-family dwelling unit project.

(D) *Development Area*

A maximum of 40 percent of the area included in the proposed project may be developed. The development area includes all private lots, all portions of the common area developed with driveways, parking or other common facilities. The development area shall be located to retain a minimum thirty (30) foot wide section of natural open space around the perimeter, except as needed for public access to the development area.

(E) *Common Area*

A homeowners' association or other governance entity acceptable to the municipality shall be formed for the purpose of establishing covenants or restrictions, and providing joint responsibility for maintenance of the dwelling structures, and for maintenance and construction within common areas. Common area includes natural open space areas and all shared facilities within the development area, such as parking, storage, drives, trails, walks, play areas, and similar areas.

(F) *Natural Open Space Requirement*

A minimum of 60 percent of the area included in the proposed project shall be retained as natural open space, and no part shall have a dimension of less than 30 feet. The retained natural open space shall include a minimum 30 foot wide buffer, exclusive of utilities and utility easements, around the perimeter of the application area. A minimal number of common access driveways to the lots shall be permitted to cross the buffer, but the driveways shall be counted as part of the development area. Natural open

space used to meet minimum requirements shall be located only within common areas and shall not be located on private lots.

d. Dwelling, Single-Family Detached

i. Definition

One detached building on its own lot, erected on a permanent foundation, designed for long-term human habitation exclusively by one family, having complete living facilities, and constituting one dwelling unit.

e. Dwelling, Townhouse

i. Definition

A building containing more than two single-family dwelling units erected in a single row, on adjoining lots, with each unit having its own separate entrance.

ii. Use-Specific Standards

“Dwelling, Townhouse” must comply with the use-specific standards of “Dwelling, Single-Family Attached.”

f. Dwelling, Two-Family

i. Definition

One detached building on one lot designed for or occupied exclusively by two families and constituting two dwelling units. The definition includes the term “duplex.”

3. Community Uses

a. Active Outdoor Recreation

i. Definition

Those outdoor activities with minimal environmental impact, no motors, and use of trails. Activities using trails include dog sledding, Nordic skiing, and trail hiking. Horseback riding and/or mountain biking are only allowed on trails suitable for intensive use and designated for those types of activities. For activities using trails, motorized equipment or tools may be used for trail construction and maintenance.

b. Community Buildings and Uses

i. Definition

Structures and land uses owned, leased, or operated by a municipal or state agency to serve a public purpose, such as community centers, public schools (elementary, middle, and high), public parking lots, and offices, but excluding private schools, transportation, maintenance, police and fire stations, and utility facilities or substations.

ii. Use-Specific Standards

(A) Intent

Community buildings frequently used by the general public, such as a school or library, are community landmarks. It is intended for landmark public buildings to set a high architectural standard for the community.

(B) Development and Design Standards

Community buildings shall meet or exceed the site and building development design standards of sections 21.09.070 and 21.09.080 pertaining to commercial buildings.

c. **Passive Outdoor Recreation**

i. *Definition*

Those outdoor activities with low environmental impact, are not intrusive, do not use motors and may not require trails. Activities not necessarily requiring trails include backcountry skiing, dog sledding, snowshoeing, off trail hiking, paragliding, blueberry picking, birding, and picnicking. This definition does not include activities involving vehicles or games such as paint ball.

d. **Private School**

i. *Definition*

Any building or group of buildings used for academic education for students between the kindergarten and 12th grade level, without major funding from any government agency.

e. **Visitor and Information Center**

i. *Definition*

A facility providing information, interpretation, and educational services for visitors.

4. **Commercial Uses**

a. **Alpine Ski Facility**

i. *Definition*

A facility and related terrain utilized for alpine skiing and uses and facilities typically associated with the use and operation of such facility including, but not limited to:

- i. Ski and snowboard runs and trails;
- ii. Ski lifts and tows, including towers and structures, related to skiing and snowboarding patrons;
- iii. Snow making equipment/facilities;
- iv. Ski patrol facilities;
- v. Ski area administrative and ticketing offices;
- vi. Special events directly associated with ski areas, such as ski races, snowboard races, snowmachine races, bicycle races, and concerts;
- vii. Alpine slide;
- viii. Nordic ski trails and facilities;
- ix. Tubing hills;
- x. Ski and equipment rental facilities and ski instruction facilities;
- xi. Ice skating rinks;
- xii. Ski bridges; and
- xiii. Supporting accessory structures.

Alpine Ski Facility shall not include uses such as lodges, hotels, dwelling units, restaurants, retail shops, outdoor carts and vending areas, clinics, day care centers, offices, or high impact recreational uses such as go

carts, golf courses and driving ranges, paint ball games, rifle ranges, waterslides, and stables.

b. Camper Park—Girdwood Only

i. Definition

A lot or parcel of land, or portion thereof, temporarily occupied or intended for temporary occupancy by recreational vehicles for travel, recreational, or vacation usage for short periods of stay. These establishments may provide laundry rooms, recreation halls, and playgrounds. These uses shall not include vehicle storage.

ii. Use-Specific Standards

(A) Interior Roads

One-way roads shall be at least 15 feet wide. Two-way roads shall be at least 20 feet wide. The turning radius in loops and turns shall be at least 30 feet.

(B) Length of Stay

The occupants of space shall remain in the camper park a period a maximum of 30 days.

(C) Amenities

(1) Toilet facilities shall be provided as follows: A minimum of one restroom/outhouse per 12 campsites. Each restroom/outhouse facility shall contain at least two toilets, separated for each sex.

(2) A water outlet shall be provided in conjunction with each toilet facility. All water taps or outlets serving campsites shall be of a type compatible with garden hose connections.

(3) One trash receptacle shall be provided for every four campsites. The receptacles shall be bear-proof.

(D) Campsite Specifications

(1) Each recreational vehicle campsite shall contain a minimum of 2,000 square feet.

(2) No campsite shall have direct vehicular access to a public road.

(3) There shall be a vegetated buffer of at least 15 feet between each campsite.

(4) Each campsite shall contain at least one reinforced surface parking space, level from side to side and with sufficient crown to provide adequate drainage. The dimensions of the parking space shall be at least ten feet wide by 40 feet long.

(5) Each campsite shall have a picnic table.

c. Hostel

i. Definition

An overnight lodging facility containing between six and 19 guest rooms or up to 60 pillows. Sleeping accommodations may be dormitory-style and shared kitchen facilities may be available to the guests. A **Small Hostel**

contains between six and ten guestrooms and up to 30 pillows. A **Large Hostel** contains between 11 and 19 guestrooms and up to 60 pillows.

d. Inn

i. Definition

A building or group of buildings containing between six and 19 guest rooms or up to 60 pillows for overnight lodging for compensation, where at least one meal per day is provided to guests, there is a central meeting room or lounge available to all guests, and there are no shared kitchen facilities.

e. Lodging Reservations/Auto Rental Check-In

i. Definition

An office where lodging reservations may be made or where a person may check-in and pay for lodging when the lodging is not on site, or an office where an auto may be rented, when the auto is not stored on site.

f. Tent Campground

i. Definition

A lot or parcel of land occupied or intended for temporary occupancy by tents only for travel, recreational, or vacation usage for short periods of stay. A potable water source is not required. No recreational vehicles are allowed.

ii. Location

Tent campgrounds are a conditional use only in the GCR-3 and GIP districts.

iii. Use Specific Standards

(A) Each tent site shall contain a minimum of 800 square feet, with no dimension less than 20 feet.

(B) To maintain an aesthetic camping atmosphere, density shall not exceed 20 sites per acre.

(C) Each tent site shall contain at least one automobile parking space; the dimensions shall be at least ten feet wide by 20 feet long.

(D) There shall be a vegetated buffer of at least 15 feet between each tent site.

(E) Each tent site shall have a picnic table.

(F) Toilet facilities shall be provided as follows: A minimum of one restroom/outhouse per 12 campsites. Each restroom/outhouse facility shall contain at least two toilets, separated for each sex.

(G) One trash receptacle shall be provided for every six campsites. The receptacles shall be bear-proof.

5. Industrial Uses

a. Cottage Crafts

i. Definition

An establishment engaged in small-scale assembly and arts-and-crafts production by hand manufacturing, involving the use of hand tools and small-scale equipment. Examples include, but are not limited to, candle making, artisan woodworking, art studio/gallery, artisan pottery and jewelry production, and similar establishments. Cottage crafts are less

intensive, and do not have the off-site impacts often associated with general industrial uses.

ii. *Use-Specific Standards*

(A) *Production and Sale of Cottage Crafts*

Cottage crafts shall only be produced within a wholly-enclosed permanent structure. Cottage craft production may occupy up to 1,500 square feet of gross building area, and an additional 150 square feet minimum gross building area on the same lot shall be devoted to the display and retail sale of the crafts produced. The retail/display area shall be located on the ground floor and in the front part of the building facing the primary street on where the lot is located.

(B) *Prohibitions*

The outdoor storage of materials related to the production and sale of cottage crafts is prohibited. The use of equipment, materials, or processes creating hazards, noise, vibration, glare, fumes, or odors detectable to the normal senses off-site is prohibited.

b. *Land Reclamation*

i. *Definition*

An operation engaged primarily in increasing land-use capability by changing the land's character or environment through fill or regrading. Land reclamation shall only include operations of more than one year, at a scale involving 5,000 cubic yards or more of fill material. Site preparation as part of the development of a subdivision under a subdivision agreement is not included in this definition. Reclamation plans that may be required for other activities, such as mining, are not included in this definition.

c. *Natural Resource Extraction, Inorganic and/or Organic*

i. *Definition*

The development or extraction of organic and/or inorganic material from its natural occurrences on affected land. This use includes placer mining operations where rock byproduct is removed from the premises. This shall also include commercial or industrial operations involving removal of timber, native vegetation, peat, muck, topsoil, fill, sand, gravel or rock, or any other mineral and other operations with similar characteristics. This use includes only multi-year operations of a scale involving 50,000 cubic yards or more of fill material. Site preparation as part of the development of a subdivision under a subdivision agreement is not included in this definition. Mining activity under the auspices of federal patents to mineral estate and/or valid state and federal mining claims is not included in this definition.

C. **Accessory Uses**

1. **Table of Allowed Accessory Uses**

Table 21.09-3 below lists the accessory uses allowed within all base zoning districts.

a. ***Explanation of Table Abbreviations***

i. *Permitted Uses*

"P" in a cell indicates the accessory use is allowed by right in the respective zoning district. Permitted uses are subject to all other applicable regulations of title 21.

- ii. *Administrative Site Plan Review*
“S” in a cell indicates the accessory use requires administrative site plan review in the respective zoning district in accordance with the procedures of subsection 21.03.180B., *Administrative Site Plan Review*.
- iii. *Major Site Plan Review*
“M” in a cell indicates the use requires major site plan review in the respective zoning district. Until the provisions for major site plan review are adopted, an “M” in a cell indicates that the use is allowed only if reviewed and approved as a conditional use in accordance with the procedures of subsection 21.03.180C., *Major Site Plan Review*.
- iv. *Conditional Use*
“C” in a cell indicates, in the respective zoning district, the use is allowed only if reviewed and approved as a conditional use in accordance with the procedures of section 21.03.080, *Conditional Uses*.
- v. *Prohibited Uses*
A blank cell indicates the accessory use is prohibited in the respective zoning district.
- vi. *Definitions and Use-Specific Standards*
Regardless of whether an accessory use is allowed by right or subject to administrative site plan review, additional standards may be applicable to the use. The existence of use-specific standards is noted through a section reference in the last column of the table.
- vii. *Unlisted Accessory Uses or Structures*
An accessory use or structure not listed in table 21.09-3 may be permitted, subject to compliance with all applicable regulations of this title.

b. **Table of Allowed Accessory Uses**

TABLE 21.09-3: TABLE OF ACCESSORY USES																								
<i>P = Permitted; S = Administrative Site Plan Review; M = Major Site Plan Review; C = Conditional Use For GIP, GCR-1, GCR-2, GCR-3, GDR, and GRR districts, see Section 21.09.040, Zoning Districts</i>																								
Accessory Uses	Residential						Commercial										Ind.		Resort		Other			Definitions and Use Specific Standards
	gR1	gR2	gR2A	gR3	gR4	gR5	gC1	gC2	gC3	gC4	gC5	gC6	gC7	gC8	gC9	gC10	gl1	gl2	gRS T1	gRS T2	GA	GOS	GW	
Accessory dwelling unit (ADU)	P	P	P	P	P				P	P		P							P	P				21.05.070D.1 21.09.050C.2.a
Bed and breakfast (up to 3 guestrooms)	P	P	P	P	P				S	S		S				S								21.05.070D.2.
Bed and breakfast (4 or 5 guestrooms)	M	M	M	M	M				S	S		S												21.05.070D.2
Beekeeping	P	P	P	P	P																			21.05.070D.3.
Dormitory																		P	C	C				21.05.070D.5.
Drive-through service							C	C			C													21.09.050C.2.b
Garage or carport, private residential	P	P	P	P	P	P			P	P	P	P	P	P	P	P			P	P				21.05.070D.8.
Home- and garden-related use	P	P	P	P	P	P			P	P	P	P	P	P	P	P			P	P				21.05.070D.9.
Home occupation	P	P	P	P	P	P			P	P	P	P	P	P	P	P			P	P				21.05.070D.12.
Marijuana, personal cultivation	P	P	P	P	P	P			P	P	P	P	P	P	P	P			P	P				21.05.070D.13.
Outdoor keeping of household pets	P	P	P	P	P	P			P	P		P												
Paddock, stable or barn			P									P												
Private storage of non-commercial equipment	P	P	P	P	P	P			P	P	P	P												21.09.050C.2.c.
Telecommunications antenna only, large	P ¹	P ¹	P ¹	P ¹	P ¹	P ¹													P ¹	P ¹				21.05.040K.
Telecommunications antenna only, small	P	P	P	P	P	P													P	P				21.05.040K.
Type 4 tower	S ²	S ²	S ²	S ²	S ²	S ²													S ²	S ²				21.05.040K.

TABLE 21.09-3: TABLE OF ACCESSORY USES

*P = Permitted; S = Administrative Site Plan Review; M = Major Site Plan Review; C = Conditional Use
 For GIP, GCR-1, GCR-2, GCR-3, GDR, and GRR districts, see Section 21.09.040, Zoning Districts*

Accessory Uses	Residential						Commercial										Ind.		Resort		Other			Definitions and Use Specific Standards
	gR1	gR2	gR2A	gR3	gR4	gR5	gC1	gC2	gC3	gC4	gC5	gC6	gC7	gC8	gC9	gC10	gI1	gI2	gRS T1	gRS T2	GA	GOS	GW	
Vehicle repair/rebuilding, outdoor, hobby			P																					21.05.070D.18.
<p>¹ The telecommunications antenna is allowed only when meeting the concealment standards of 21.05.040K.8.d. and as accessory to a multifamily structure containing at least seven dwelling units or a nonresidential use.</p> <p>² The tower is allowed only as accessory to a multifamily structure containing at least seven dwelling units, or to a nonresidential use.</p>																								

2. Use-Specific Standards for Accessory Uses

a. Accessory Dwelling Units

Except as set forth below, the generally applicable Accessory Dwelling Unit regulations contained in subsection 21.05.070D.1., *Accessory dwelling units (ADUs)* shall apply. The regulations set forth below shall apply in addition to those contained in subsection 21.05.070D.1. except, in case of conflict, the regulations below shall govern.

i. Maximum Number of Accessory Units

Except as provided in subsection ii., below, only one accessory dwelling unit or bed and breakfast unit, as defined in section 21.05.070D., shall be allowed on any single-family residential lot. The accessory dwelling unit may be a rental unit.

ii. Accessory Dwelling Unit as Bed and Breakfast

The accessory dwelling unit may be used as a bed and breakfast room, but the bed and breakfast facility is then limited to only one guestroom, the accessory dwelling unit.

iii. Location

An accessory dwelling unit shall be on the same lot as the primary dwelling unit. An accessory dwelling unit shall be attached to the single-family dwelling unit; if the lot is at least 16,800 sq. ft., the accessory dwelling unit may be detached from the primary dwelling unit.

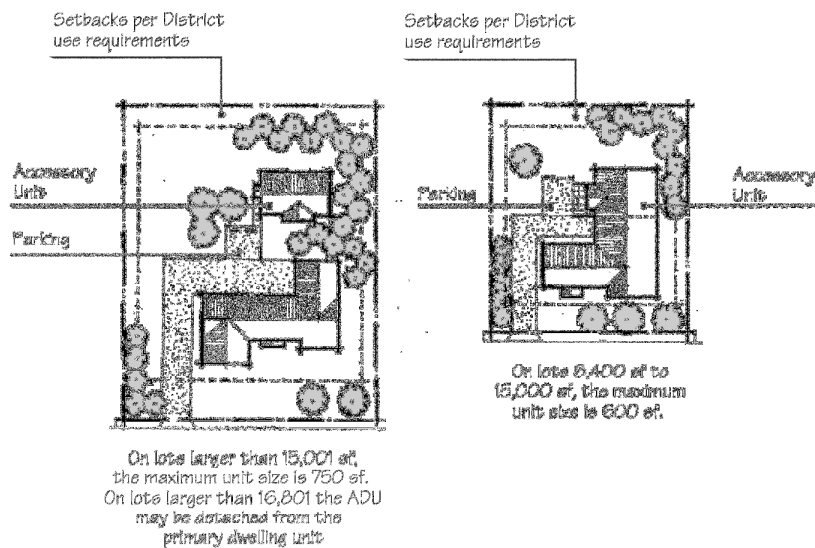

Accessory Dwelling Unit

iv. Maximum Square Footage

The minimum square footage for an accessory dwelling unit is 300 sq. ft. The maximum square footage for an accessory dwelling unit is 600 sq. ft., on a lot up to and including 15,000 sq. ft. and 750 sq. ft., on a lot over 15,000 sq. ft.; provided, however, that in the gRST-1 and gRST-2 districts, the maximum square footage for an accessory dwelling unit is 750 square feet on a single-family residential lot. The accessory dwelling unit shall not, however, exceed 50 percent of the gross floor area of the primary dwelling unit.

- v. ***Floor Area Ratio; Density***
The floor area of the accessory dwelling unit is included, along with the floor area of the primary dwelling unit, in calculating the floor area ratio on the lot, but the accessory dwelling unit is not included in calculating the average density for a new single-family subdivision.
 - vi. ***Parking***
In addition to the parking requirements for the primary dwelling unit, one off-street parking space shall be provided for each accessory dwelling unit of 600 sq. ft. or less, and two off-street parking spaces shall be provided for an accessory dwelling unit larger than 600 sq. ft.
 - vii. ***Owner Occupancy***
Either the principal dwelling or the accessory unit on any site shall be occupied by the owner of the principal dwelling or owner of the lot where the accessory unit is located.
 - viii. ***Architectural Compatibility***
An accessory dwelling unit, whether attached to or detached from the primary dwelling unit, shall be compatible in style and materials with the primary dwelling unit.
 - ix. ***New Accessory Dwelling Unit Where Single-Family Dwelling Unit Already in Existence***
A new accessory dwelling unit to be constructed on a lot with an existing single-family dwelling unit shall conform to all development and dimensional standards in the applicable zone district regulations.
- b. ***Drive-Through Service***
 - i. ***Definition***
The physical facilities of an establishment that encourage or permit customers to receive services, obtain goods, or be entertained while remaining in their motor vehicles.
 - ii. ***Use-Specific Standards***
Restaurants with drive-through service are only permitted in the gC-2 district.
 - c. ***Private Outdoor Storage of Non-Commercial Equipment***
 - i. ***Definition***
The private storage of non-commercial equipment, including non-commercial trucks, recreational vehicles, boats, aircraft, off-road vehicles, or travel trailers.

3. Prohibited Accessory Uses and Structures

Connex trailers, railroad box cars, and the like are prohibited in residential districts.

D. Definitions

The following words, terms, and phrases, when used in this chapter, shall have the meanings ascribed to them in this section, except where the context clearly indicates a different meaning:

- 1. **Building Envelope:** The developable space within any lot defined by the setbacks.
- 2. **Channel Sign:** A sign consisting of letters, symbols, or other shapes, where only such letters, symbols, or other shapes are illuminated.

3. **Commercial Vehicle:** A vehicle with a Gross Vehicle Weight Rating (GVWR) of 11,000 pounds or more.
4. **Floor Area Ratio (FAR):** The maximum gross floor area of all buildings on a lot or parcel, divided by the area of the lot or parcel.

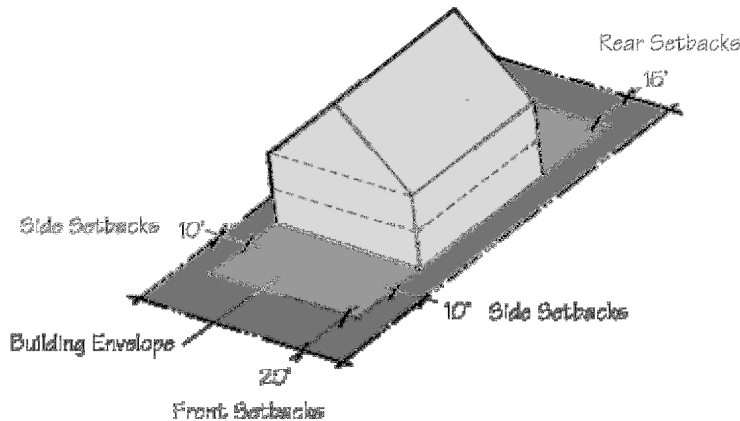

Floor Area Ratio (FAR) Example

Lot Size: 10,400 square feet

FAR: 0.5

Maximum Gross Building Area:
5,200 square feet

Illustration assumes no useable space under the eaves (in the attic).

5. **Permeable Surface:** An area of ground, by reason of its physical characteristics and the characteristics of materials covering it, able to absorb rain or surface water at a rate equal or greater than lawn turf. Examples include natural vegetation, lawn turf, landscape beds, gardens, mulch, decorative gravel, and some types of porous pavements.
6. **Pillow:** A sleeping accommodation for one person.
7. **Sight Distance Triangle:** The roadway area visible to the driver; the required length is the distance necessary to allow safe vehicular egress from a street, driveway, or alley to a major street. The criteria for determining required sight distance is set forth below.

The sight distance triangle is shown below and described as follows:

- Point A is located on the minor approach 15 feet from the edge of a major road travelway.
- Point B₁ is located in the center of lane 1.
- Point B₂ is located in the center of lane 2.
- Points C₁ and C₂ are located based on the design speed of the major road.
- Point A is connected to points C₁ and C₂ by straight lines.

Design Speed	Sight Distance
60 mph	650 ft.
50 mph	515 ft.
40 mph	415 ft.
30 mph	310 ft.
20 mph	210 ft.

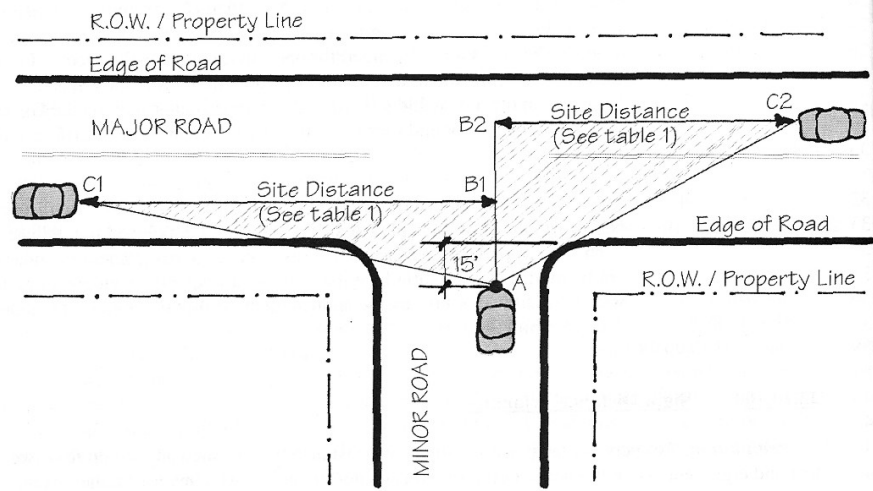

Sight Distance Triangle

8. **Sno-Cat Skiing:** Skiing in remote areas where access is provided by sno-cats or similar vehicles.
9. **Storage:** Items placed in substantially the same location for more than ten days.
10. **Tree:** A woody perennial plant with a single main stem. In Girdwood, a large tree is 18 inches in diameter or more at breast height (DBH).
11. **Tree Canopy:** The area, in square feet, of a tree's spread. Existing tree canopy is determined by measuring the ground's surface area covered by the branch spread of a single tree or clump or grove of trees.

(AO 2012-124(S), 2-26-13; AO 2013-117, 12-3-13; AO 2014-133, 11-5-14; AO 2015-142(S-1), 6-21-16; AO 2016-3(S), 2-23-16; AO 2016-30, 3-22-16; AO 2017-68, 4-24-2017)

21.09.060 DIMENSIONAL STANDARDS

A. Applicability

All structures that legally exist on January 1, 2014 shall be considered conforming with respect to setbacks. Any additions to the footprint of those structures, including but not limited to cantilevers, decks over 30 inches, and overhangs, shall conform to this title.

B. Dimensional Standards Tables

All primary and accessory structures are subject to the dimensional standards set forth in the following tables. Bracketed numbers refer to additional specific standards at the bottom of each table. These general standards may be further limited or modified by other applicable sections of title 21.

1. Table of Dimensional Standards: Residential Districts

TABLE 21.09-5: TABLE OF DIMENSIONAL STANDARDS GIRDWOOD RESIDENTIAL DISTRICTS								
Uses	Lot Dimensions		Minimum Setbacks			Building Bulk and Height		
	Min Area (sq ft)	Min. Width	Front	Side	Rear	Max Height	Max Lot Coverage (%)	Max Floor Area Ratio
gR-1: Alyeska Highway mixed residential district								
Dwelling, multi-family	19,800 for 3 units, add 4,000 for each additional unit	70 feet	20 feet ¹	10 feet ²	15 feet; or 20 feet for lots > 1 acre ²	35 feet	25% for lots larger than 15,000 sq ft; 30% otherwise	0.45 for lots > 12,500 sq. ft., or 6,250 sq. ft., whichever is greater 0.50 for lots ≤ 12,500 sq ft
Dwelling, single-family attached	See 21.09.050B.2.c.							
Dwelling, single-family detached	10,400	70 feet	20 feet ¹	10 feet ²	15 feet; or 20 feet for lots > 1 acre [2]	35 feet	25% for lots larger than 15,000 sq ft; 30% otherwise	0.45 for lots > 12,500 sq. ft., or 6,250 sq. ft., whichever is greater 0.50 for lots ≤ 12,500 sq ft
Dwelling, townhouse	See 21.09.050B.2.c.							
Dwelling, two-family	16,800	70 feet	20 feet ¹	10 feet ²	15 feet; or 20 feet for lots > 1 acre [2]	35 feet	25% for lots larger than 15,500 sq ft; 30% otherwise	0.45 for lots > 12,500 sq. ft., or 6,250 sq. ft., whichever is greater 0.50 for lots ≤ 12,500 sq ft
Roominghouse	19,800	70 feet	20 feet ¹	10 feet	15 feet; or 20 feet for lots > 1 acre	35 feet	25% for lots larger than 15,000 sq ft; 30% otherwise	0.45 for lots > 12,500 sq. ft., or 6,250 sq. ft., whichever is greater 0.50 for lots ≤ 12,500 sq ft
Community buildings and uses	10,400							
Religious assembly	20,800							
Hostel or inn	1.5 acres							
All other allowed uses	10,400							
gR-2: Single-family/two-family residential district								
gR-2A: Single-family/two-family residential district (Crow Creek Road)								
Dwelling, single-family detached	10,400; or 50,000 without sewer	70 feet; 100 feet without sewer	20 feet ¹	10 feet ²	15 feet; or 20 feet for lots > 1 acre [2]	35 feet	25% for lots larger than 15,000 sq ft; 30% otherwise	0.45 for lots > 12,500 sq. ft., or 6,250 sq. ft., whichever is greater 0.50 for lots ≤ 12,500 sq ft
Dwelling, two-family	16,800; or 50,000 without sewer							
Community buildings and uses	10,400	70 feet; 100 feet without sewer	20 feet ¹	10 feet	15 feet; or 20 feet for lots > 1 acre	35 feet	25% for lots larger than 15,000 sq ft; 30% otherwise	0.45 for lots > 12,500 sq. ft., or 6,250 sq. ft., whichever is greater
Religious assembly	20,800							

TABLE 21.09-5: TABLE OF DIMENSIONAL STANDARDS GIRDWOOD RESIDENTIAL DISTRICTS								
Uses	Lot Dimensions		Minimum Setbacks			Building Bulk and Height		
	Min Area (sq ft)	Min. Width	Front	Side	Rear	Max Height	Max Lot Coverage (%)	Max Floor Area Ratio
All other allowed uses	10,400							0.50 for lots ≤ 12,500 sq ft
gR-3: Single-family/two-family residential district								
Dwelling, single-family attached	See 21.09.050B.2.c.							
Dwelling, single-family detached	8,400; or 50,000 without sewer	70 feet; 100 feet without sewer	(same as "Dwelling, two-family" below)			35 feet	25% for lots larger than 15,000 sq ft; 30% otherwise	0.45 for lots > 12,500 sq. ft., or 6,250 sq. ft., whichever is greater 0.50 for lots ≤ 12,500 sq ft
Dwelling, townhouse	See 21.09.050B.2.c.							
Dwelling, two-family	16,800; or 50,000 without sewer	70 feet; 100 feet without sewer	For lots ≤ 21,780 sq ft: front: 20 feet side: 10 feet rear: 15 feet			35 feet	25% for lots larger than 15,000 sq ft; 30% otherwise	0.45 for lots > 12,500 sq. ft., or 6,250 sq. ft., whichever is greater 0.50 for lots ≤ 12,500 sq ft
Community buildings and uses, except educational facilities	8,400; or 50,000 without sewer		For lots 21,781-43,560 sq ft: front: 25 feet side: 15 feet rear: 20 feet					
Religious assembly	20,800		For lots > 43,560 sq ft: front: 30 feet side: 20 feet rear: 30 feet					
Private schools	16,800							
Inn	1.5 acres; or 5 acres without sewer							
All other allowed uses	8,400; or 50,000 without sewer							
gR-4: Multi-family residential district								
Dwelling, multi-family	12,500	70 feet	20 feet ¹	10 feet ²	10 feet ²	35 feet	40%	n/a
Roominghouse	10,400	70 feet	20 feet ¹	10 feet	10 feet	35 feet	40%	n/a
Community buildings and uses	10,400							
Religious assembly	20,800							
All other allowed uses	10,400							
gR-5: Multi-family residential district								
Dwelling, multi-family	20,000	100 feet	25 feet	15 feet	20 feet	35 feet	40%	n/a
Dwelling, single-family attached	See 21.09.050B.2.c.							
Dwelling, single-family detached ³	50,000	100 feet	25 feet	15 feet	20 feet	35 feet	40%	n/a

TABLE 21.09-5: TABLE OF DIMENSIONAL STANDARDS GIRDWOOD RESIDENTIAL DISTRICTS								
Uses	Lot Dimensions		Minimum Setbacks			Building Bulk and Height		
	Min Area (sq ft)	Min. Width	Front	Side	Rear	Max Height	Max Lot Coverage (%)	Max Floor Area Ratio
Dwelling, townhouse	See 21.09.050B.2.c.							
Religious assembly	20,800	80 feet	25 feet	15 feet	20 feet	35 feet	40%	n/a
All other allowed uses	10,400							

ADDITIONAL SPECIFIC STANDARDS:

¹ Alyeska Highway Setbacks: Minimum setback of 25 feet is required from any property line abutting the Alyeska Highway, but if the property extends into the road, the 25 foot setback shall be measure from the edge of the road easement.

² Side and rear setback flexibility: Side setbacks may be reduced by five feet on one side of the lot, but the amount of setback reduction shall be added to the opposite side setback. Rear setbacks may be reduced by five feet, but the amount of reduction shall be added to the front setback.

³ Single-family dwellings in gR-5: Single-family detached dwellings in the gR-5 are subject to the provisions of 21.09.040B.f.iii.(B).

2. Table of Dimensional Standards: Commercial Districts

TABLE 21.09-6: TABLE OF DIMENSIONAL STANDARDS GIRDWOOD COMMERCIAL DISTRICTS								
Uses	Lot Dimensions		Minimum Setbacks (ft)			Bulk, Height and Density		
	Min Area (Sq Ft)	Min. Width	Front	Side	Rear	Max. Height	Max. Lot Coverage	Max Dwelling Units / Acre
gC-1: Seward Highway/West Alyeska Highway Commercial District								
All uses	6,000	50 ft	20 ⁵	20 ⁶	20	2 stories not to exceed 35 ft	70%	n/a
gC-2: Girdwood Station/Seward Highway Commercial District								
All uses	6,000	50 ft	13 ⁵	10 ⁶	20 ⁷	2 stories not to exceed 35 ft	70%	n/a
gC-3: Old Townsite Commercial/Residential District								
All uses	6,000	50 ft	13 ⁵	10 ⁶	10 ⁷	4	2,500 square feet or 50%, whichever is greater	n/a
gC-4: Lower Alyeska Highway Commercial District								
All uses, ≤ 21,780 Sq Ft	10,400	80 ft	25 ⁵	10 ⁶	15 if lot size < 1 acre; 20 if lot size is ≥ 1 acre	35 ft	40%	20
All uses, > 21,781 Sq Ft				10 ⁶				

TABLE 21.09-6: TABLE OF DIMENSIONAL STANDARDS GIRDWOOD COMMERCIAL DISTRICTS								
Uses	Lot Dimensions		Minimum Setbacks (ft)			Bulk, Height and Density		
	Min Area (Sq Ft)	Min. Width	Front	Side	Rear	Max. Height	Max. Lot Coverage	Max Dwelling Units / Acre
gC-5: New Townsite South Commercial District								
All uses, ≤ 21,780 Sq Ft	8,400	80 ft	16 ⁵	10 ⁶	20	35 ft	50%	20
All uses, 21,781 Sq Ft – 5 acres			16 ⁵	20 ⁶	25			
All uses, > 5 acres			16	30 ⁶	30			
gC-6: Crow Creek Road Commercial/Residential District								
All uses	8,400; or 50,000 without sewer	70 ft	18	10; or 15 if lot size > 21,781 sq ft ⁶	15	35 ft	40%	20
gC-7: Townsite Square Commercial District								
All uses	6,000	50 ft	16 min; 20 max ⁸	Zero setback permitted on one side [3] and in accordance with 21.09.040C. 2.g.iii.(D). if applicable; otherwise 10	15	4	70%	20
gC-8: New Townsite North Commercial District								
All uses	6,000	50 ft	16 min; 20 max ⁸	10 ⁶	10	35 ft	60%	20
gC-9: East Hightower Commercial/Residential District								
All uses	6,000	50 ft	16 min; 20 max ⁸	10 ⁶	10	35 ft	60%	20
gC-10: Upper Alyeska Highway Commercial District								
All uses, ≤ 21,780 Sq Ft	8,400	60 ft	20 ⁵	15 ⁶	20	35 ft	70%	20
All uses, 21,781 Sq Ft – 5 acres			20 ⁵	20 ⁶	20			
All uses, > 5 acres			30 ⁵	30 ⁶	30			

**TABLE 21.09-6: TABLE OF DIMENSIONAL STANDARDS
 GIRDWOOD COMMERCIAL DISTRICTS**

Uses	Lot Dimensions		Minimum Setbacks (ft)			Bulk, Height and Density		
	Min Area (Sq Ft)	Min. Width	Front	Side	Rear	Max. Height	Max. Lot Coverage	Max Dwelling Units / Acre

ADDITIONAL SPECIFIC STANDARDS:

⁴ For structures with only commercial uses: Two stories not to exceed 35 feet.

For structures with only residential uses: 35 feet.

For structures with commercial uses on the ground level and residential uses above: second story may include loft space not a separate dwelling unit and maximum height is 35 feet.

⁵ Alyeska Highway Setbacks - Minimum setback of 25 feet is required from any property line abutting the Alyeska Highway, but if the property extends into the road, the 25 foot setback shall be measured from the edge of the road easement.

⁶ Zero Lot Line Setbacks - Where adjoining property owners agree to connect buildings or cooperate in the design of a public passageway or courtyard between them, a zero lot line side set-back is allowed on one side.

⁷ Alley Exemption - Where a platted alley right-of-way abuts a parcel, there shall be no required setback along the property line.

⁸ Maximum Front Setback Exception - Limited portions of building frontage may, subject to administrative site plan review, be allowed to step back further than the maximum allowed front setback to create small usable public spaces in the front of a building.

3. Table of Dimensional Standards: Industrial Districts

**TABLE 21.09-7: TABLE OF DIMENSIONAL STANDARDS
 GIRDWOOD INDUSTRIAL DISTRICTS**

Use	Lot Dimensions		Minimum Setbacks (ft)			Building Bulk and Height	
	Min Area (Sq Ft)	Min. Width	Front	Side	Rear	Maximum Lot Coverage	Maximum Height
gl-1: Ruane Road Industrial District⁹							
All uses, ≤ 1 acre	10,400	80 ft	20	10	10	Unrestricted	25 feet
All uses, > 1 acre			25	15	15		
gl-2: Upper Crow Creek Industrial District⁹							
All uses	50,000	150 ft	25	15	15	Unrestricted	35 feet

ADDITIONAL SPECIFIC STANDARDS:

⁹ Minimum setback along any property line contiguous with the GOS district is 20 feet for lots less than or equal to one acre in gl-1 and 30 feet for all other lots in gl-1 and gl-2 districts.

4. Table of Dimensional Standards: Resort Districts

TABLE 21.09-8: TABLE OF DIMENSIONAL STANDARDS GIRDWOOD RESORT DISTRICTS								
Use	Lot Dimensions		Minimum Setbacks			Building Bulk and Height		
	Min Area (Sq Ft)	Min. Width	Front	Side	Rear	Max. Height	Max. Lot Coverage	Maximum Floor Area Ratio
gRST-1: Original Mountain Base Resort District								
All uses	8,400	60 feet	13 feet ¹⁰	10 feet; or 20 feet if lot size > 0.5 acre ¹¹	20 feet	40 feet	50%	0.7 ¹²
gRST-2: New Base Resort District								
All uses	8,400	80 feet	13 feet ¹⁰	10 feet; or 20 feet if lot size > 0.5 acre ¹¹	20 feet	75 feet	50%	0.7 ¹²
ADDITIONAL SPECIFIC STANDARDS:								
¹⁰ <u>Arlberg Road Setbacks</u> - The minimum setback along any property line abutting Arlberg Road is 30 feet.								
¹¹ <u>Zero Lot Line Setbacks</u> - Where adjoining property owners agree to connect buildings or cooperate in the design of a public passageway or courtyard between them, a zero lot line setback is allowed on one side. Buildings connecting on the property line shall appear on the exterior to be two different buildings.								
¹² <u>FAR Incentives for Structured Parking</u> - Maximum FAR may be increased from 0.7 to 1.35 for uses in where structured or underground parking is provided.								

5. Table of Dimensional Standards: Other Districts

TABLE 21.09-9: TABLE OF DIMENSIONAL STANDARDS OTHER GIRDWOOD DISTRICTS							
Use	Lot Dimensions		Minimum Setbacks (ft)			Building Bulk and Height	
	Min Area (Sq Ft)	Min. Width	Front	Side	Rear	Max. Height	Max. Lot Coverage
GA: Girdwood Airport District							
All uses, ≤ 1 acre	10,400	80 ft	20	10 ¹³	10 ¹³	25 feet	Unrestricted
All uses, > 1 acre			25	15 ¹³	15 ¹³		
GOS: Girdwood Open Space District							
All uses	10,400	70 ft	25	25	25	2 stories, not to exceed 35 ft	10%
GIP: Girdwood Institutions and Parks District							
All uses	8,400	70 ft	25	25	25	2 stories, not to exceed 35 ft	30%
GCR-1: Commercial Recreation (Lower Valley Development Reserve) District							
All uses	All dimensions same as gR-2.						

TABLE 21.09-9: TABLE OF DIMENSIONAL STANDARDS OTHER GIRDWOOD DISTRICTS							
Use	Lot Dimensions		Minimum Setbacks (ft)			Building Bulk and Height	
	Min Area (Sq Ft)	Min. Width	Front	Side	Rear	Max. Height	Max. Lot Coverage
GCR-2: Commercial Recreation (Glacier-Winner Creek) District							
All uses	50,000	100 ft	25	25	25	2 stories, not to exceed 35 ft	10%
GCR-3: Commercial Recreation (Crow Creek Historic Mine) District							
All uses	50,000	100 ft	25	25	25	2 stories, not to exceed 35 ft	10%
GDR: Development Reserve District							
All uses	10,400	70 ft	25	25	25	2 stories, not to exceed 35 ft	10%
GRR: Recreation Reserve District							
All uses	10,400	70	25	25	25	2 stories, not to exceed 35 ft	10%
GW: Girdwood Watershed District							
All uses	50,000	100 ft	25	25	25	2 stories, not to exceed 35 ft	10%
ADDITIONAL SPECIFIC STANDARDS:							
¹³ In the Girdwood Airport district, the minimum setback along any property line contiguous with the GOS district shall be 20 feet, if the lot is less than or equal to one acre, and shall be 30 feet, if the lot area is greater than one acre.							

(AO 2012-124(S), 2-26-13; AO 2013-117, 12-3-13)

21.09.070 SITE DEVELOPMENT AND DESIGN STANDARDS

A. Purpose and General Goals

The purpose of the standards is to ensure new development avoids adverse impacts on the environment and natural resources while maintaining and enhancing the appearance and character of the valley. Specific purposes of the standards include:

1. To help maintain high quality living environments, small-town character, and the presence of the natural landscape within Girdwood neighborhoods;
2. To preserve and reinforce the unique natural qualities of the site, to fit the building into the land to leave its natural landforms and features intact; and
3. To treat the building as an integral part of the natural environment and an attractive addition to the Girdwood community.

B. Applicability

Except as specified below, all development in Girdwood shall comply with the following development and design standards. The standards shall apply in addition to any standards contained in chapter 21.05, *Use Regulations*, and the following sections of chapter 21.07: 21.07.020, *Natural Resource Protection*; 21.07.040, *Drainage, Storm Water Treatment, Erosion Control, and Prohibited Discharges*; 21.07.050, *Utility Distribution Facilities*; 21.07.070, *Neighborhood Protection*; 21.07.090, *Off-Street Parking and Loading*; and 21.07.140, *Operational Standards*. In case of any conflict, the standards in this section shall apply.

Alternative development standards proposed through the master area planning and/or master development planning process shall be equivalent to or exceed the generally applicable development standards and shall result in high-quality, environmentally sensitive development, keeping with the intent of this chapter and the character of Girdwood.

C. Hazard Areas

All development lots, except for lots to be developed with ski slopes, platted after [date of adoption] shall comply with the following standards:

1. No lot shall be located entirely within a high hazard avalanche area or rockfall area, or have an average slope of greater than 35 percent; and
2. A lot located so that portions of the lot are within a high hazard avalanche area or a rockfall area, or where portions of the lot are steeper than 35 percent, shall be designed so that there is an adequate building site which is outside of the above-listed areas.

D. Grading and Drainage

1. Intent

This section is intended to set basic standards for grading and drainage, to reduce the drainage impacts from new development on existing development.

2. Applicability

This section shall apply to all new development in Girdwood.

3. Grading

Grading required for development shall mimic natural forms and blend into the existing landscape on the site. After completion of grading, restoration of slopes to natural-appearing conditions is required.

4. Drainage and Storm-Water Run-off

Run-off from a site shall be controlled and directed to drainage ditches in the road right-of-way or to drainage swales at the property line. Pre-existing drainage patterns onto

neighboring lots may be maintained, but additional drainage shall not be directed onto neighboring lots as the result of new development.

E. Landscaping, Vegetation, and Tree Retention

1. Intent

An important characteristic of Girdwood is the forested landscape and the continuity of natural habitats. The purpose of this section is to retain trees and natural vegetation by specifying the quantity of vegetation required in a development.

2. Permit Required

Clearing and grubbing of any lot or tract shall not exceed 6,000 square feet without first obtaining a land use permit and, if necessary, any other development approvals required by this chapter and title 21.

3. Applicability

This section establishes the minimum vegetation coverage standards for multifamily residential and non-residential development, and for any residential subdivision of two or more lots. Except for subsections 6.b. and 8, below, these standards shall not apply to existing single-family lots or in the gR-1, gR-2, gR-2A, and gR-4 districts.

4. Minimum Vegetation Coverage

a. Amount

The standards given in table 21.09-10 are the minimum percentage of any lot to be maintained as natural vegetation, as defined at 21.09.070E.3.c, and permeable surface, as defined at 21.09.050D.5.

	Single-family or Two-family Residential	Multifamily Residential	Commercial or Public / Institutional	Industrial
Natural Vegetation	30%	20%	10%	5%
Total Permeable Surface, including Natural Vegetation	50%	40%	20%	10%

b. Location and Dimensions

Required vegetated areas may be located anywhere on the site or lot. Individual vegetated areas shall be a minimum of 200 square feet, with no dimension less than 10 feet.

c. Natural Vegetation

Natural vegetation means either existing vegetation left in its natural state, or landscaping provided according to the following:

- i. Evergreen trees a minimum of five feet high, with a ratio of height to spread no less than five to three, and deciduous trees a minimum of eight feet high, with a caliper no less than one and one-half inches, planted at average intervals not greater than 15 feet on center. No more than 50 percent of the trees may be deciduous.

- ii. Three shrubs per tree, each shrub a minimum of 18 inches in height, and ground cover or mulches, placed so that the ground will be covered within three years.

5. Planting Materials

All new trees planted for required landscaping shall have the following characteristics:

a. Evergreen Trees

Evergreen trees shall be native Alaska species. Sitka spruce and hemlock are encouraged to be used because of their predominance and adaptability for survival in Girdwood. If nursery grown, the trees shall be a minimum of five feet in height, with a ratio of height to spread not less than five to three. Field collected specimens shall be a minimum of 24 inches in height.

b. Deciduous trees

Deciduous trees shall be a minimum of eight feet in height and 1 ½ inches caliper.

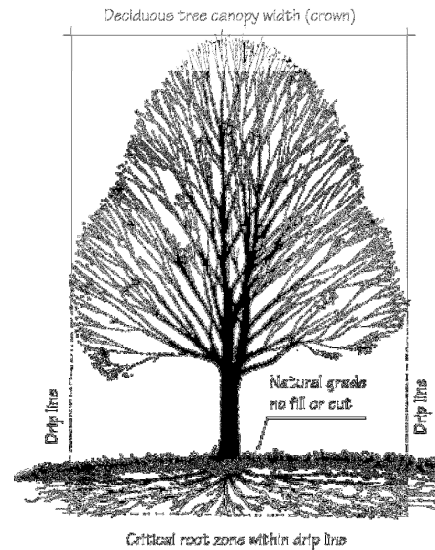

Critical Root Zone

6. Setback Area Vegetation

a. General

The purpose of this section is to retain vegetation in setbacks and along street frontages. Required vegetation for setbacks may be used to count toward vegetation coverage requirements in subsection 3., above.

b. Alyeska Highway Frontage Setback Vegetation

All vegetation within 25 feet of the Alyeska Highway right-of-way shall be retained, except to accommodate a driveway, a utility easement, or utilities located by permit.

c. Buffering Non-Similar Uses

Setbacks between commercial/ industrial and residential properties, and between multifamily and single/ two-family residential properties, shall be retained as natural vegetation areas.

7. Tree Protection During Construction

a. Ski Trail Construction

Trees designated to be retained to comply with this section shall be delineated through such methods as paint marking or flagging.

b. Other Construction

Trees designated to be retained to comply with this section shall be protected during construction by use of sturdy fencing or other firm barriers placed at the drip line. Grading is not permitted within 10 feet of the trunk, or within the critical root zone (drip line), whichever is greater, of any tree to be retained as part of the natural vegetation requirement.

8. Re-vegetation of Disturbed Areas

All ground surfaces on the site, disturbed during construction and not to be occupied by buildings, structures, storage yards, drives, walks, pedestrian areas, off-street parking or other authorized installations, shall be re-vegetated with plant material of the landowner's choice. However, the plant materials shall not be invasive plants as listed in the Selected Invasive Plants of Alaska booklet produced by the United States Department of Agriculture and the Forest Service, Alaska Region. To promote re-vegetation, biodegradable erosion

control netting or mulch blanket shall be used on disturbed slopes steeper than 3:1 (run to rise). Slopes shall be stabilized and re-seeded before September 1. The re-seeding material shall be erosion control vegetation, such as those with aggressive, non-sod-forming, rooting habits. Ski slopes are exempted from this provision.

F. Transportation and Connectivity

1. Street Types

The three street types are arterial, collector, and local, as set forth in the *Official Streets and Highways Plan*.

2. Municipal Street Standards

All collector and local streets shall meet the standards and requirements set forth in the *Design Criteria Manual*, except as specifically provided otherwise in this chapter, to preserve and enhance the unique character and aspirations of Girdwood.

3. Collector Streets – General

Except as provided in section 4. below, a collector street has the following attributes:

- a. The street shall be paved over an engineered base; and
- b. Paved shoulders shall be provided; and
- c. Swales or drainage ditches on each side of the street shall be provided to accommodate surface drainage and snow storage; and
- d. Swales and drainage ditches shall be planted with natural grasses and/or hardy perennials; and
- e. A paved pedestrian path/bikeway shall be provided on at least one side of the street and detached if possible; and
- f. Buffers of native vegetation shall be retained on both sides of the street; and
- g. On-street parking shall be prohibited, except where allowed in subsection 4., below; and
- h. Driveways, subject to subsection 21.09.070N., are permitted as follows: Swale and drainage ditch crossings shall use culverts.
- i. The dimensions of the collector street cross-section shall be as illustrated below:

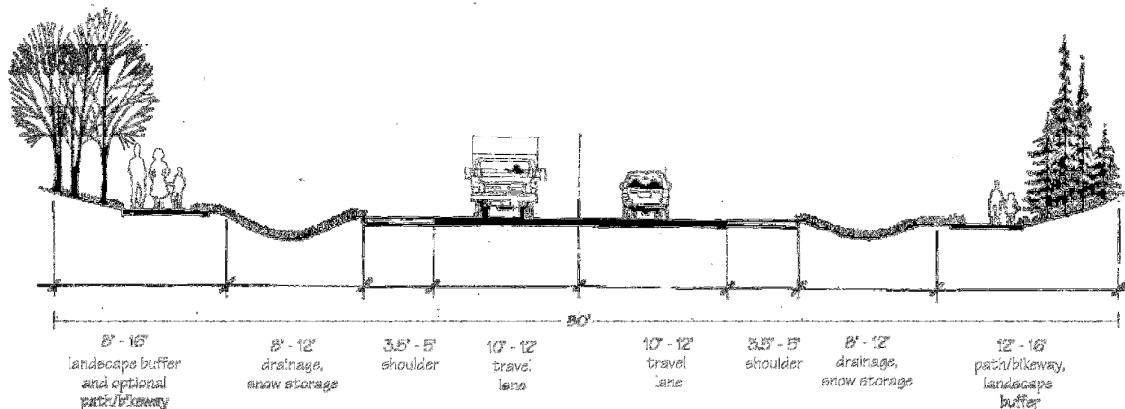

Collector Street Dimensions

4. Townsite Commercial Area Streets

Streets in commercial townsite areas shall differ in design from the general street standards in order to support the main street commercial and mixed-use environments intended for the old and new townsite areas. Townsite streets have the following attributes:

- a. The street shall be paved over an engineered base; and
- b. Curb and gutter shall be provided where practicable; and
- c. The street shall be designed to accommodate on-street parking to the maximum extent feasible; and
- d. A paved sidewalk seven feet or greater in width shall be provided on both sides of the street, and may be back-of-curb; and
- e. Individual driveways for each individual lot are discouraged, in order to limit the number of curb cuts, minimize pedestrian-vehicle conflicts, increase the continuity of main street pedestrian networks, and maximize the number of on-street parking spaces.

5. Local Residential Streets

A local residential street has the following attributes:

- a. The street shall be paved, or shall be a non-dust-generating non-porous material, such as RAP or chip-seal, over an engineered base; and
- b. Swales or drainage ditches on each side of the street shall be provided to accommodate surface drainage and snow storage; and
- c. Swales and drainage ditches shall be planted with natural grasses and/or hardy perennials; and
- d. A pedestrian path/bikeway of at least five feet in width and either paved, or treated with a non-dust-generating material, shall be provided on at least one side of the street and detached if possible; and
- e. Driveways, subject to section 21.09.070N., are permitted.
- f. The dimensions of the local street cross-section shall be as illustrated below:

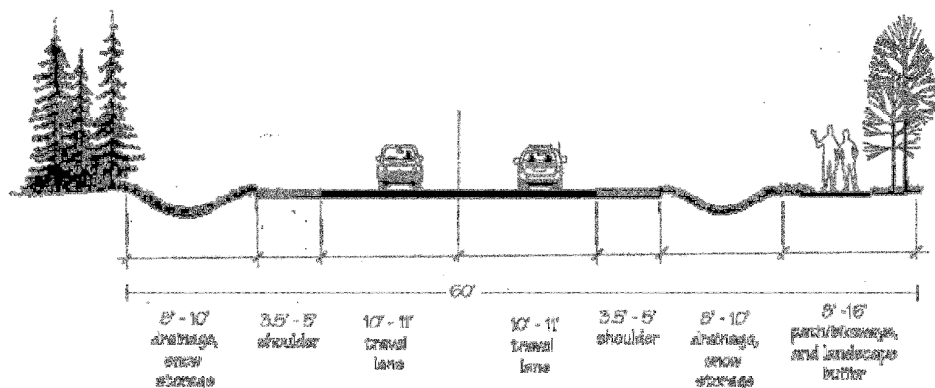

Local Residential Street Dimensions

6. Neighborhood Connectivity and Distribution of Traffic

a. Purpose

The purpose of the standards is provide a well-connected street grid. The design requirements do not mandate a rectilinear or uniform grid; the requirements shall, however, result in a network distributing traffic evenly and equitably, and ensuring good access for emergency services equipment. Such a street network reduces the daily miles of vehicular travel in the valley by providing direct, non-circuitous routes for drivers and by encouraging walking and bicycling.

b. Connectivity Standards

- i. Within contiguous residential and commercial developments, no local street may be developed longer than 450 feet, unless the street is connected to another street at each end.
- ii. Within contiguous residential and commercial developments, local streets shall have at least nine intersections per mile.

G. Lighting

1. Street and Trail Lighting Standards

a. Applicability

This section applies to street and trail lighting, and is subject to the provisions of the Design Criteria Manual, except as specifically provided in this section, in order to preserve and enhance the unique character and aspirations of Girdwood. This section does not apply to site lighting, including alpine ski slope lighting. The lighting standards in this section do not apply to state-maintained roads.

b. Location

Street lights shall be installed where required by the Traffic Engineer for vehicle and/or pedestrian visibility and safety. Street lighting on local residential streets should be avoided if possible.

c. Lighting Color

Fixtures for street and trail lighting shall use white light sources with a color rendering index (CRI) of 65 or greater.

d. Poles

i. Local Streets and Intersections

Street light poles at intersections of local streets with local streets, and along local streets, shall not exceed 20 feet in height.

ii. Collector Streets and Intersections

Street light poles at intersections of collector streets with collector streets, and of collector streets with local streets, shall not exceed 25 feet in height.

iii. Arterial Streets

Street light poles along arterial streets shall not exceed 35 feet in height.

iv. Trails

Trail light poles shall not exceed 16 feet in height. Poles shall be of treated wood or painted metal.

e. Fixtures

Street and trail lighting shall be full cut-off, as defined by the Illuminating Engineering Society of America (IESNA).

Full Cut-off
Luminaire

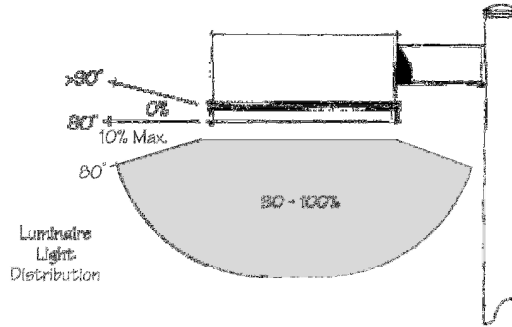

- f. **Trail Lighting**
Pedestrian trails along collectors and arterials shall be lit.

2. **Exterior Site Lighting**

a. **Applicability**

This section shall apply to site lighting, building lighting, and parking lot lighting in all developments, except for alpine ski slopes and single- and two-family developments.

b. **Light Poles**

Light poles shall not exceed 14 feet in mounting height, except light poles for parking lots in the gC-1, gC-2, gl-1, and gl-2 districts may be up to 20 feet in mounting height. Poles shall be non-reflective, neutral and dark in color, blending into the site's nighttime backdrop.

c. **Shielding, Glare and Light Trespass**

Exterior site and building wall lighting shall be designed and located to direct light toward the ground, to minimize glare or light trespass onto adjacent properties or light pollution in the valley. The light source shall not be visible at the property line, provided, however, light fixtures for walkways may have a visible light source if diffused by a translucent cover, such as frosted glass. Upward-directed exterior lighting is prohibited, unless the light beam is directed only toward, and is contained within, the mass of the ceiling, wall, tree or other feature to be illuminated.

d. **Lighting Color**

Fixtures for area lighting shall use white light sources, such as one of the following, without limitation: Color corrected metal halide, induction, compact fluorescent, incandescent (tungsten-halogen), or high-pressure sodium with a color rendering index (CRI) of 65 or greater. Lights at building entrances, steps, stairs, ramps, driveway crossings and entrances to parking structures or garages may be incandescent. Aesthetic landscaping or building facade lighting is exempt from color restrictions.

e. **Parking Lot and Display Lot Lighting**

Parking lot and display lot lighting fixtures shall be full cut-off fixtures, as defined by the Illumination Engineering Society of North America.

f. **Athletic Playing Fields**

The standards set forth in this section shall not apply to lighting of public athletic playing fields.

H. Pedestrian Circulation

1. Applicability

All multiple-family residential and non-residential developments shall meet the minimum standards of this section.

2. Walkway System – Residential

In multifamily projects, and in attached single-family and two-family dwelling projects containing more than two residential buildings, paved and lighted walkways shall be provided from individual units or common building entries to parking lots and to paved public trails or sidewalks abutting the property. The maximum grade on pedestrian walkways is five percent without a handrail, or eight percent if a handrail is provided.

3. Walkways System – Community and Commercial Uses

Walkways shall connect parking lots to sidewalks and building entrances. There shall be a connecting walkway between all buildings in a multiple building development. Walkways and sidewalks shall have an unobstructed width of no less than five feet. When walkways adjoin areas used by vehicles for driving or parking, walkways shall be defined by curbs, plant beds, bollards, or other materials, to create a well-defined physical separation between the uses.

4. Weather Protection

Exterior stairways to habitable upper levels, and any pedestrian walkways exposed to snow shedding from roofs, shall be covered.

I. Fences and Walls

1. Fences in Residential Districts

Fences up to eight feet in height are permitted in side and rear setback areas, where needed for child safety, privacy, security, or animal control. However, in no case shall fences extend into the setbacks for more than 30 percent of the total linear perimeter of the lot. Fences are prohibited in the front setback.

2. Walls in Nonresidential Sites

Low walls on any nonresidential site shall be of local stone, or stone of comparable appearance, or heavy timber wide enough to allow for comfortable seating when located adjacent to walkways. When connected to a building, the wall shall duplicate the building base material.

3. Fences and Walls in Commercial Districts

Fences less than 42 inches in height may be constructed in front setbacks. Except as otherwise provided in the gC-7 district-specific standards, fences and free-standing walls, up to six feet high, may be constructed within the side and rear setbacks. Fences associated with golf driving ranges are exempt from this section.

4. Fences and Free-Standing Walls in Industrial Districts

Fences and freestanding walls up to eight feet high may be constructed within side and rear setbacks. A fence up to eight feet high may be constructed in the front setback, but it shall not be sight-obscuring.

J. Utilities and Utility Equipment Standards

1. Commercial, Industrial, and Multiple-Family Residential

a. *Undergrounding of Utilities*

New utilities, including electrical distribution lines, shall be placed underground. Utility easements shall be dedicated to allow future access to the underground lines. Existing and proposed utility lines shall be depicted on the site plan.

- b. ***Location of Underground Utilities in gR-3 and gR-5 Districts***
Underground utility lines in the gR-3 and gR-5 districts shall avoid disturbing natural vegetation, and shall be placed in the right-of-way in front of lots, and not along side or rear lot lines, except where needed to create looped systems. Pad-mounted facilities may be located in easements abutting rights-of-way.
- c. ***Location of Above-Ground Utilities***
Above-ground utility enclosures, such as transformers, major telephone equipment boxes, and similar facilities, shall be located a minimum of 20 feet from entrances to dwelling units, driveways, or garage entrances. Above-ground utilities shall be located to minimize visibility from entries, and above-ground utilities not mounted on the building shall be screened with vegetation. Electric and gas meters and fire sprinkler risers shall be located within the building service area for structures with a separate service entry or, in the absence of a separate service entry, on side or rear walls.
- d. ***Design Standards for Above-Ground Utilities***
Except as necessary for safety and maintenance, above-ground utility boxes shall be screened from the road right-of-way with vegetation or with screening constructed of stone, wood, or textured concrete block.

2. **Single-Family Residential**

- a. ***Undergrounding of Utilities***
New utilities, including electrical distribution lines, shall be placed underground. Utility easements shall be dedicated to allow future access to the underground lines. Existing and proposed utility lines shall be depicted on the site plan.
- b. ***Alyeska Highway Utilities***
Utilities to be extended to lots along Alyeska Highway shall be placed under driveways, to the maximum extent practicable.

K. **Snow Management**

1. **Commercial, Community, Industrial, and Residential Uses**

- a. ***Applicability***
 - i. Single-family, two-family, and townhouse dwellings on individual lots are exempt from this section.
 - ii. Applicants in Girdwood may instead comply with the generally applicable snow storage provisions of section 21.07.040F., except that storage of snow is prohibited in natural vegetation areas required by subsection 21.09.070E.4.
- b. ***Snow Storage Area***
Snow storage space adjacent to surface parking lots and pathways shall be identified on the site plan. To facilitate snowplowing and snow removal, snow storage areas equal to at least 20 percent of the total area of the site used for parking, access drives, walkways, and other surfaces needing to be cleared of snow, shall be designated on the site plan.
- c. ***Exemptions and Alternatives***
 - i. Minimum snow storage area requirements may be waived for properties within the boundaries of a public parking, local improvement, or snow management district where district-wide snow removal services is provided.
 - ii. If snow will be removed off-site to an approved snow disposal site, or another alternative snow management strategy is used, then the minimum

snow storage area requirement may be reduced or waived, subject to the standards of subsection 21.07.040F.5., *Alternative Snow Management Strategies*.

iii. Vehicle driveway and parking lots and pedestrian walkways with heated surfaces for melting snow shall be exempt from snow storage area requirements.

d. **Snow Storage and Drainage**

The location of snow storage areas shall be coordinated with drainage plans so the stored snow does not block meltwater from swales and drains.

e. **Snow Storage and Landscaping**

Areas designated for snow storage shall be landscaped only with groundcovers and shall have positive drainage away from structures and pavements. Storage of snow is prohibited in required natural vegetation areas.

L. **Off-Street Parking Standards**

1. **General**

Required parking shall be provided in accordance with section 21.07.090, except as specified in this section. The director may waive an off-street parking requirement if sufficient public parking in the district satisfies off-street parking requirements.

2. **gC-5, gC-8, and gC-9 Districts**

Required parking for any non-residential use in the gC-5, gC-8 or gC-9 districts may be located off-site within the adjoining right-of-way or within 600 feet of the site in community parking facilities under a municipal parking agreement. Properties may also use the reduced parking requirements and parking reductions provided in section 21.07.090. (RESERVED: Tailored parking requirements and reductions for the new townsite area will be further developed in coordination with the update to the *Girdwood Area Plan* and adopted as an amendment to this section.)

3. **gC-7 District**

In the gC-7 district, on-site parking for new commercial development is prohibited. Parking for new commercial development shall be located within the adjoining right-of-way, or in community parking lots under a municipal parking agreement. Required parking for upstairs dwelling units in the gC-7 district may also be located off-site. Any on-site parking for residential units shall be located on the side or rear of the principal building and enclosed within a garage architecturally compatible with the principal building and no closer to the street than the building's primary front façade. On-site parking in the rear setback is prohibited.

4. **Parking Lot Location – Residential**

Parking for multifamily dwellings or multiple residential dwelling structure projects is prohibited in any required setback. All surface parking lots shall be screened from adjacent streets, properties, and public trails through the use of retained vegetation and/or landscaping encompassing the front setback, with breaks for driveways and walkway access.

5. **Parking Lot Location – Nonresidential**

Parking is prohibited in any required setback, except in the gC-3 district as provided in subsection 21.09.040C.2.c.iii.(B).

6. **Parking Lot Landscaping**

Public and private parking lots shall have a 20 foot landscaped break in any line of parking spaces over 20 cars long and a minimum 15 foot landscaped strip between every other double-loaded bay of cars.

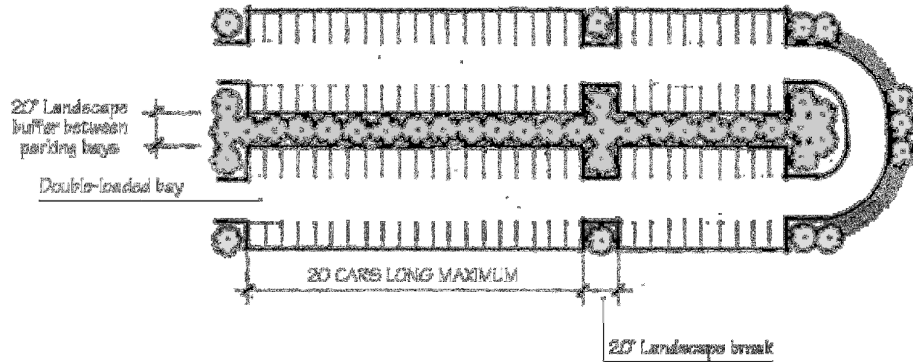

Parking Lot Landscaping

7. Parking Within Multifamily and Non-Residential Structures

Parking structures for more than two cars within multifamily and nonresidential structures, shall be constructed at least half a level below grade or, if constructed at grade, shall be earth covered using berming at least a half level on all sides. Vegetative and/or architectural screening of multiple level parking structures is required. The mechanical equipment required to vent enclosed parking shall be located away from outdoor play areas or entries, public rights-of-way and pedestrian spaces, and shall be completely screened from view.

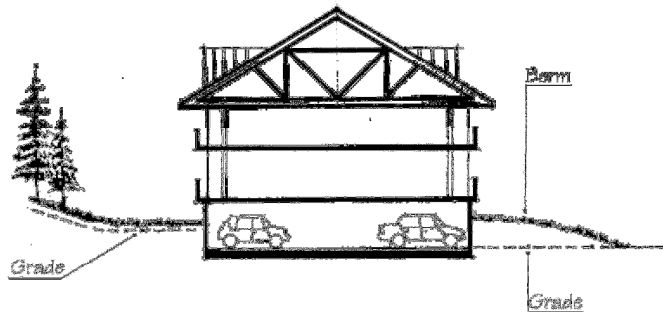

*Parking within
Multifamily and Non-
Residential Structures*

8. Parking Surfacing Materials

Interior roads, driveways, and parking lots shall be paved, except paving of driveways and surface parking lots for single-family and two-family residences is not required.

M. Signage

Except as set forth below, the generally applicable sign standards contained in chapter 21.11, *Signs*, shall apply. The regulations set forth below shall apply in addition to those contained in chapter 21.11, except in case of conflict, in which case the regulations below shall govern.

1. Commercial and Industrial Signs

The following standards apply to signage for any commercial or industrial use, except for Fueling Stations, as set forth in subsection 4., below. Directional and wayfinding signs are exempt from this section.

a. **Freestanding Signs**

i. **Number**

A single, freestanding sign is allowed, but shall not be placed in the right-of-way, or in the sight distance triangle as defined in subsection 21.09.050D.

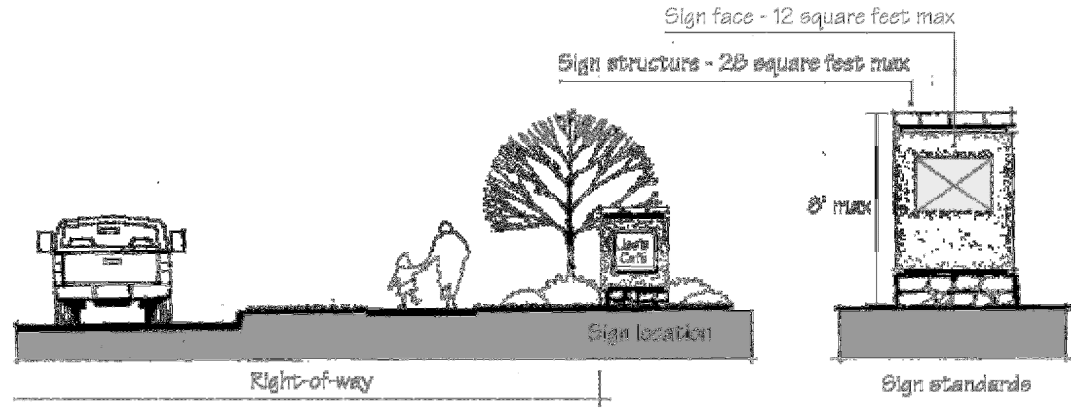

Freestanding Commercial Sign

ii. **Maximum size and height**

The maximum size shall be 12 square feet per face. The sign shall be monument-style, ground mounted, and shall not exceed a maximum height of eight feet. There may be lettering on both sides. The total area of each face of the sign, including the structural base, shall not exceed 28 square feet.

iii. **Materials**

Signage materials shall be complementary to the architectural character and materials of the principal building.

iv. **Style and Color**

The letter style and color of freestanding identification signs shall be consistent with those used on other signs close to or attached to the building. If the sign is internally illuminated, the background shall be a translucent darker color, with a lighter contrasting color for the letters and symbols.

v. **Electronic Changeable Copy Signs**

Electronic changeable copy signs or signs with flashing lights or highly reflective elements are prohibited.

vi. **Icon Signs**

Developments subject to a master plan requirement may have one icon sign exceeding the size and height limits specified in this section. An icon sign is a sign using natural materials, such as logs or stone, and is designed to keep with the character of a mountain resort community and emblematic of the primary use on the site (e.g., skiing). The dimensions of the icon sign shall be determined and approved as part of the master planning process.

b. **Building Signs**

i. **Maximum Area**

In addition to freestanding signs, each commercial building on a lot shall have a total building signage area allowance for each side of the building

facing a public right-of-way, based upon the width of the building frontage as follows:

Building Frontage Width (ft.)	Square Feet Allowed
< 20	10
20-30	15
31-40	20
41-50	30
>50	40

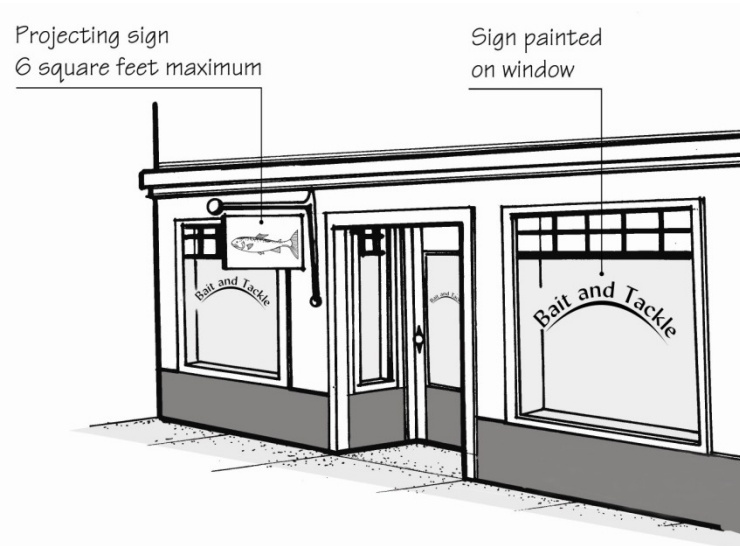

Commercial Building Signage

ii. *Types of Signs*

The total area of all signs shall not exceed the amount set forth above.

(A) *Projecting Sign*

Each occupant of a commercial building is allowed a single projecting sign. The maximum size of a hanging or projecting sign shall be six square feet. Projecting signs shall be at least 6' 10" above a walkway and may not extend more than five feet from the building façade. The lettering may be on both sides.

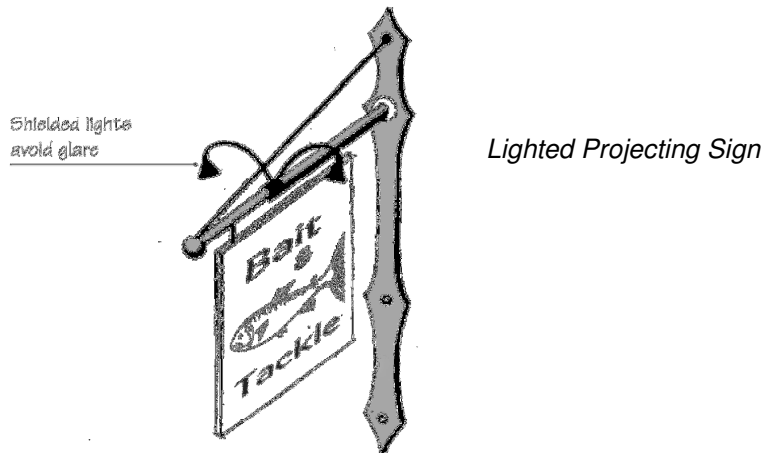

(B) *Window Signs*
Permanent window signs shall cover no more than 30 percent of the window area, but 50 percent of that sign area must be transparent.

(C) *Other Signs*
Other allowed signs may be flush-mounted, painted on doors or windows, mounted on awnings, canopies and arcades, or attached to railings. Flush-mounted or painted signs shall be at the ground floor level.

iii. *Materials and Colors*
Permitted sign materials are wood, metal, stone, ceramic, glass, or plastic surface mounted on a wood or metal backing. The surface shall be painted, stained or treated to ensure durability.

iv. *Lighting*
Internally lit signs are not permitted, except logos and channel signs consisting of individual letters may be internally lit. External illumination shall be shielded and be directed downward to shine only on the sign area to be illuminated.

v. *Electronic Changeable Copy Signs*
Building signs with electronic changeable copy are prohibited in Girdwood.

vi. *Operational Information Signs*
If window or door space used to display operational information, such as phone numbers, address, hours of operation, charge cards accepted, or similar information, is less than a rectangle 12 by 18 inches in size, the sign does not count against the maximum area specified above.

vii. *Temporary Sign*
The display of temporary sales signs, advertisements or other signage is prohibited on the outside of buildings.

2. Residential Uses

a. *Multiple-Family*

The standards for signs for multifamily buildings in residential districts (section 21.11.050) shall apply to multiple-family residential.

b. *Single-Family, Two-family and Townhouse*

The sign standards of section 21.11.050 shall apply to a single-family dwelling, duplex or townhome, except only one freestanding identification sign shall be allowed for any residential subdivision.

3. Community Uses

The sign regulations set forth in section 21.09.070M.1. (*Commercial and Industrial Signs*) shall apply to community uses. Signage for public buildings that are intended as civic landmarks shall be compatible and integrated with the architectural character, proportions, and details of the building.

4. Fueling Station Signage

a. *Primary Freestanding Signage Height and Area Maximums*

A fueling station may have a primary freestanding sign up to 25 feet in height, not to exceed 30 square feet in area, and one road front entrance sign on each road frontage, each sign not to exceed eight feet in height or 20 square feet in area.

- b. **Fuel Price Signs**
One sign identifying fuel prices is permitted, not to exceed four panels four feet square, to be arranged in a square or vertical format, not to exceed 12 feet in height.
- c. **Instructional Signs**
Up to six instructional signs are permitted, each not to exceed two feet square, to guide traffic movement and parking.

5. Grocery Store Signage

In spite of subsection 1. above, a grocery store with 15,000 or more square feet gross floor area and with multiple points of vehicle site access may have two freestanding signs, each sign shall not to exceed a total of 20 square feet. No more than 25 percent of window area may be used for signage, including signs located inside but readable from four feet away from the building.

6. Bed and Breakfast Signage

A bed and breakfast shall have and maintain the appearance of a single-family detached dwelling unit or a dwelling unit of a two-family dwelling. No more than one non-illuminated sign is permitted to reflect the operation of a bed and breakfast, and the sign may be one of the following:

- a. A maximum one square foot sign, mounted flat against the principal building; or
- b. A post and sign located on the property, no more than ten feet from the driveway. The sign area is limited to two and one-half square feet, and the framing area is limited to 15 square feet.



Framing area, defined by the combined outer limits of the sign and all frames and supports.

Bed and Breakfast Signs

N. Driveway Standards

1. Intent

To maintain the natural qualities of the site, driveways shall be of minimum width, follow site contours, and be routed to preserve amenities such as rock outcroppings and stands of mature trees. Driveways shall be designed with safety as a priority, with as little gradient as practicable.

2. Driveway Standards for Residential Uses

TABLE 21.09-11: DRIVEWAY STANDARDS FOR RESIDENTIAL USES		
	Single-family/ Two-family Uses	Multiple-family Residential
Minimum width	10 feet	12 feet
Maximum width per driveway This applies to the length of the driveway within a setback and public right-of-way.	20' wide maximum	one-way driveway – 14' max. width two-way driveway – 24' max. width
Two driveways	If two driveways are used for either a single family or a two family lot, they each shall be no more than 10 feet wide.	The total width of both driveways measured within a setback and public right-of-way shall not exceed 40 percent of the frontage of that lot on the street.
More than two driveways	Not allowed.	Allowed if it is shown that they will substantially improve circulation safety both on and off site. All other standards of this subsection apply.
Separation between driveways on a single lot	A minimum 10' wide vegetated separation required where there is more than one driveway to the same street.	
Slope	Slopes of up to 10 percent are allowed on all residential driveways. Driveways with slopes greater than 10 percent require prior approval by the municipal traffic engineer.	
Materials	Compactible material suitable for intended use. Surface course or pavement of any type is optional.	Concrete or asphalt compound to the standards prescribed by the traffic engineer.

3. Driveway Standards for Commercial Districts and Nonresidential Uses in Residential Districts

TABLE 21.09-12: DRIVEWAY STANDARDS FOR COMMERCIAL DISTRICTS (sf = square feet)							
	gC-1, gC-2		gC-3, gC-4		gC-5 through gC-104		
	≤5,000 sf lot	>5,000 sf lot	≤5,000 sf lot	>5,000 sf lot	≤5,000 sf lot	5,000 - 43,560 sf lot	>43,560 sf lot
Minimum width	12 feet	12 feet	12 feet	12 feet	12 feet	12 feet	12 feet
Maximum width per driveway ¹⁴	24 feet	28 feet	24 feet	24 feet	24 feet	24 feet	24 feet
Maximum width of each driveway for two driveways ¹⁴	Not allowed	28 feet	Not allowed	14 feet	Not allowed	14 feet	24 feet
More than two driveways	Lots are allowed a maximum of two driveways per frontage.		Lots are allowed a maximum of two driveways per lot.		Allowed if it is shown to improve circulation safety, on and off site		
Separation between driveways	Where separate driveways are provided on a lot in a GC district, there shall be a naturally vegetated or landscaped area at least 20 feet wide between the driveways. The separation area may not be used for the parking of vehicles.						
Slope	Slopes of up to 10% are allowed on all commercial driveways. Driveways with slopes of 10-15 percent require prior approval of the municipal traffic engineer.						
Orientation	Within the required front setback on any lot, driveways shall run perpendicular to the street.						
Materials	Concrete or asphalt compound to the standards prescribed by the traffic engineer. Permeable materials are allowed if approved by the municipal traffic engineer.						
¹⁴ Maximum width may be exceeded when approved by the municipal traffic engineer.							

4. Driveway Standards for Industrial Districts

TABLE 21.09-13: DRIVEWAY STANDARDS FOR INDUSTRIAL DISTRICTS		
	gl-1	gl-2
Maximum width One driveway	30 feet	30 feet
Maximum width Two Driveways	30 feet each	30 feet each
More than two driveways	Not allowed	
Separation between driveways	Where separate driveways are provided on a lot, there shall be a naturally vegetated or landscaped area at least 20 feet wide between the driveways. The separation area may not be used for parking vehicles.	
Slope	Driveways shall not exceed a slope of 10 percent.	
Orientation	Within the required front setback on any lot, driveways shall run perpendicular to the street.	
Materials	Concrete or asphalt compound to the standards prescribed by the municipal traffic engineer.	

5. Driveway Standards for Other Districts

a. Number and Width

i. GA District

A lot in the GA district may have up to two driveways with a maximum width of 30 feet.

ii. GOS and GIP Districts

The maximum width and maximum number of driveways shall be as specified below.

(A) Up to 5,000 square foot lot: One driveway, maximum 24 feet wide; or

(B) Greater than 5,000 square foot lot: One driveway, maximum 24 feet wide; or two driveways, maximum 14 feet wide.

iii. GDR and GRR Districts

One driveway, maximum 24 feet wide; or two driveways, maximum 14 feet wide.

b. Separation Between Driveways

i. GA district

If two driveways are on the lot, there shall be a minimum 20 foot separation between the two driveways.

ii. GOS, GIP, GDR and GRR Districts

Where separate driveways are on a lot, there shall be a vegetated area (either natural or landscaped) at least 20 feet in width between the two driveways. The vegetated area between sections of driveway may not be used for the parking of vehicles.

c. Orientation

i. GA, GOS, GIP, GDR and GRR Districts

Within the required front setback on any lot, driveways shall run perpendicular to the street.

d. Slope

i. GOS, GIP, GDR, and GRR Districts

Driveways shall not exceed a slope of 10 percent.

O. Trash Management in Multi-Family, Commercial, Industrial, and Resort Districts

1. The placement of refuse containers in the front setback is prohibited.
2. All refuse containers stored outdoors shall be bear-proof.
3. Refuse containers shall be screened from public view within a three-sided structure. Enclosures shall be durably constructed and designed to be consistent with the primary structure(s) on the property.

(AO 2012-124(S), 2-26-13; AO 2013-117, 12-3-13)

21.09.080 BUILDING DESIGN STANDARDS

A. Purpose and General Goals

The design standards establish control over certain aspects of the design of multiple-family, commercial, and resort development in order to retain the visual beauty and character of Girdwood Valley's natural landscape and to reduce the visual and physical problems arising from poor site planning. Except as modified by an approved development master plan, these standards apply to new or remodeled development, as noted in the specific applicability statements, and related new accessory structures. Specific purposes include:

1. To preserve and reinforce the unique natural qualities of the site;
2. To fit the building into the land in a way to keep natural landforms and features intact; and
3. To treat the building as an integral part of the natural environment and an attractive addition to the Girdwood community.

No part of chapter 21.09, is meant to preclude, discourage, or inhibit the design, installation, or implementation of ecologically sound methods of harnessing and utilizing wind, solar, hydro, or other sources of renewable energy in Girdwood.

B. Alternative Equivalent Compliance

1. Purpose

Alternative equivalent compliance is a procedure that allows development to meet the intent of the design-related provisions of this chapter through an alternative design. It is not a general waiver or weakening of regulations. Rather, the procedure permits a site-specific plan that is equal to or better than the strict application of a design standard specified in this chapter. This procedure is not intended as a substitute for a variance or administrative modification or a vehicle for relief from standards in this chapter.

2. Applicability

The alternative equivalent compliance procedure shall be available only for this section 21.09.080.

3. Procedure

See subsection 21.07.010D. for the alternative equivalent compliance procedure.

C. Single-Family (Detached) Building Design Standards

1. Applicability

The following design standards shall apply in the gR-3 district.

2. Mix of Housing Models

- a. Any development of 10 or more units shall have at least three different types of housing models. Each housing model shall have at least two of the following differentiations:
 - i. Different floor plans;
 - ii. Different placement of the building footprint on the lot;
 - iii. Different garage placement; or
 - iv. Different roof lines.
- b. The development shall be arranged in such a way so whenever any four houses are next to each other along a street, at least one of each of the three required models shall be included in the group of four.

D. Two-Family and Attached Single-Family Building Design Standards

1. Applicability

The following design standards shall apply to all two-family and attached single-family development.

2. Roof Forms and Materials

a. Height

Roofs shall vary in height and, with the exception of shed roofs, the majority of roof ends shall be lower than the center of the structure.

b. Overhangs

Roof overhangs shall be sufficient to provide weather protection for building walls. Overhangs on the gable end shall be a minimum of 12 inches. Overhangs on the eave ends shall be a minimum of 24 inches, except the upper eave end of a shed roof is not required to have an overhang. This standard shall not apply to solariums. Flat-roofed structures shall provide an appropriate means of managing runoff to protect exterior walls.

c. Snow and Rain Protection

Roof forms shall be designed to protect the areas where people stand or enter the building from snow and rain. Roof forms shall protect doorways, exterior stairs, balconies, parking lots, deck entrances, and garage entrances.

d. Roofing Materials

Roofing materials shall be non-reflective.

3. Two-Family Dwelling Building Style

A two-family structure shall appear to be a single-family dwelling unit in architectural form, style, materials and color. "Mirror image" two-family dwellings are prohibited. There shall be a common front entrance or, if separate entrances are desired, the entrances shall be on different sides of the building.

E. Multiple-Family and Townhouse Building Design Standards

1. Applicability

Development of any multifamily residential structure shall, except as specifically provided herein, comply with the standards of this section. When a structure contains both residential and commercial uses, section 21.09.080D., *Commercial Building Standards*, shall apply.

2. **Building Style, Massing, and Size**
 - a. ***Building Style—General***

Although no specific architectural style is required, it is intended the design of buildings take into consideration the Girdwood climate and physical setting. The Girdwood physical environment requires structures to be built for its special circumstances.
 - b. ***Mass***

The mass of a single building or group of buildings shall be organized so it appears to be an arrangement of smaller-sized connected structures. Large roof forms shall step or be broken by dormers. Upper level residential floors may be incorporated into the roof form to reduce the apparent height and mass of buildings.
 - c. ***Scale and Size***

No wall shall be longer than 42 feet without a change or alteration in alignment of at least four feet in depth from the plane of the referenced wall. For building sides longer than 64 feet, the combined length of the segments not in plane with the primary wall plane of the building side shall equal at least one-third of the building side length. Curved walls that include a change in wall plane of at least four feet depth in 40 feet of wall length shall satisfy this requirement. Where two arms or elevations of a building are separated by a change in wall plane of six degrees or more, these shall be considered as separate building sides for the measurement purposes of this provision.
 - d. ***Building Façades***

There shall be trim around openings and windows. Exterior corridors to room entrances are prohibited for buildings with more than eight dwelling units.
3. **Roof Form**
 - a. ***Shed or Pitched Roofs***

Sloping roof forms are encouraged.
 - b. ***Flat Roofs***

Flat-roofed buildings shall be permitted only if the roof areas are divided into separate segments, each no more than 3,000 square feet in area, and separated from adjoining segments by at least four feet in vertical elevation.
 - c. ***Cornices***

Flat portions of roofs shall have distinctive cornice features.
 - d. ***Roof Overhangs***

Roof overhangs shall be sufficient to provide weather protection for building walls. Overhangs on the gable end shall be a minimum of 12 inches. Overhangs on the eave ends shall be a minimum of 24 inches, except an upper eave end of a shed roof is not required to have an overhang. Flat-roofed structures shall provide an appropriate means of managing runoff to protect exterior walls. Solariums are exempt from this subsection.
 - e. ***Snow and Rain Protection***

Roof structures shall be designed to protect doorways, exterior stairs, emergency exits, balconies, vehicle service bays, and garage entrances from snow, ice and rain. Balconies shall be designed to avoid drainage onto other balconies or pedestrian spaces below.

- f. **Roofing Materials**
Roofing materials may be asphalt shingle, metal, slate, or built-up materials on flat sections. Brightly colored enameled, reflective metal, and wood shakes are prohibited roofing materials.
- g. **Projections from Roofs**
 - i. **Location on the Roof**
Chimneys, flues, vents and antennae shall penetrate the roof near the ridge or only where protected from snow movement off the roof. Vent pipes and flues shall be consolidated into orderly clusters or incorporated into chimney structures.
 - ii. **Cladding Material**
Chimneys and metal flue pipes shall be clad in wood, stone, or stone veneer.
- 4. **Porches and Entrances**
 - a. **Landing Height**
Where landings are used, they shall be a minimum of six inches higher than adjacent walkways or streets.
 - b. **Entrances**
Common building entryways shall be a minimum of 12 feet in width or 20 percent of the width of the building wall, whichever is greater. Fire exits are not considered building entrances for the purpose of this section. The entrance shall be weather protected and well lit.
 - c. **Porte Cocheres**
Porte cocheres and porticoes may extend outward from the building entrance over driveways or drop-off areas to provide weather protection. Exterior materials and design shall be consistent or compatible with the building.
- 5. **Building Materials**
 - a. **Durability**
Durable, weatherproof materials shall be used for foundations and the lower sections of building facades subject to the affects of snow accumulations and rain splashback.
 - b. **Alternative Façade Materials**
On multistory buildings, façade materials may include pre-cast concrete or plaster surfaces, if such surfaces are heavily ribbed, textured, or brush hammered, and colored to fit the overall building design and mountain setting. No more than 35 percent of any building façade shall consist of textured or treated concrete.
 - c. **Remodels**
The architectural design and the materials used in an addition to an existing structure, or accessory structure, shall be compatible with the architectural style and building materials used in the existing structure, unless an entire facade is to be remodeled in a uniform architectural style.
 - d. **Restricted Materials**
No more than 20 percent of any given building façade may be composed of aluminum, untextured vinyl or plastic siding, T-111 siding, or brick. Up to 35 percent of any given building façade may be composed of stucco, treated or textured CMU, or simulated stone veneer. No more than five percent of any given building facade may be painted brick.

e. Prohibited Materials

The following exterior materials are prohibited:

- i. Shiny, reflective metal surfaces anywhere on the building;
- ii. Highly reflective or mirrored glass;
- iii. Untreated or untextured concrete or masonry;
- iv. Unstained or untreated wood, except for cedar or redwood; all other wood elements shall be treated with oil, stain, or other weathering agent, or painted to resist weathering and discoloration from water;
- v. Plywood siding without board and batten; and
- vi. White roof gravels.

6. Building Colors

a. Principal Colors

Principal colors on buildings shall generally be natural color tones, such as browns, tans, wood colors, green, rust, barn red and gray. White or cream shades of color are permitted on not more than 35 percent of each facade. Bright, primary colors are permitted on not more than 15 percent of each facade.

b. Trim Colors

Brighter colors than principal building colors are permitted for trim and highlight details, such as cornices, window frames, handrails, and entrance doors.

7. Accessory Elements

a. Detached Parking, Garages, and Carports

Detached garages, carports and parking garages shall be designed with architectural elements and materials related to the principal residential building or buildings, and shall be screened from view from public roads and primary common areas with landscaping and/or berming.

b. Resident Storage and Other Accessory Buildings

A multiple-family project shall provide a minimum of 40 square feet per dwelling unit of covered, enclosed, and secure storage areas for bikes and other belongings typically cannot be accommodated within individual dwelling units. This storage area may be provided as part of a garage. Storage and other accessory buildings shall be designed with materials and/or architectural elements related to the principal buildings.

F. Commercial, Resort and Public/ Institutional Building Design Standards

1. Applicability

- a. Development of any structure containing a use categorized in table 21.09-2 as a community or commercial use shall, except as specifically provided herein, comply with the standards of this subsection. Where a structure contains both residential and commercial uses, the standards of this section shall apply.
- b. The following community uses shall meet the industrial building design standards in subsection 21.09.080G. below rather than the commercial, resort, and community building design standards of this section: aircraft repair, aircraft storage hangar, aviation services, utility facility, and utility substation.

2. **Building Style, Massing and Size**

a. ***Mountain Building Style – Intent***

The design of new buildings shall have the appearance of structures appropriate for Girdwood's climate, mountain valley setting, and small western mining town character. Commercial and resort buildings shall utilize a mountain style defined primarily by the materials, roof pitches, use of porches, and street treatment as set forth below and in section 21.09.070F.

b. ***Residential Building Style – Intent***

New buildings in the old and new Girdwood townsite commercial areas shall have a residential character, even though the zoning permits and encourages commercial uses. Building forms and detail elements shall have predominantly pitched roofs, porches, traditional rectangular windows with a vertical orientation (on the ground floor), avoidance of blank walls or materials associated with industrial uses. Buildings shall consist of relatively small, human-scaled or appear to be an aggregation of smaller, simpler forms. Residential apartments on upper stories are encouraged.

c. ***Mass***

The mass of a single building or group of buildings shall be organized so it appears to be an arrangement of smaller-sized connected structures. Upper level residential floors may be incorporated into the roof form to reduce the apparent height and mass of buildings.

d. ***Scale and Size***

No wall shall be longer than 42 feet without a change or alteration in alignment of at least four feet in depth from the plane of the referenced wall. For building sides longer than 64 feet, the combined length of the segments not in plane with the primary wall plane of the building side shall equal at least one-third of the building side length. Curved walls that include a change in wall plane of at least four feet depth in 40 feet of wall length shall satisfy this requirement. Where two arms or elevations of a building are separated by a change in wall plane of six degrees or more, these shall be considered as separate building sides for the measurement purposes of this provision.

e. ***Building Façade Elements***

Windows on the ground floor shall be rectangular and vertically oriented, and recessed into the exterior wall or window trim, rather than appear as continuous areas of glass flush with the wall plane. Balconies shall be recessed or covered. There shall be trim around openings and windows. Exterior corridors to upper floor room entrances are prohibited for buildings with more than eight dwelling units.

f. ***Store Fronts***

i. ***Design Elements***

The front facade for all retail/commercial uses shall be organized to display merchandise in visible and attractive ways. This requirement shall be met by providing:

- (A) Horizontal and vertical mullions and sashes to subdivide the windows into smaller panes;
- (B) Sturdy and weather resistant storefront base materials;
- (C) One or more angled windows, such as bay windows, or recessed doorways; and

- ii. **Entries**
Entries extending from the main facade, such as arctic entries, are permitted where these areas are designed as an integral part of the structure and do not impede pedestrian movement along the building façade.
- iii. **Glass Windows**
Except for the gC-4 district, commercial buildings shall have a high percentage of glass windows with interior views in the facades, as specified below.
 - (A) Retail/bar/restaurant uses at ground floor: At least 50 percent glass.
 - (B) Retail/commercial use with a sideyard entrance, the portion of the store facing the street: At least 50 percent glass designed as display windows.
 - (C) Ground floor offices facing streets or pedestrian areas: At least 30 percent glass.
 - (D) Ground floor of grocery store facing streets, pedestrian areas or major parking lots: At least 50 percent glass.

3. Roof Form

a. Pitch

Roofs visible from a public way shall be primarily pitched. The pitch for the primary roof structure shall be between 8:12 and 12:12, but may be as shallow as 5:12, as long as the eave overhangs are at least two and one half feet. Segments of the roof may be flatter or steeper slopes, however, to achieve a specific design effect. Wherever a portion of the roof has a shallower pitch than the standard, or if it is flat, provision shall be made to avoid glaciation.

b. Flat Roofs

Flat portions of roofs shall have distinctive cornice features, to create visual interest and provide sufficient overhang to protect walls from the weather. Large visible flat roof forms shall step or be broken by dormers. Design elements may also be used on flat roofs to create the appearance the building has a pitched or shed roof. The canopy sheltering cars at fueling stations may be flat but shall have distinctive cornice detailing. Fueling station canopies shall not be significantly larger and out of proportion to the fueling station building.

c. Overhangs

Roof overhangs shall be sufficient to provide weather protection for building walls. Overhangs on the gable end shall be a minimum of 12 inches. Overhangs on the eave ends shall be a minimum of 24 inches, except the upper eave end of a shed roof is not required to have an overhang. Solariums are exempt from this subsection.

d. Snow and Rain Protection

Roof structures shall be designed to protect doorways, exterior stairs, balconies, vehicle service bays, and garage entrances from snow, ice and rain. Balconies shall be designed to avoid drainage onto other balconies or pedestrian spaces below.

- e. **Roofing Materials**
Roofing materials may be asphaltic shingle, metal, or built-up materials on flat sections. Brightly colored enameled, reflective metal, and wood shakes are prohibited roofing materials.
- f. **Projections from Roofs**
 - i. **Location on Roof**
Chimneys, flues, vents, and antennae shall penetrate the roof near a ridgeline or only where protected from snow movement off the roof. Vent pipes shall be collected into orderly clusters or incorporated into chimney structures.
 - ii. **Cladding Material**
Chimneys and metal flue pipes shall be clad in wood, stone, or stone veneer.

4. Porches, Entrances, Arcades, and Roofed Walkways

A key element of Girdwood mountain style for commercial, community and resort buildings is the use of porches with shed roofs to define entrances. To the maximum extent feasible, all buildings shall utilize porches constructed in accordance with the following standards:

- a. **Landing Height**
Where landings are used, they shall be a minimum of eight inches higher than adjacent walkways or streets.
- b. **Rails**
Porch rails shall be semi-open and/or transparent. Details shall be consistent with other building detailing.
- c. **Entry Size**
Building entrances shall be at least eight feet in width, weather protected, and well lit.
- d. **Arcades and Roofed Walkways**
 - i. **Relationship to Buildings**
Arcades or roofed walkways shall be fully attached to the building front and be of uniform design along the street frontage. Arcades may vary and step along the street frontage with the line and style of the buildings to which they belong. Arcade form, width, scale, materials and colors shall be compatible the adjacent building.
 - ii. **Relationship to Streets**
A landscaped strip for snow storage at least eight feet in width shall be provided parallel to the arcade and shall separate it from the sidewalk edge.
 - iii. **Upper Floor Buildable Area**
After an administrative review and sign-off by the director, the upper story areas above the arcade may be enclosed as part of the building area. The director will review the proposal for conformity with design goals of this chapter and applicable Girdwood area plans.
 - iv. **Clear Space**
Arcades and roofed walkways shall have a minimum of eight feet clear space between arcade columns and the building wall. The arcade of a grocery store shall allow a minimum of 10 feet clear space. The arcade shall be continuous between all entrance/exit doors.

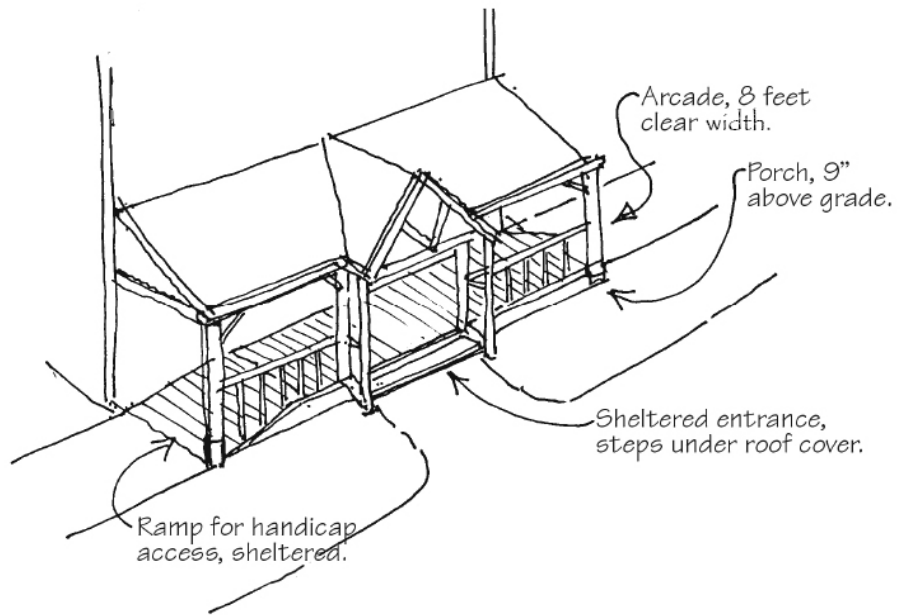

Arcades and Roofed Walkways

- v. *Columns*
Arcade columns shall be in scale with the overall building but shall not obscure ground level storefronts from adjacent pedestrian areas.
- vi. *Roofs*
Arcade and walkway roofs may be flat or sloped to complement other roof forms on the building, but the roof form shall be designed to provide adequate drainage and prevent snow dump, icicle build-up, or rainwater dripping over points of entry to the arcade or walkway. Canvas, metal, or acrylic awnings in lieu of structural covered walkways are not acceptable.
- vii. *Elevation above Grade*
Arcaded or roofed walkways shall be elevated at least eight inches above grade.
- viii. *Pedestrian Scale Lighting*
Arcade and roofed walkway lighting shall be adequate to provide for safety and aesthetic quality. Pedestrian scaled lighting, including but not limited to bollards, ceiling or post-mounted, or attached to the building, shall be required as part of the design of covered walkways. Light sources shall be shielded, recessed, and/or directed so glare is avoided.

5. **Building Materials**

a. **Primary Building Materials**

It is intended for wood and stone to be the primary exterior building materials. Vertical or horizontal patterns, rough or resawn wood, board and batten, and round or square cut logs are permitted. Stone is also permitted. Materials at the base of buildings shall be resistant to damage from snow or water.

b. **Columns, Posts, and Beams**

Primary exterior materials of columns, posts and beams shall consist of heavy timbers, peeled log poles, steel, concrete, or stone cladding, or a combination of these materials.

- c. **Alternative Façade Materials**
On multistory buildings, façade materials may include pre-cast concrete or plaster surfaces, if such surfaces are heavily ribbed, textured, architecturally treated to resemble natural materials, or brush hammered, and are colored to fit the overall building design and mountain setting.
 - d. **Remodels**
The architectural design and the materials used in an addition to an existing structure, or accessory structure, shall be compatible with the architectural style and building materials used in the existing structure, unless an entire facade is to be remodeled in a uniform architectural style.
 - e. **Restricted Materials**
No more than 20 percent of any given building facade may be composed of aluminum, untextured vinyl or plastic siding, T-111 siding, brick or exposed concrete. Stucco, treated or textured CMU, or simulated stone veneer may comprise up to 35 percent of any given building façade. No more than five percent of any given building facade may be painted brick.
 - f. **Prohibited Materials**
The following materials are prohibited:
 - i. Shiny, reflective metal surfaces anywhere on the building;
 - ii. Mirrored or highly reflective glass;
 - iii. Untreated concrete or masonry;
 - iv. Unstained or untreated wood, except for cedar and redwood; all other wood elements shall be treated with oil, stain, or other weathering agent, or painted to resist weathering and discoloration from water;
 - v. Plywood siding without board and batten; and
 - vi. White roof gravels.
6. **Building Colors**
- a. **Principal Colors**
Principal colors on a building shall generally be natural color tones, such as browns, ochre yellows, tans, wood colors, green, rust, barn red and gray. White and cream shades of color are permitted on not more than 35 percent of each facade. Bright, primary colors are permitted on not more than 15 percent of each facade.
 - b. **Trim Colors**
Brighter colors than primary building colors are permitted for trim and highlight details, such as cornices, window frames, handrails, and entrance doors. Neon tubing or an equivalent illumination technique is prohibited as a building/roofline outline feature.
7. **Accessory Elements**
- a. **Parking**
Detached garages, carports, and parking garages shall be designed with architectural elements and materials related to the principal commercial building or buildings, and shall be screened from view from public roads and primary common areas with landscaping and/or berming.

G. Industrial Building Design Standards

Building and roof colors shall be forest shades, such as dark green, dark brown, or dark gray, to blend into Girdwood's forest setting from both the ground and the air.

[RESERVED: Design standards for industrial buildings in Girdwood will be further developed in coordination with the update to the *Girdwood Area Plan* and adopted as an amendment to this section.]

(AO 2012-124(S), 2-26-13; AO 2013-117, 12-3-13)

21.09.090 ZONING MAPS

The following zoning maps are provided:

- A. Girdwood Zoning Districts
- B. Girdwood Zoning Districts (Lower Valley Enlargement)
- C. Single-Family/Two-Family Residential Districts
- D. Multiple-Family Residential Districts
- E. Commercial Districts
- F. Industrial Districts
- G. Resort Districts
- H. Girdwood Airport, GIP, and GIP-p Districts
- I. Girdwood Commercial Recreation Districts 1,2 and 3
- J. Girdwood Development Reserve and Recreation Reserve Districts
- K. Open Space and Girdwood Watershed Districts

(AO 2012-124(S), 2-26-13)